

# Innovative indoor lighting Products

**Guide:**  
Prof. K. Munshi

Final Presentation



**Submitted by:**

Nagsen P. Nandurgekar

07613008

PD-II, IDC, IIT-Bombay



# Design Objective

To design innovative Indoor lighting products for better ambience and power saving...

To provide better lighting considering the requirement as per need.

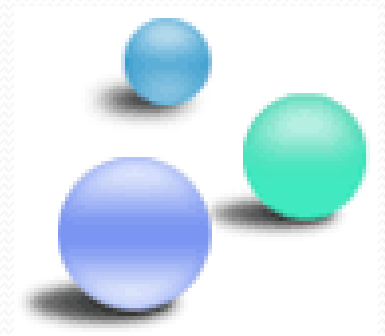

# My approach

- Data collection
  - Internet
  - Magazines
    - Types of lightings
    - Indoor lighting
    - Design elements
    - Colours
    - Relation between colours and emotion
    - Ambience
    - Futuristic lighting
    - Led
- Ideation



# My approach

- Clustering
- Testing some ideas to check their potential
- Detailed study of existing system
- Various possibilities for track light arrangements
- Concepts
- Exploration in different materials



# Types of lighting

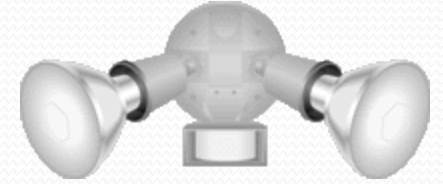

Understand basic lighting terms and principles.....

Types of lighting:

- Fluorescent lighting
- High-intensity discharge lighting
- Incandescent lighting
- Low-pressure sodium lighting
- Outdoor solar lighting

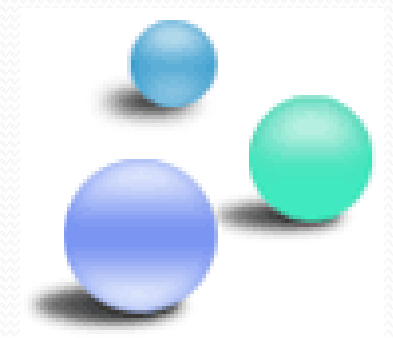

### Lighting Comparison Chart

Lighting Type	Efficacy (lumens/watt)	Lifetime (hours)	Color Rendition Index (CRI)	Color Temperature (K)	Indoors/Outdoors
<b><i>Incandescent</i></b>					
<b><u>Standard "A" bulb</u></b>	10-17	750-2500	98-100 (excellent)	2700-2800 (warm)	Indoors/outdoors
<b><u>Tungsten halogen</u></b>	12-22	2000-4000	98-100 (excellent)	2900-3200 (warm to neutral)	Indoors/outdoors
<b><u>Reflector</u></b>	12-19	2000-3000	98-100 (excellent)	2800 (warm)	Indoors/outdoors
<b><i>Fluorescent</i></b>					
<b><u>Straight tube</u></b>	30-110	7000-24,000	50-90 (fair to good)	2700-6500 (warm to cold)	Indoors/outdoors
<b><u>Compact fluorescent lamp (CFL)</u></b>	50-70	10,000	65-88 (good)	2700-6500 (warm to cold)	Indoors/outdoors
<b><u>Circline</u></b>	40-50	12,000			Indoors
<b><u>High-Intensity Discharge</u></b>					
<b><u>Mercury vapor</u></b>	25-60	16,000-24,000	50 (poor to fair)	3200-7000 (warm to cold)	Outdoors
<b><u>Metal halide</u></b>	70-115	5000-20,000	70 (fair)	3700 (cold)	Indoors/outdoors
<b><u>High-pressure sodium</u></b>	50-140	16,000-24,000	25 (poor)	2100 (warm)	Outdoors
<b><u>Low-Pressure Sodium</u></b>	60-150	12,000-18,000	-44 (very poor)		Outdoors

# Fluorescent lighting

25%–35% of the energy used by incandescent lamps –same amount of illumination

last about 10 times longer (7,000–24,000 hours)

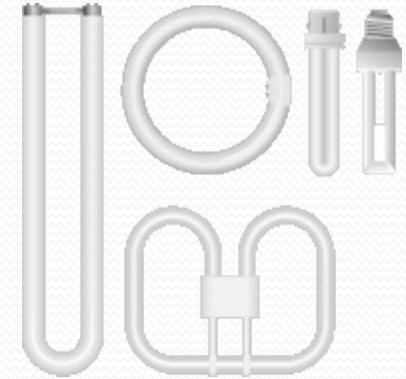

Types of fluorescent lights:

- Compact fluorescent lamps (CFLs)
- Fluorescent tube and circline lamps

Fluorescent Lighting Type	Efficacy (lumens/watt)	Lifetime (hours)	Color Rendition Index (CRI)	Color Temperature (K)	Indoors/Outdoors
<b><u>Straight tube</u></b>	30–110	7000–24,000	50–90 (fair to good)	2700–6500 (warm to cold)	Indoors/outdoors
<b><u>Compact fluorescent lamp (CFL)</u></b>	50–70	10,000	65–88 (good)	2700–6500 (warm to cold)	Indoors/outdoors
<b><u>Circline</u></b>	40–50	12,000			Indoors

# Compact Fluorescent Lamps

- Compact fluorescent lamps (CFLs) combine the energy efficiency of fluorescent lighting with the convenience and popularity of incandescent fixtures.

They consist of two parts: a gas-filled tube, and a magnetic or electronic ballast. The gas in the tube glows with ultraviolet light when electricity from the ballast flows through it. This in turn excites a white phosphor coating on the inside of the tube, which emits visible light throughout the surface of the tube.

- CFLs are designed to operate within a specific temperature range.
- CFLs are most cost effective and efficient in areas where lights are on for long periods of time.



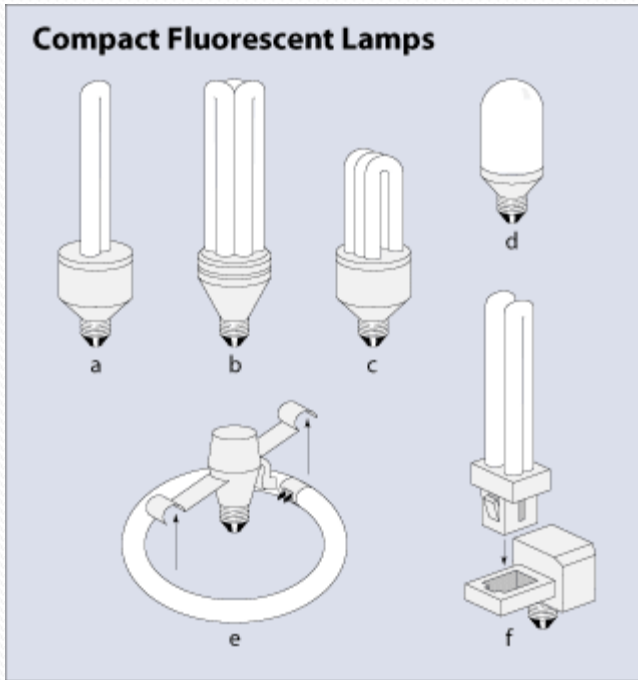

Compact fluorescent lamps (CFLs) come in a variety of sizes and shapes including (a) twin-tube integral, (b and c) triple-tube integral, (d) integral model with casing that reduces glare, (e) modular circline and ballast, and (f) modular quad-tube and ballast. CFLs can be installed in regular incandescent fixtures, and they consume less than one-third as much electricity as incandescent lamps do.

**Cheaper To Run, More Expensive To Install -**  
They are cheap to operate as they emit about four times as much light per unit of electricity as incandescent lights do





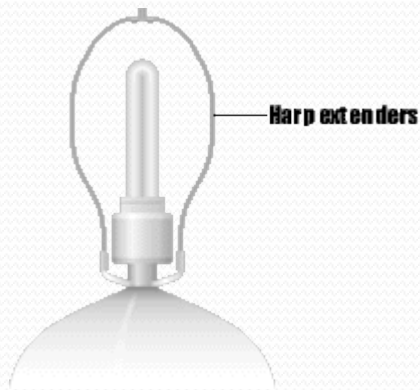

**How They Work** -Fluorescent lights work by placing an anode and a cathode at opposite ends of a glass tube

**Industrial Tubes** -These tubes include the ubiquitous "cool white" and "warm white" usually used in home and industrial lighting applications

**Industrial Tubes** -These tubes are tuned to produce the brightest possible illumination for the least amount of electricity

**Full Spectrum** -Full spectrum tubes imitate, as closely as possible, natural sunlight by emitting light in every spectral range



Bare Products		Covered Products			Reflector Products
Mini-Spiral or Twist	Tube or Universal	Incandescent/ A-line	Globe G25, G30, G40	Candelabra, Post or Bullet Shape	Indoor and Outdoor R20, R30, R40, PAR38
					



**Spiral Lamps:** The spiral lamp is the most popular model of compact fluorescent bulbs. Spiral bulbs are particularly suitable to table floor lamps, ceiling fixtures, wall sconces, and outdoor covered lamps.

**Tube Lamps:** This type of lamp is particularly fit for table floor and task lights, pendant fixtures, ceiling fixtures and outdoor covered fixtures.

**The incandescent A-line fluorescent** is particularly suitable for table/floor lamps, pendant fixtures, ceiling fans and outdoor covered fixtures.

**Globe fluorescents** are suitable for pendant fixtures and ceiling fans.

**Candelabra, Post or Bullet shape fluorescents** are suitable for wall sconces and outdoor covered lamps.

**Indoor reflector fluorescents** are suitable for recessed cans and track lighting.

**Outdoor reflector fluorescents** are particularly suitable for outdoor exposed fixtures. Be careful with fluorescent for outdoors: some do not operate well at cooler temperatures (below 40°F), though there are “weatherproof” models and Energy Star models qualified to low outdoor temperatures.

## Fluorescent Tube and Circline Lamps

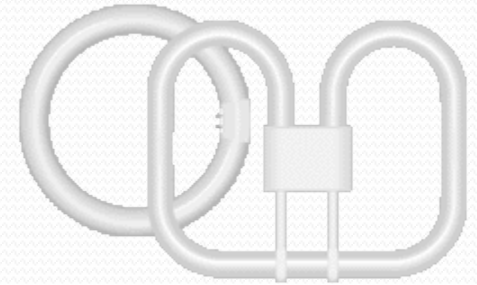

The traditional tube-type fluorescent lamps are usually identified as T12 or T8 (12/8 or 8/8 of an inch tube diameter, respectively). They are installed in a dedicated fixture with a built-in ballast. The two most common types are 40-watt, 4-foot (1.2-meter) lamps, and 75-watt, 8-foot (2.4-meter) lamps.

Tubular fluorescent fixtures and lamps are preferred for ambient lighting in large indoor areas. In these areas, their low brightness creates less direct glare than incandescent bulbs.

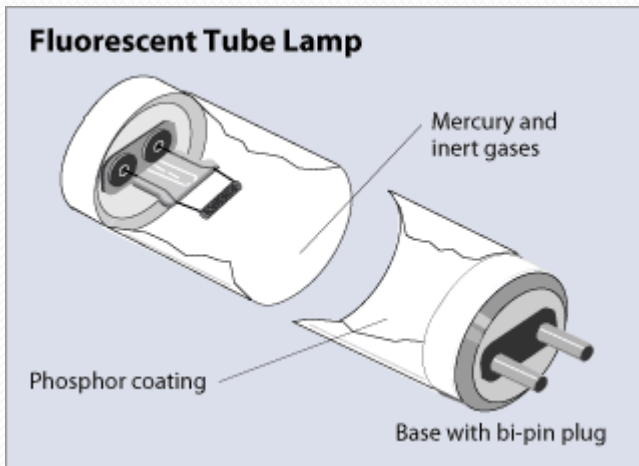

In fluorescent tubes, a very small amount of mercury mixes with inert gases to conduct the electrical current. This allows the phosphor coating on the glass tube to emit light.

# High-Intensity Discharge Lighting

- High-intensity discharge (HID) lamps provide the highest efficacy and longest service life of any lighting type. They can save 75<sup>0</sup>%–90<sup>0</sup>% of lighting energy when they replace incandescent lamps.
- Because of the intense light they produce at a high efficacy, HID lamps are commonly used for outdoor lighting and in large indoor arenas

## High-Intensity Discharge (HID) Lamp

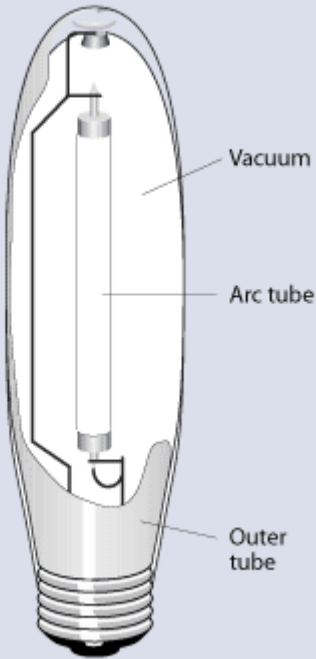

In a high-intensity discharge lamp, electricity arcs between two electrodes, creating an intensely bright light. Mercury, sodium, or metal halide gases act as the conductor.

### Types:

- Mercury vapor lamps
- Metal halide lamps
- High-pressure sodium lamps.

High-Intensity Discharge Lighting Type	Efficacy (lumens/watt)	Lifetime (hours)	Color Rendition Index (CRI)	Color Temperature (K)	Indoors/Outdoors
<u>Mercury vapor</u>	25-60	16,000-24,000	50 (poor to fair)	3200-7000 (warm to cold)	Outdoors
<u>Metal halide</u>	70-115	5000-20,000	70 (fair)	3700 (cold)	Indoors/outdoors
<u>High-pressure sodium</u>	50-140	16,000-24,000	25 (poor)	2100 (warm)	Outdoors

# Incandescent Lighting

- Incandescent lighting is the most common type of lighting used in homes. It has traditionally delivered about 85% of household illumination.
- They light up instantly, providing a warm light and excellent color rendition. You can also dim them. However, incandescent lamps have a low efficacy compared to other lighting options (10–17 lumens per watt) and a short average operating life (750–2500 hours).
- Incandescent lamps are the least expensive to buy, but because of their relative inefficiency and short life spans, they usually are more expensive to operate.

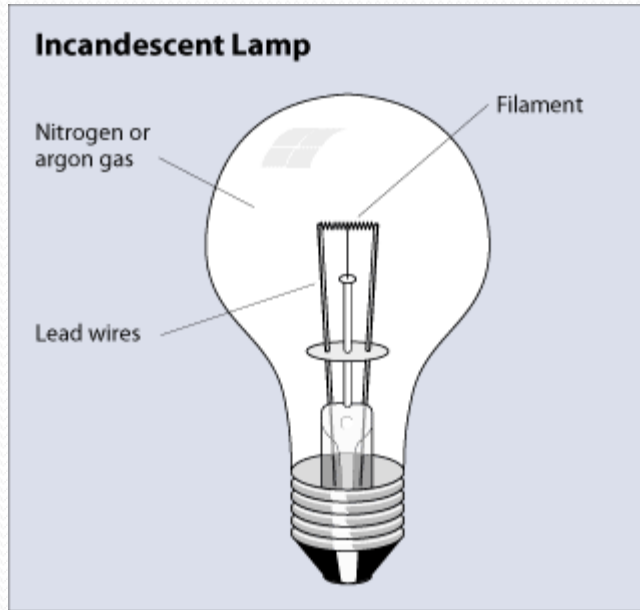

The incandescent lamp is the oldest and most common type of lamp. Light is emitted when electricity flows through—and heats—a tungsten filament.

**Cheap, low quality light** -Incandescent lights are the ubiquitous screw-in bulbs

**Halogen bulbs** -A variation of the incandescent bulb is the halogen bulb

**Output spectra is biased towards the red** - The output spectrum of incandescent light, halogen or regular, is biased heavily toward the red. Non halogen bulbs have a colour temperature of 2700K

**Efficiency** -The two great disadvantages to incandescent lights are their inefficiency - you don't get a lot of light compared with how much energy you put apply

**Longevity** -Incandescent bulbs have a lifespan of about 1000 hours. Halogen bulbs have a life of about 2000 hours



## Types:

- Standard incandescent lamps
- Tungsten halogen lamps
- Reflector lamps

<b>Incandescent Lighting Type</b>	<b>Efficacy (lumens/watt)</b>	<b>Lifetime (hours)</b>	<b>Color Rendition Index (CRI)</b>	<b>Color Temperature (K)</b>	<b>Indoors/Outdoors</b>
<b><u>Standard "A" bulb</u></b>	10-17	750-2500	98-100 (excellent)	2700-2800 (warm)	Indoors/outdoors
<b><u>Tungsten halogen</u></b>	12-22	2000-4000	98-100 (excellent)	2900-3200 (warm to neutral)	Indoors/outdoors
<b><u>Reflector</u></b>	12-19	2000-3000	98-100 (excellent)	2800 (warm)	Indoors/outdoors

- **Standard Incandescent Lamps**

- Known as the screw-in "A"-type light bulb
- These standard incandescent lamps produce light from a tiny coil of tungsten wire that glows when it is heated by an electrical current.
- Larger wattage incandescent bulbs have a higher efficacy than smaller wattage bulbs.

- **Tungsten Halogen Lamps**

- Tungsten halogen lamps—a type of incandescent lighting—achieve better energy efficiency than standard, incandescent A-type light bulbs.
- Tungsten halogen lamps have a gas filling and an inner coating that reflect heat. Together, the filling and coating recycle heat to keep the filament hot with less electricity.
- These lamps provide excellent color rendition. They also are considerably more expensive to buy than standard incandescent lamps, but are less expensive to operate because of their higher efficacy.

- **Reflector Lamps**

- Reflector lamps (Type R)—a type of incandescent lighting—spread and direct light over specific areas. They are used mainly for floodlighting, spotlighting, and downlighting.
- There are two types of reflector lamps: parabolic aluminized and ellipsoidal.
- Ellipsoidal reflectors are twice as energy efficient as parabolic reflectors for recessed fixtures.

**Figure 1. Percent of Households Using Incandescent, Fluorescent, and Compact Fluorescent Lights, 1993**

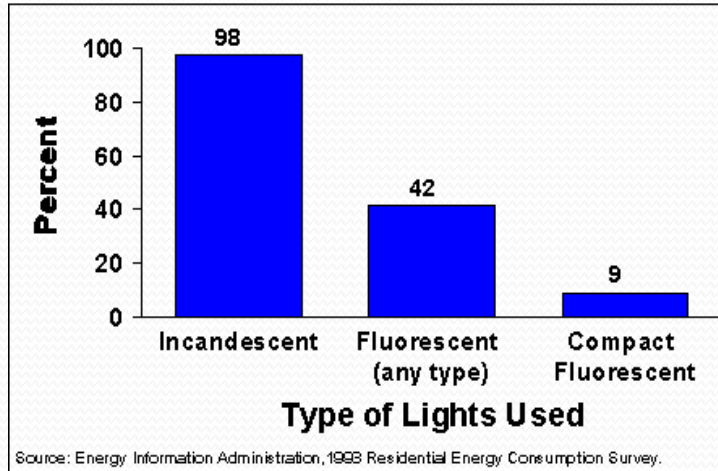

**Figure 2. Percent of Lit Commercial Floorspace Lit by Incandescent, Fluorescent and Compact Fluorescent Lights, 1995**

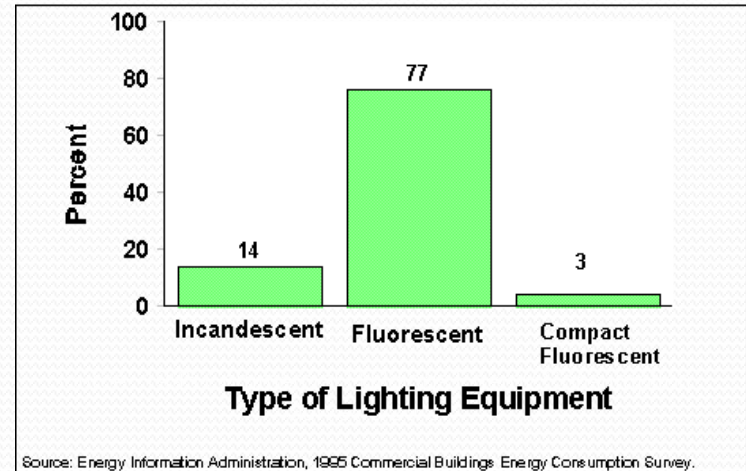

**Figure 3. Potential Energy Savings from Replacement of Incandescent Lights with Compact Fluorescent Lights, 1993**

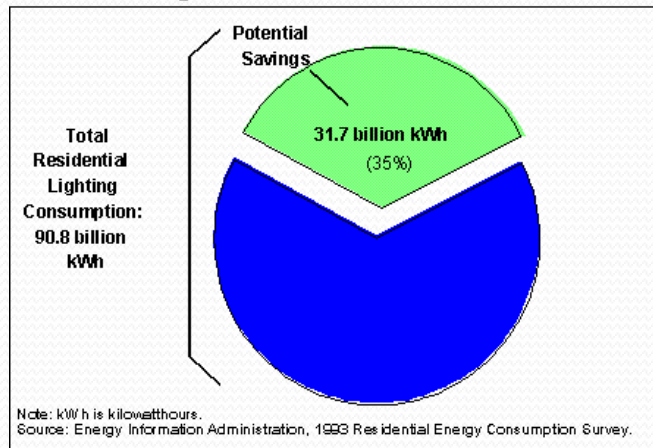

# Low-Pressure Sodium Lighting

- Low-pressure sodium lamps provide the most energy-efficient outdoor lighting compared to high-intensity discharge lighting, but they have very poor color rendition. Typical applications include highway and security lighting, where color isn't important.
- low-pressure sodium lamps require up to ten minutes to start and have to cool before they can restart
- most suitable for applications where they stay on for hours at a time. They are not suitable for use with motion detectors.

# Outdoor Solar Lighting

- Outdoor solar lights are easy to install and virtually maintenance free. Best of all, they provide free electricity.
- Outdoor solar lighting systems use solar cells, which convert sunlight into electricity
- Manufacturers most commonly use nickel cadmium, sealed lead acid, and lead acid batteries.

# LIGHTING SERVICES



## Interior

Good interior design is the application of the best or most appropriate equipment in an economical but effective manner. Commercial & Industrial lighting schemes carried out for the following applications:-

- Offices
- Office Atria
- Retail Outlets
- Schools
- Hospitals
- Sports Halls
- Swimming Pools
- Manufacturing Plants
- Warehouses
- Multi-Storey Car Parks





## Exterior

The key objectives to consider when looking at an exterior design are safety, performance and appearance. Building & area lighting schemes carried out for various applications including:-

- Architectural
- Security
- Amenity
- Car Parks
- Sports Facilities
- Street Lighting



## Emergency

An emergency lighting system is designed to enable the building to meet fire safety legislation in a way that is visually acceptable and meets the end user's needs for operation and maintenance.

All exit route, open area, and directional signage designs carried out to the latest BS standards. Planning for self-diagnostic monitoring systems is also available (easichck / self test etc).





# Indoor lightings

- Nothing affects our lifestyle quite the way indoor lighting does. When you're entertaining, make your guests feel more welcome by choosing the right Indoor light.



# Design elements

## Indoor lighting Accessories

- **About Chandeliers**

Chandeliers enhance the beauty of a dining area and when the light is dimmed, a soft, glowing atmosphere similar to candlelight is created. Don't forget your choice of Chandelier Shades and Chandelier glass to personalize your selection.

Chandeliers add sparkle and style to your dining room while giving you the general lighting you need for dining and entertaining. Chandeliers are also used in bedrooms, foyers, or over a living room grouping or a grand piano



## ● **Chandelier Lighting**

- Chandelier Lighting helps create a mood or an effect, it aids in a task, and also helps express your personal style. Whether casual, contemporary, eclectic, modern, transitional, or simply traditional, Chandeliers are the perfect way to achieve your desired fashion or functional needs

### **Traditional Chandeliers**

Home Builders, Architects, and Interior Designers today. Single Tier Chandeliers, Multi Tier Chandelier Fixtures, Bound Glass Chandeliers & Energy Efficient Chandelier Lighting will enhance the beauty of any room.

### **Contemporary Chandelier Shopping**

to reflect your style, application, and budget



- **About Wall Sconces**

With a decorative wall sconces or torchiers, lighting can transform a functional room or hallway into a cozy retreat or dramatic passageway.





- **Wall Sconces**

- Bathroom Lighting offers shadow-free lighting for shaving, grooming, and applying makeup in your, powder room, spa, or dressing area.

### **Wall Lighting**

to achieve your desired fashion or functional needs

### **Sconces**

enhance the beauty of any bathe area..



- **About Mini Pendants**

Mini Pendants - as graceful as a teardrop. Our mini-pendant lighting provide interest And warmth to any setting in a less formal style





- **Mini Pendants**

- Mini Pendant Lighting can provide both task and general lighting. Equipped with shades or globes to avoid glare, they are suspended from the ceiling over dinette tables, game tables, kitchen counters, or other work areas

### **Mini Pendant Lighting**

unique glass designs and shade materials that make these products some of the most attractive and desired styles available today in mini pendant lights.

### **Ambiance Mini Pendants**

to give better ambience.

### **Low Voltage Mini Pendants**

available in many sizes for indoor areas with incandescent, halogen, Xenon, and energy saving fluorescent light sources.

### **Line Voltage Mini Pendants**

Select plated and hand painted finishes such as polished brass pendants, antique silver pendants and a variety of other finishes.



- **About Under Cabinet Lights**

- Under cabinet lighting brings an unobstructed light to work surfaces as opposed to light coming from behind, creating shadows. Under cabinet lighting is a great way to add distinction and style to any kitchen or work area.



## • **Under Cabinet Lighting**

- styles and finishes that compliment the most popular faucet styles, making the selection even easier in incandescent or energy saving Cabinet lights.

### **Task Lights**

of plated as polished brass wall and bath lights, antique silver wall and bath lights, variety of other finishes.



- **About Track Lights**

- Track Lighting was never so easy with the patented **Ambiance®** Track Lighting system. Offering flexible and easy to install products for the most effective use of track lighting in any room.



- **Track Lights**

- Choose from a pre-assembled track lighting kits, or build your own track light package, or choose new track heads or track lights to add to or reconfigure an existing system

### **Track Lighting Kits**

feature hundreds of track lighting styles making us the selection of Home Builders, Architects, Retail Merchandising Professionals, and Interior Designers today

### **Track Lighting Components**

of track light finishes such as white, black, polished brass, chrome, eurotech, and more



- **About Fluorescent Lights**

- The look of fluorescent lighting and energy efficient lighting has evolved into decorative fixtures, sconces and outdoor fluorescent lighting that reduce operating costs.



## • Fluorescent Lighting

- Fluorescent Lighting, work to reduce your energy bills and significantly and help to protect our environment

### Fluorescent Lights

Energy saving fluorescent products are available in chandeliers, pendants, wall sconces, vanity bath lights, ceiling mounted fixtures, recessed cans, outdoor lanterns, and more using compact fluorescent light bulbs and circle line lamps.



- **About Bathroom Lighting**

- Vanity and bathroom lighting dress up a bathroom, illuminate a wall mirror, and provide endless possibilities for vanities and dressing rooms. Our bathroom vanity lighting warms an otherwise cold room, enhances the beauty of vanity hardware.





## • About Pendants

- As graceful as a teardrop, our pendant lighting provides interest and warmth to any setting in a less formal style.



- **About Ceiling Lights**

- Close to ceiling fixtures add the finishing touch to a well-decorated environment providing a decorative, functional illumination to any location.



- **About Foyer Lights**

- Elegant foyer lights, from grand two-story foyers to a quaint country entryway, Sea Gull Lighting provides the foyer lighting fixture to illuminate and warm the welcome.



- **About Transitions Lighting**

- Now Ambiance Transitions joins the highly specified Ambiance Lighting Systems family of products. Ambiance Transitions, the line voltage lighting system that offers splashes of color, style, and light on 120v rail and decorative pendant choices.

Ambiance Transitions line voltage rail systems offer general, task and accent lighting with design and installation flexibility for any lighting challenge.



## • Configuration of Transitions Lighting Systems

FOR A TRULY CUSTOMIZED SYSTEM  
SELECT FROM THE FIVE BASIC COMPONENTS:

1. Luminaires
2. Lamps
3. Rail
4. Power Feed
5. Mounting and Other Accessories

BE CREATIVE!!

Add any applicable accessories,  
e.g., pendants, connectors, etc.





# Modern Lighting

You recognize how bad you look in the aircraft bathroom under the cruel fluorescent lights? You're every imperfection, seam, or stray hair highlighted.

That is how bad your home looks with no modern lighting.  
Now that you have invested in some elegant furnishings and thoughtfully planned your living space, you will need contemporary lighting to add to it all



# Traditional Lighting

With an eye towards aspect and approach, these traditionally fashioned hanging light fittings from LAMPS PLUS are a magnificent way to light your preferred living space. From brass candlestick to traditional shaded chandeliers, these furnishings will bring a new stage of detail and complexity to your residence.





# Designer Lighting

- There are three types of lighting, such as environment, assignment, and ornamental. Each one serves a specific and necessary purpose. Background illumination is made-up to compensate for natural light in daytime. At night, this light needs to be detached evenly in a room. Task lighting throws influential and focused light on an area. Decorative lighting is fashionable and a bright light is thrown on an object for highlighting it.

Some aspects of imaginative lighting include focusing a dim light across fences and walls, highlighting water features with a precise group of lights or enlightening trees when lights are placed below and behind them.



## Bathroom Lighting

One way to achieve more than a few lighting tasks at once with bathroom lighting is to rely upon dimmer switches that permit you to alter the light from faint to strong with the turn of a dial or the flick of a switch.

it is most likely that the lighting in your bathroom will be best accomplished by using more than one kind of lighting



# Low Voltage Lighting

Low Voltage Lighting produces the same quantity of light but uses less electrical energy. They can offer two and a half times as much light as produced by the normal line voltage radiant lamps. In simple words, a 50 watt low voltage lamp could possibly be more than enough to produce as much light as offered by a 125 watt line voltage lamp. So there defiantly worth considering if you're looking for new lights.



- **Cornice lighting** – a long light source along a wall near the ceiling; light is directed down
- **Cove lighting** – a long light source along a wall near the ceiling; light is directed up



Cornice lighting

# Colours

## Science of Colours:

- We all know that all colors are made up of three primary colors - red, blue and green - in various combinations. Secondary colors are made up of mixing of these primary colors such as cyan; yellow and purple while tertiary colors are made up of mixing the secondary colors to the primary colors such as reddish orange and yellowish green.
- **Actual meaning of the words used above:**
- Hue means Color such as red color or red hue,
- Tint means the pure color mixed with white such as tints of red means red mixed with white color to produce different kind of reds and pinks,
- Tone of a color means that the pure color is mixed with grey,
- Value of a color means the lightness and darkness of a shade achieved by the sheer or deeper application of the color,
- Key colors are the dominant colors that we have chosen for room or home décor, while Shade of a color means that the pure color is mixed with black.
- Color can make quite a lot of difference to the size and proportion of the room

## Choosing colour schemes:

Color scheme helps your to determine the harmony between colors in home décor. A color wheel can be quite useful while deciding a color scheme for your home as it helps you to compare complimentary colors.

- **Monochromatic color scheme** uses only one color throughout. Variety is introduced by using various tints, tones, values and shades of that key color and different textures.
- **Complimentary color scheme** uses two colors placed opposite to each other on the color wheel, their tints, tones, shades and values such as yellow and violet. This scheme is quite bold and lend a dramatic touch to the home décor.
- **Triadic color schemes** use three hues placed consecutively or at equal distances from each other such as red, yellow and blue, their tints, tones, shades and values



- Colours are good means to convey emotions. Although there is a psychology of colour and some of them have universal emotional effects, in most cases their meanings are culture dependent.
- The emotions associated to some colours have a strong cultural component.
- Colours are typically divided into warm (yellows, reds, oranges) and cool ones (blues, greens and violets) due to primitive and probably universal associations to the sun and fire for the former ones and to water and vegetation the latter ones.

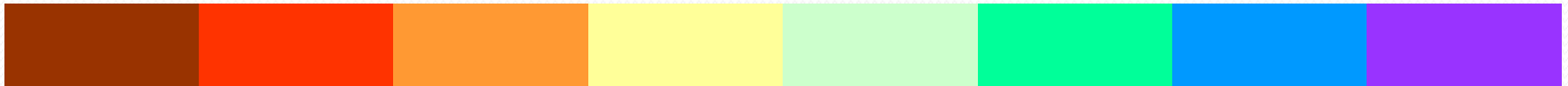

**Warm and cool colours.** In this example the colours of the left half are considered warm ones and those of the right half are considered to be cool.



- **Red:** danger, excitement, fire, passion, blood, fight or flight, some sexual connotation.
- **Purple:** Wealth, royalty, sophistication, intelligence.
- **Blue:** Quietness, serenity, truth, dignity, constancy, reliability, power.
- **Black:** Sophistication, elegance, power, rebellion.
- **White:** Purity, cleanness, luminosity, vacuum.
- **Yellow:** Warmth, the sun for many cultures, brightness, joy if little saturated.
- **Green:** Nature, fresh, vegetation, health, green/blues are the favorites of consumers





## Definition of colour emotion..

- Colour emotion can be defined, in a simple fashion, as the relationships between colour and the viewer's psychological response.
- A more complex definition is perhaps the relationship between colour stimuli and *psychological responses in terms of both semantic associations and emotion words*, considering the configurations and the context in a visual experience.



## Colour Emotion vs. Colour Semantics

- The term "colour emotion" has been incorrectly used during the past few years for studies into the relationships between colours and semantic words such as "warm" and "active".
- *Colour emotion* concerns human emotions evoked when seeing specific colours. "Emotion terms" are those describing human emotions such as *excitement, happiness* and *anxiety*.
- *Colour semantics* concerns meanings or semantic associations of colours. Studies of colour semantics normally use word pairs to describe specific characteristics related to colours, such as *warm-cool, heavy-light* and *active-passive*.

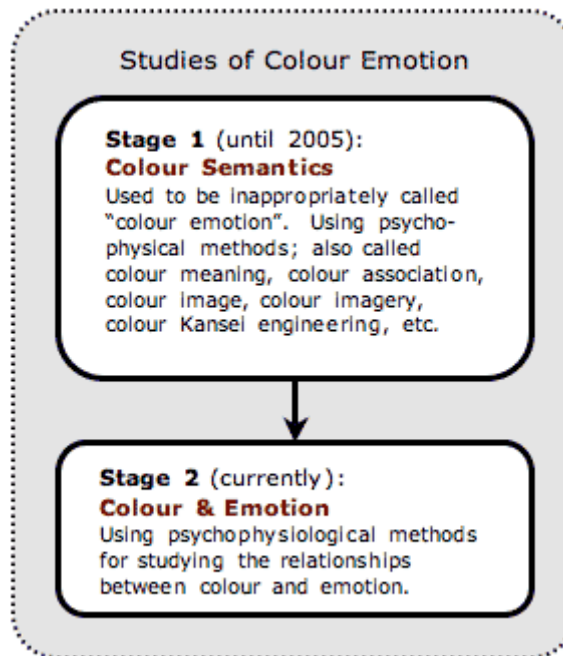



**Design Awards - Chaplo shows your interiors in their best light:**

©2008 Paul Chaplo, MFA. Design Award Photography Texas



**Franchise Restaurant Interior Photography:** Restaurant: Pizza Inn Prototype Interior, Plano, Texas. 2008 Paul Chaplo, MFA.



**Residential Dallas/Fort Worth Interior**  
Photographer: Paul Chaplo.



**Second Take: Residential Dallas/Fort Worth Interior**



**RESIDENTIAL INTERIOR POOL ENCLOSURE:** This pool enclosure was photographed in Las Vegas, Nevada for a national advertising campaign.



**The Eisemann Center: Performing Arts Center** during the premier of the Stephen Knapp light painting. Interior Civic Art Center. Municipal Art Center, Richardson, Texas.



**Office Interior Digital Photography** by Paul Chaplo: New Office. This was an architectural commission and the image was used for marketing, presentations, trade shows



**EDUCATIONAL - COMMUNITY FINE - PERFORMING ARTS CENTER AUDITORIUM** This image was shot for a trade/show convention in Austin, TX.



**PERFORMING ARTS AUDITORIUM:**



Los Angeles, CA



trendy spots lining the avenues of Bucktown and Wicker Park.





Designed by the internationally-renowned firm of VOA Associates





The Hbo Store in New York, Designed by Gensler. Feature Factory in Toronto Facilitated Its Construction Through the Management of Digital Fabrication.



To Ensure An Error-Free Installation, the 250-Foot-Long Wall Was Constructed Using a Template Affixed to the Rough Concrete Floor

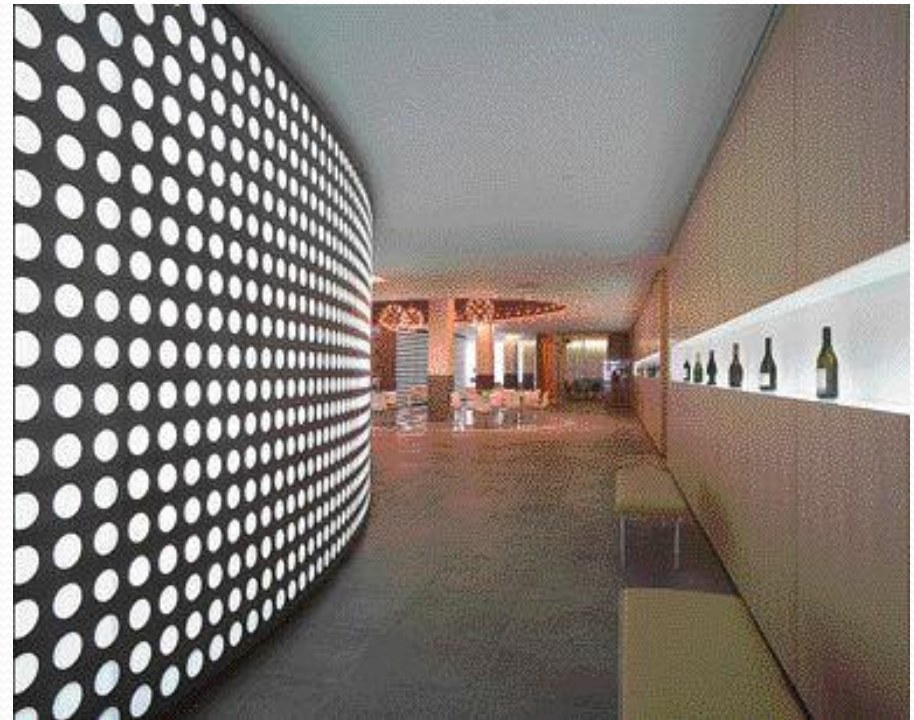

The Completed Office Space Uses a Variety of Interior Lighting Strategies to Define Its Various Programmatic Requirements.

# Ambience

## About Ambience Lighting

Ambience low voltage lighting is easy to install, place light anywhere you need or want to create a dramatic effect with linear, surface mount, And recessed options.

Ambience Low Voltage Lighting Systems are a high quality, exceptionally broad range of products specified in virtually any architectural, commercial and lighting application. This patented system is categorized into three categories.



## About Linear Lighting

- Ambiance low voltage lighting is easy to install, place light anywhere you need or want to create a dramatic effect with linear, surface mount, And recessed options.



## Configuration of Ambiance® Low Voltage Linear Lighting Systems

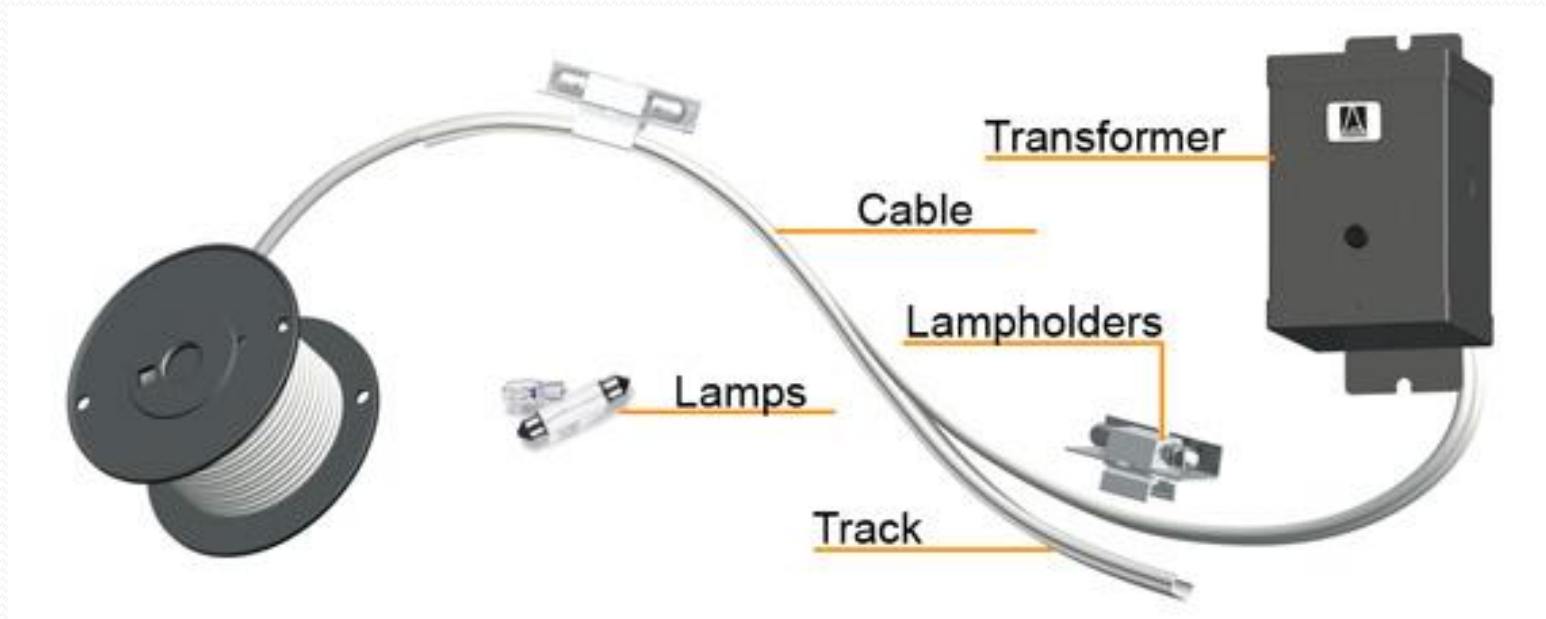

## About Landscape Lighting

- Ambiance low voltage lighting is easy to install, place light anywhere you need or want to create a dramatic effect with linear, surface mount, And recessed options.



# Configuration of Ambiance<sup>®</sup> Landscape Lighting Systems





## About Transitions Lighting

- Ambiance Transitions joins the highly specified Ambiance Lighting Systems family of products. Ambiance Transitions, the line voltage lighting system that offers splashes of color, style, and light on 120v rail and decorative pendant choices.

Ambiance Transitions line voltage rail systems offer general, task and accent lighting with design and installation flexibility for any lighting challenge.



# Configuration of Transitions Lighting Systems

FOR A TRULY CUSTOMIZED SYSTEM  
SELECT FROM THE FIVE BASIC COMPONENTS:

1. Luminaires
2. Lamps
3. Rail
4. Power Feed
5. Mounting and Other Accessories

BE CREATIVE!!  
Add any applicable accessories,  
e.g., pendants, connectors, etc.



## About Rail Lighting

- Ambiance low voltage lighting is easy to install, place light anywhere you need or want to create a dramatic effect with linear, surface mount, And recessed options.



# Configuration of **Ambiance<sup>®</sup>** Low Voltage Rail Lighting Systems

1. Rail
2. Power Feed
3. Mounting and Other Accessories
4. Luminaires
5. Lamps
6. Transformers



## About Disk Lighting

- Ambiance low voltage lighting is easy to install, place light anywhere you need or want to create a dramatic effect with linear, surface mount, And recessed options.



# Configuration of Ambiance<sup>®</sup> Disc Lighting Systems

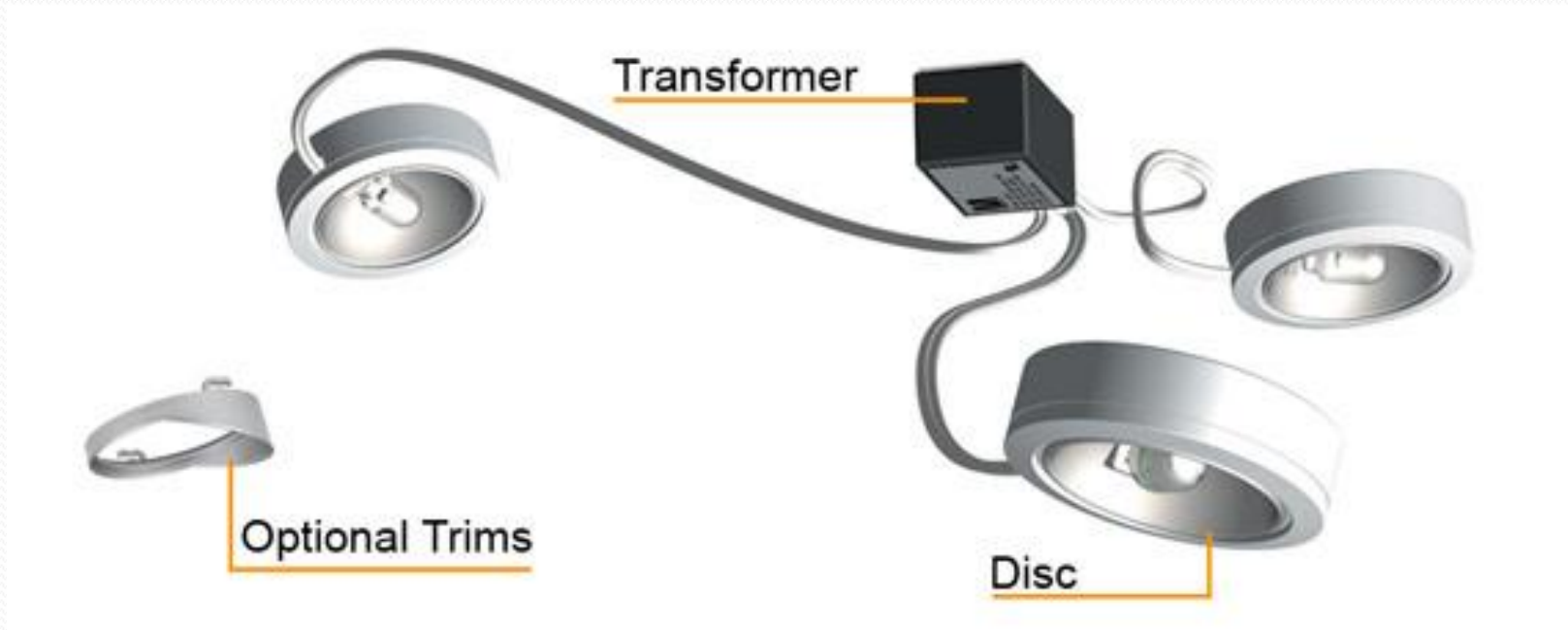

## About Low Voltage Recessed

- Ambiance low voltage lighting is easy to install, place light anywhere you need or want to create a dramatic effect with linear, surface mount, And recessed options.



# Configuration of Ambiance<sup>®</sup> Recessed Lighting Systems

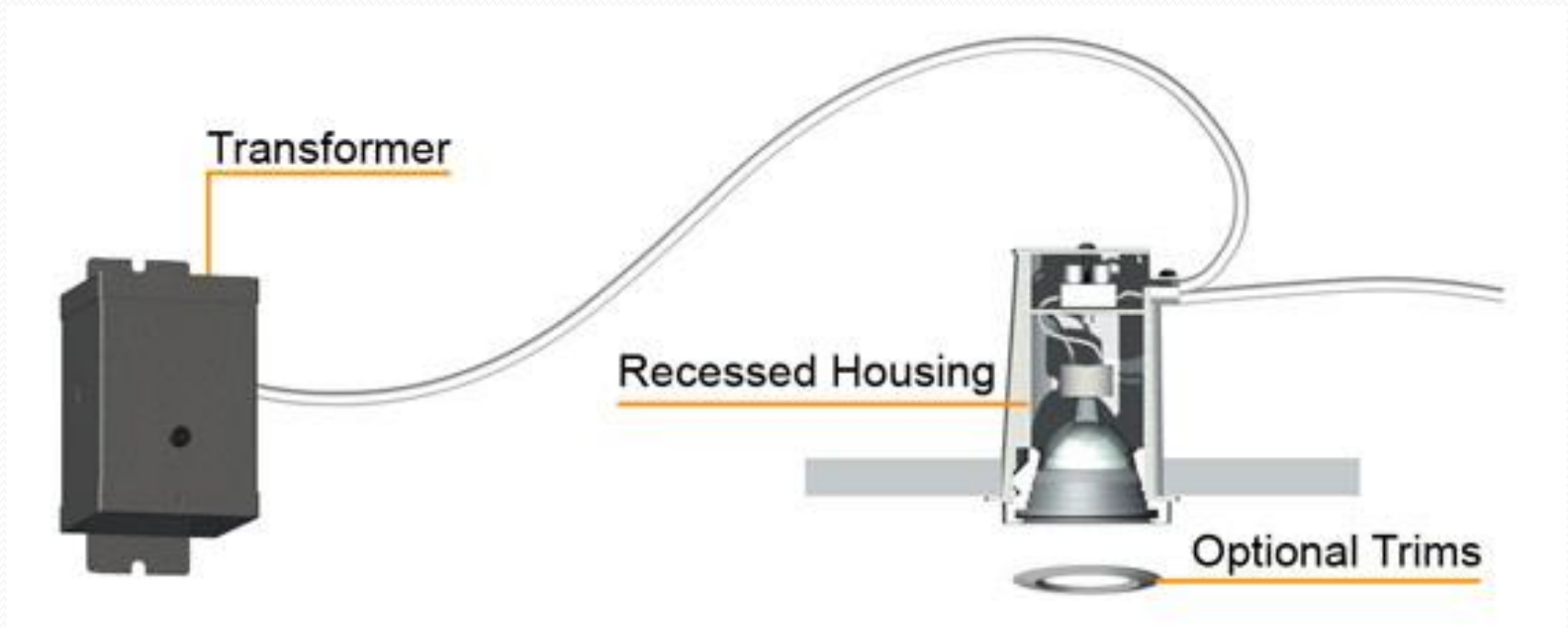



Pictures of Ambient lighting.....







# Lighting as per need

## Architectural lighting

- Architectural lighting enables the designer/client to put their unique style into the form of the luminaire, as opposed to just having function of the lighting. This encompasses such diversity as colour as well as overall aesthetically pleasing design.









- Various types...

**DIVA:**

'DIVA' combines our injection, extruding, sheet steel, and special finishes with our design expertise together with the practicalities of multi lamp switching, dimming and infinite possible colour combinations to give this luminaire its own style and personality

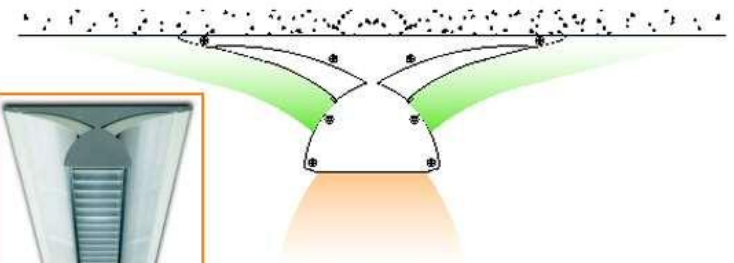
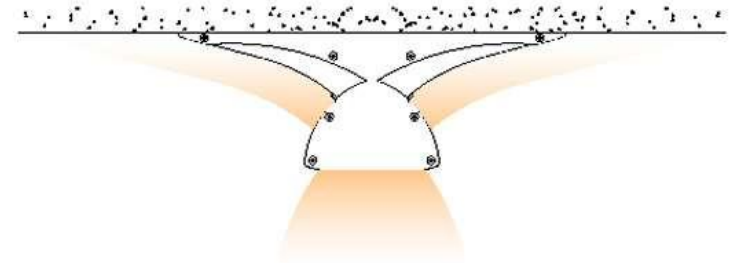



## Bubble

- A Suspended sphere of light, the bubble is a neat interpretation of the ancient medieval candelabra. This luminaire is also available as a wall mounted version to portray the dynamics of an interior. Designed to be installed in Architectural projects, this luminaire is characterised by its attractive styling and is available in three sizes that utilize the latest in energy efficient lamps with the option for variable colour lighting. The BUBBLE integrates unobtrusively in diverse applications such as wide public areas, Hotel halls and reception desks, exhibition areas, conference rooms and show rooms.



## Seven

- A flexible design concept to be stylish and practical allowing the designer to exercise individual flair in lighting effects. This luminaire has up to three optics with the flexibility of ceiling or wall mounting and an adjustable micro-mirror arch for a customised lighting effect. This allows for the lighting of the wall, ceiling and work space simultaneously within the area.



## Dea

- Our 'DEA' range of luminaries were our first family of luminaries to deviate from the traditional louvered fitting, so allowing more design flexibility within the interior whilst utilizing the light available from the given lamps to diffuse and bounce the light all over the interior to creating a brighter and lighter workplace. These are available in a myriad of designs utilizing a range of lamps and can be recessed, surface, wall and suspended mountings.

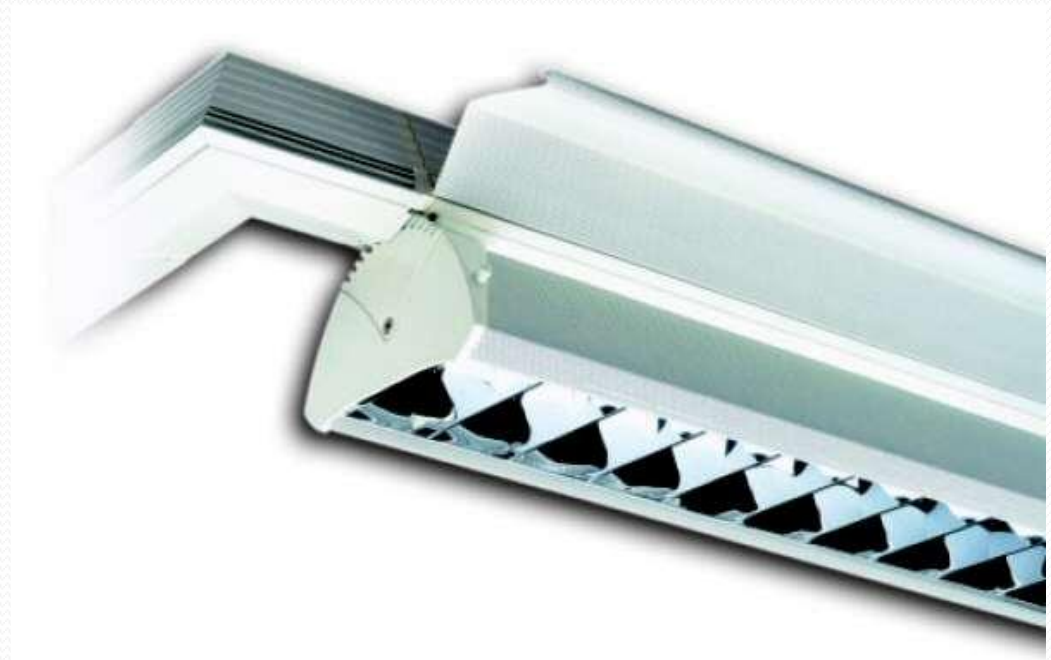

## MIG51

- The Dynamic Character of this range is its ability to change shape in the space and render the space according to different angles of the luminaire components.

This range is available as suspended or wall mounted. The flexible optics are able to meet the demands of open spaces and office/VDT areas. With its upward and downward lighting ability this is a stylish solution for the modern work place.



## Tail

- Designed for minimalism , multifunctionality and colour, these are the essentials of modern architecture that are reflected in the TAIL range of products. These fittings can be Suspended, Surface, Wall mounted or Free standing, and are also available as a continuous system. With a variety of optics and screens, this range is very versatile. There is also the option to incorporate coloured LED on each side of the luminaire for added visual effect.



## QSD

- The 'QSD' range of luminaires create their own unique style within the interior, whilst complimenting the square ceiling tiles traditionally fitted in modern buildings. These downlighters are available in a variety of lamp configurations and colours plus any number of feature glass designs.



## Tek

- This stylish wall mounted system was conceived mainly to combine lighting and beauty with technical excellence within corridors. 'TEK' can be continually mounted with all wiring concealed, or stand alone. We have the possibility to project light upwards and downwards, plus the usual variety of lamp sources and integral emergency options. With the growing trend to 'colour code' corridors for easy recognition (in hospitals for instance) this lighting system provides the perfect application, with the added benefit of having illuminated signage available.

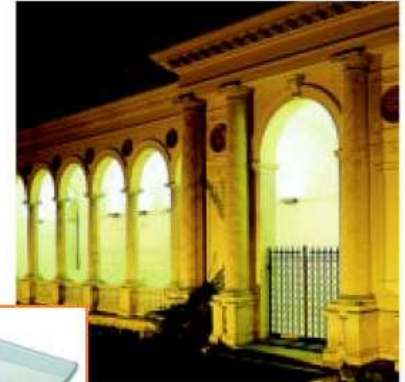

## Ypsilon

- Timeless design and sophisticated technology are the secrets of ypsilon's success. This system can be installed in single or continuous rows. Surface, suspended or wall mounted with a wide variety of fluorescent options and optics including up and downlight, louvred and diffused, whilst also incorporating wire-ways on either side, and can be fitted with integral emergencies and stand alone lighting controls all within its uniquely 'interior designer' lines.





## Light

- Light is a suspended luminaire available in two sizes with a variety of colour options to the bodies and accessories. This luminaire was devised primarily for the retail trade, where, by suspending the light source closer to the merchandise, the lighting designer could use far fewer luminaires, and create an 'all round' globe of light, rather than a blanket of light. Lamp sources vary from the 32w TC-D upto the powerful 250w Metal Halide.



## Designers Light:

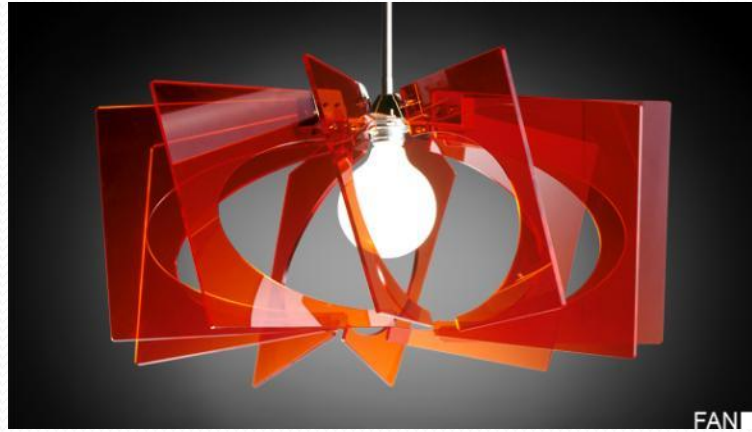







[townlite.en.alibaba.com](http://townlite.en.alibaba.com)

# Interior Lighting















## Light for the future

### **AERO II Hybrid – The best of two worlds**

- In unveiling its new AERO II Hybrid pendant luminaire, Zumtobel presents office lighting of the future. This luminaire combines two efficient light sources which power a system that sets new standards.



## Light expanding spatial limits SCONFINE luminaire..

- With the new SCONFINE luminaire range
- a series of wall-mounted, ceiling-mounted and pendant luminaires.

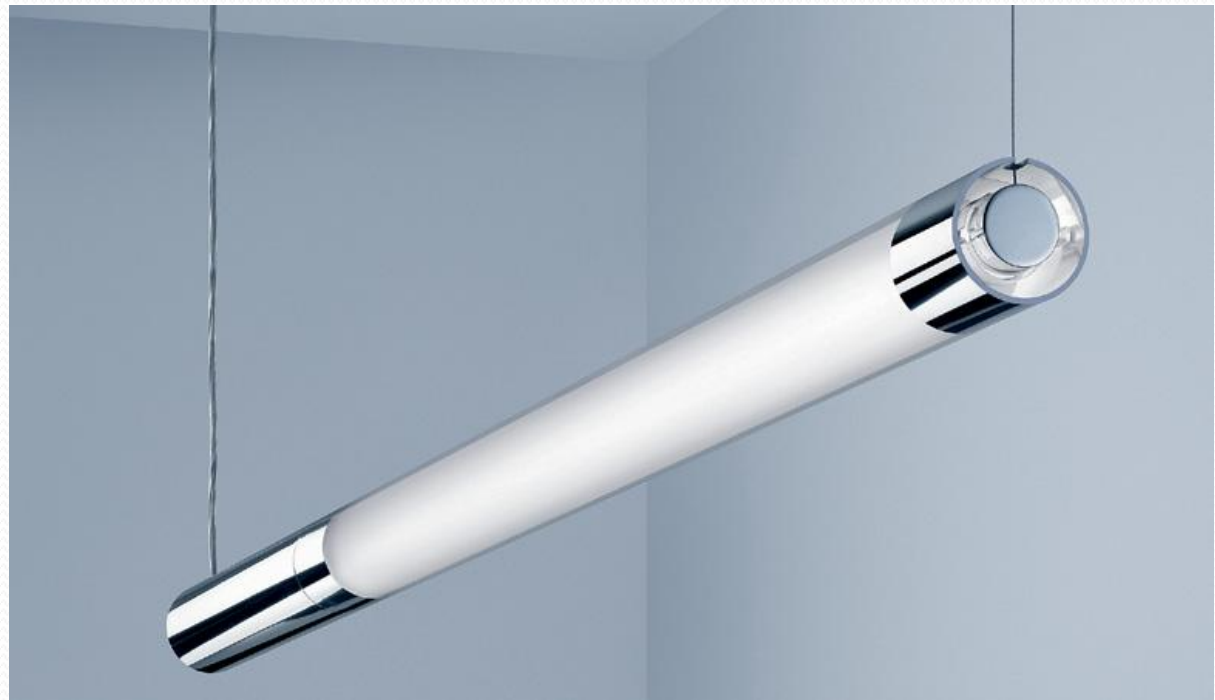



**Multifunctional SUPERSYSTEM luminaire range**  
**Minimum use of materials - maximum lighting comfort**

- Using Zumtobel's multifunctional SUPERSYSTEM lighting system, complex lighting solutions can be implemented in a design that is reduced to pure functionality.



## **HELISSA**

- The HELISSA wall and ceiling-mounted luminaire is now also available with protection type IP 65, ensuring a consistent design in both indoor and uncovered outdoor areas.





**The ARCOS spotlight range**  
**Functional design – maximum lighting convenience**

- Zumtobel's new ARCOS spotlight and wallwasher system provides architects and designers with a complete range of spotlights fitted with various optics to light museums, art galleries and shops perfectly.



## **CIELOS modular luminous ceiling Modular lighting system**

- The CIELOS extra-low profile, individually combinable lighting modules make designing and maintaining luminous ceilings amazingly straightforward. They are especially suitable for smaller and prestigious applications.



## **Downlight system 2LIGHT** **Simply sensuous**

- Nothing less than revolutionary in aesthetics, and innovative in lighting technology and ergonomics – 2LIGHT, the new square downlight system, takes the stage.



## Special Products 07/08

### A wide range of special features

- Conceived by architects, designers and lighting designers, realised by Zumtobel. These project luminaires are something special – in terms of design, lighting technology or application.



## **SCUBA moisture-proof luminaire system Specialist luminaire for harsh conditions**

- SCUBA always provides perfect lighting conditions even under the most demanding environmental conditions and also boasts reliable protection against external influences and chemicals.



## **TUBILUX IP67**

### **One luminaire for any situation**

- Light out of a tube: TUBILUX, the slim, robust tubular luminaire for difficult areas of application, defies even the harshest weather and environmental conditions thanks to top-quality materials











Automation House

## **VIVO Spotlight system**

### **Precision through three hundred and sixty degrees**

- VIVO features intuitive, ergonomic luminaire design. Its special feature is a clip built into the housing that makes moving VIVO in any direction and locking it child's play.



## **MELLOW LIGHT IV**

### **Surface-mounted and recessed luminaire**

- The sophisticated direct/indirect light ratio with sufficient shadow detail and contrast rendition – which is characteristic of the fourth generation of MELLOW LIGHT.

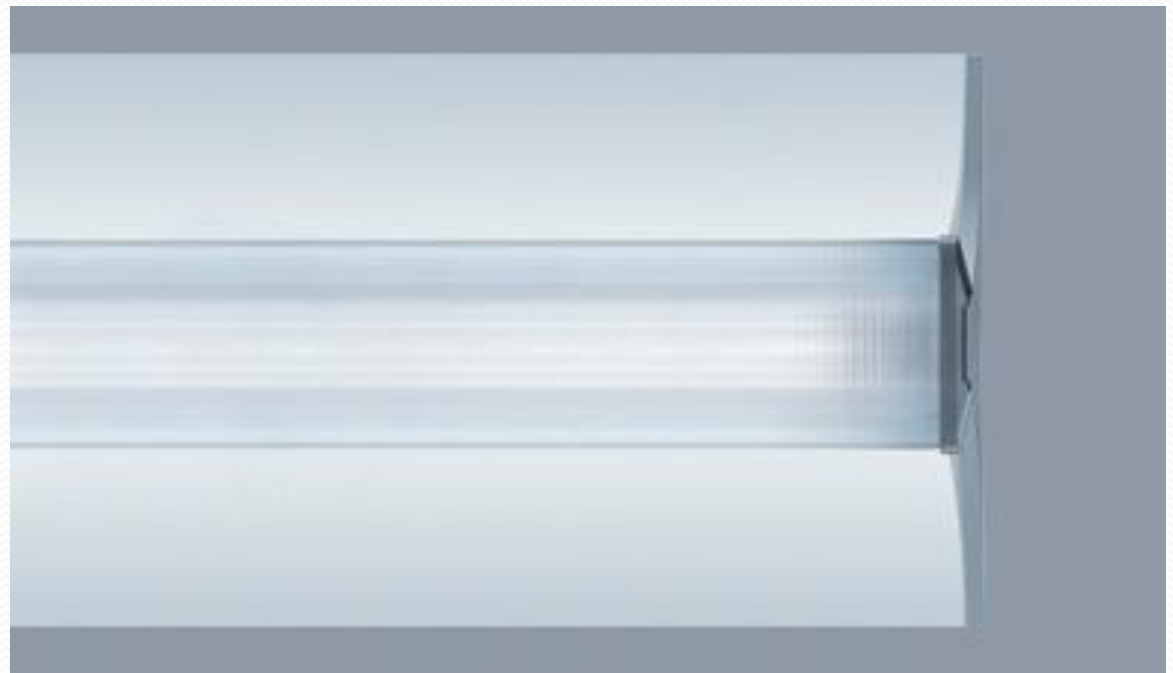

## **CLARIS II**

### **Reduced minimalism with innovative cell louvre technology**

- CLARIS II is a classic which sets new trends: with its minimalist design, this modular lighting system blends unobtrusively into any architecture.



## **VIVO-S and VIVO-SL recessed spotlights** **Flexible ceiling modules**

- From downlighting to accent lighting with 360° precision – the new Zumtobel's swivelled-in spotlight modules provide maximum possible scope to meet every requirement.



## **PANOS Q downlight**

### **The logical consequence of straight-line thinking**

- The square PANOS Q downlight by Zumtobel is the latest member of the PANOS family of high-quality, high-tech downlights and represents a genuine design alternative to its circular relatives.



## **Dimming On Demand** **A giant step into design freedom**

- Either ... or? The answer of the future is: On Demand. Dimmability and other luminaire functions are enabled as and when required, freeing users from the constraint of having to fix specifications in advance.

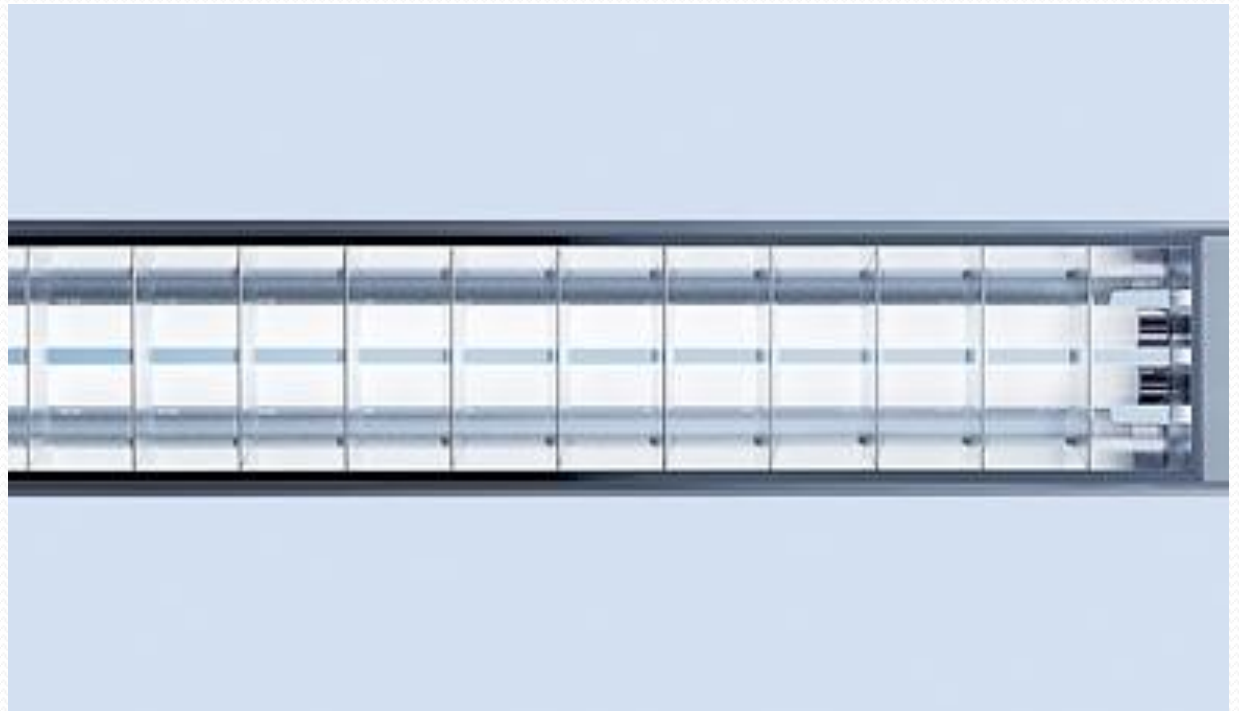

## **CLEAN clean-room luminaire**

### **Three-level luminaire concept for clean-rooms**

- Excellent lighting for medical and industrial progress:  
For the CLEAN product range, the experience of clean-room designers was used and combined with state-of-the-art lighting technology.

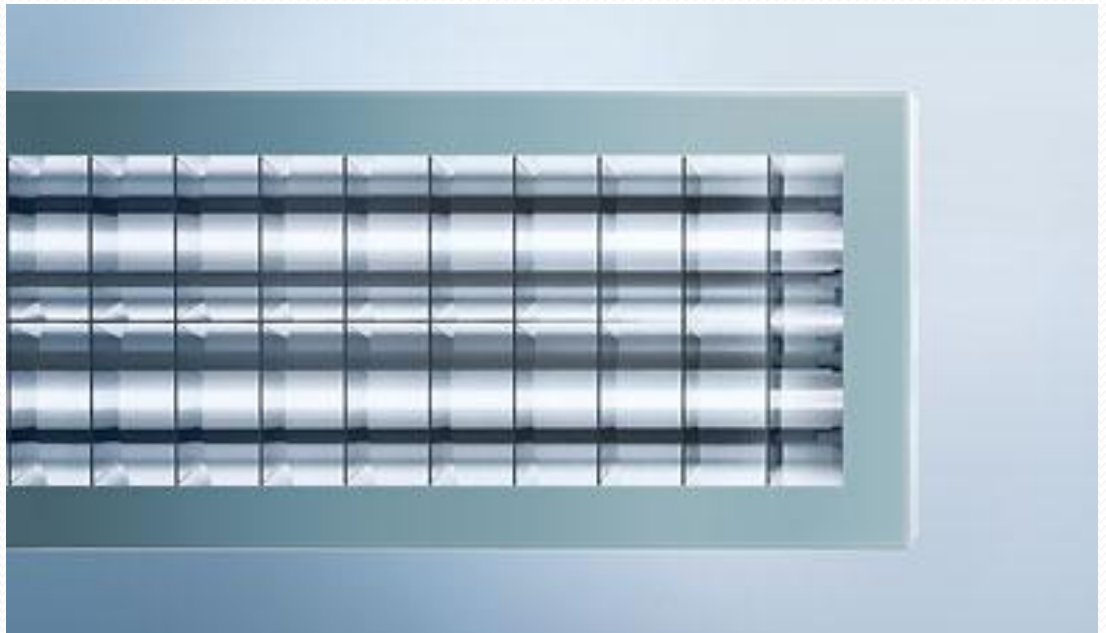



## **PASO II recessed floor luminaire** **Lighting competence at every step and turn**

- PASO II knows how to hit the right buttons when it comes to setting dramatic contemporary lighting scenes whilst nevertheless remaining unobtrusive itself. Modern technology does not interfere with classic architecture.



## **EVIO pendant luminaire** **Manifestly different**

- The persuasive appeal of its look is due to materials which we have grown accustomed to in architecture and to its smoothly flowing forms. EVIO pendant luminaire sets standard in sophisticated offices and reception areas

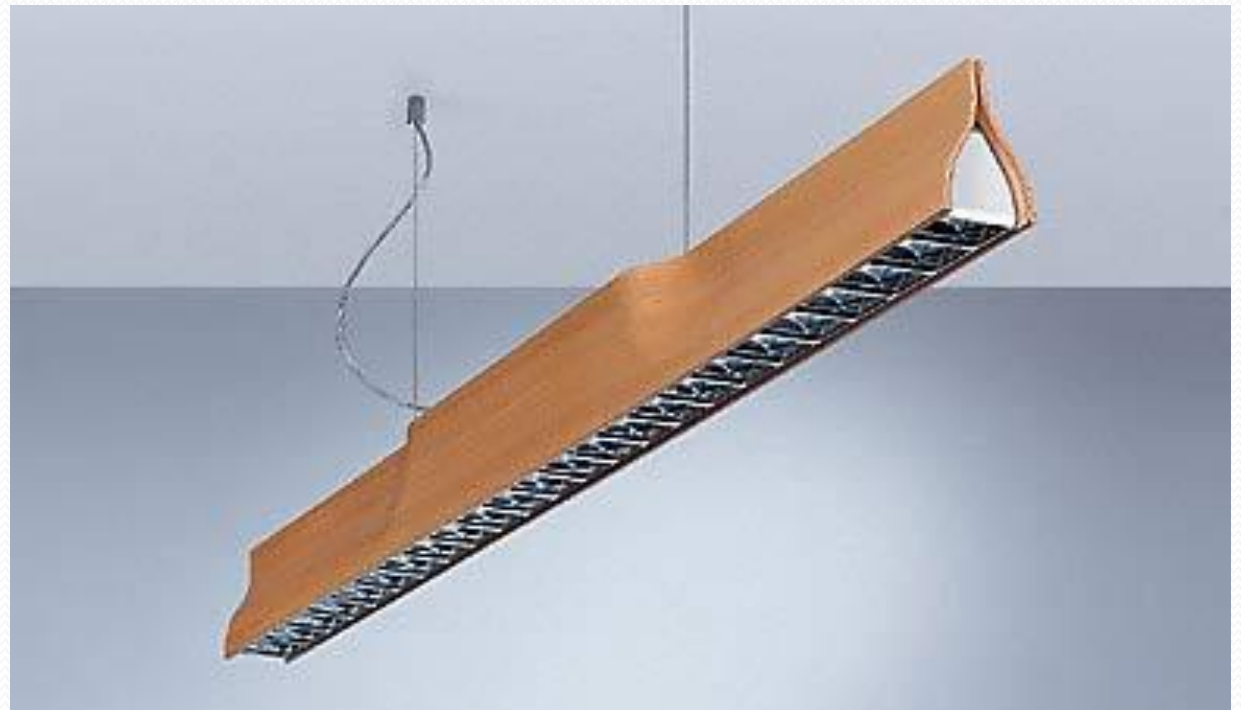

## **CARDAN-SPIRIT luminaire range**

### **Flexibility for lighting and creating accents**

- Their distinctive and angular appearance seems to be the most conspicuous feature of the new CARDAN-SPIRIT luminaire range. The fact that they are closely related to the SPIRIT spotlight range opens up numerous options.

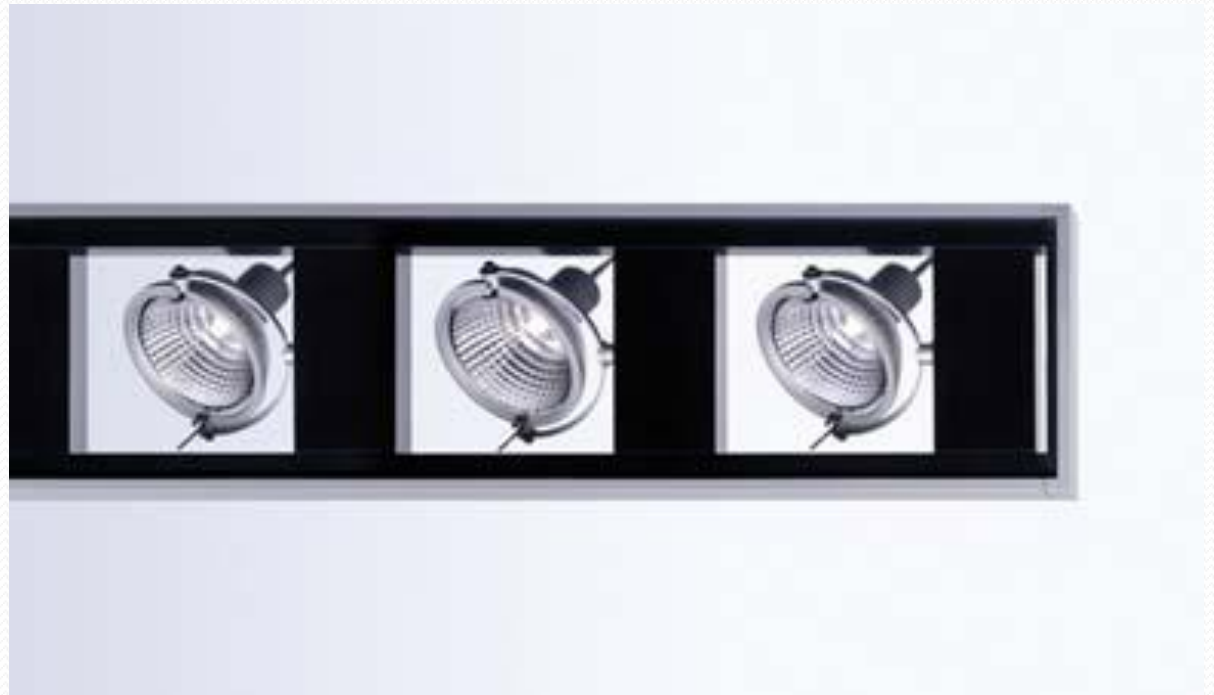

## **SOLAR II spotlight system**

### **Streamlined elegance**

- With the SOLAR II system, a new spotlight generation is born. Its unconventional organic design (created by Massimo Iosa Ghini) makes it a striking, self-assured lighting tool.



**LIGHT FIELDS modular micro-pyramidal lighting**  
**Pure innovation for the office**

- The LIGHT FIELDS lighting system designed by Sottsass Associati, a complete range fitted with micro-pyramidal optic, has been extended by the new MINI LIGHT FIELDS compact version.



## **TECTON continuous row lighting system Fit for the IT age**

- The TECTON continuous-row lighting system designed by Nicholas Grimshaw & Partners is a product of aesthetic merits, great versatility and fit for modern lighting management technologies.





**RTX II design-oriented continuous row system  
Avant-garde in terms of both material and shape**

- RTX II (designed by Charles Keller) is avant-gardist in terms of both material and shape, featuring advanced lighting technology for glare-free light, and extremely efficient thanks to its purely direct distribution characteristics.





## **STARFLEX modular fibre optic system** **The new generation of optical string technology**

- Optical string and fibre optic technology is one of the most fascinating options of precise technical lighting. STARFLEX represents the new generation of optical string technology.
- Optical string and fibre optic technology is one of the most fascinating options of precise technical lighting. The wide range of applications comprises the illumination of shops, museums and galleries as well as lighting in hotels, restaurants or wellness areas. Separating light from electricity as well as from UV and IR components opens up innumerable options, e.g. if priceless valuables are to be perfectly, yet gently lit.

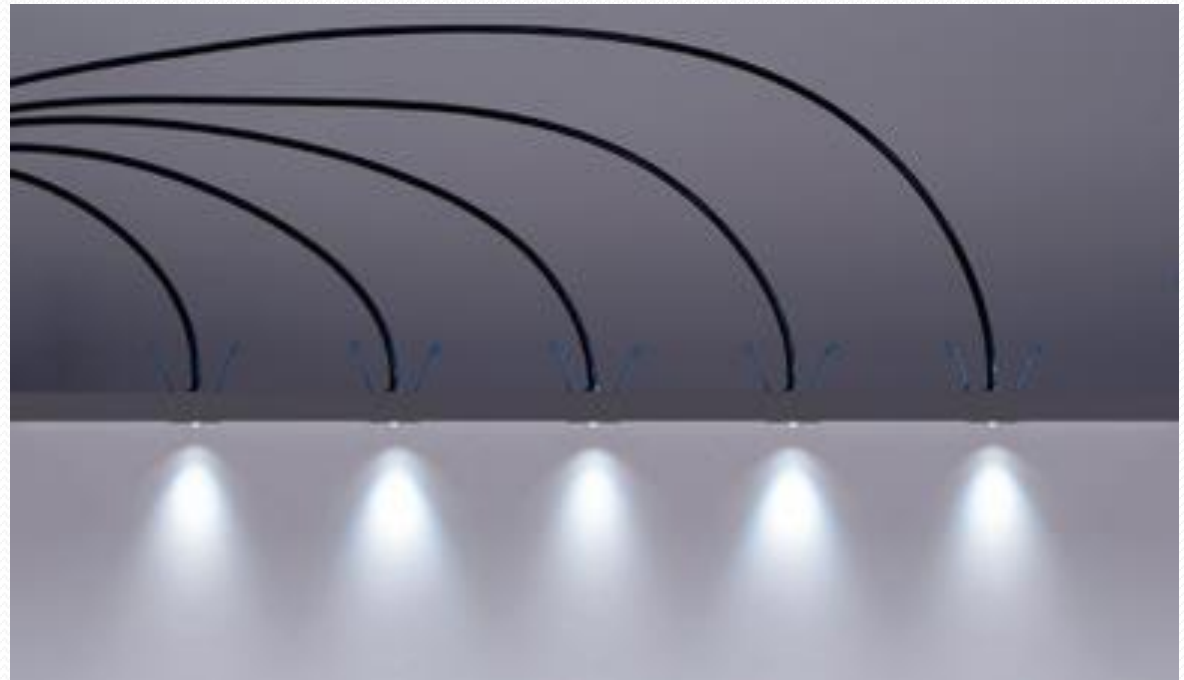

## **LIGHTTOOLS modular lighting system** **More than just a lighting channel**

- "What is most important is the light, and not the luminaire" – this is what French architect and designer Jean-Michel Wilmotte believes in. The LIGHTTOOLS lighting system is consistently based on this philosophy.



## **XENO spotlight system** **One design, many accents**

- XENO (designed by Jean-Michel Wilmotte) stands for a design-oriented generation of spotlights for professional applications - the perfect solution for presentation and accentuation.



## **PANOS M, MWW and S downlights** **Complete range of aesthetic merits and exquisite design**

- Tried and tested lighting technology, a novel concept and innovative materials – this is the secret of success of the products recently added to the PANOS range: PANOS M, PANOS MWW and PANOS S downlights



## **PANOS downlights** **Sophisticated variety – uniform image**

- The PANOS complete downlight program is characterised by a sophisticated modular concept and the unmistakable design language developed by Sottsass Associati.

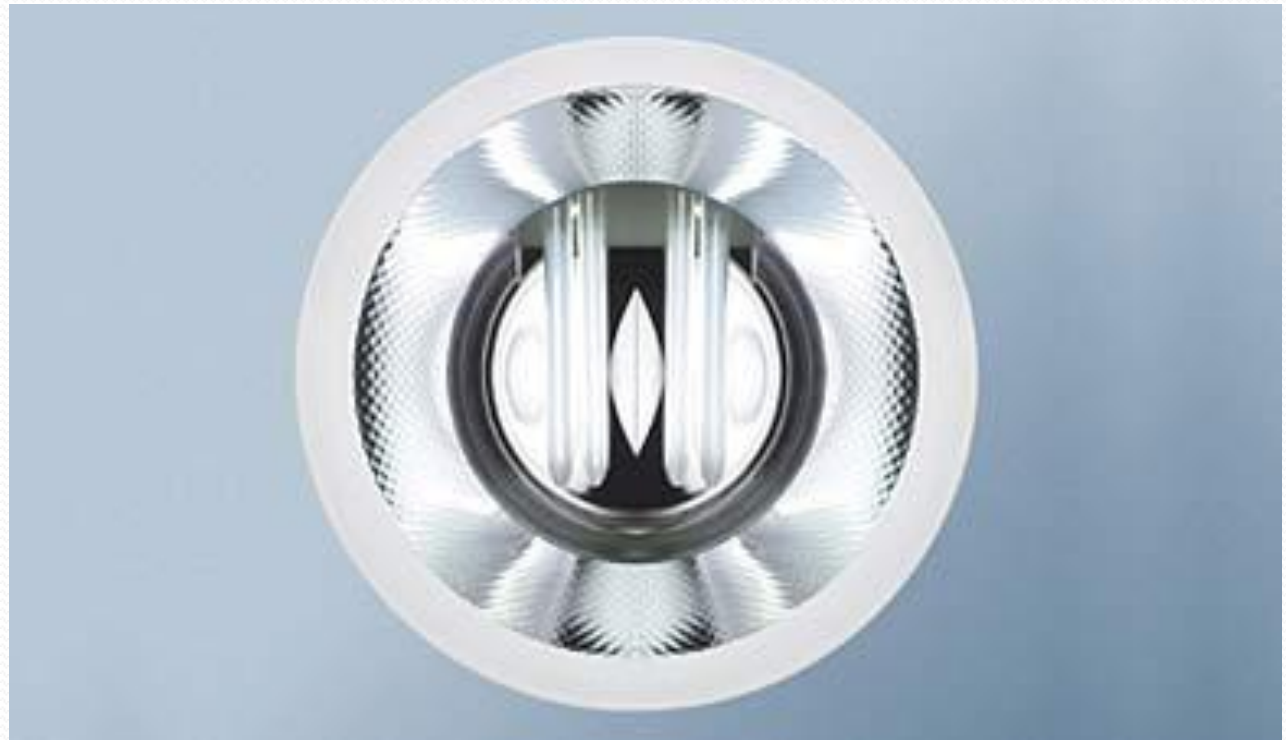

## **RAIN moisture-proof batten luminaire For difficult conditions**

- Wherever unpleasant conditions prevail, with dirt and water being a challenge to the lighting solution, the RAIN moisture-proof batten luminaire feels at home.





- This is avenue K Mall, the atrium void is simply an awesome space rising some twenty metres, with an escalator connecting directly between the ground floor and level three.



lighting concept is minimalist, preserving a pristine and luxurious ambience to this museum like interior.



Materials

Acrylic

Dimensions

Each light stick 68cm high

Care Guide

Mains operated by one transformer plug.

These ingenious **Electrical Stick Lights** create a magical, starry effect indoors or out. A detachable stake allows you to put them in the ground or even in plant pots. Perfect for illuminating paths or adding an enchanting glow to specific areas. Mains operated by one transformer plug. (Pack of ten on a wire).



Materials

Made of fully-recyclable plastics

Dimensions

Size: 6.35cm wide x 15.5cm high

Care Guide

Energy-efficient LED light source. Portable and rechargeable. Child-friendly. Great indoors or outdoors. Water-resistant. Each set includes two lamps (White) and one charger giving 5 to 8 hours of light.

**Candela Cloud 4 Lamp Set.** These award winning portable lights provide a warm ambient glow that won't blow out in the wind, or set the house alight if left unattended. Equally useful on the dinner table or bedside, Candela rechargeable lights replace hundreds of pounds worth of wax candles and they're cleaner, safer, and easier to use.





Roger borg neon lamps

# Led's

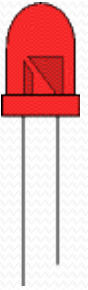

- Light Emitting Diodes (LEDs) are rapidly replacing Incandescent lighting for many applications.
- Most traffic lights have been replaced with LED's and many of today's new cars are equipped with LED tail lights.
- Solid state lighting (SSL) uses semi-conducting materials to convert electricity into light. It is the first truly new lighting technology to emerge for many years. SSL is an umbrella term encompassing different types of technologies including light-emitting diodes (LEDs) and organic light-emitting diodes (OLEDs). While both technologies are evolving rapidly, LEDs are the more mature technology, particularly for white-light general illumination applications.

- **L.E.D.'s - What Are They & What Do They Do?**
- The term L.E.D. stands for **Light Emitting Diode**. Modern electronics relies heavily upon L.E.D. light bulbs. For instance, L.E.D.s transmit information from remote controls, are used in traffic lights, digital L.E.D. clocks, flashlights, and to form images on jumbo television screens.
- L.E.D. light bulbs are miniature bulbs that do not use filaments to produce light. Therefore, the life of an L.E.D. is much longer than that of a regular incandescent bulb

# Advantages:

- **Efficiency:** LEDs produce more light per watt than incandescent bulbs.
- **Color:** LEDs can emit light of an intended color without the use of color filters that traditional lighting methods require. This is more efficient and can lower initial costs.
- **Size:** LEDs can be very small (smaller than 2 mm<sup>2</sup>) and are easily populated onto printed circuit boards.
- **On/Off time:** LEDs light up very quickly. A typical red indicator LED will achieve full brightness in microseconds.-LEDs used in communications devices can have even faster response times.
- **Cycling:** LEDs are ideal for use in applications that are subject to frequent on-off cycling, unlike fluorescent lamps that burn out more quickly when cycled frequently, or HID lamps that require a long time before restarting.
- **Dimming:** LEDs can very easily be dimmed either by Pulse-width modulation or lowering the forward current.
- **Cool light:** In contrast to most light sources, LEDs radiate very little heat in the form of IR that can cause damage to sensitive objects or fabrics. Wasted energy is dispersed as heat through the base of the LED.
- **Slow failure:** LEDs mostly fail by dimming over time, rather than the abrupt burn-out of incandescent bulbs.
- **Lifetime:** LEDs can have a relatively long useful life. One report estimates 35,000 to 50,000 hours of useful life, though time to complete failure may be longer.-Fluorescent tubes typically are rated at about 10,000 to 15,000 hours, depending partly on the conditions of use, and incandescent light bulbs at 1,000–2,000 hours.
- **Shock resistance:** LEDs, being solid state components, are difficult to damage with external shock, unlike fluorescent and incandescent bulbs which are fragile.
- **Focus:** The solid package of the LED can be designed to focus its light. Incandescent and fluorescent sources often require an external reflector to collect light and direct it in a usable manner.
- **Toxicity:** LEDs do not contain mercury, unlike fluorescent lamps.

# Disadvantages:

- **High price:** LEDs are currently more expensive, price per lumen, on an initial capital cost basis, than most conventional lighting technologies. The additional expense partially stems from the relatively low lumen output and the drive circuitry and power supplies needed. However, when considering the total cost of ownership (including energy and maintenance costs), LEDs far surpass incandescent or halogen sources and begin to threaten compact fluorescent lamps.
- **Temperature dependence:** LED performance largely depends on the ambient temperature of the operating environment. Over-driving the LED in high ambient temperatures may result in overheating of the LED package, eventually leading to device failure. Adequate heat-sinking is required to maintain long life. This is especially important when considering automotive, medical, and military applications where the device must operate over a large range of temperatures, and is required to have a low failure rate.
- **Voltage sensitivity:** LEDs must be supplied with the voltage above the threshold and a current below the rating. This can involve series resistors or current-regulated power supplies.
- **Light quality:** Most cool-white LEDs have spectra that differ significantly from a black body radiator like the sun or an incandescent light. The spike at 460 nm and dip at 500 nm can cause the colour of objects to be perceived differently under cool-white LED illumination than sunlight or incandescent sources, due to metamerism, red surfaces being rendered particularly badly by typical phosphor based cool-white LEDs. However, the colour rendering properties of common fluorescent lamps are often inferior to what is now available in state-of-art white LEDs.
- **Area light source:** LEDs do not approximate a “point source” of light, but rather a lambertian distribution. So LEDs are difficult to use in applications requiring a spherical light field. LEDs are not capable of providing divergence below a few degrees. This is contrasted with lasers, which can produce beams with divergences of 0.2 degrees or less.
- **Blue Hazard:** There is increasing concern that blue LEDs and cool-white LEDs are now capable of exceeding safe limits of the so-called blue-light hazard as defined in eye safety specifications such as ANSI/IESNA RP-27.1-05: Recommended Practice for Photobiological Safety for Lamp and Lamp Systems.
- **Blue pollution:** Because cool-white LEDs (i.e., LEDs with high colour temperature) emit much more blue light than conventional outdoor light sources such as high-pressure sodium lamps, the strong wavelength dependence of Rayleigh scattering means that cool-white LEDs can cause more light pollution than other light sources. It is therefore very important that cool-white LEDs are fully shielded when used outdoors.

# Applications:

- Traffic lights
- Automotive lighting
- Stage lighting
- Bicycle lighting
- Flashlight (Electric torches)
- Domestic lighting
- Public Transit Vehicle Destination signs
- Billboard displays
- Floodlighting of buildings
- Display lighting in art galleries to achieve a low heating effect on pictures etc.
- Train lights and Train Signals (Now common on nearly all modern and most older MU's and Loco's in the UK)

## Colours of LEDs

- LEDs are available in red, orange, amber, yellow, green, blue and white.
- Blue and white LEDs are much more expensive than the other colours

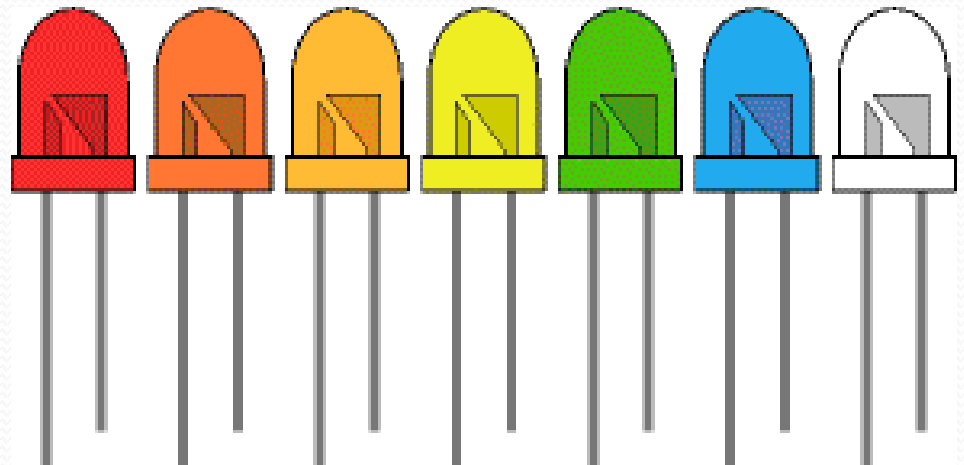

- It is possible to create the entire colour spectrum (64 billion colours) to include white light with these three coloured bulbs.
- How can three coloured bulbs make 64 billion colours?
- Colour mixing is achieved by varying the voltage to each of the red, green and blue bulbs. The controller for the colour mixing may be either an external unit or may be combined on the lighting unit itself.

## Tri-colour LEDs

- The most popular type of tri-colour LED has a red and a green LED combined in one package with three leads. They are called tri-colour because mixed red and green light appears to be yellow and this is produced when both the red and green LEDs are on.

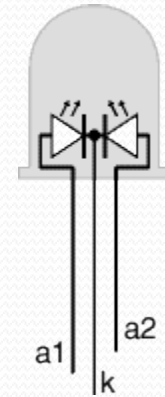

## Bi-colour LEDs

A bi-colour LED has two LEDs wired in 'inverse parallel' (one forwards, one backwards) combined in one package with two leads. Only one of the LEDs can be lit at one time and they are less useful than the tri-colour LEDs described above.



## **Sizes, Shapes and Viewing angles of LEDs**

- LEDs are available in a wide variety of sizes and shapes.
- The 'standard' LED has a round cross-section of 5mm diameter and this is probably the best type for general use, but 3mm round LEDs are also popular.



- Technology

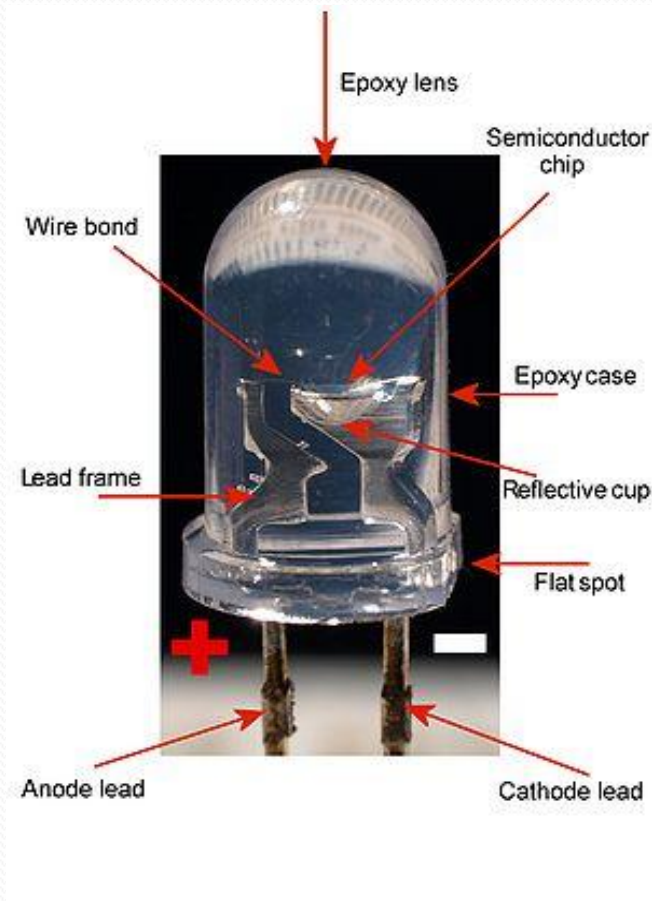

- Working of LED

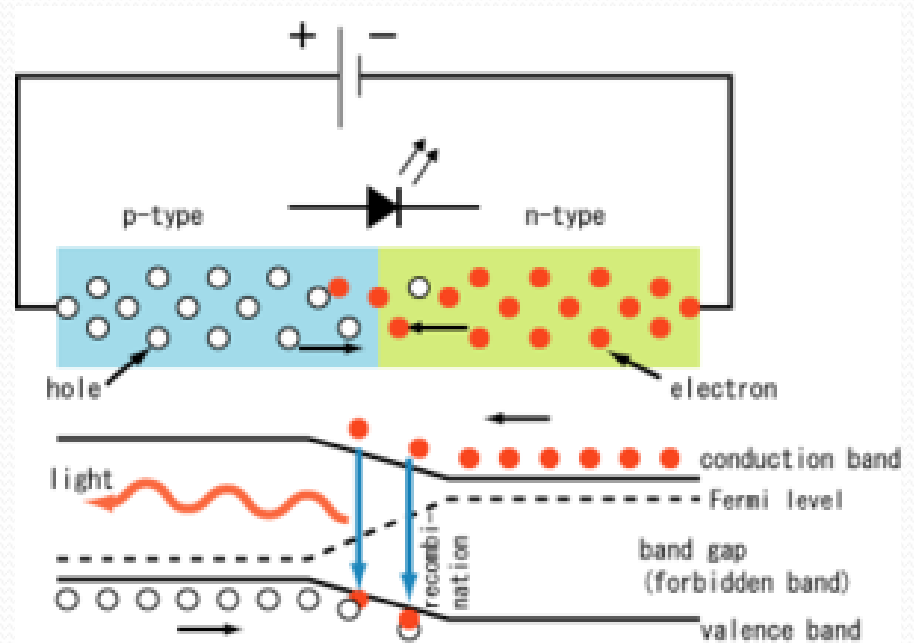

- The inner workings of an LED

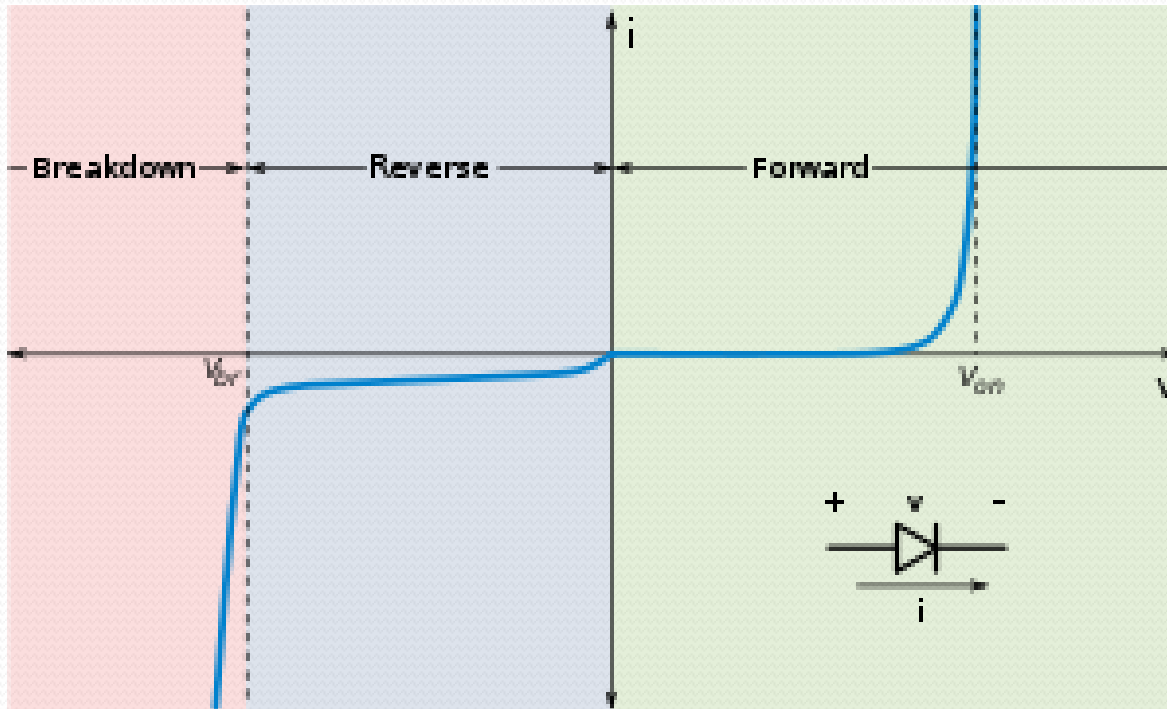

I-V diagram for a diode an LED will begin to emit light when the on-voltage is exceeded. Typical on voltages are 2-3 Volt

## LED Products:

### **SOLINA surface-mounted and pendant luminaire** **Elegant link between light and architecture**

- Fitted with LEDs in RGB colours, the new SOLINA high-bay reflector luminaire provides exciting options for creating colour accents and colour sequences on the ceiling.



**2LIGHT C and 2LIGHT C Mini downlight systems**  
**Innovative lighting technology within minimum space**

- The 2LIGHT downlight range has been extended: as a surface-mounted and recessed luminaire, also available as an LED version, 2LIGHT MINI demonstrates a wealth of unique lighting options.



## RESCLITE LED emergency lighting Less is more

- **April 2008** - Using a power LED and three sophisticated optics, RESCLITE paves the way to a new era of emergency lighting.

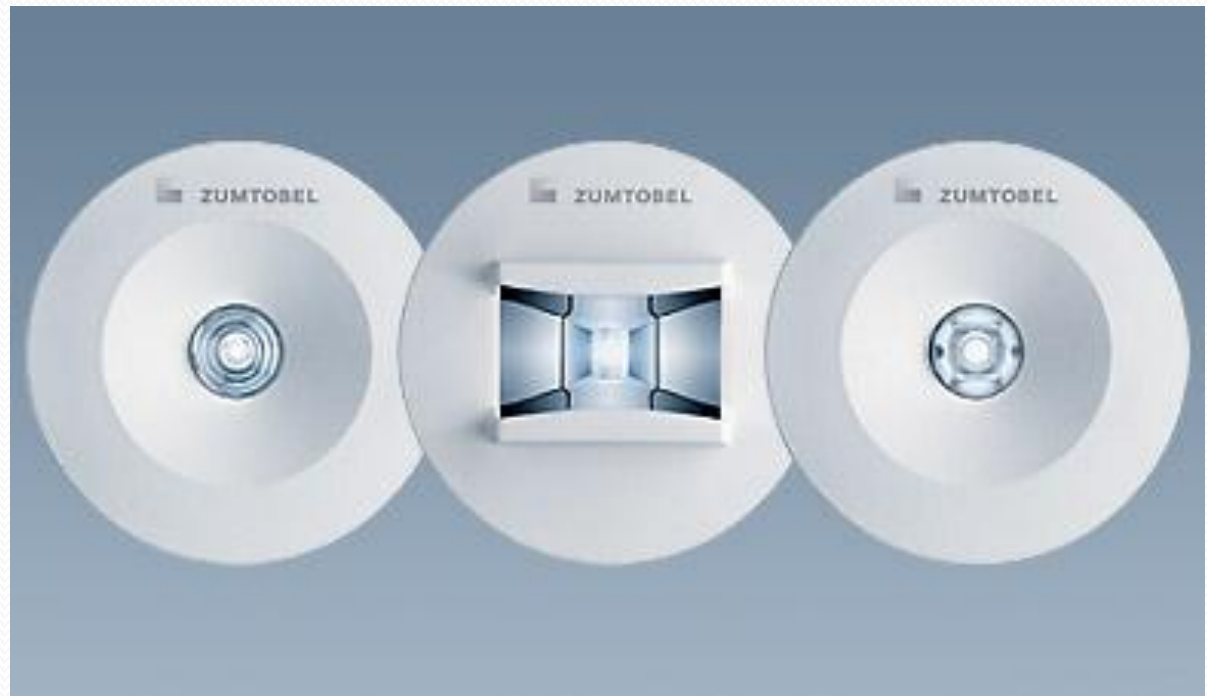

## **TEMPURA LED spotlight** **A revolution in lighting**

- A luminaire with a long service life and low energy consumption. TEMPURA offers all the benefits of advanced LED technology and combines these with unique versatility



**LEDOS LED recessed luminaires**  
**Playing with lighting points in colour**

- The LEDOS LED recessed luminaires cannot fail to impress with a wide range of light colours that can be generated, perfect colour rendition quality and a variety of designs.





- **Ample scope for creative design**

The LEDOS M range includes round recessed wall and floor luminaires as well as bollard luminaires with compact mounting dimensions (Ø 65 mm). Their modular design with different optics opens up ample scope for creative lighting for guidance and decorative purposes.

- **LED pure**

LEDOS Wall are square and round LED recessed wall luminaires which, thanks to their unobtrusive appearance, are perfectly suitable for the marking of corridor areas, for theatre and cinema lighting, for hotel corridors or for traffic direction in multi-storey car parks.

- **Decorative**

Sophisticated lighting accents can be created on walls using KAVA LED recessed wall luminaires. Their light is distributed asymmetrically via a matt specular metal reflector; combined with coloured light, this creates fascinating effects.

- **Ledos RGB - the dynamic world of colours**

LEDOS RGB, the multicoloured addition to the existing LEDOS LED recessed luminaire series oriented towards the use of unicoloured lighting points, provides a variety of new and fascinating applications thanks to its innovative LED technology based on RGB – both within buildings and outside, either as floor or wall recessed luminaires, available as round or square versions. Every 15 seconds, a built-in chip activates pre-programmed colour changes and makes even static rooms and rather sterile circulation areas more dynamic, attractive and lively.

- LED Tube Lights from Spectrum Lighting use up to 70% less electricity than regular lamps. Spectrum Lighting's LED Tube Lights feature high quality LEDs, emitting the same amount of brightness as conventional T series fluorescent lights, but at a substantially reduced cost.

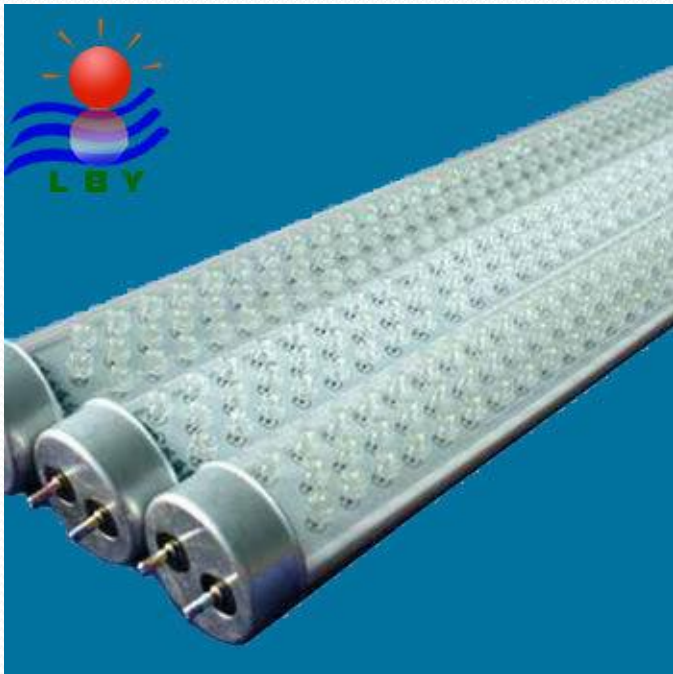



Small led's



Led Bulb

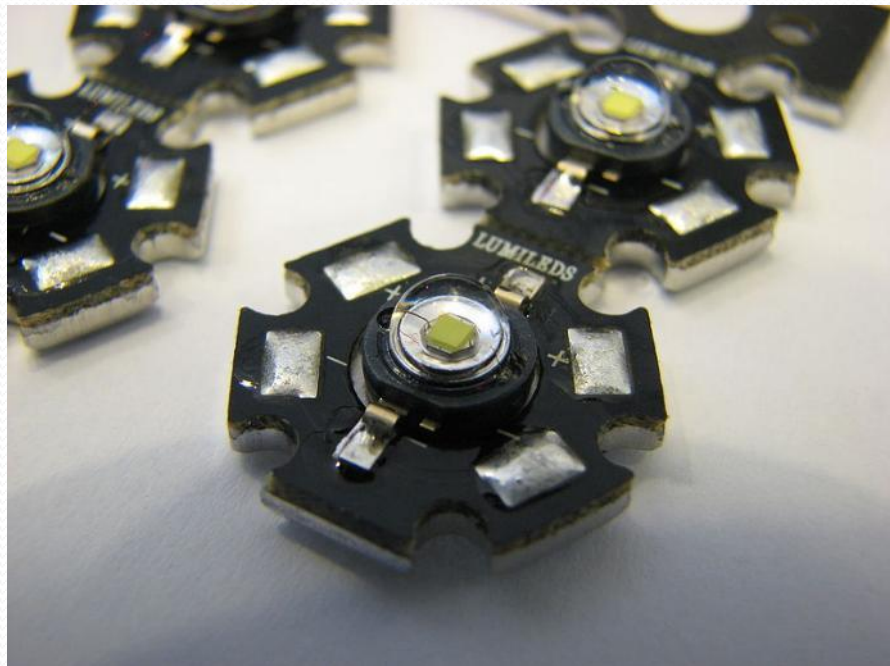

High power light emitting diodes





Blue LED



LED Daytime Running Lights



RGB LED Neon Flex Light



backlit-decorative-wall-panel



led-downlight



LED Indoor Light cree led DC12v



interior-led-beacon-light



led-borderlight



# Design Possibilities

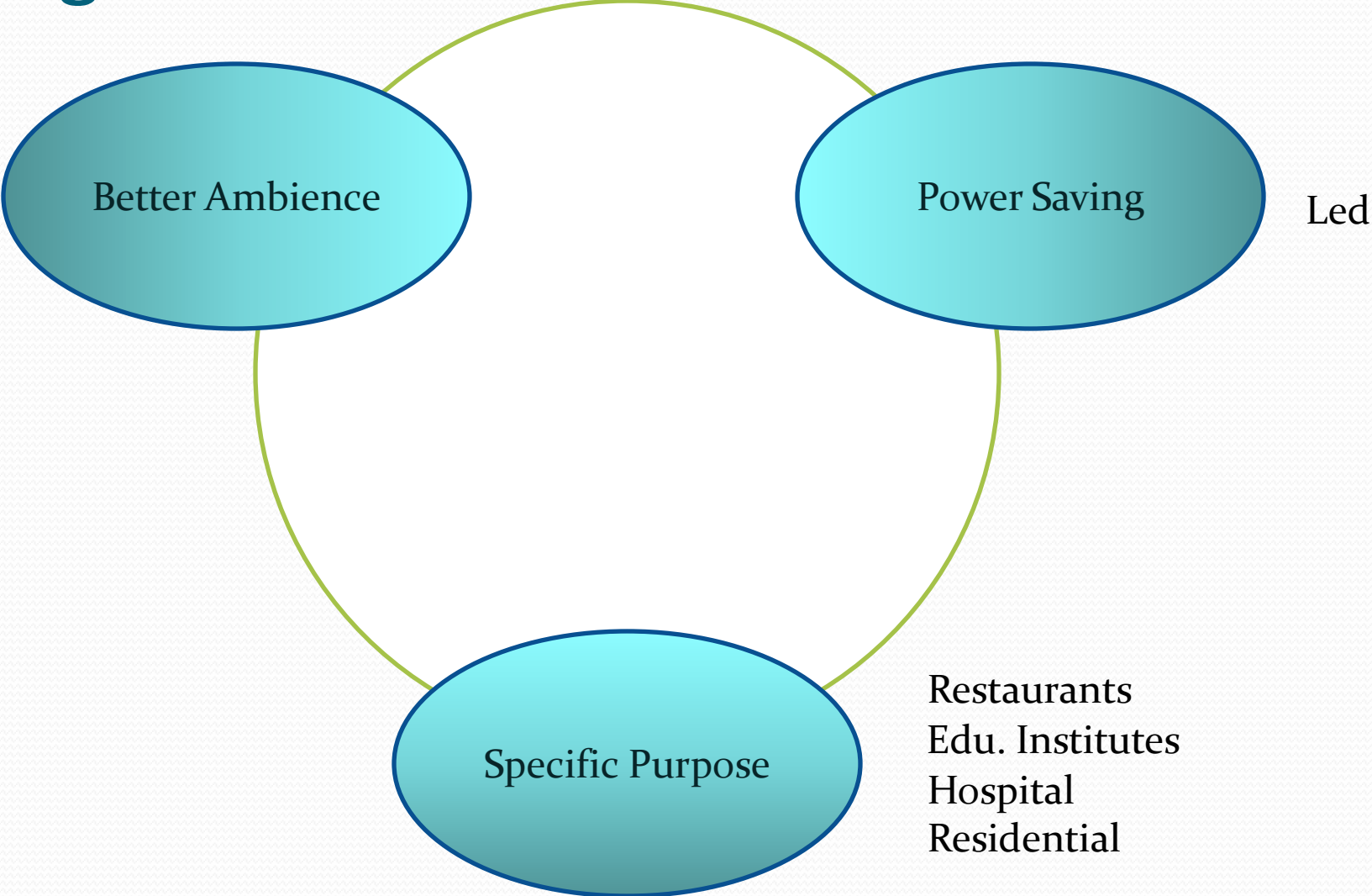

# Cluster 1 - Static

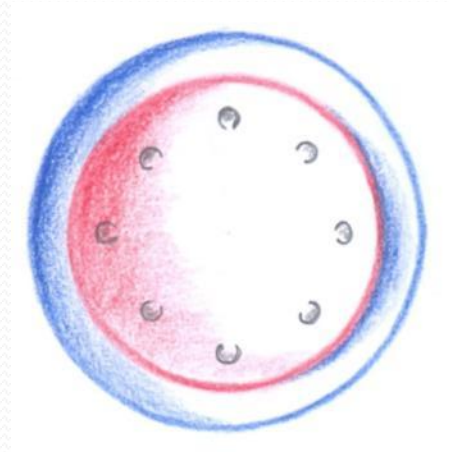
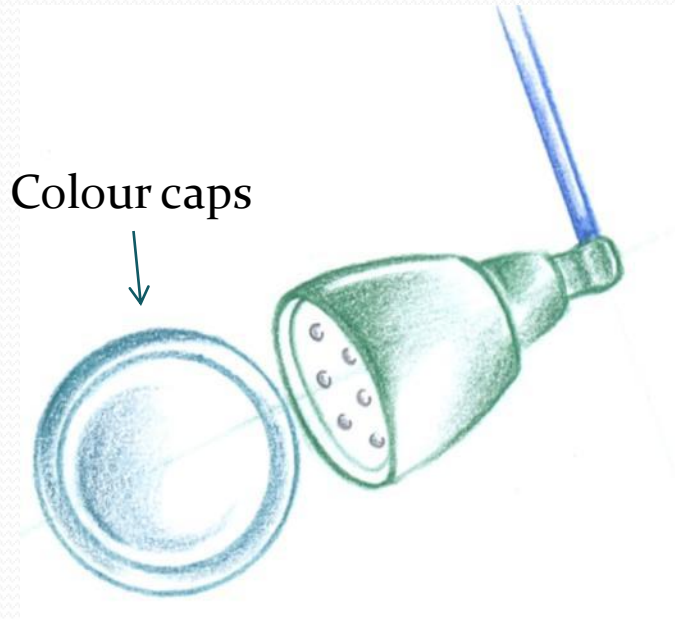

light ball

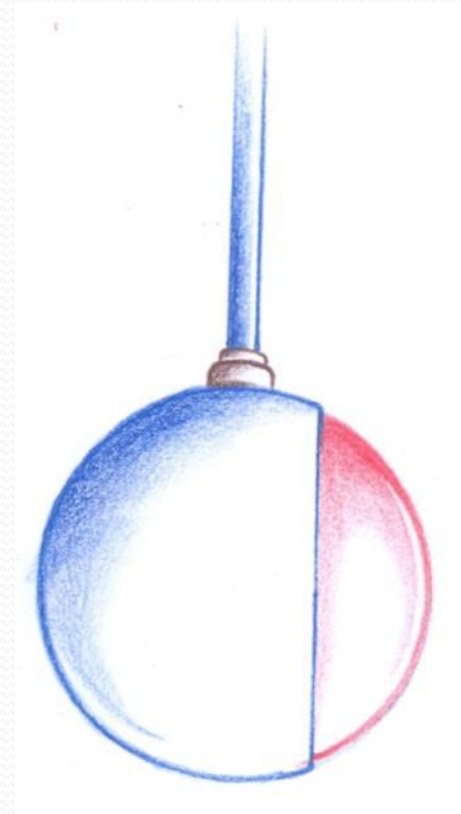

Various design patterns

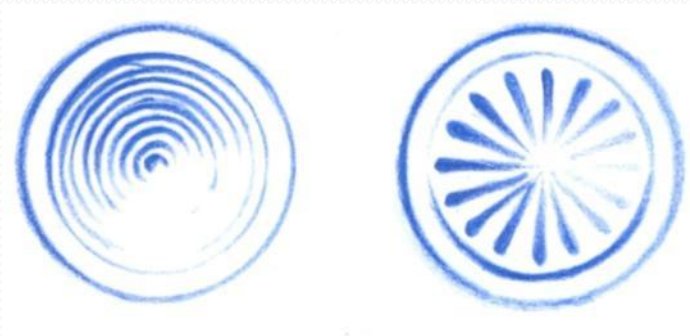

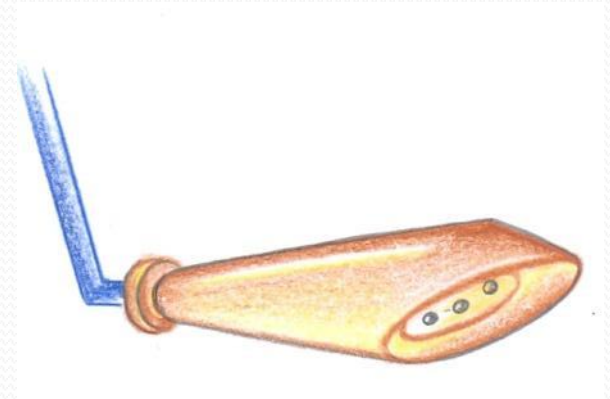
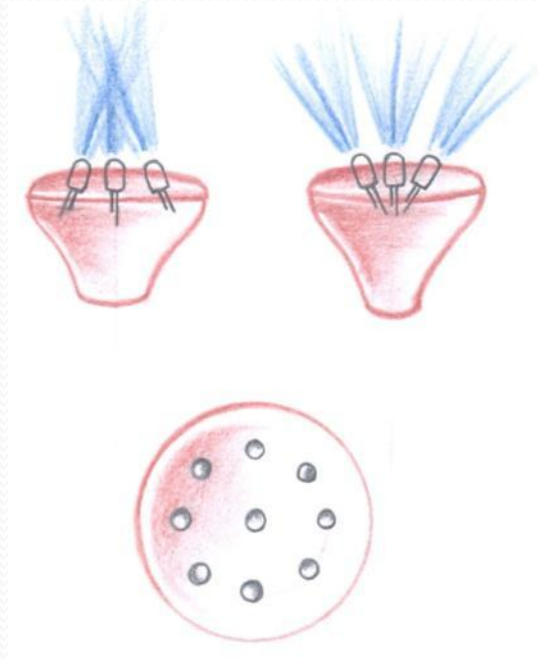
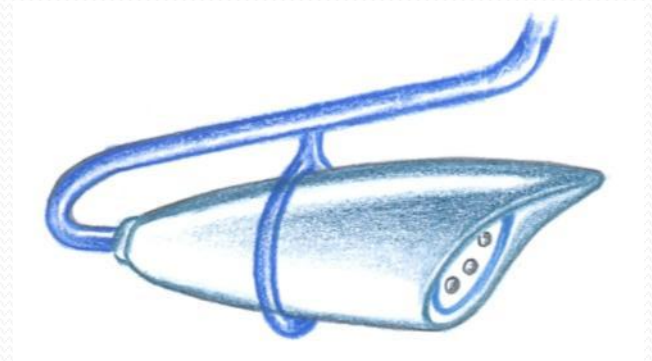

Movable light

Inclining leds

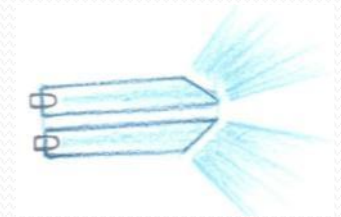
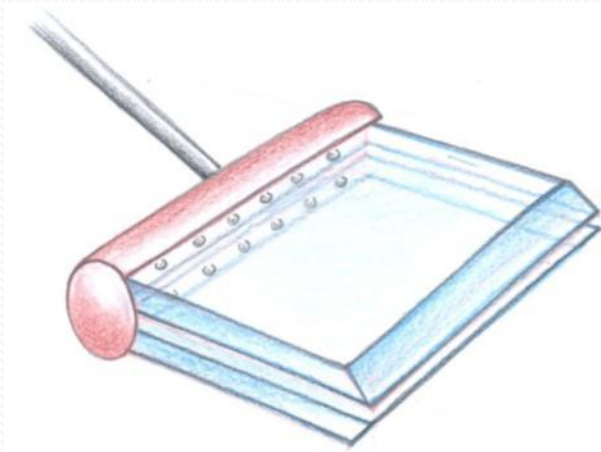
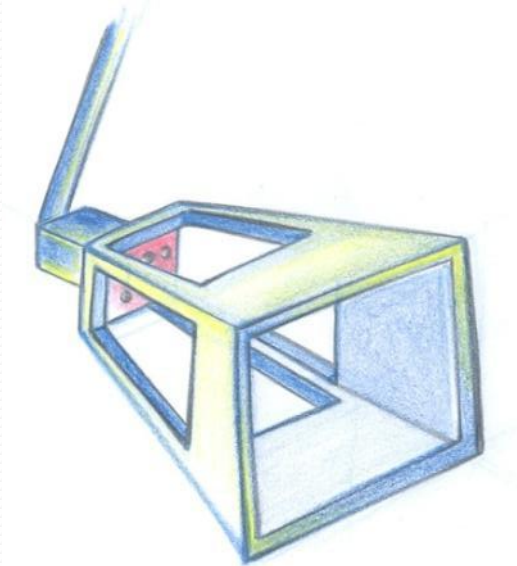

Chamfered acrylic plates

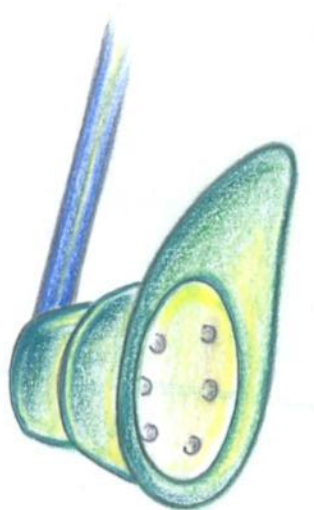

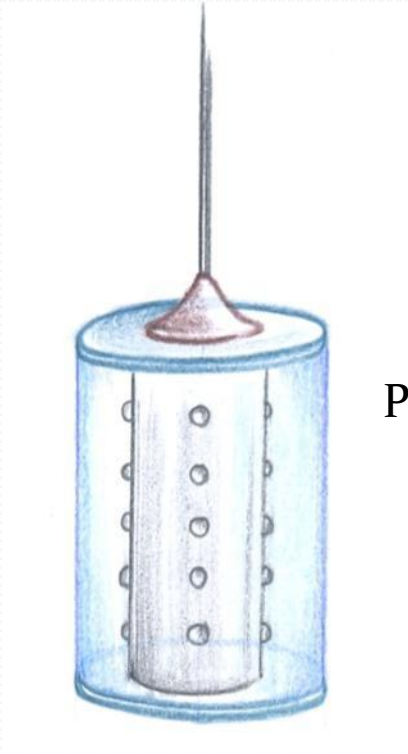

Possibility of various patterns

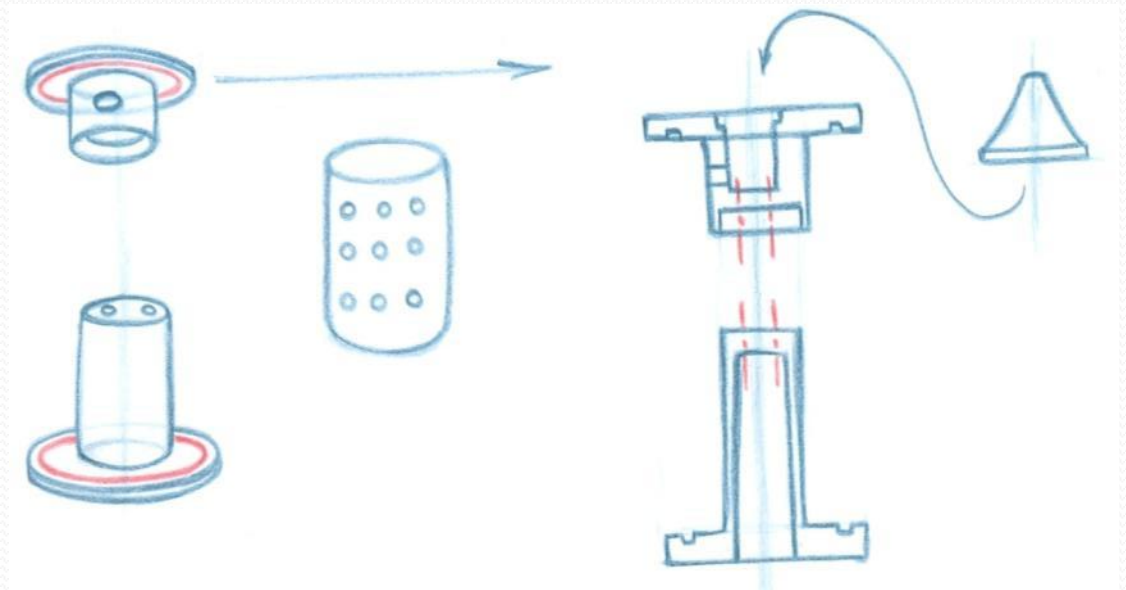

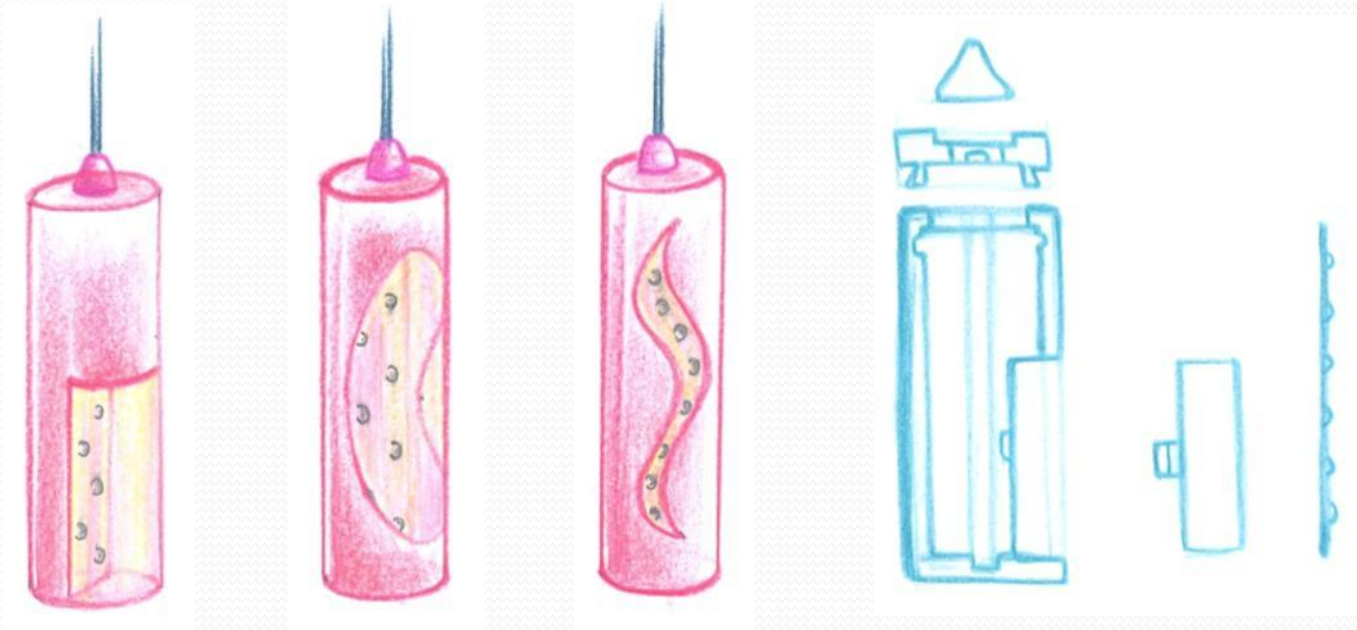

Various design pattern possibility

# Cluster 2 – single or few led's

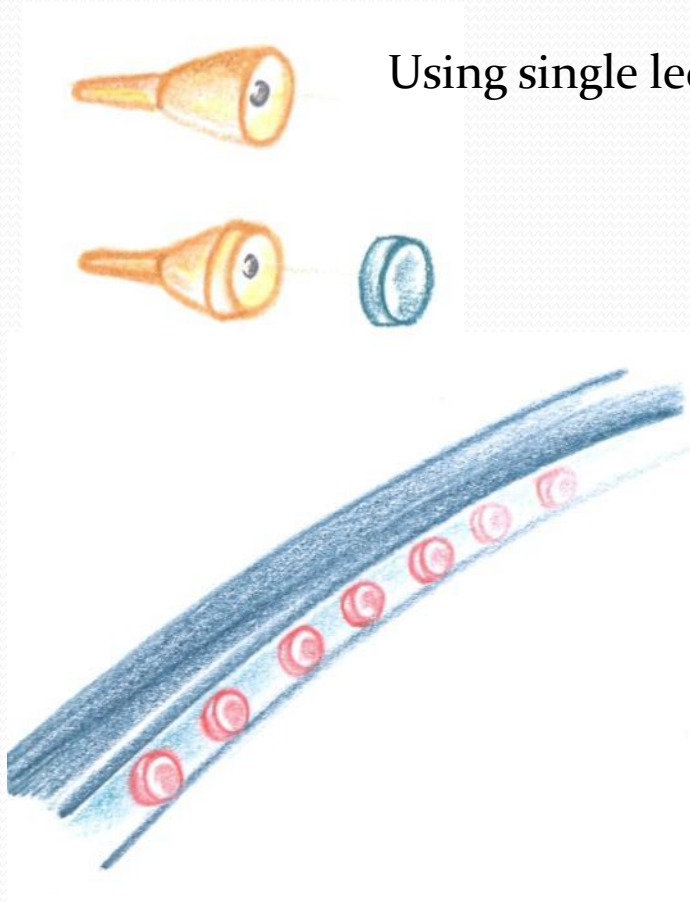

Using single or multiple led

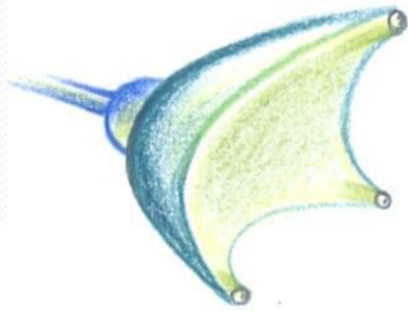

Led on edges

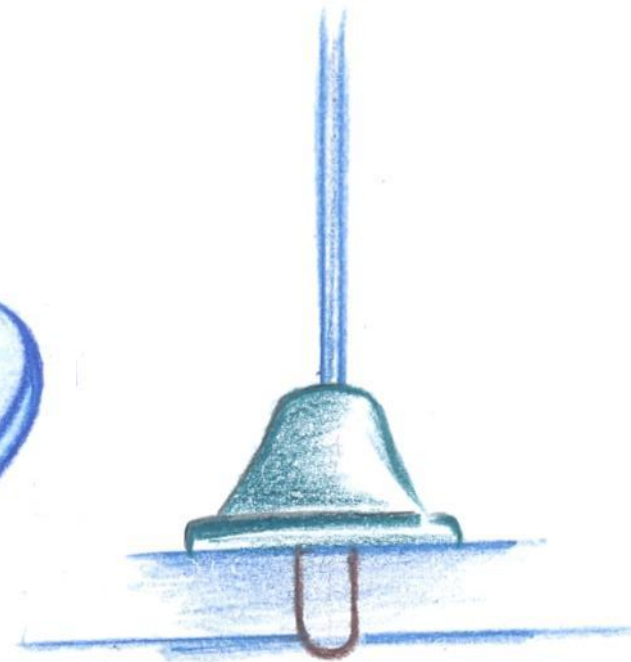
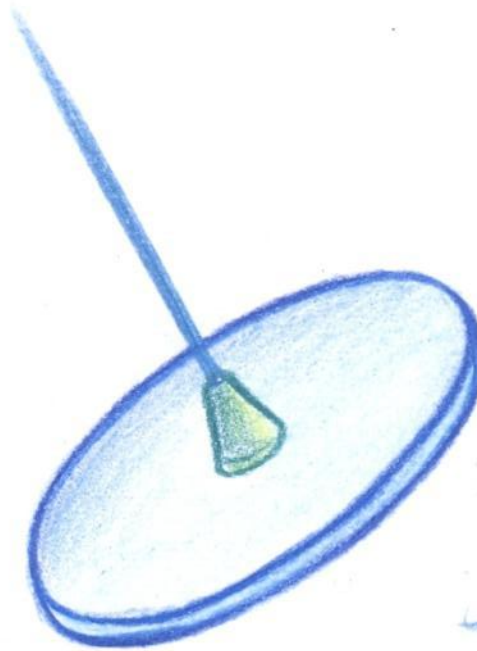

Acrylic plate with led at center



# Cluster 3 - Sliding

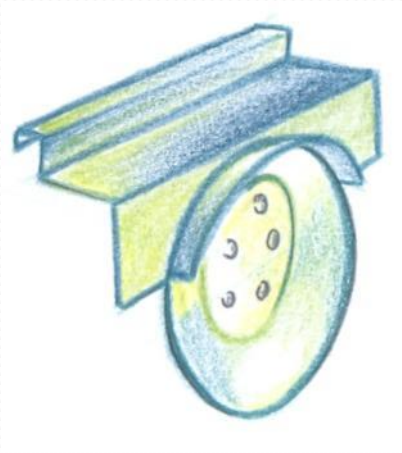

Groove for sliding

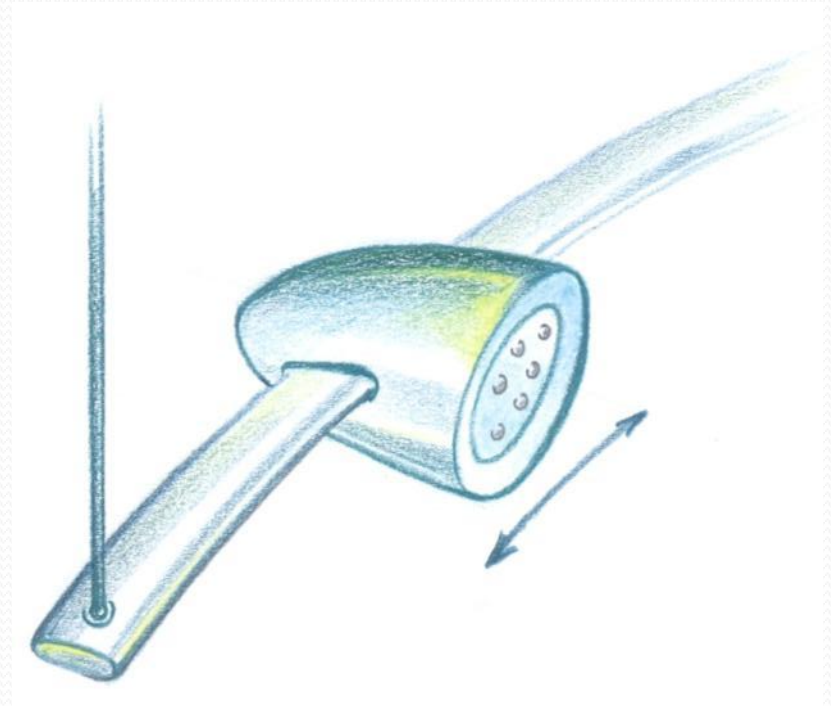

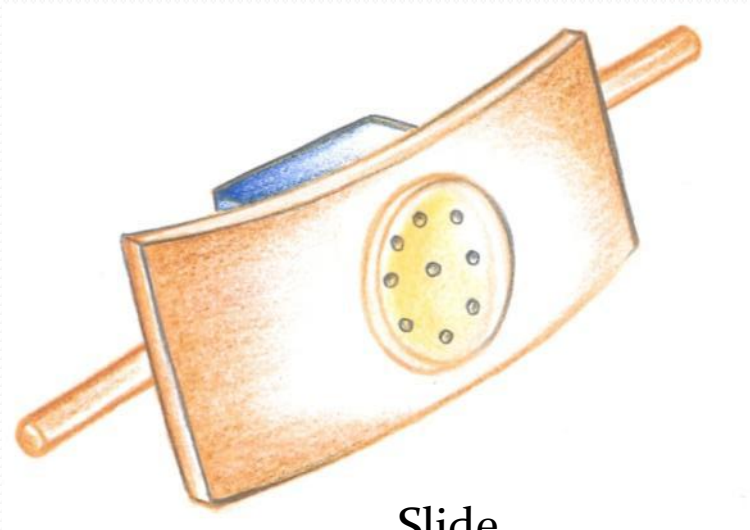

Slide

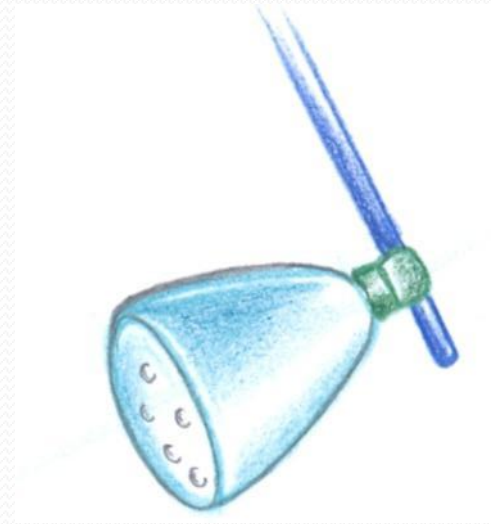

Slide Height adjustable

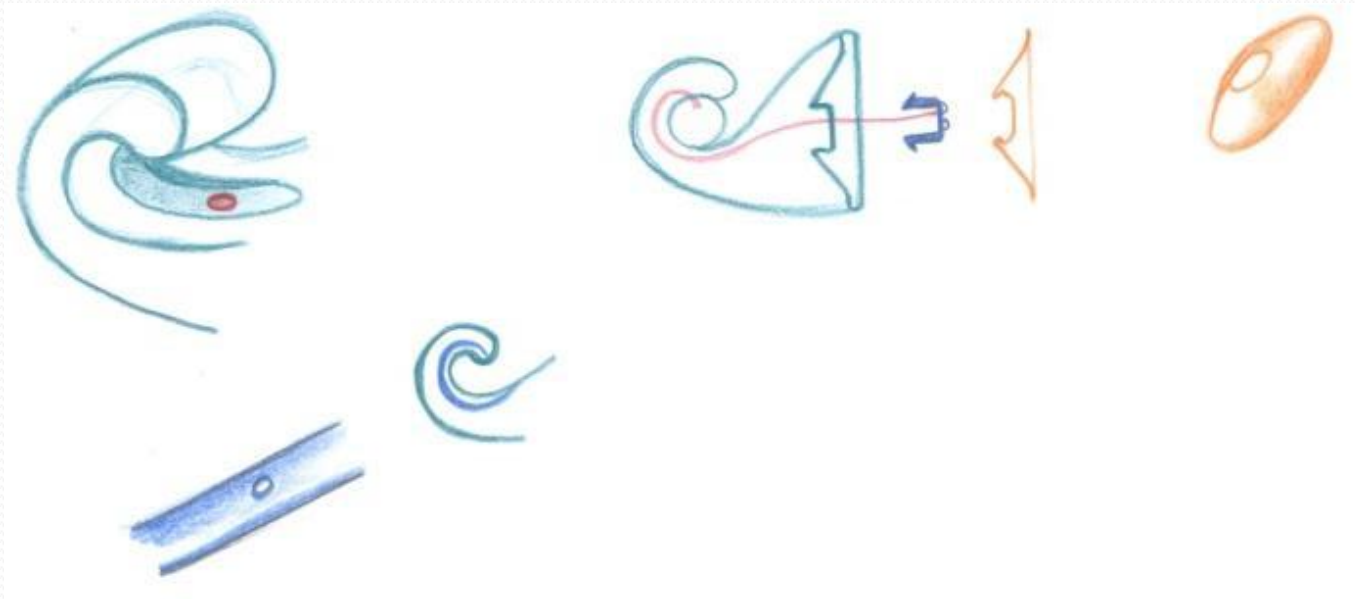
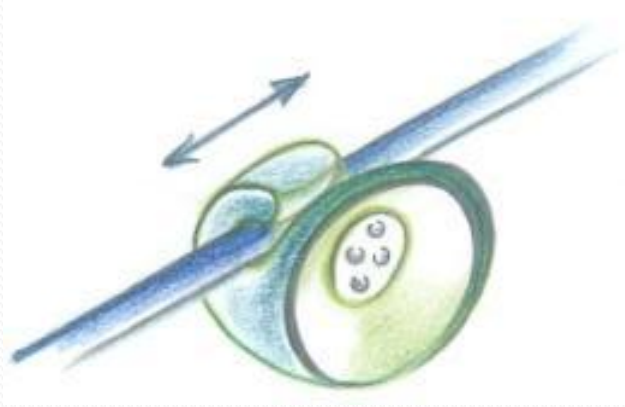

# Cluster 4 – free move

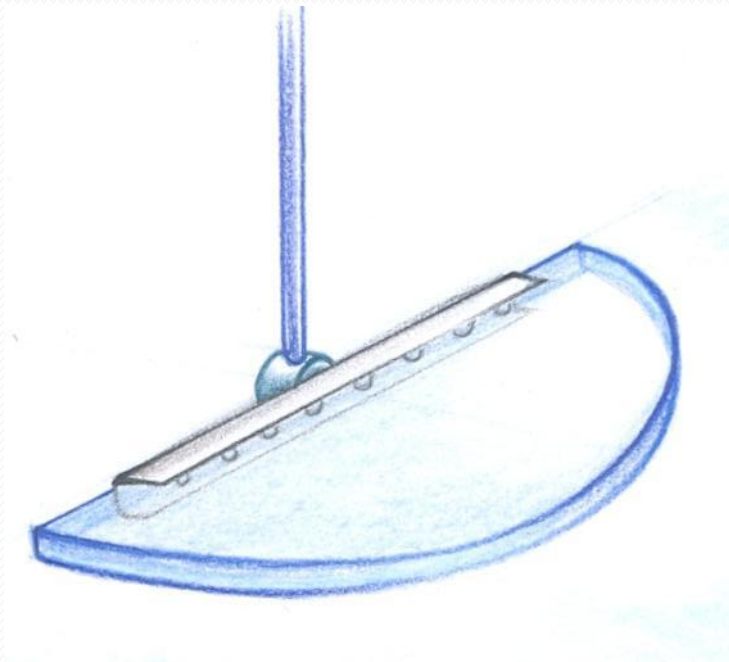

Acrylic plate & led's on edge

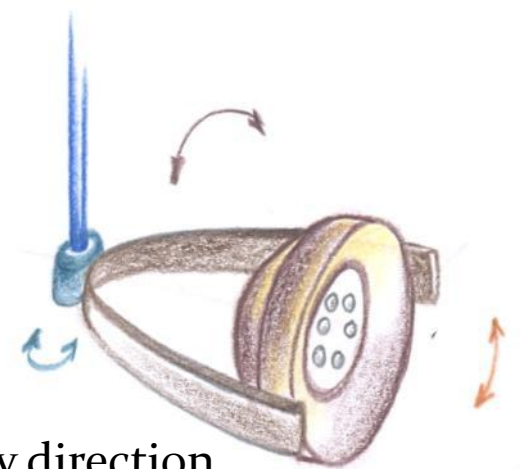
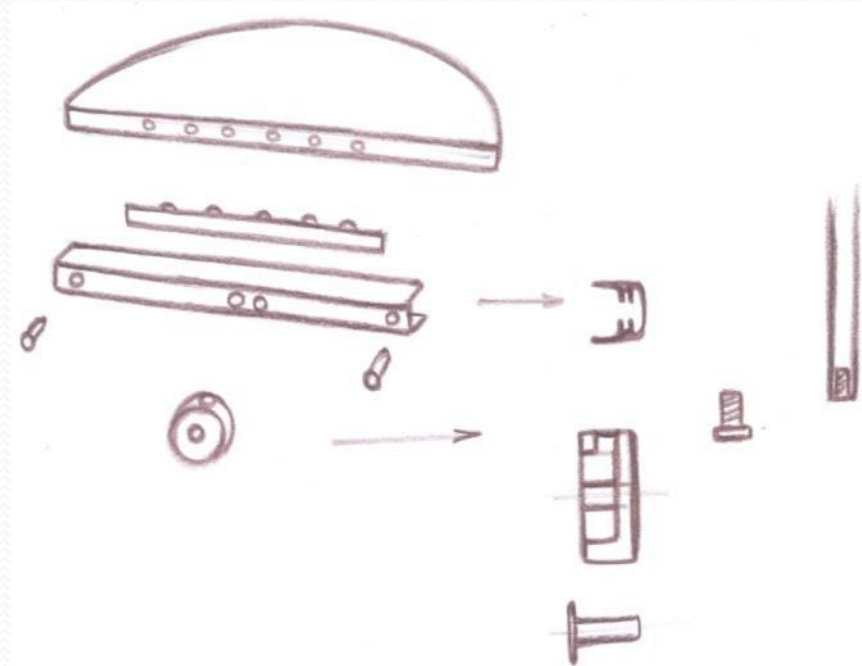

Movable in any direction

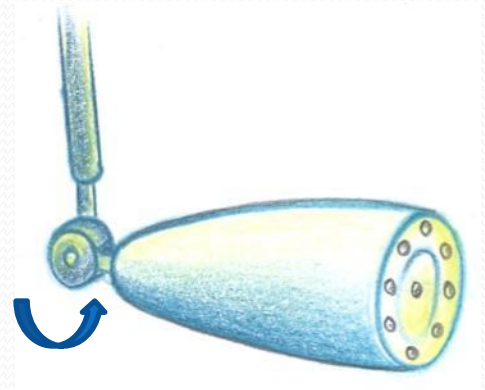
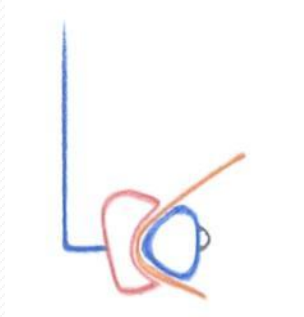
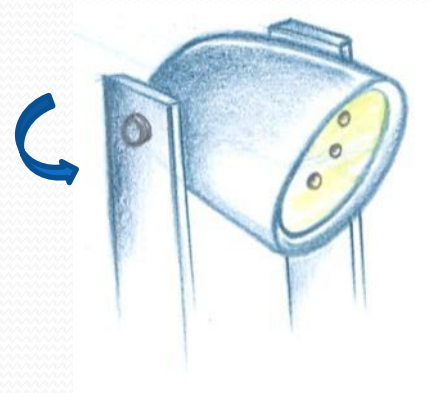
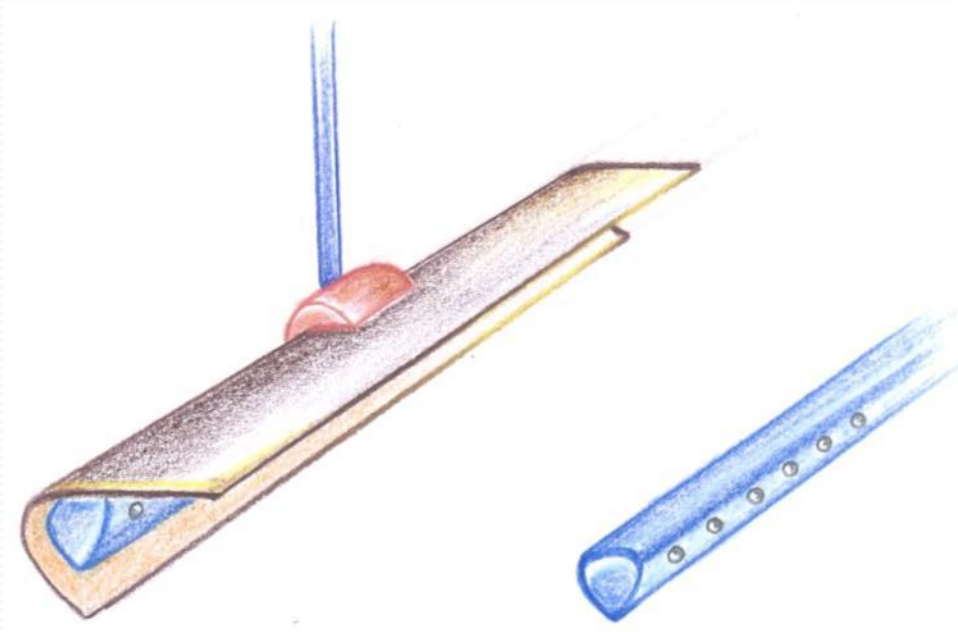

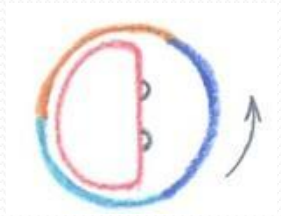
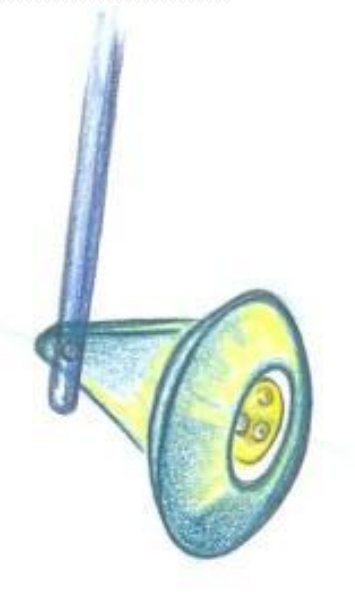
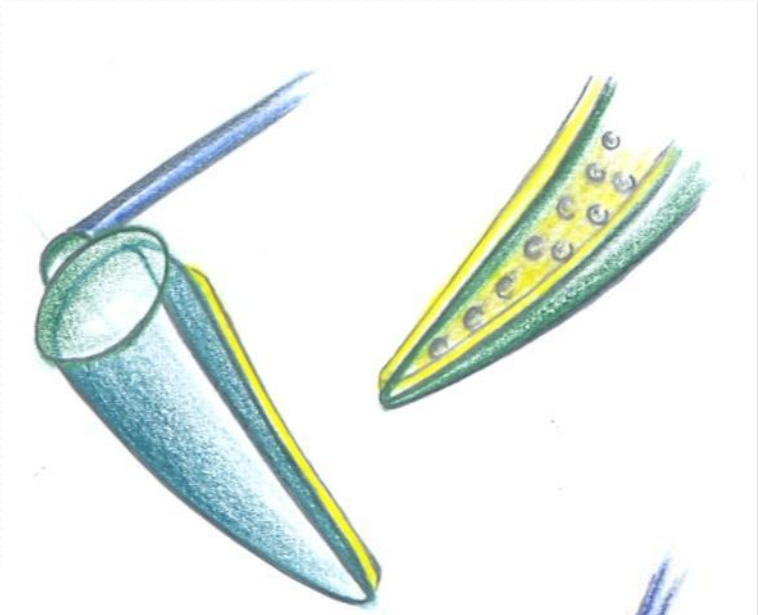

Three different shades

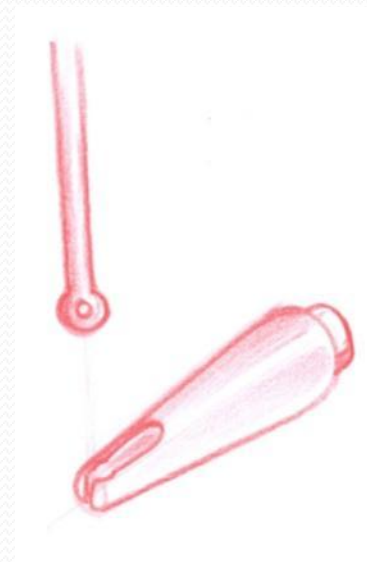
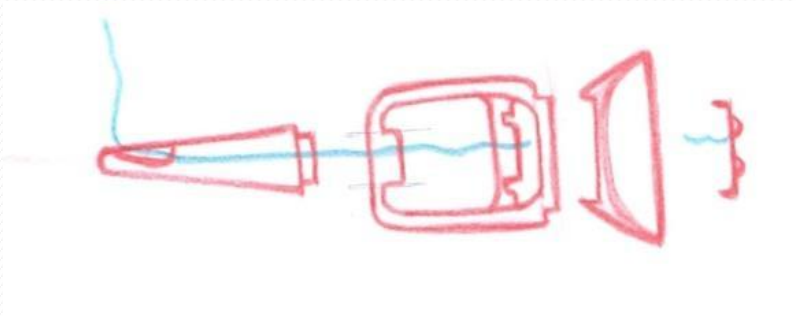
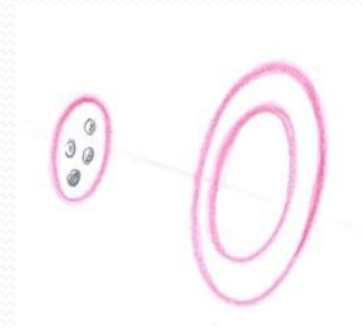
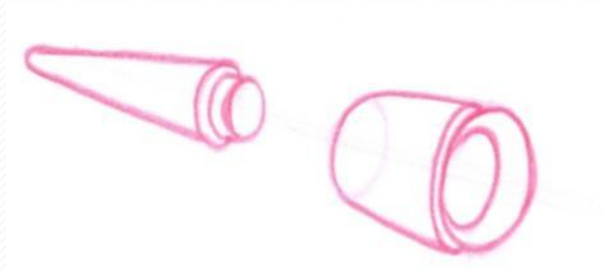
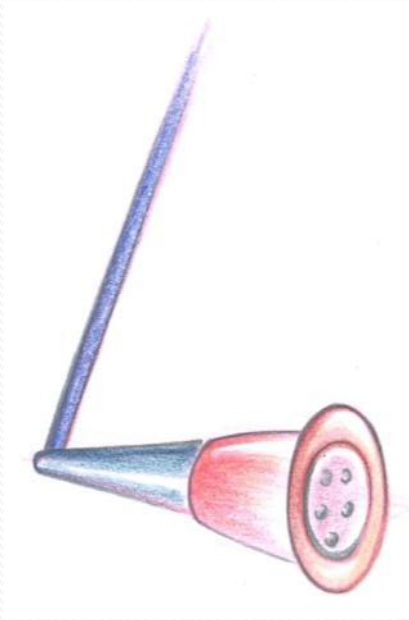

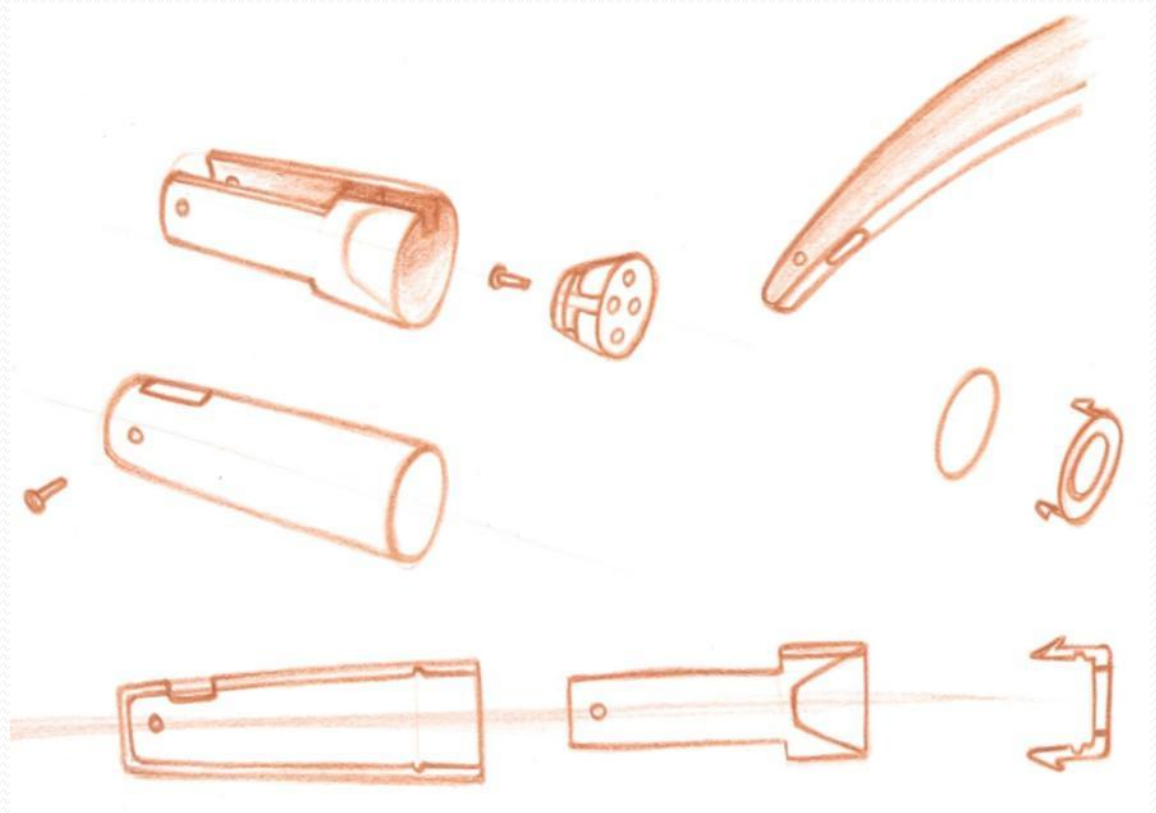
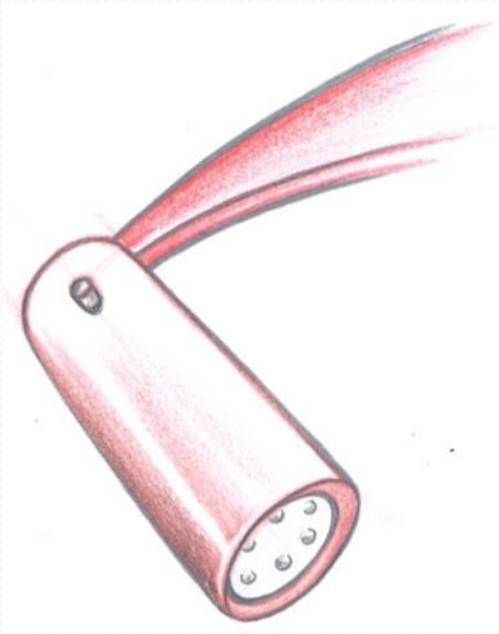



# Goose pipe for easy adjustment

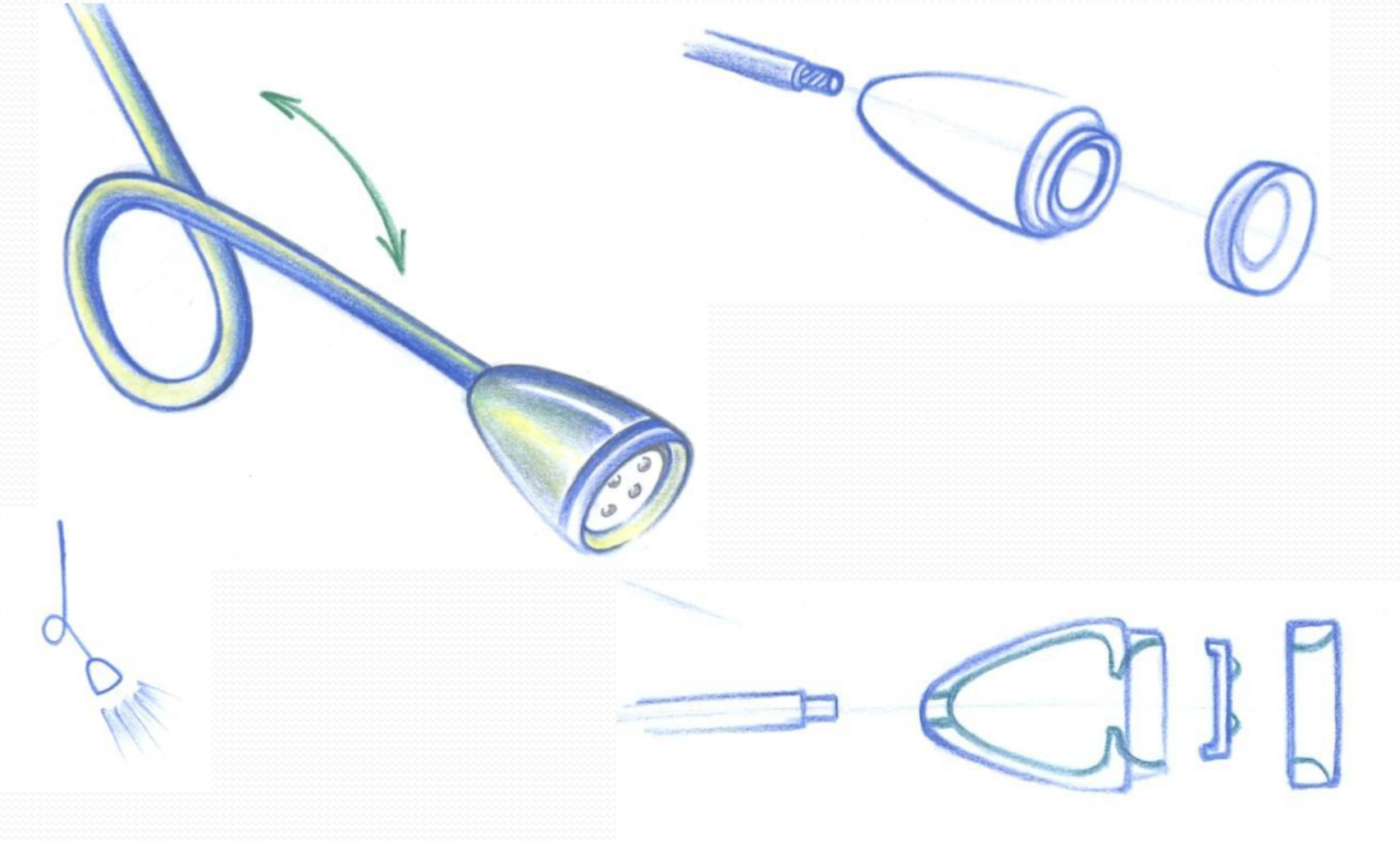

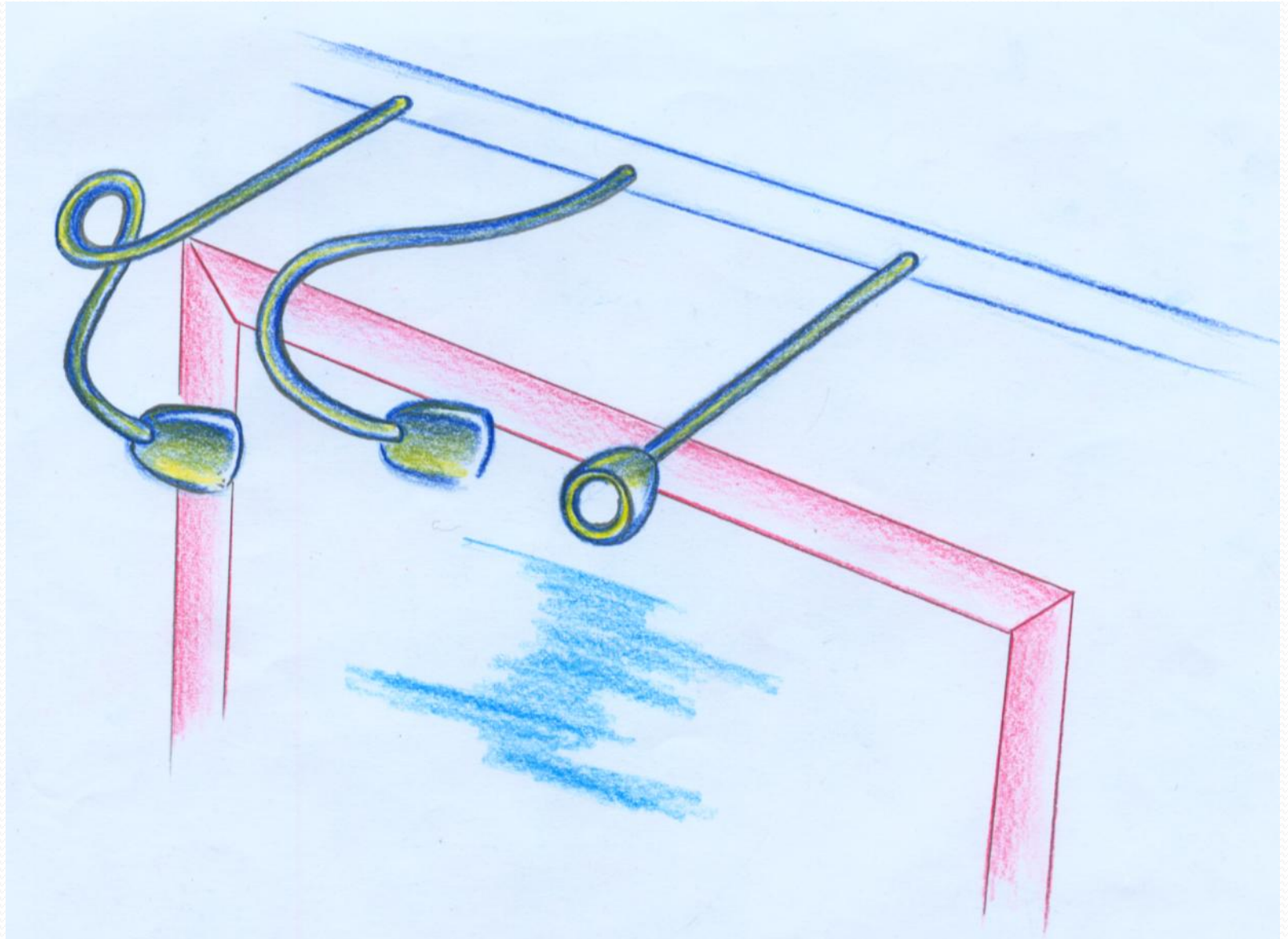

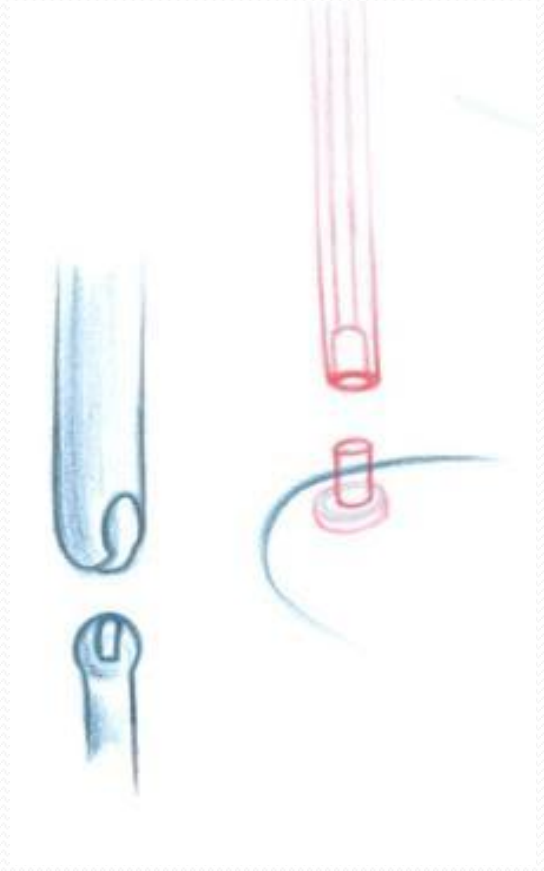
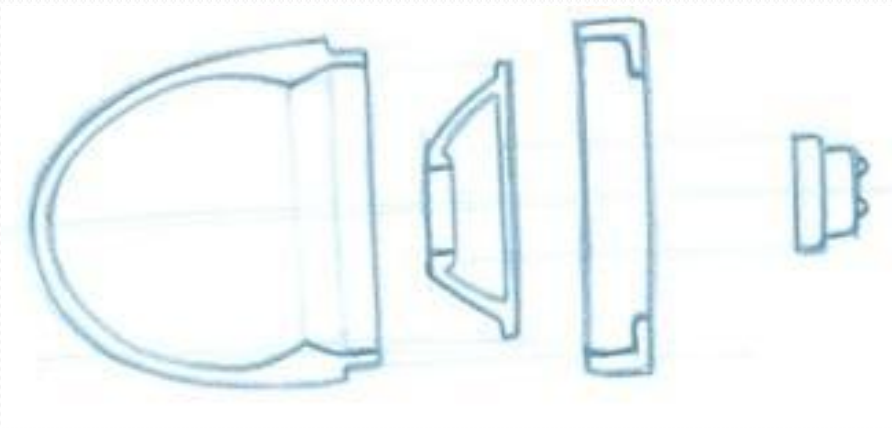

# Exploration

- Some ideas were tested to check their potential
- Different arrangements for position of track lights were tried out
- Different assembly possibilities...

# Acrylic in led

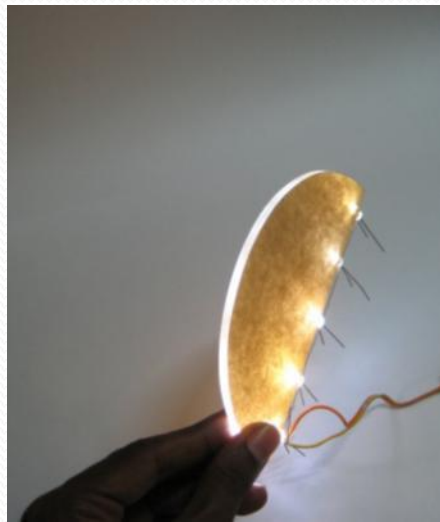

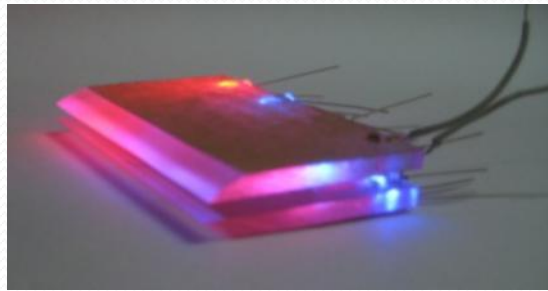
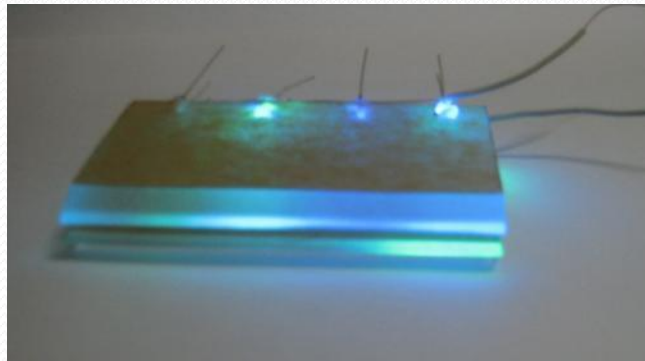
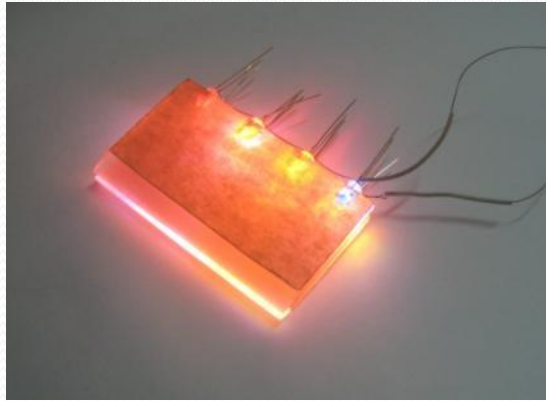

# Study of existing products







# Positioning of lights

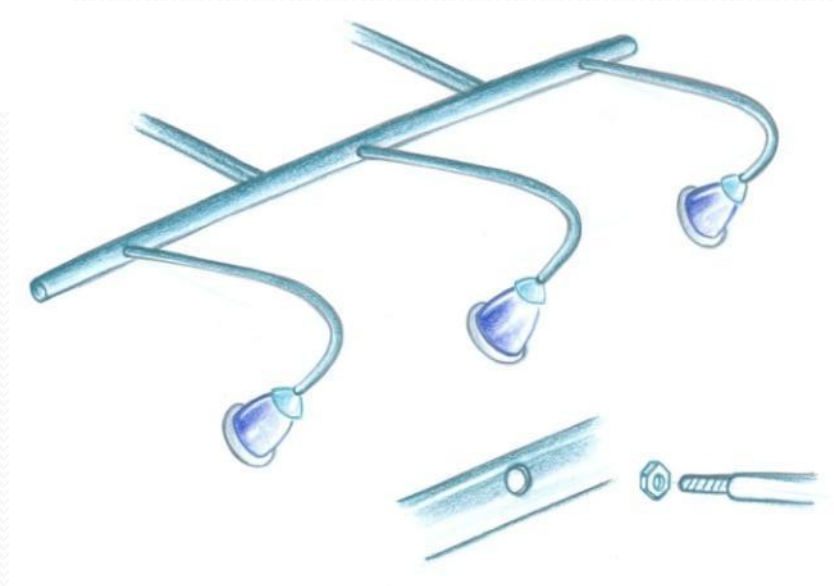
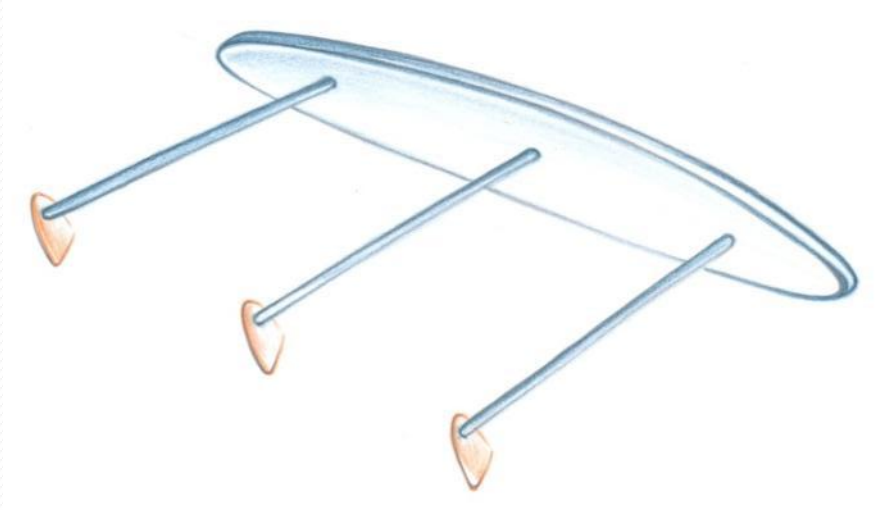

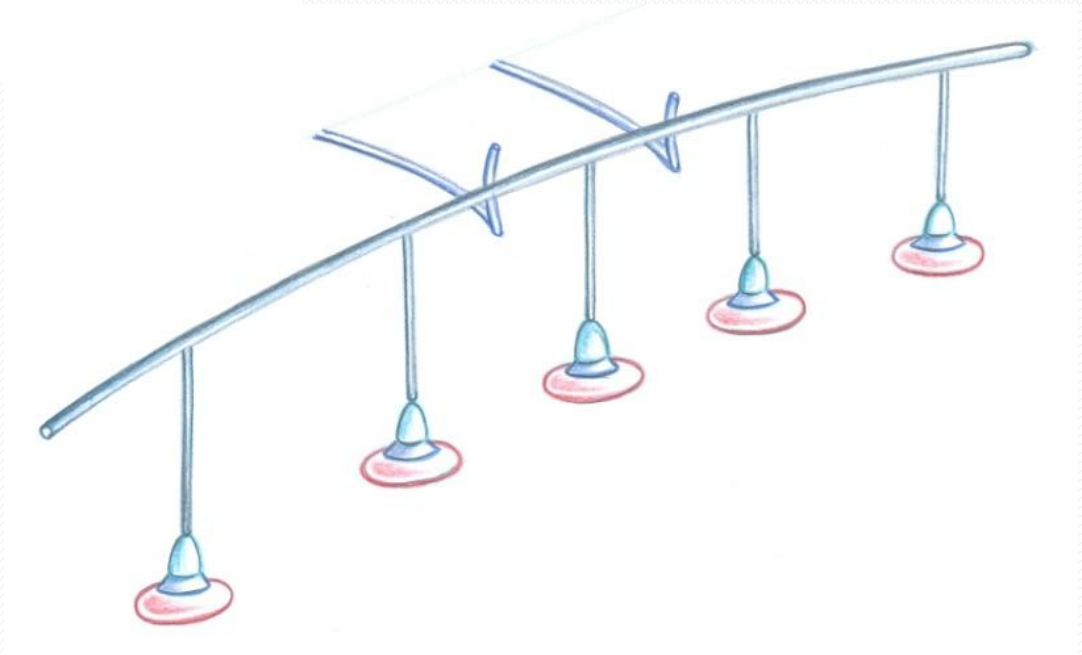
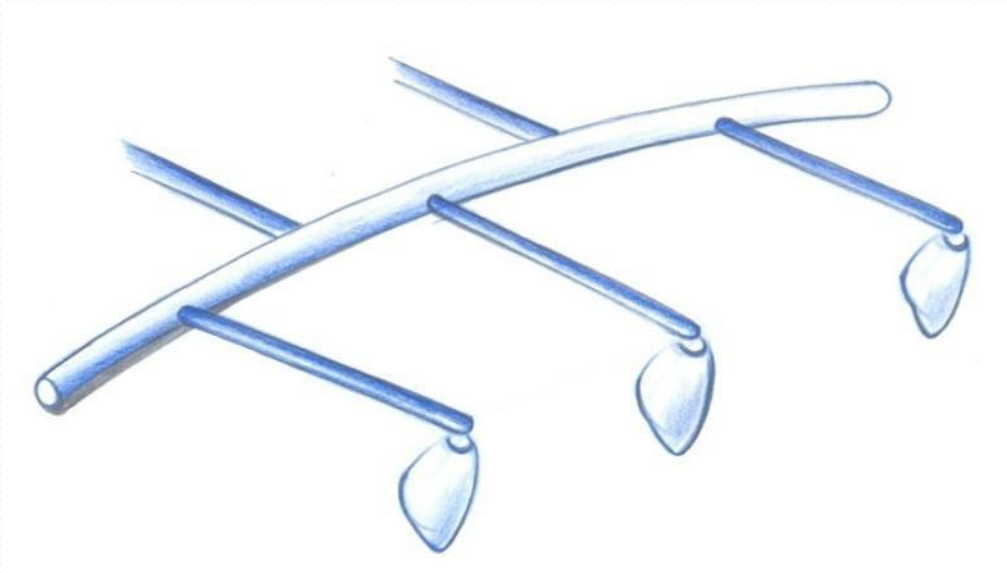

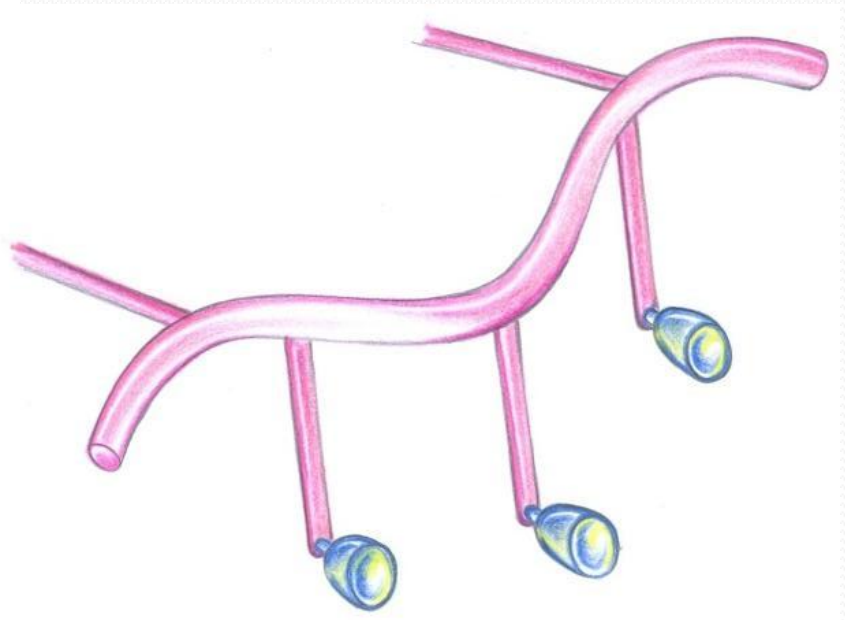
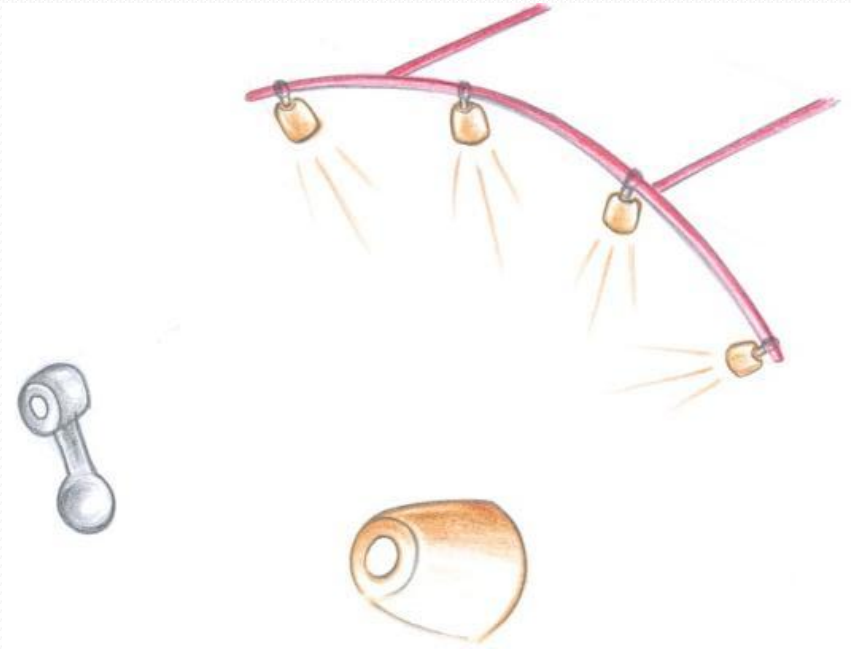

# Track light base Exploration

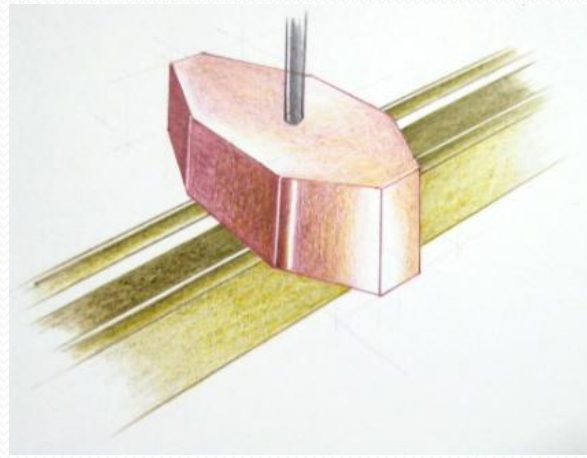
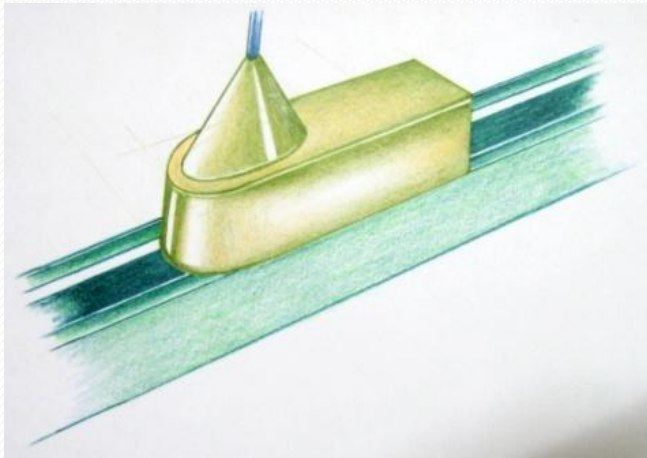
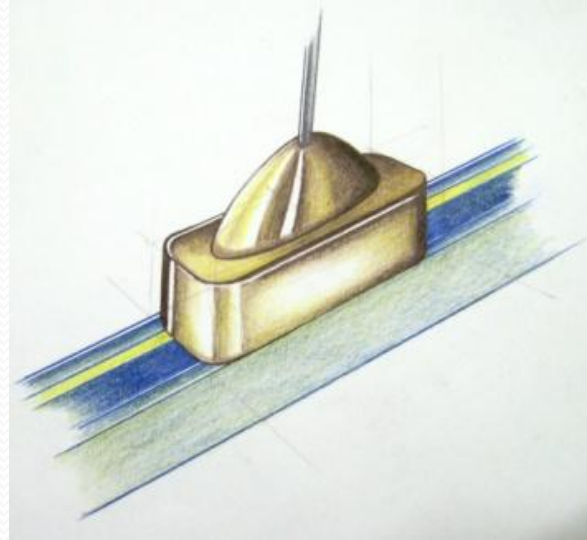
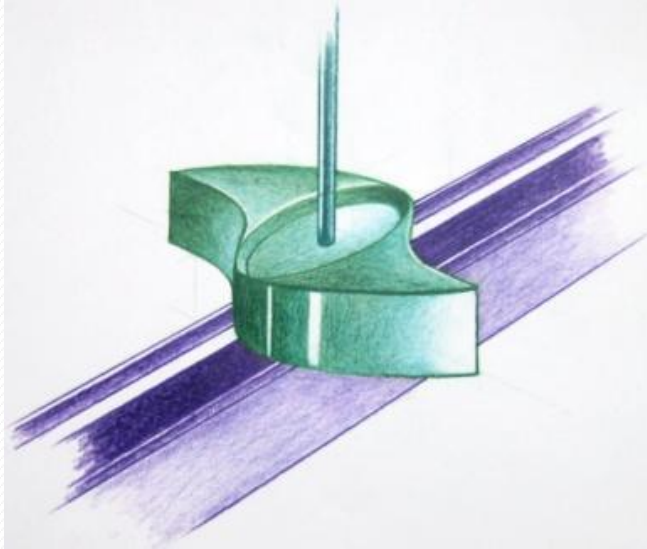

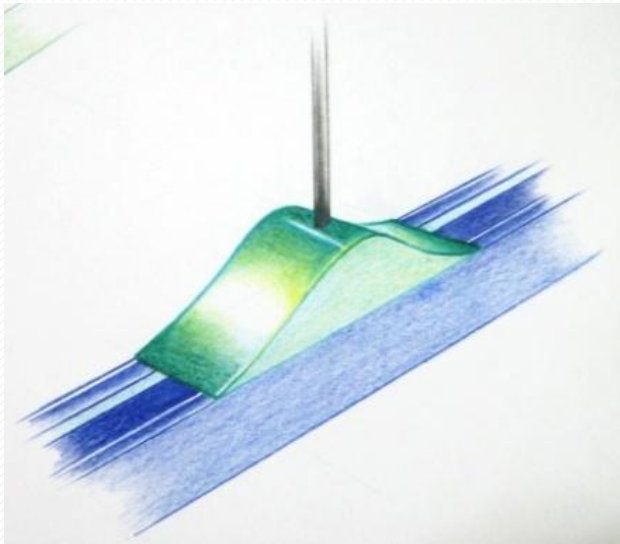
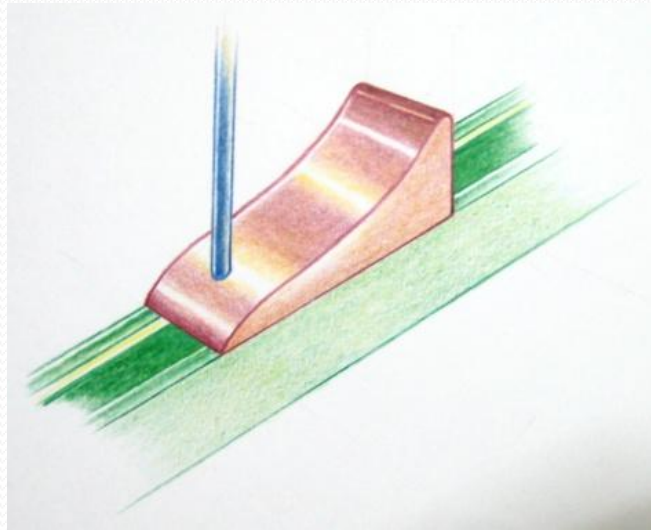
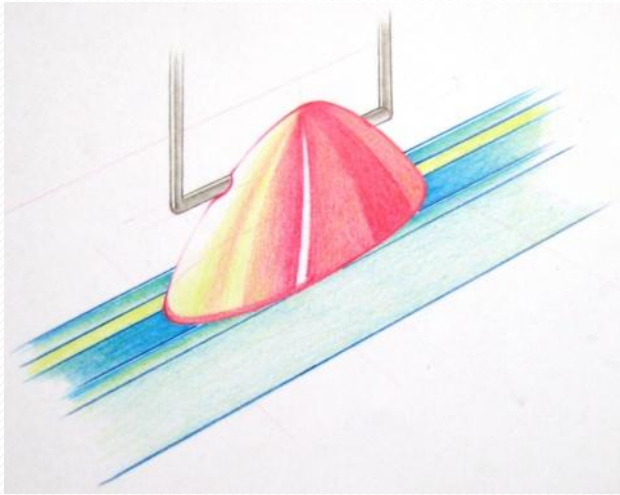

Light effects using two different colour led's are as follows:

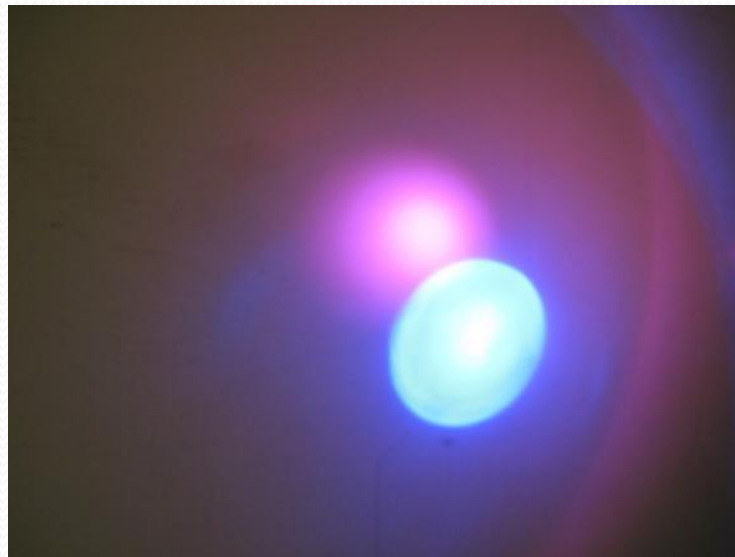
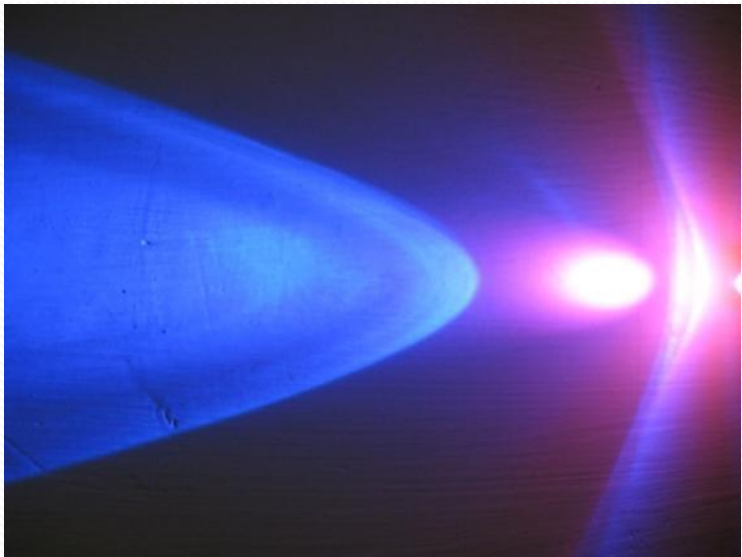
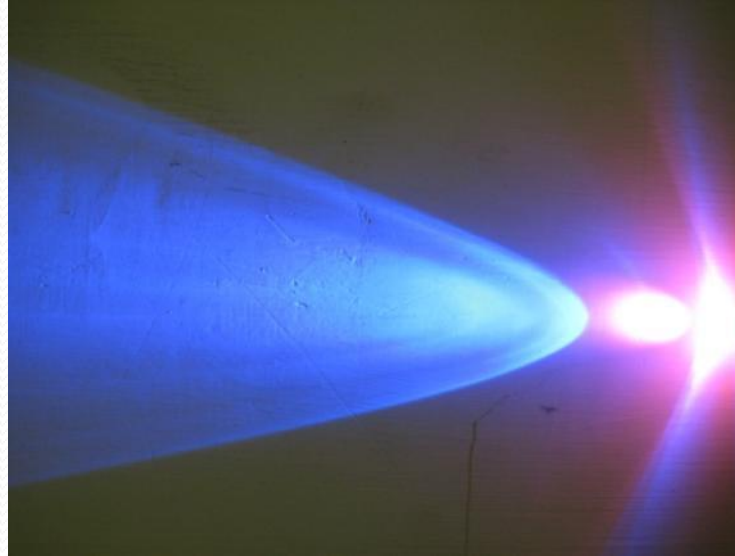
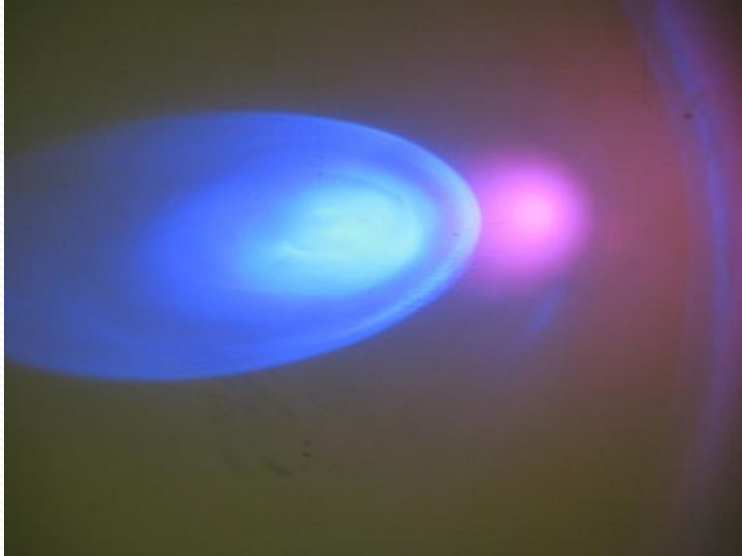

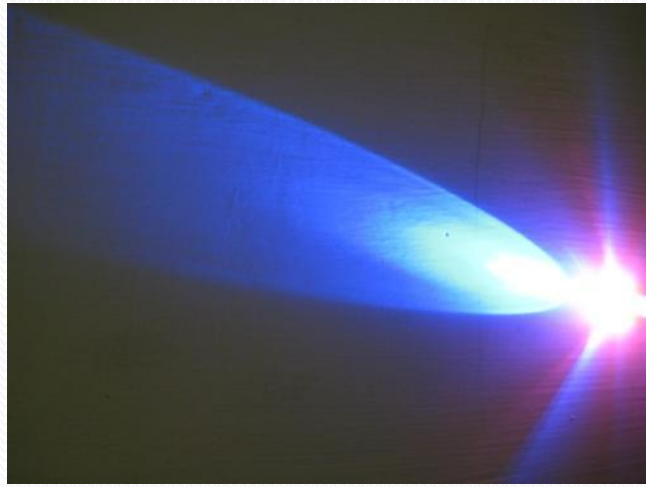
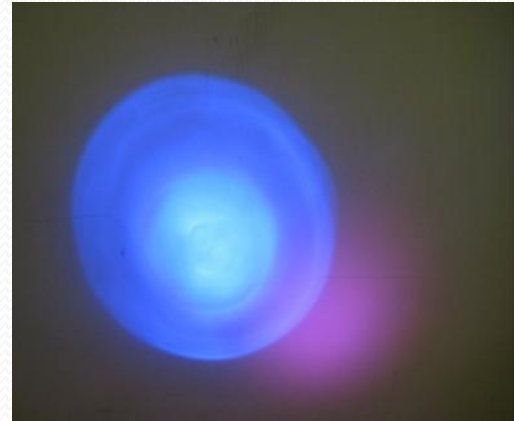
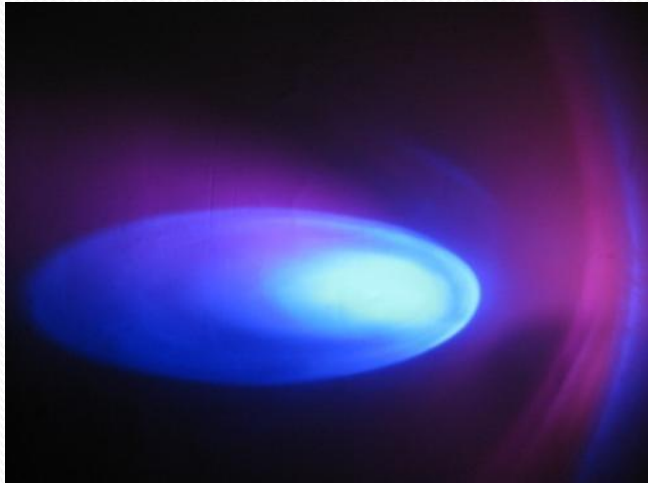

# Various light shades using Led in translucent paper:

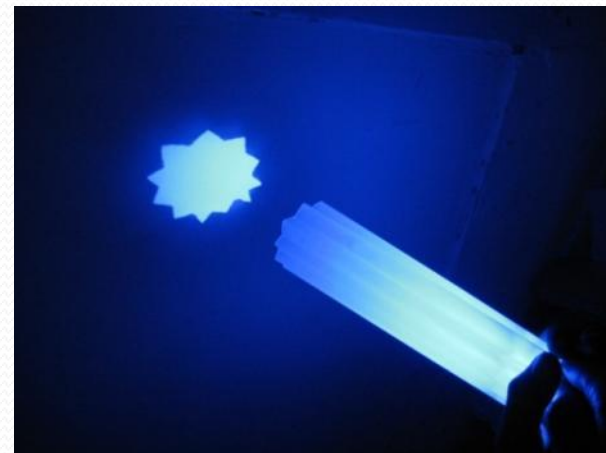



Various possibilities for acrylic rods are explored in wire, some of the pictures are as follows:

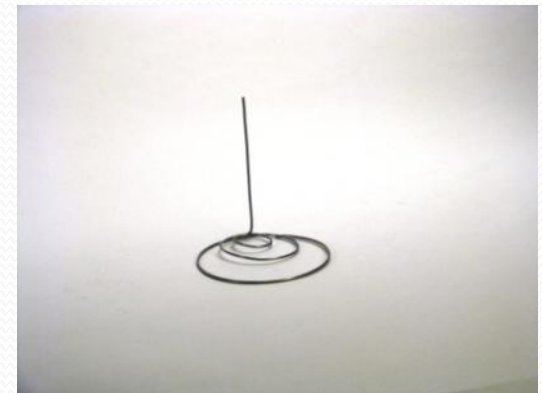
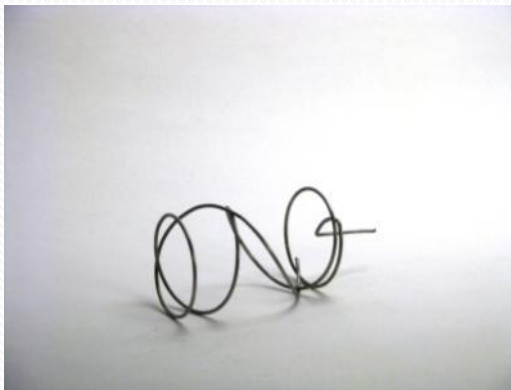
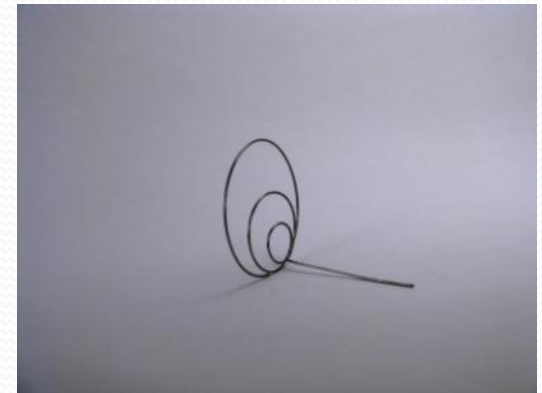
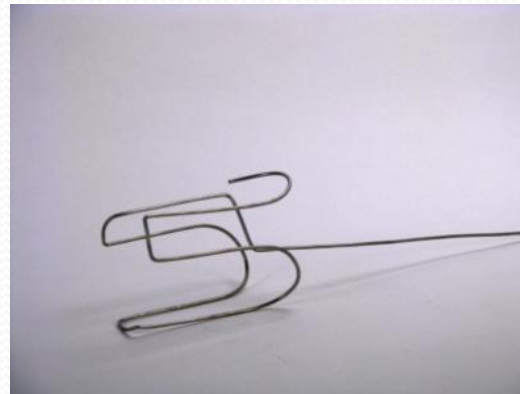

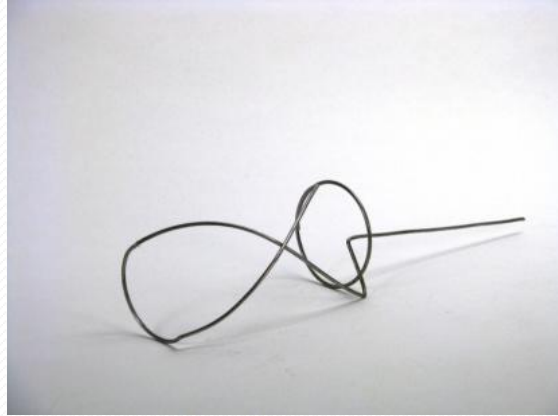
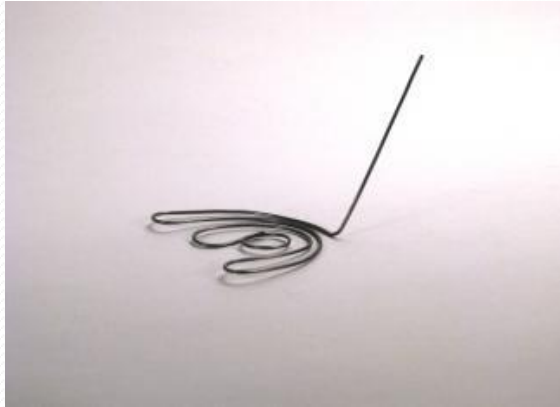

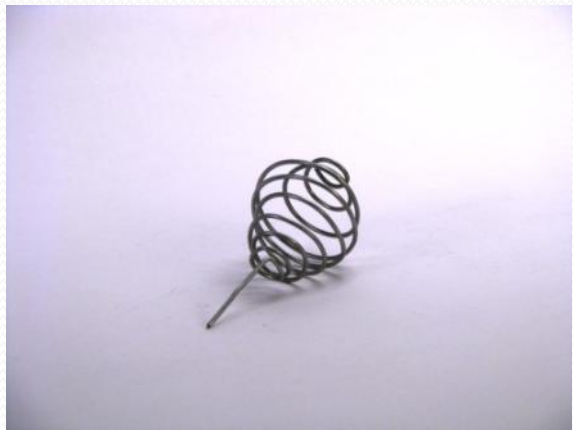
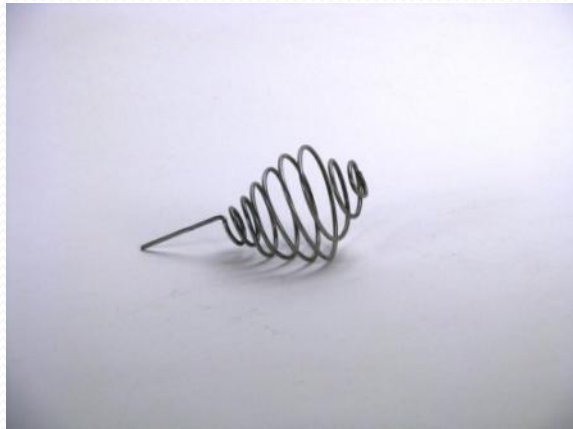

## Led and acrylic rods:

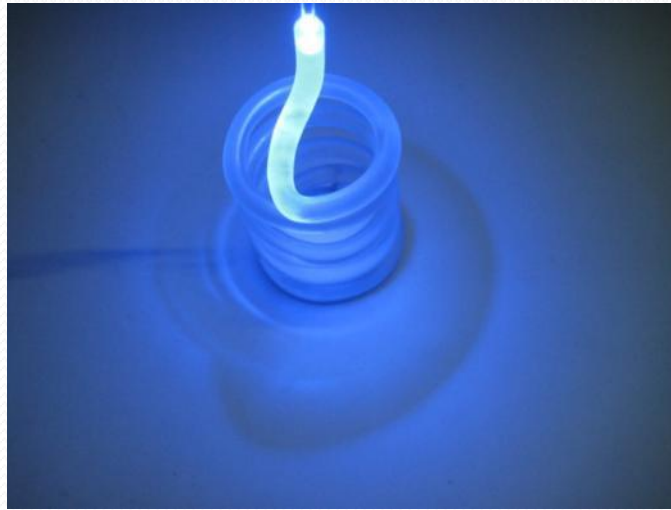

Effect of acrylic spiral light on the wall are as follows:

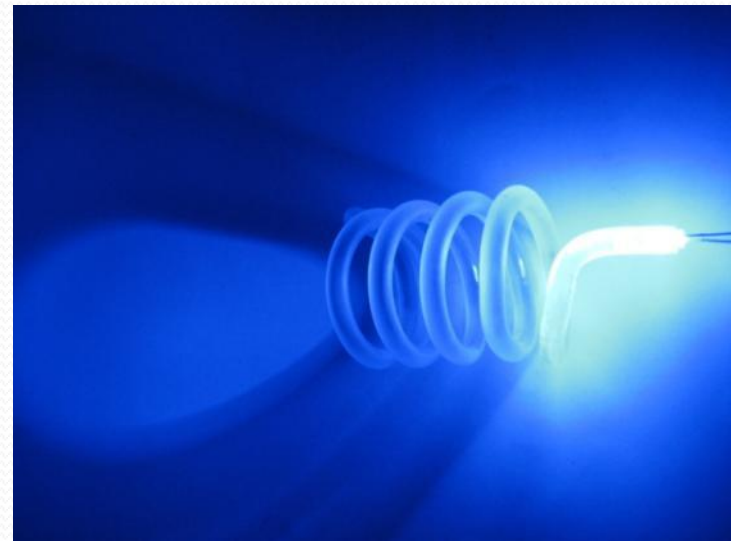
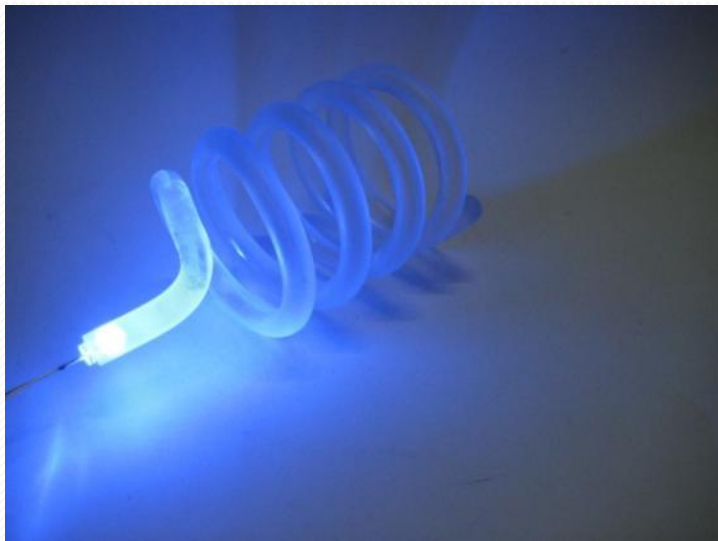
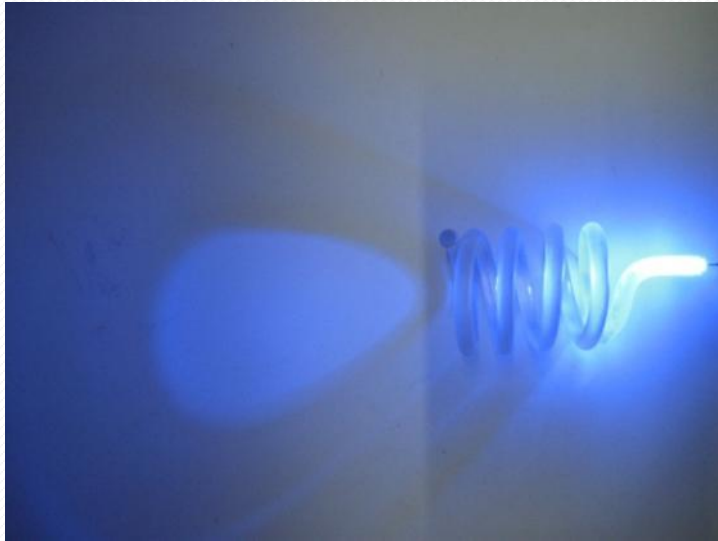

Led's inserted in formed acrylic sheet:

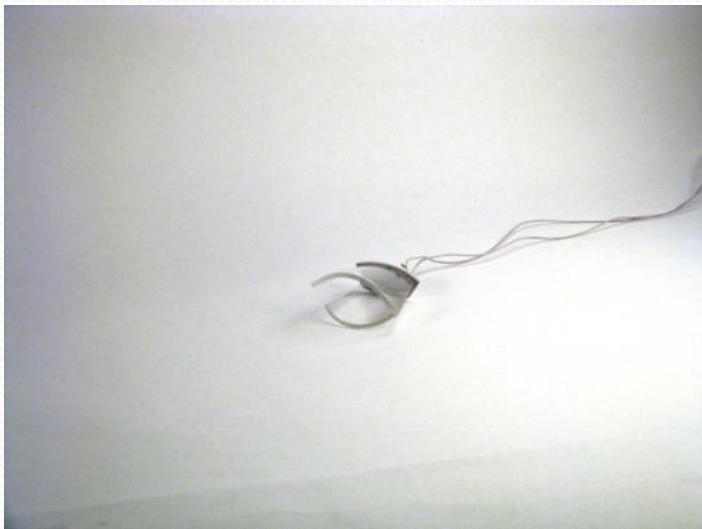
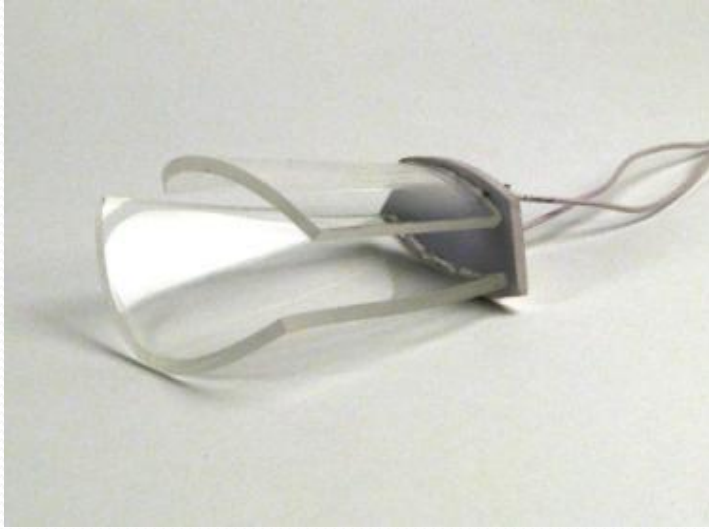

Curved Acrylic sheets placing one above the other:

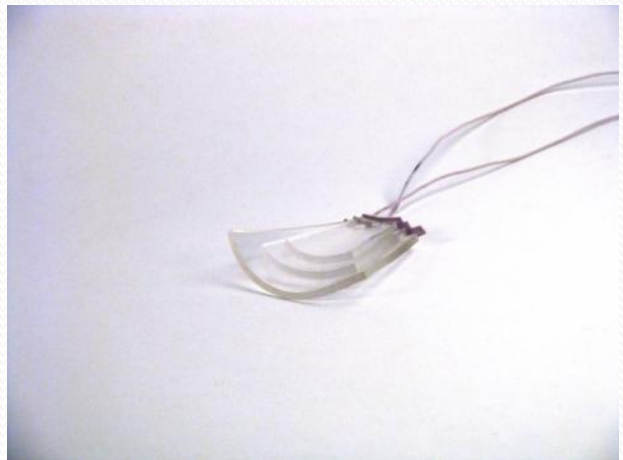
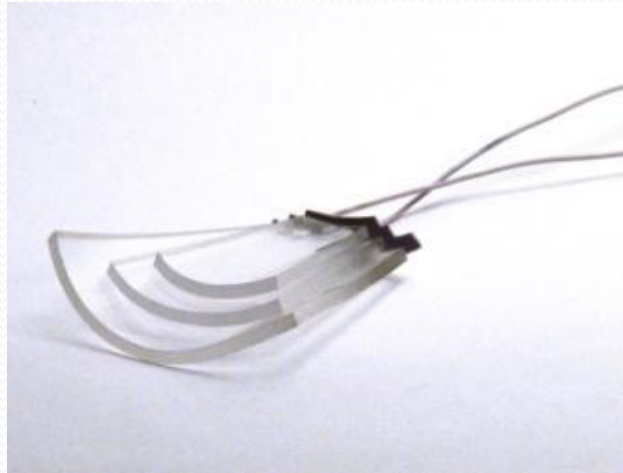

Acrylic bars fixed to circular base with led inserted in it:







Light with a profile cut, effect of translucent paper and led:



Light hanging from wall, using acrylic plates and led's:

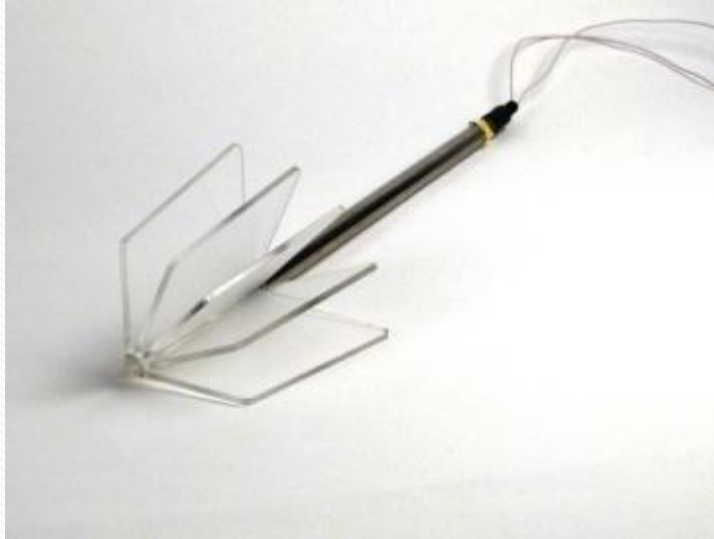



Translucent paper and led, hanging lights:

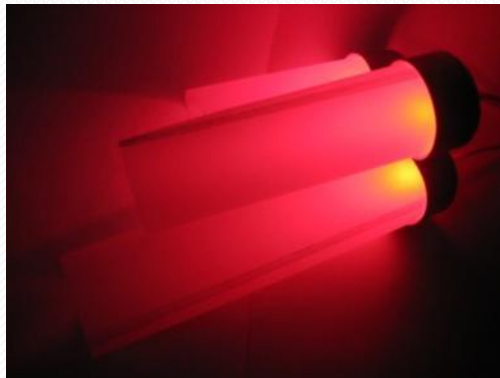
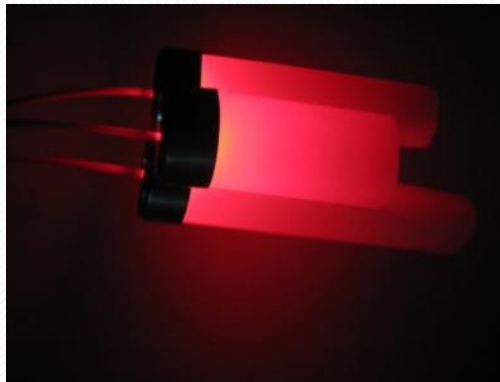
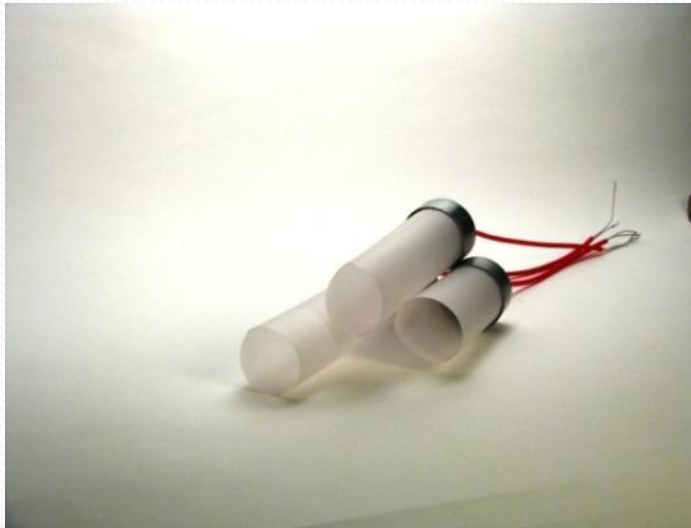
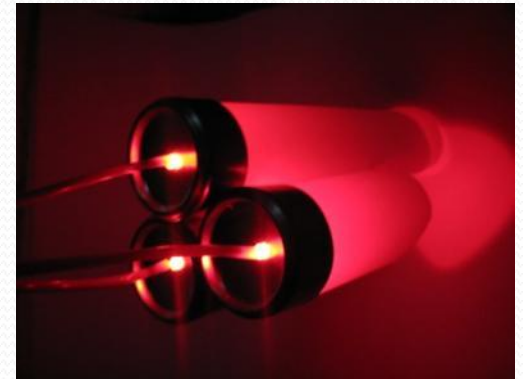
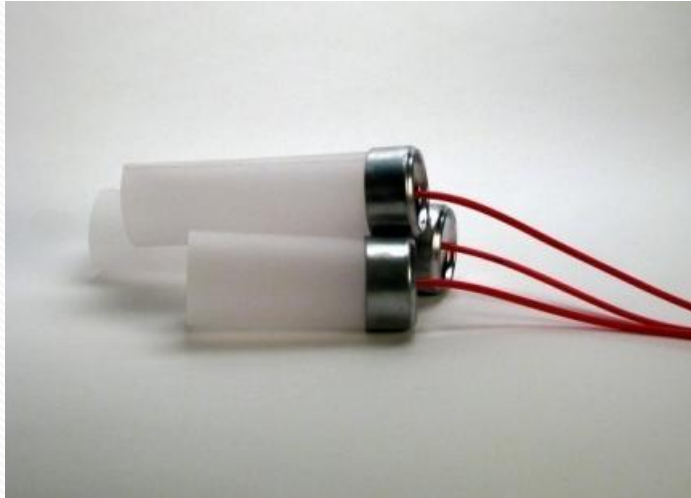

Light using single led, goose pipe for easy adjustment:



Various shapes from the same category which is shown above:



Translucent paper and led, holes are provided on circumference gives good effect:

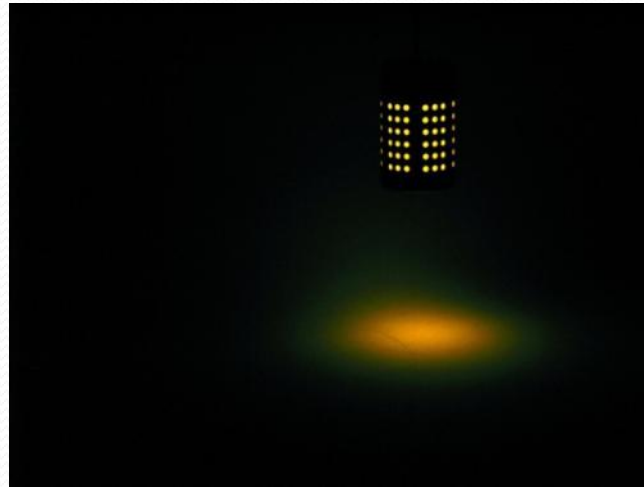
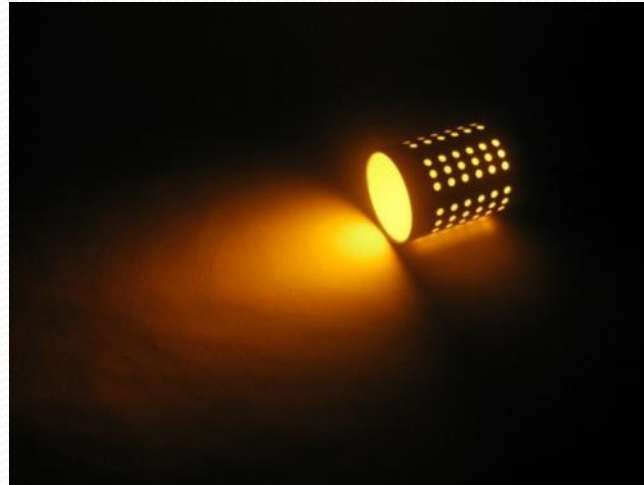



Light butterfly: Butterfly with light and a globe a butterflies as below:

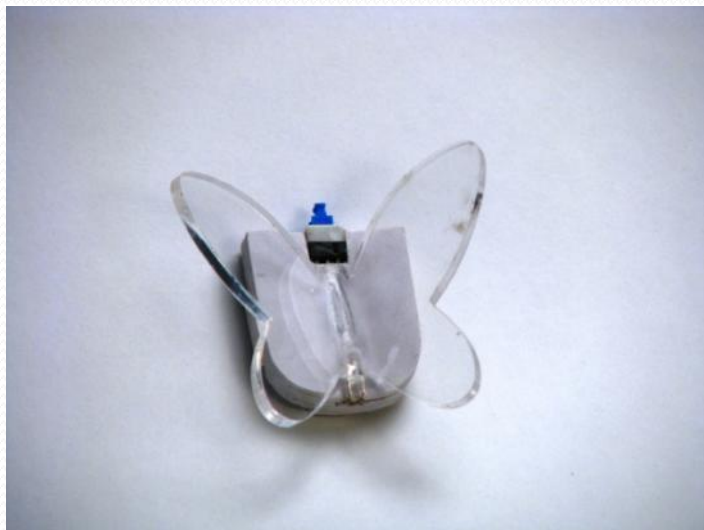

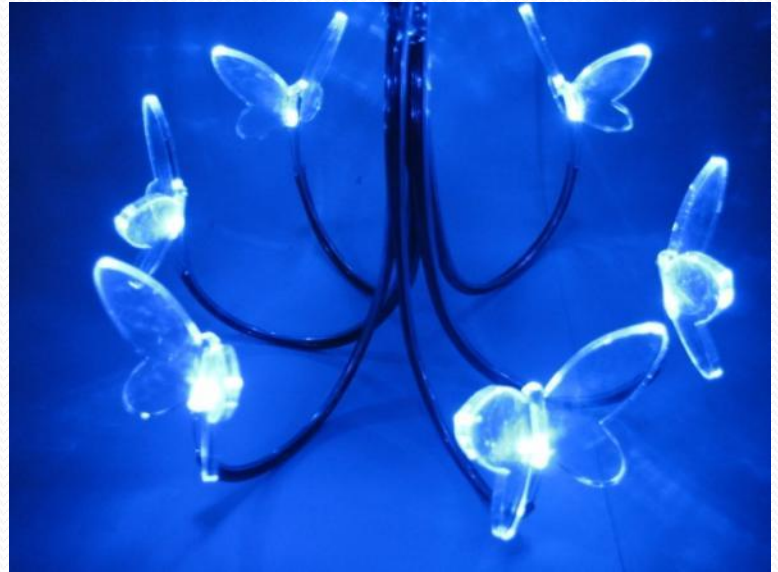

Tried out butterfly in other form with itching, gives good effect. In this case the battery casing is kept vertical to the wall. And considering butterfly as a single element various pattern can be created on the wall as below:



# Concept 1-A

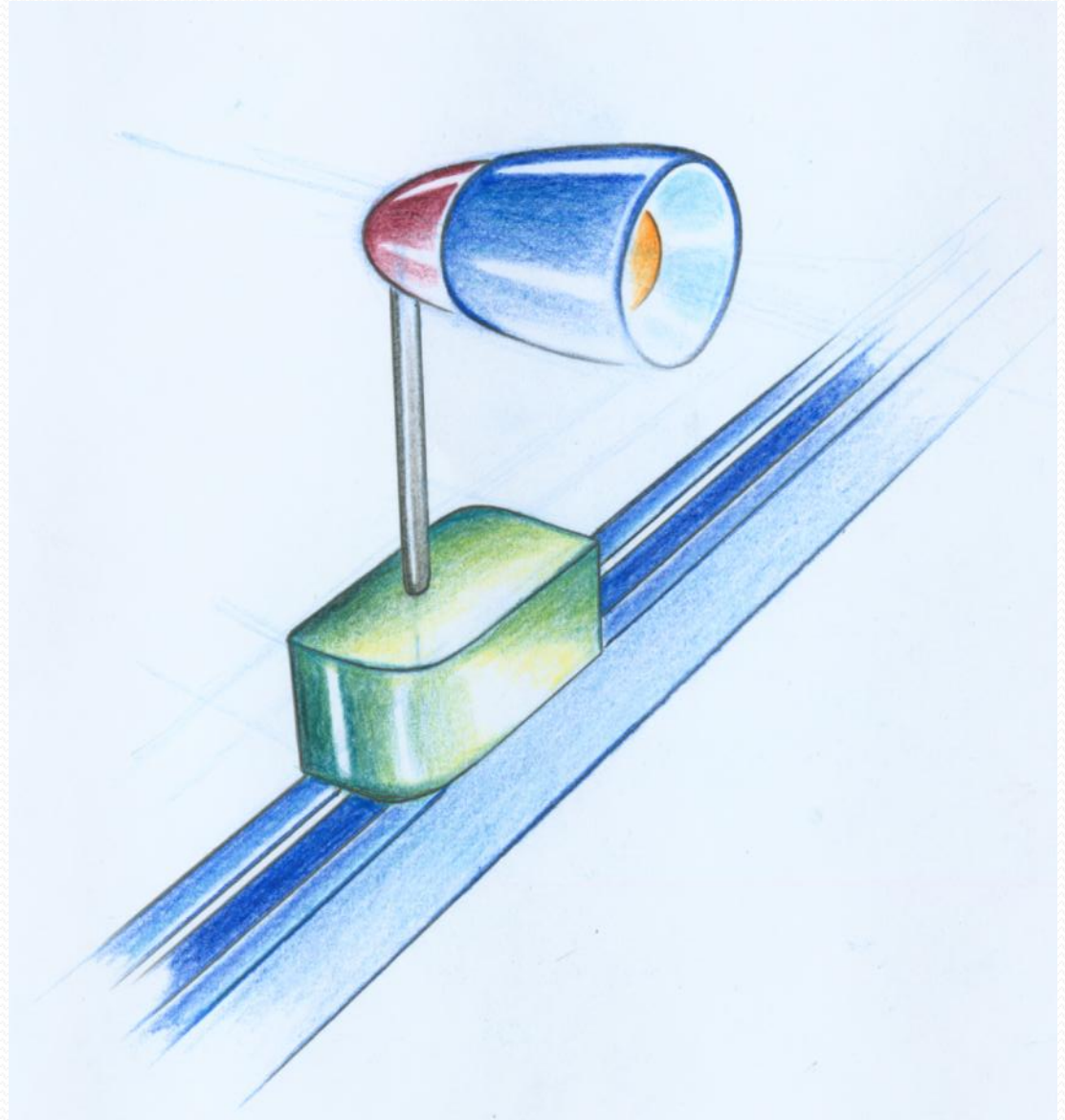

# Concept 1-B

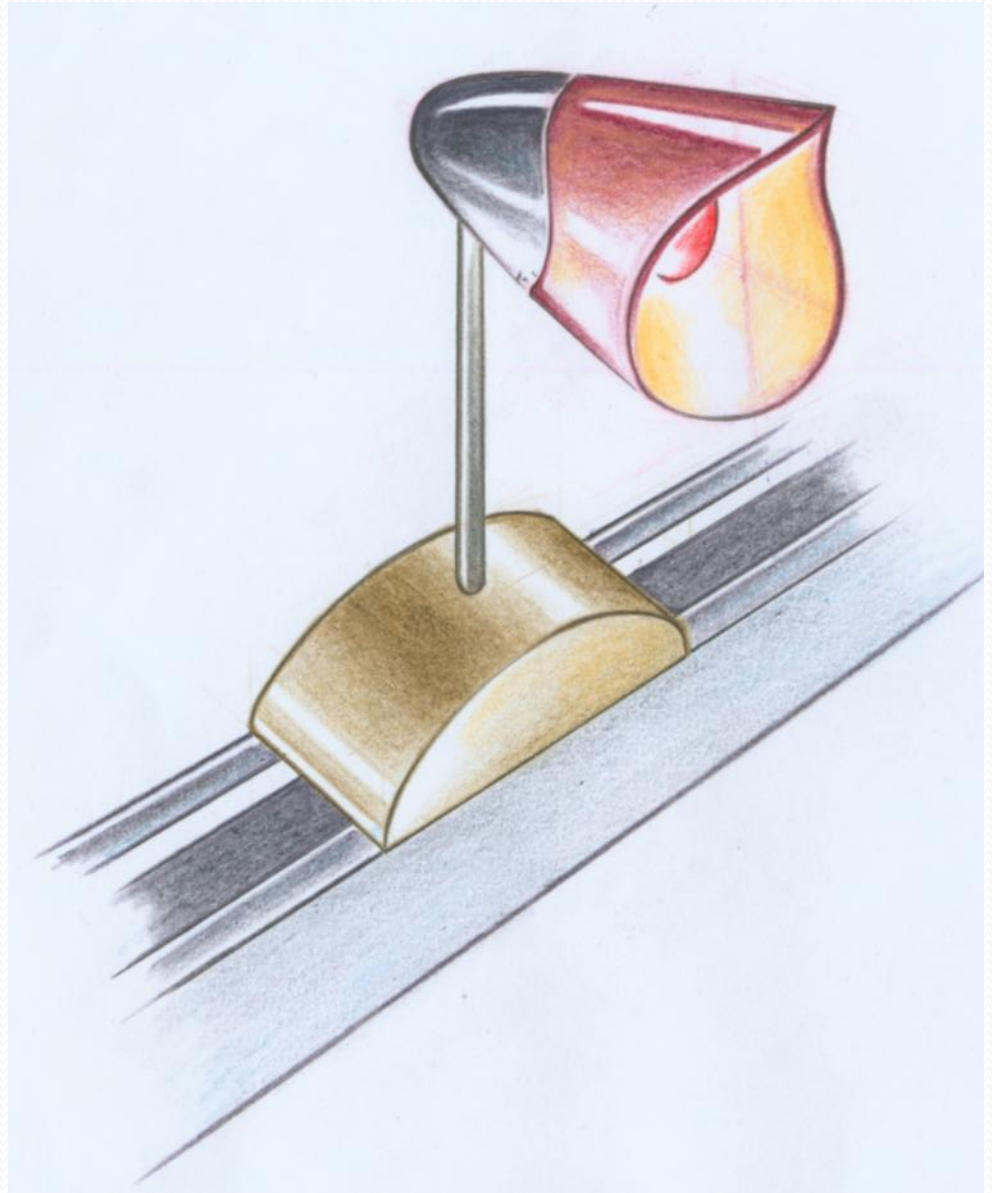

# Concept 1-C

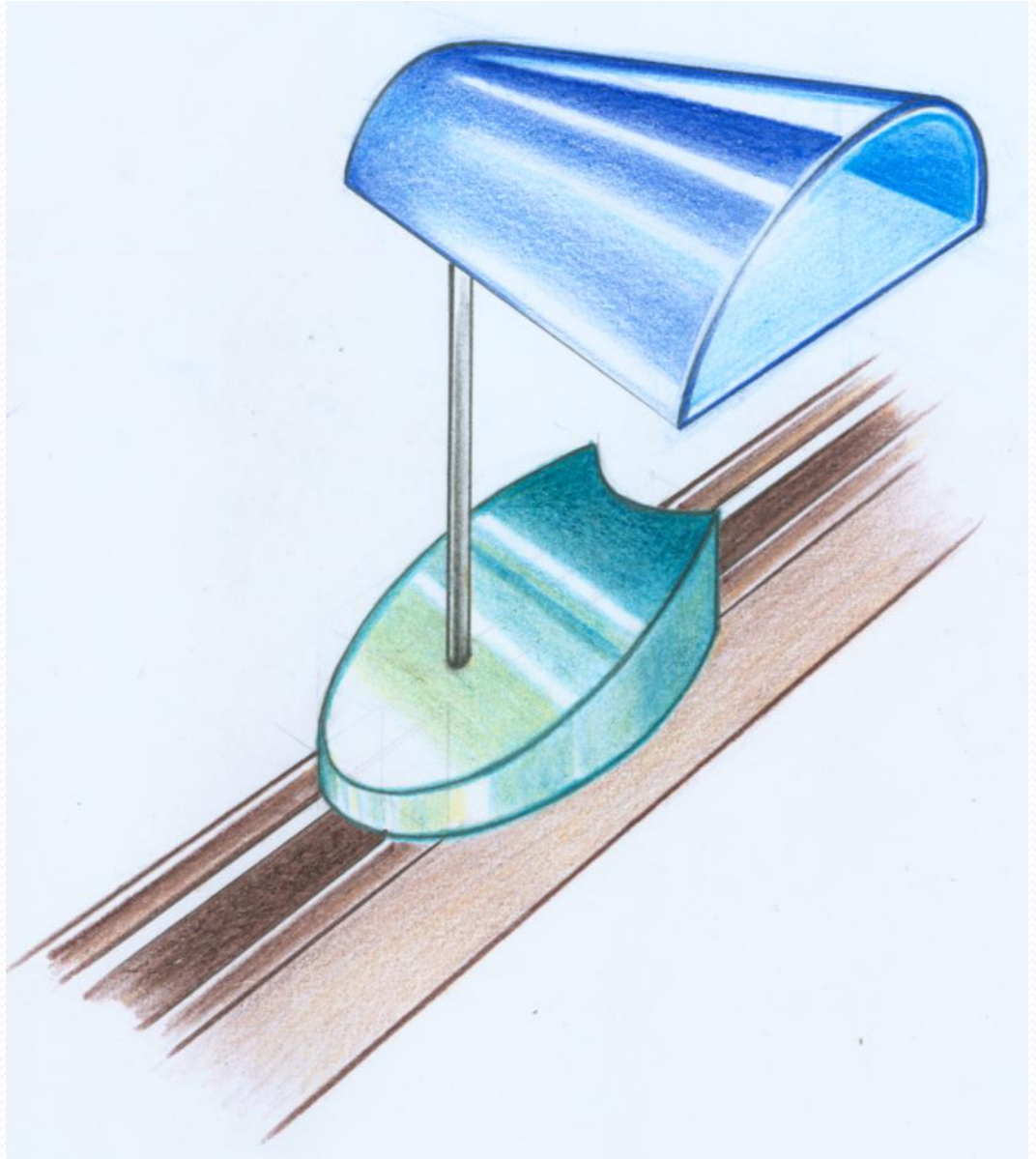

# Concept 2-A

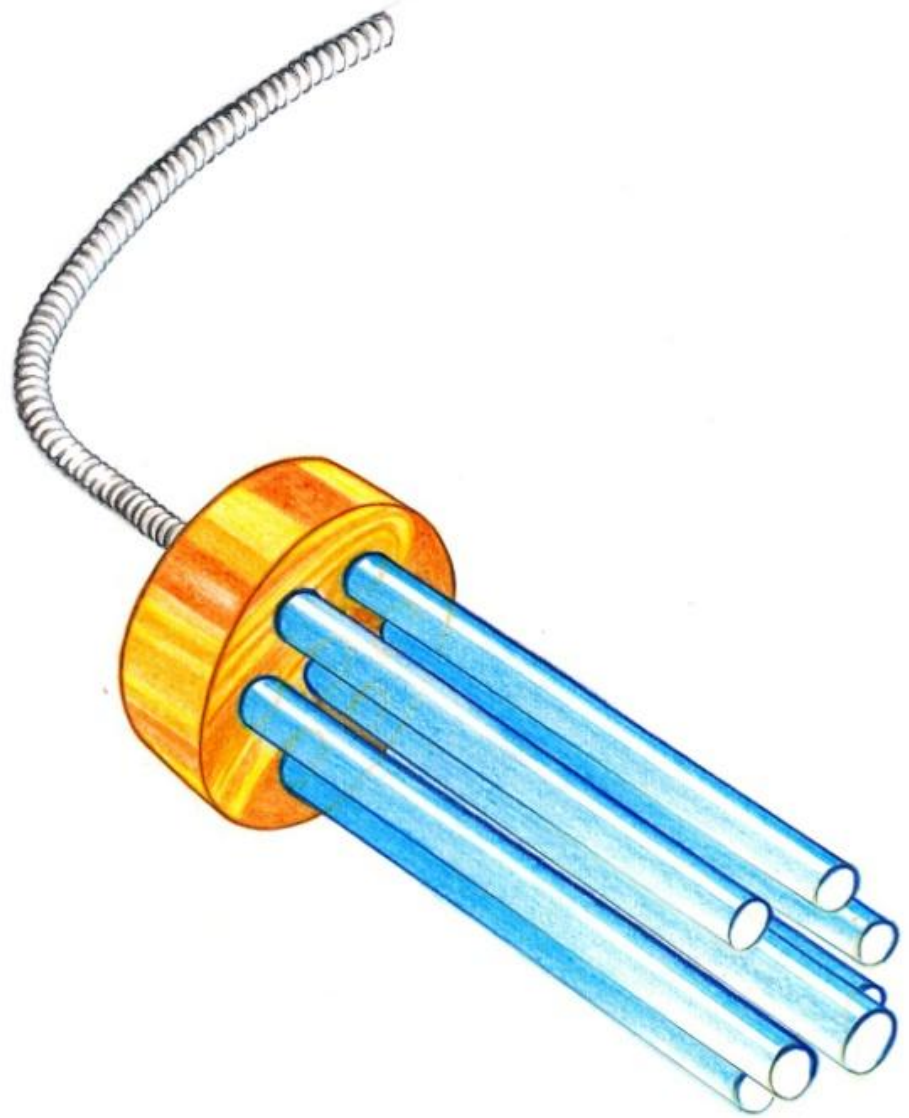

# Concept 2-B

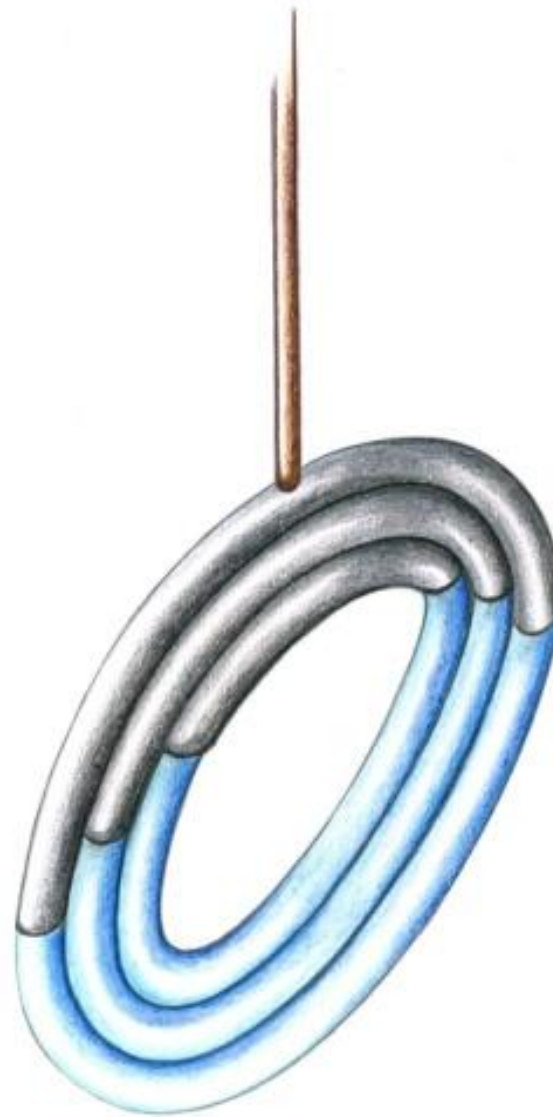



# Concept 2-C

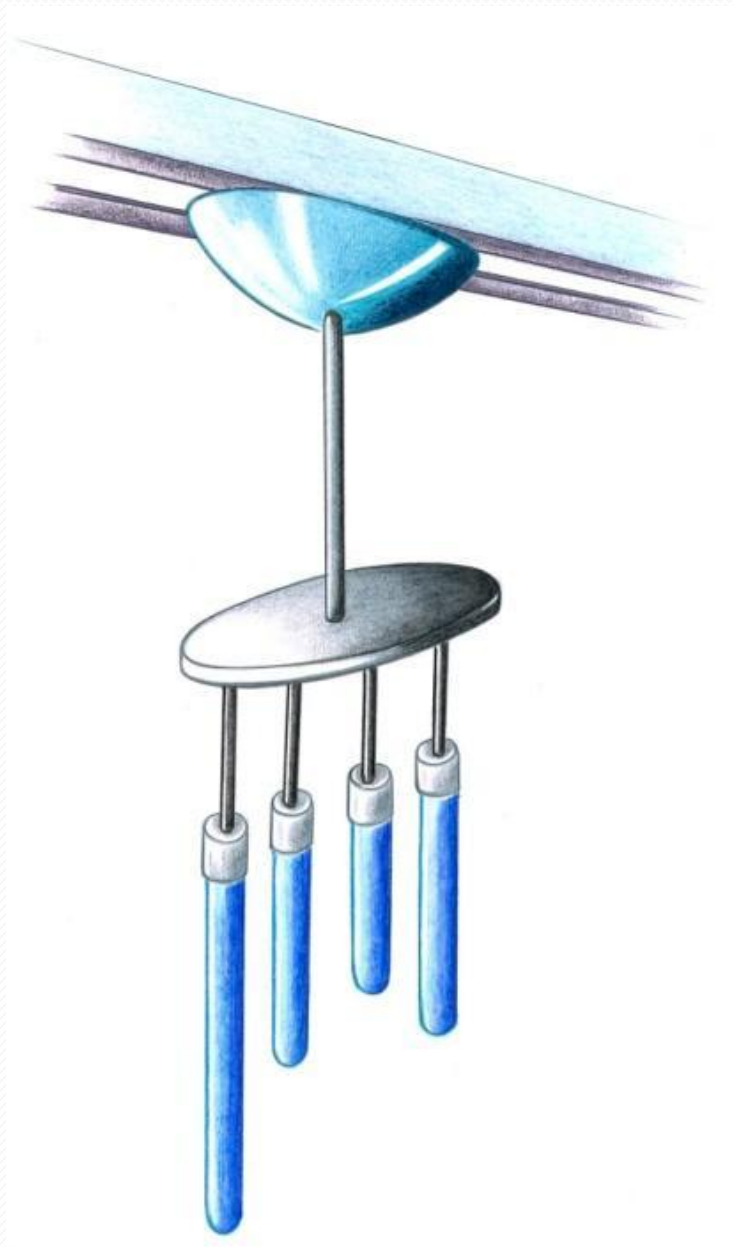

# Acrylic rods and led's, track light for ceiling:

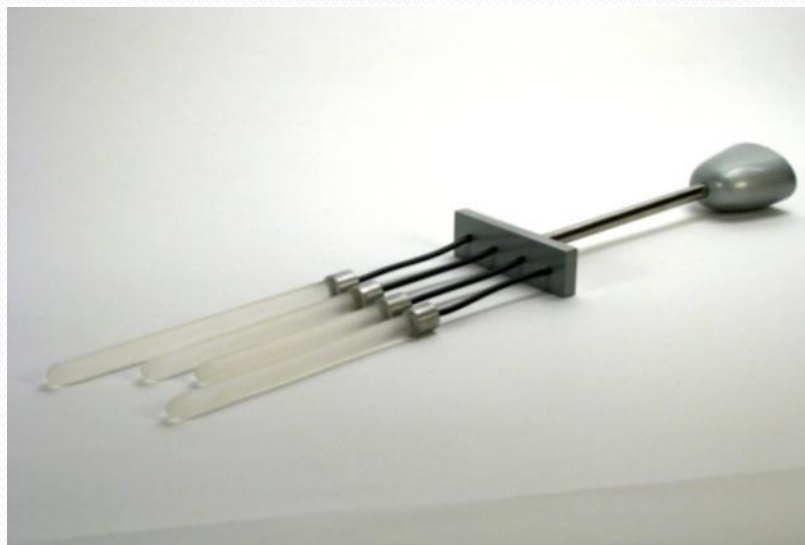

# Concept 3



Spiral acrylic rod and single led, track light can be mounted on ceiling or wall:

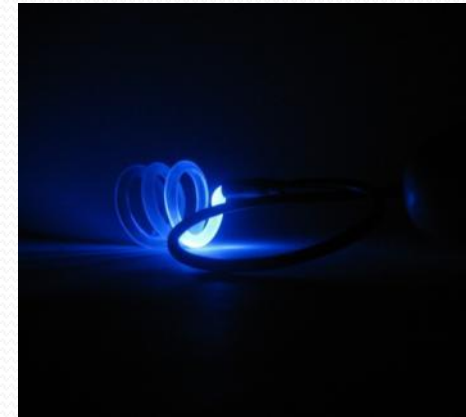

# Concept 4

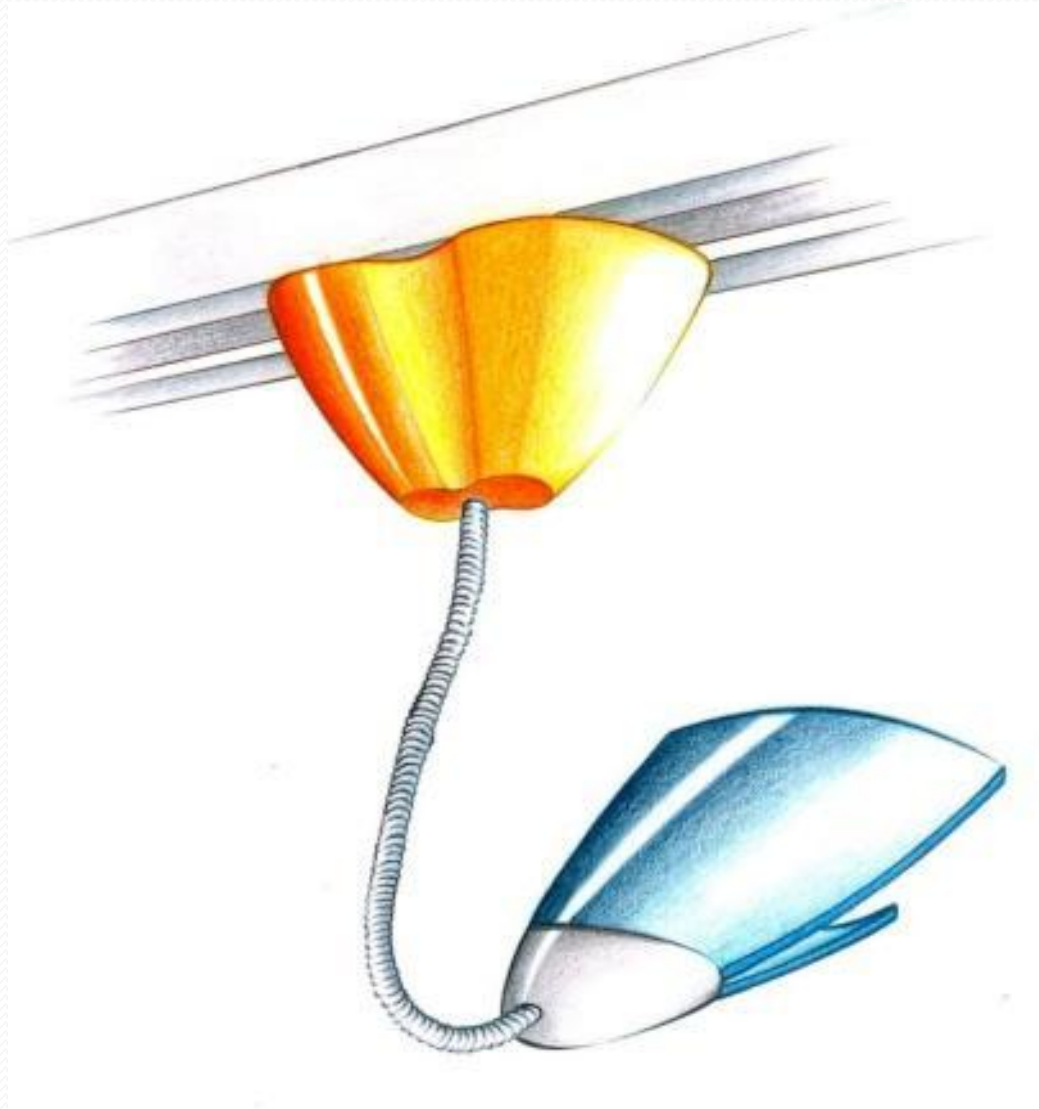

Formed acrylic sheets and RGB controlled led's, track light which can be fixed on a track on wall:



Various colour possibilities in a single light....

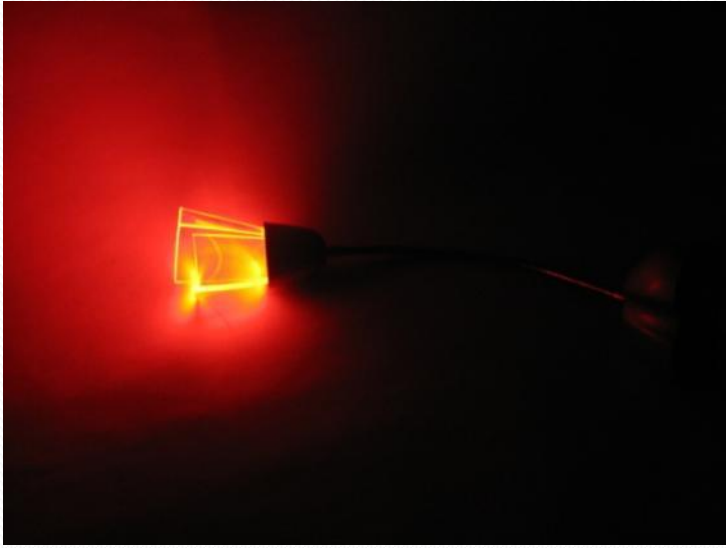

# Concept 5

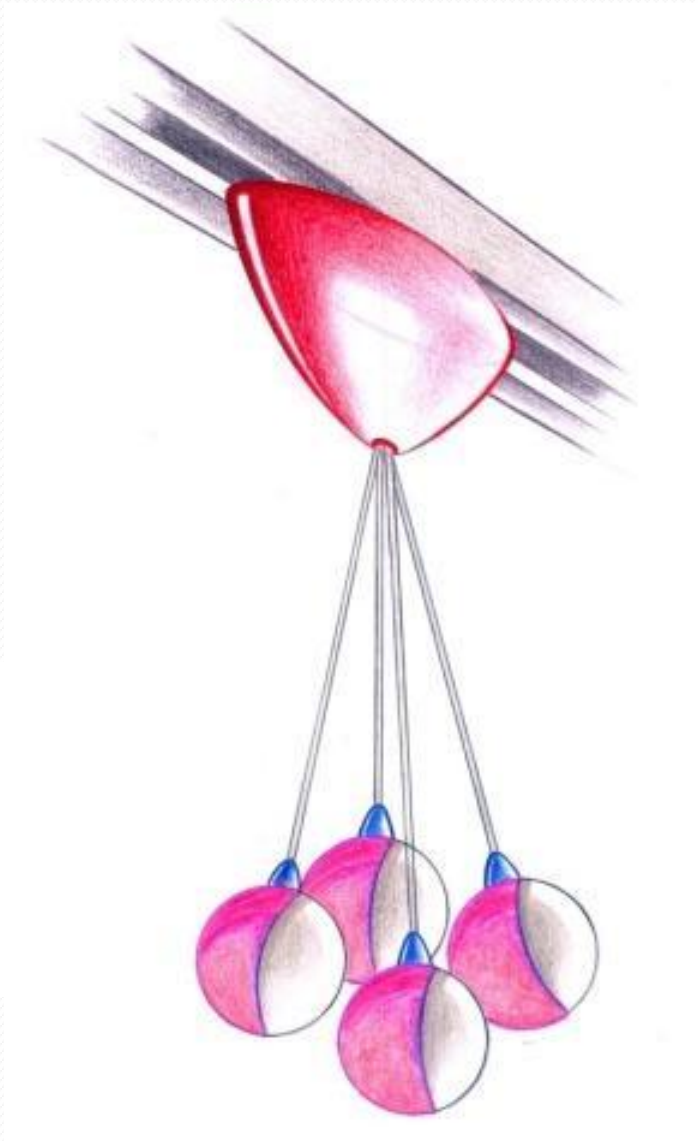



Track light using light balls, pink coloured led's used. It gives good light effect and this is ceiling track light:

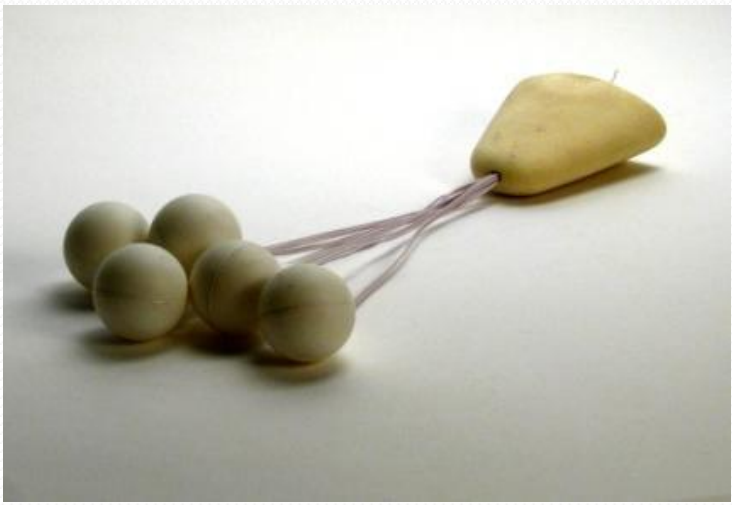

# Concept Evaluation

	Form	Ambience	Intensity	Power C.	Colour	Positioning	
Concept 1-A	5	5	5	7	4	6	32
Concept 1-B	6	5	5	7	4	6	33
Concept 1-C	7	5	5	7	4	6	34
Concept 2-A	6	7	7	8	2	8	38
Concept 2-B	8	8	6	8	2	2	34
Concept 2-C	9	8	6	8	2	2	35
Concept 3	9	4	3	9	2	8	35
Concept 4	9	9	9	5	9	8	49
Concept 5	9	7	6	8	2	2	34

# Final Concept



- Good Ambience
- Light intensity can be controlled
- Multiple Colour possibilities in the same light
- Easy positioning
- Can be fixed to wall or ceiling

Operates on 12 Volts  
RGB controlled LED's are used  
Remote Controlled product-comfort to operate

# References

## **Books/Magazines:**

Philips Lighting – 5<sup>th</sup> Edition Lighting Manual.

Lighting the work Place – Editors of PCB International.

Home Style.

Interior Spaces of USA.

The Best of Lighting Design – Wanda Jankowski.

International Lighting Design.

Designing with Light and Shadows.

Better Interiors.

## Internet/Websites:

<http://www.whatprice.co.uk/decorating/interior-lighting.html>

<http://www.sereneinteriors.com/interior-lighting.html>

<http://home.tir.com/~ms/interiorlighting/interiorlighting.html>

[http://www.cooper-ls.com/dg\\_int\\_ltg\\_des.html](http://www.cooper-ls.com/dg_int_ltg_des.html)

<http://www.decorating-interior.info/index.php>

<http://homedecor.iloveindia.com/mood-lighting.html>

<http://www.eia.doe.gov/emeu/cbecs/lit-type.html>

[apps1.eere.energy.gov/consumer/your\\_home/lighting\\_daylighting/index.cfm/](http://apps1.eere.energy.gov/consumer/your_home/lighting_daylighting/index.cfm/)

[www.house-energy.com/Lighting/Compact-Fluorescent.htm](http://www.house-energy.com/Lighting/Compact-Fluorescent.htm)

[www.bbc.co.uk/homes/design/lighting\\_types.shtml](http://www.bbc.co.uk/homes/design/lighting_types.shtml)

<http://www.seagulllighting.com/Indoor-Lighting.htm>

<http://www.indoor-lighting.net/>

<http://www.trinorthlighting.com/LED%2oLighting.htm>

<http://psychology.about.com/od/sensationandperception/a/colorpsych.htm>

<http://www.indiamart.com/illumination/indoor-lighting.html>

<http://www.ylighting.com/tracklighting.html>

<http://www.light-emotions.com/led-information.php>

[http://www.zumtobel.com/com/en/innovations\\_8284o.htm](http://www.zumtobel.com/com/en/innovations_8284o.htm)



Thank You!