

**Last Mile Personal Mobility Vehicle For  
The Urban Environment**

**MOBILITY AND VEHICLE DESIGN PROJECT III**

**BY**

**Anand A**

126390003

**GUIDE:**

**PROF. B. Bhaumik**



**INDUSTRIAL DESIGN CENTRE  
INDIAN INSTITUTE OF TECHNOLOGY  
BOMBAY**

**2014**

# LAST MILE PERSONAL MOBILITY VEHICLE FOR THE URBAN ENVIRONMENT

by  
Anand  
126390003  
Mobility And Vehicle Design

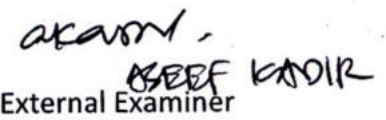
Project Guide  
Prof. B. Bhaumik

# APPROVAL SHEET

The Mobility and Vehicle Design Project 3 entitled "Last mile Personal Mobility Vehicle for the urban environment", by Anand A (Roll number - 126390003) is approved, in partial fulfilment of requirements of the Masters of Design degree in Mobility and Vehicle Design in Industrial Design Centre of Indian Institute of Technology, Bombay.




Project Guide  
Prof. B. Bhaumik



ABEER KADIR  
External Examiner



Internal Examiner



Chair Person

# DECLARATION

I declare that this written submission represents my ideas in my own words and where others' ideas or words have been included, I have adequately cited and referenced the original sources. I also declare that I have adhered to all principles of academic honesty and integrity and have not misrepresented or fabricated or falsified any idea/ data/ fact/ source in my submission. I understand that any violation of the above will be cause for disciplinary action by the Institute and can also evoke penal action from the sources which have thus not been properly cited or from whom proper permission has not been taken when needed.

Signature

Anand A  
Name of the Student

126390003  
Roll Number

Date

# ACKNOWLEDGEMENT

First of all I would like to thank my Project Guide Prof. B. Bhaumik for the support and valuable inputs he has given during the course of the project. I would also like to thank Prof. K Munshi, Prof. K Ramachandran and Prof. Nishant Sharma for their feedback and inputs on the project. I would like to thank my fellow classmates and friends in IDC and my family for being a constant source of support and inspiration throughout the project.



Anand A

Date - 19-8-2014

# ABSTRACT

My project will focus on coming up with a concept which offers a compact single person electric vehicle that allows the user to commute freely without much hassles. The project has various scope such as addressing the last mile connectivity issue or it can be a compact leisure and fun vehicle or a personal mobility vehicle to be used within an environment (ex. academic campus). The major focus will be on designing a last mile personalised transport solution that connects the commuter seamlessly with the public transport systems.

In the current scenario, the last mile vehicle which connects the commuter from his home/office to the public transport systems have a lot of bottlenecks. The commuter likes to use his own personal vehicle to connect to the local public transport networks. But the use of bigger vehicles occupies a lot of parking space and a lot of hassles. The project aims to come up with an electric bike as a solution for the last mile. The main feature of the electric bike will be its carry-ability when not in use. Hence when the commuter uses the public transport like trains, he/she can carry his personal vehicle with him thus allowing larger portability and transportability.

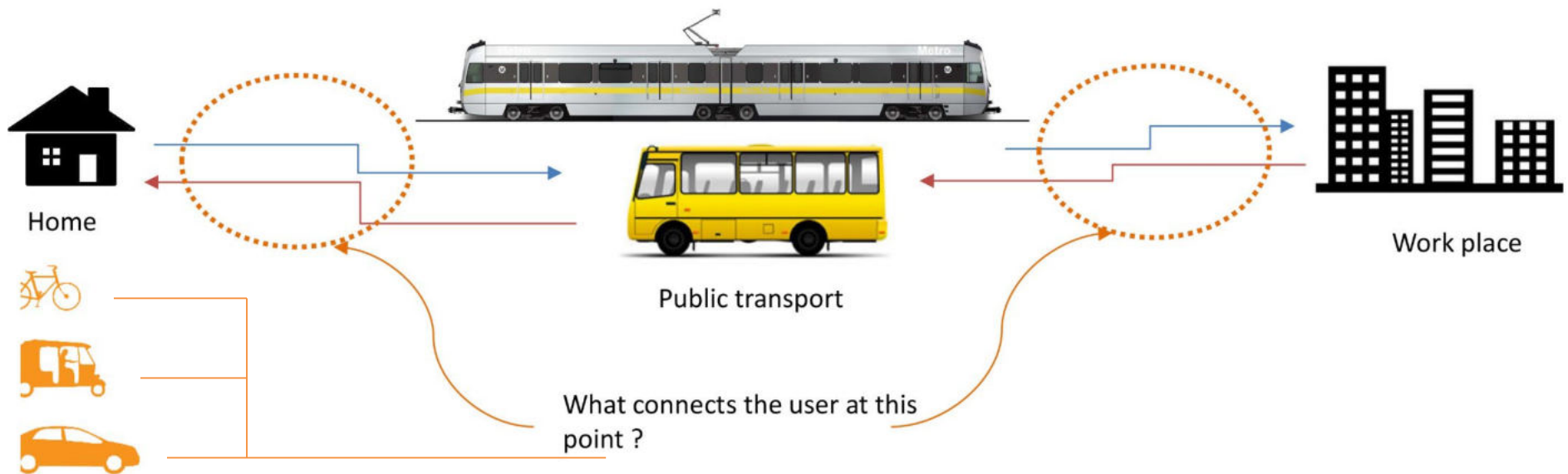
In this project, various compact electric vehicle possibilities will be explored and a design which addresses the user needs such as compactness, light weight will be addressed. A preferred riding posture along with the user requirements will be arrived at and a design which addresses the issue of portability of the vehicle (when not in use) will be proposed with a possible mock-up of the final design solution.

# CONTENTS

INTRODUCTION	1
PRE-RESEARCH	3
PRE-RESEARCH FINDINGS	5
USER STUDY	9
TREND STUDY	14
TECHNICAL STUDY	22
DESIGN BRIEF	29
CONCEPT EXPLORATIONS	30
FOLDING CONCEPT EXPLORATION	42
POSTURE STUDY	52
FINAL CONCEPT	54
CAD DRAWING	59
PHYSICAL MODEL	60
REFERENCE	62

# THE LAST MILE

With increasing stress on the need to shift towards public transportation, Bridging the last mile (or first mile) at the start and end of the daily commute from home to work and back was seen as one way in which we can improve personal mobility and encourage people to make better use of public transport, and hence rely less on the car which congests the urban roads.



It is estimated that Indian urban population will be reaching around 590 million by 2030 (this relates to the population of Indian cities only) and around 250 million population\* will be concentrated in Indian cities within 20 years. With growing population in urban cities, and increasing personal transport, there will be more congestion on roads as more and more people want to commute daily. Further the increase of suburban space near these cities also contribute to this factor.

Private motorization is growing in India annually at a rate of 11 percent. There is also a decrease in public transport usage by people because of the hassles involved in services, over-crowding, problems in feeder service systems etc. Hence there is a need for a steady shift of people to public transport in cities to reduce congestion, travel time and pollution on roads.

With more stress on improving the public transportation within the cities, new train services are in the pipeline. More metros/bus rapid transit systems are being planned in various city lines. But the shift to use of public transportation will happen efficiently provided if there is proper last mile connectivity for the commuter.

Public transport systems are limited by their lower accessibility (in terms of direct access from trip ends); on the other hand, private modes offer a variety of advantages such as demand mobility, comfort, status, speed, and convenience. Enhancing accessibility, mobility, convenience and comfort to a considerable extent, of rapid transit systems will make the people to shift for public transport systems.

The prime advantage that private modes offer over public transport is direct access from and to trip ends and this is where perhaps the focus is

\*Source - a study by World Research Institute and Embarq India on 'Sustainable Urban Transport in India' <http://embarqindia.org/node/226>

# PRE - RESEARCH

A research questionnaire is prepared to just study the general user behavior when it comes to last mile transportation. The questionnaire survey is done in Mumbai of users between age group of 16 to 40 ( students and office goers).

No. of users surveyed – 25

Age group – 16 to 45

Male users – 18

Female users – 7

Area - Mumbai

# RESEARCH QUESTIONNAIRE

Name -                      Gender-                      occupation -                      Age -

1. What is your often commuted route and how do you commute daily?

2. How frequently do you use public transportation system?

- Very frequently
- Less frequently
- I have my own personal transport

3. What are the difficulties you face while daily commuting?

4. How much time do you take on travelling daily?

5. How do u prefer to commute daily?

- By personal transport
- By train/bus
- By bike
- Combination of personal and public transport

6. If you are travelling by train or bus (public transport), how do you reach the station or stop?

7. Do someone drop you at the station      Yes                      No

8. Does the current system connect you till the last mile (i.e. from your departure point to destination) and first mile?

9. Do you use the private vehicle parking system in railway stations? If yes, how do you find the current parking scenario in railway stations?

10. Do you carry any luggage with your daily travel? If yes, what type of luggage do you carry?

11. Do you commute alone or in groups?

12. In what other scenarios, do you find the need for a powered vehicle to move around?

13. Which of the following powered vehicle would you prefer for commuting?

Electric powered skateboard



folding cycle with power assist



Segway



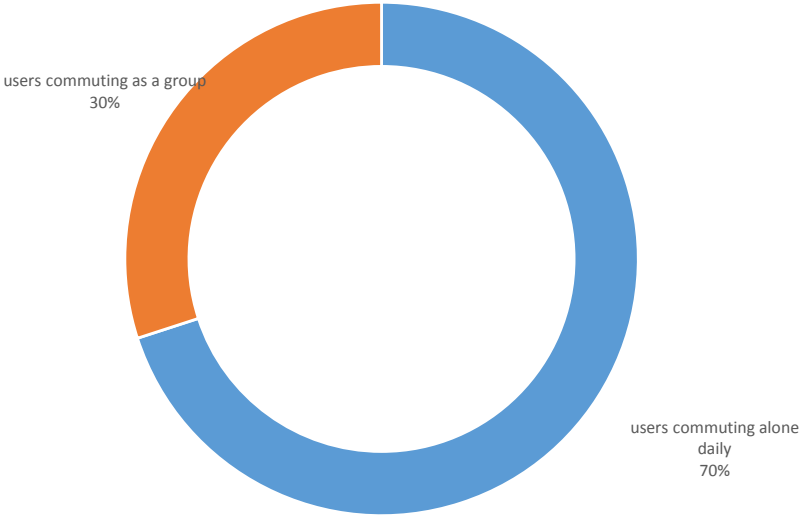
Toyota I-real concept



14. What are the features you would look for if you are given a last mile personal transport vehicle?

# PRE- RESEARCH FINDINGS

Is there a need for a single person last mile vehicle?



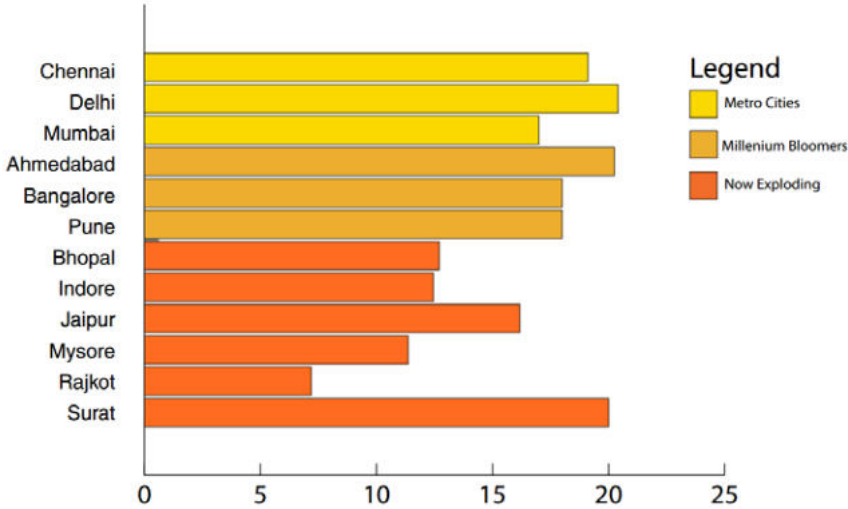
It is found that around 70% of people travel alone daily. As compared to commuting in groups, the ratio of commuters traveling alone is very high. Even many users who have a personalized four wheeler is commuting alone most of the time.

## TIME SPENT ON COMMUTING

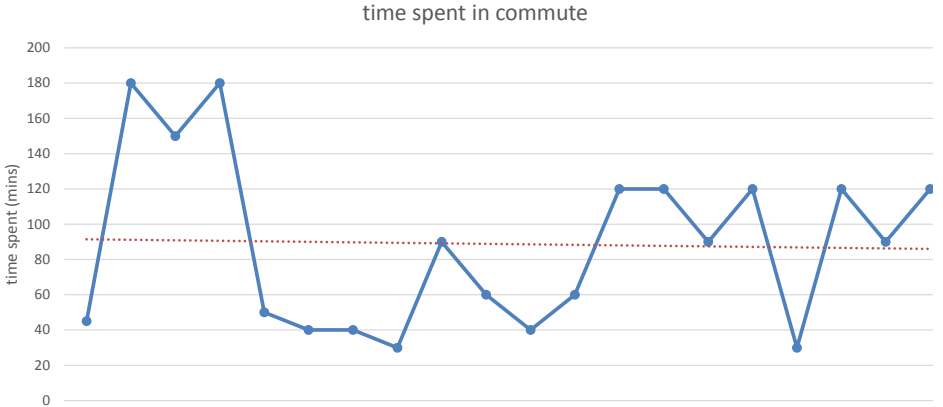
Everyday on an average people spend around 1.5 hours in commuting itself between their home to workplace. This includes the train journey time. Of the total commuting time, more time is spent in the last mile compared to the travel time in trains. Further the average travel speed of people in urban cities of India is of around 15 km as per Embarq India study. The commuting speed will be decreasing more with increasing population and congestion.

### Travel Speeds

kilometers per hour

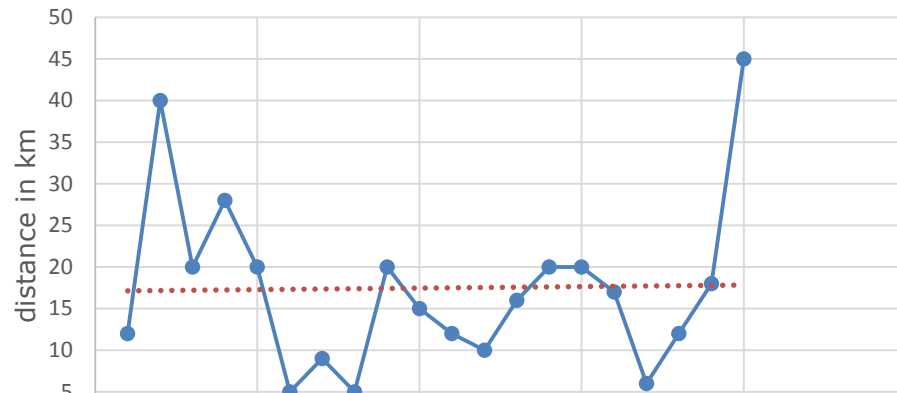


source - <http://embarqindia.org/node/226>



## DAILY COMMUTING DISTANCE IN CITIES

average distance travelled

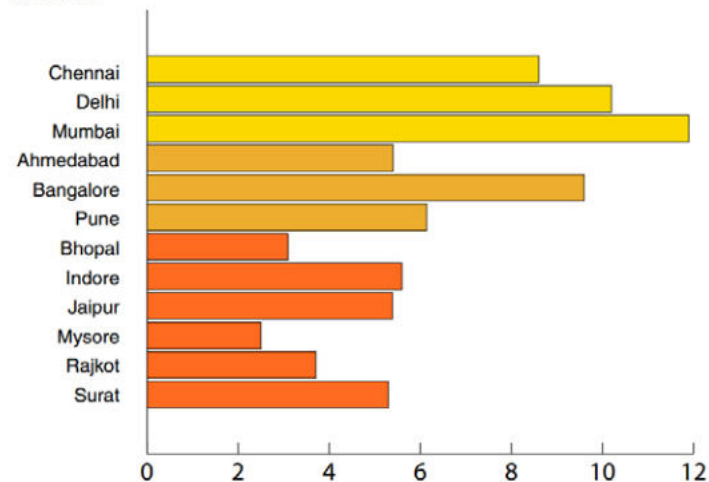


From the user survey, the average distance travelled everyday in Mumbai is found to be around 15 kms. The distance includes the journey in the main public transport also. Last mile part covers 4 to 5 km of the average 15 km journey everyday which is around 35% of the total commuting.

This data is further validated by the study from Embarq India titled on transport in Indian cities – indicators. It shows the average daily commute people make in urban cities of India as studied by Embarq India. As seen, the average trip lengths in metros are over 8 km. And this trip length includes the distance travelled in public transport and is showing an increasing trend with increasing suburban areas in cities and more woman joining labour forces in cities.

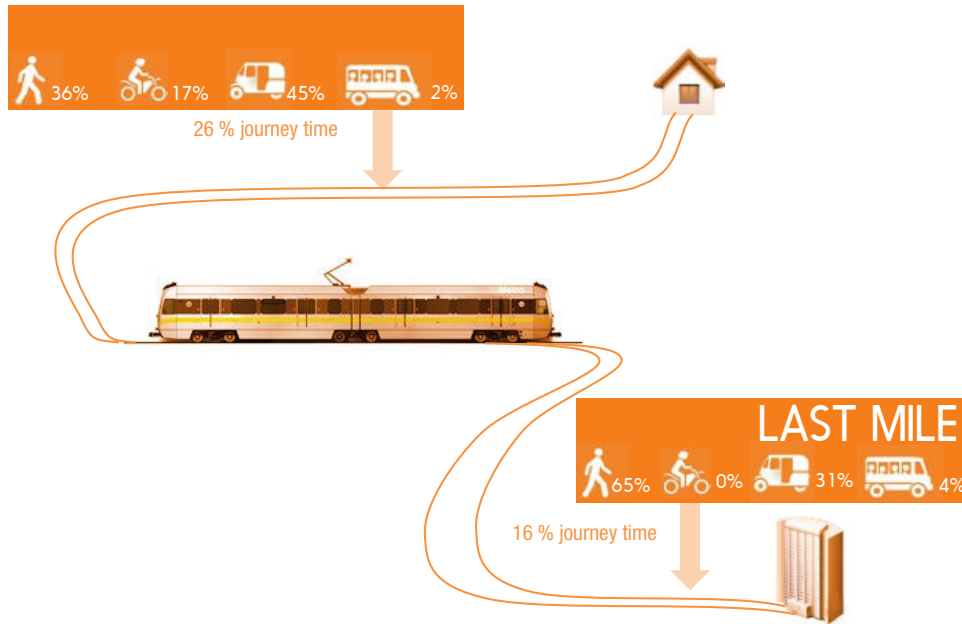
This data can be used to derive the range requirement of the last mile vehicle.

Average Trip Length   
kilometers



source - <http://embarqindia.org/node/226>

## CURRENT SCENARIO



### MODAL SHARE DISTRIBUTION IN DELHI

The above illustration is as per the study given in the paper titled 'LAST MILE CONNECTIVITY (LMC) FOR ENHANCING ACCESSIBILITY OF RAPID TRANSIT SYSTEMS' published in 13th International Conference on 'Mobility and Transport for Elderly and Disabled Persons' in 2012, New Delhi.

For a larger mass cycling and walking are the only solutions for negotiating the final stretch that public transport doesn't reach. A report drafted in 2008 by Mirabilis Advisory\* says, "In bigger cities, the proportion of people using conventional public transport was high, and consequently commuters walked the last mile". As per the report, in cities with more than 8 million population: 22 percent walked all the way, 8 percent used cycles and 44 percent used public transport. This adds up to 74 percent of people who rely on public transport for at least part of the commute.

These pie charts illustrate the distribution of modes at the first mile (origin to Metro station) and last mile (metro station to destination) sections respectively in New Delhi. It can be seen that auto rickshaw and walking are the most favored mode in the first mile (with an almost equal share between the two); together they comprise almost three-fourth of all the modes put together. In case of the last mile walking is the predominant mode; this may be contributed to several factors, such as shorter distance between alighting metro station and final destination, non-availability of cycle-rickshaws and/or other feeder services at metro stations near work ends.

[http://www.transed2012.in/Common/Uploads/Theme\\_E%20Session%201%20Regency%201/380-paper-transedAbstract00073.pdf](http://www.transed2012.in/Common/Uploads/Theme_E%20Session%201%20Regency%201/380-paper-transedAbstract00073.pdf)

\*source - <http://www.habitatsummit.org/pdfs/Executive%20Summary.pdf>

As per the infographics in the previous page, more than half of those who took a two-wheeler (motorcycles, scooters and mopeds) in the first mile stretch, opted to walk at the last mile end. Three-fourth of the commuters who took an auto rickshaw in reaching the metro, walked to their destination from the metro. It is also interesting to note that not a single commuter took an auto-rickshaw at both ends of the journey. This points to two things: that commuters are not willing to travel a larger distance to/ from the transit stops at both ends of the commute and that they want to keep the cost of the overall journey low.



Walking is the most common way of last mile transportation. Many commuters are forced to walk because of lack of connectivity or due to high transportation costs involved. A personalised vehicle that occupies less space and less operating cost can be a solution.



In case of two wheelers being used as first mile feeders, it is only one way i.e. it covers only one half of the commute. Parking space has been a major issue when bike/cycle is used for last mile connectivity. Congested and non availability of parking space, difficulty in parking, getting the bike out of the parking space, fuel charges are some of the bottlenecks related to it.



Though auto-rickshaws are popular feeder system in India, the commuters find the cost of journey to be high. Commuters find that getting auto rickshaw also requires a long wait due to high demand. Further increase in rush hour demands, high traffic and auto drivers refusing for short distance travel and improper fare rates are some of the issues which the user faces currently.



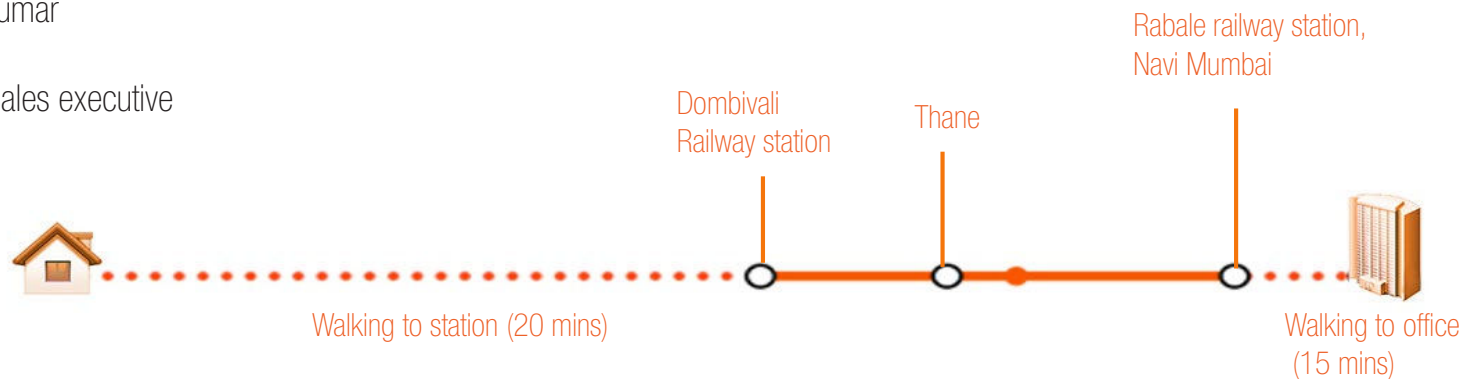
Buses are least used feeder services due to improper infrastructure, timings and traffic congestion issues. Further bus systems do not completely provide an end to end last mile solution as it does not connect the user till the end.

# USER STUDY



Name : Dilip Kumar  
Age : 28  
Occupation : Sales executive

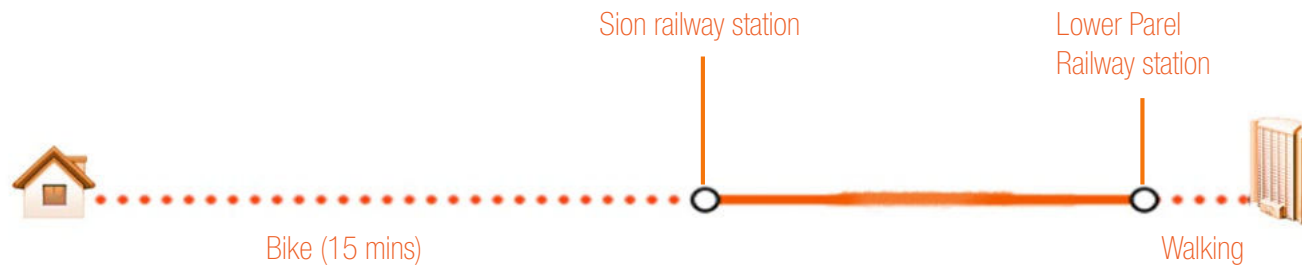
- Has to go on Customer field visits 3 times a week
- Travels in train from Dombivali to office or to customers within Mumbai in peak hours
- Carries a laptop, water bottle, catalogs
- Has to find routes and navigate while going on field visits
- Also goes outside Mumbai for field visits
- Does not buy a bike because of parking issues and travel time





Name : Ravi chauhan  
Age : 32  
occupation : Engineer

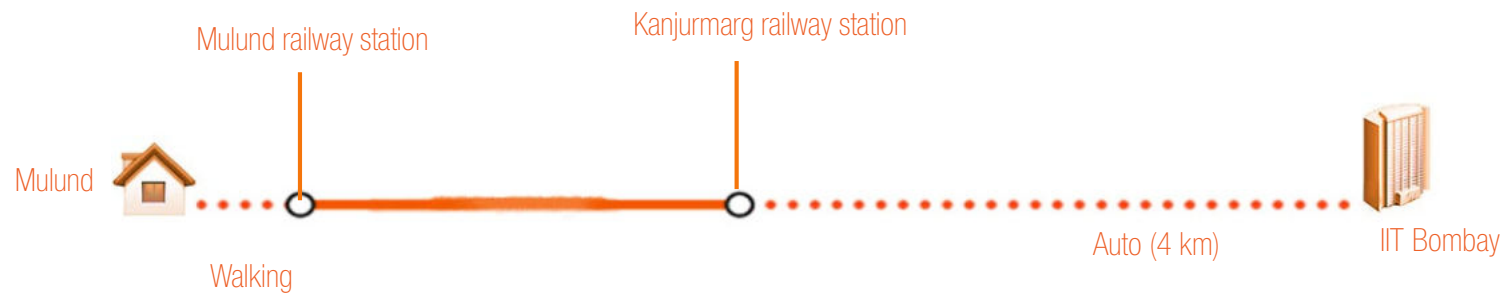
- Goes to office through trains. Uses a scooter as a last mile transport
- Does not use the bike as full transport because of operation costs, and traffic
- Bike parking issues
- The bike only covers the one part of the last mile. For the other end (i.e. from Lower parel station to office) he has to walk for around 15 minutes or wait for an auto rickshaw
- Has a pet dog (pet) which he carries with him when he goes for shopping or nearby





Name : Shashank Sawant  
Age : 22  
student

- Goes to college
- Uses auto rickshaw as last mile solution
- Walks around 5 kms within the campus only
- Commutes with his girlfriend
- Meets up with his friends in hiranandani
- Likes to ride bikes, goes for trekking every week, cycles a lot



# EXPRESSED AND UNEXPRESSED NEEDS FROM USER STUDY

- Need for a short range mobility solution which reduces the travel time and easy to use
  - Reduce the problems associated with parking
  - Compact and light weight so that it can be moved around in trains/buses
  - Should be easy to load and unload the vehicle from trains/buses
  - Can have luggage spaces if required
- 
- Should be able to move through gradient area where climbing a slope is required
  - Protection from dust and atmosphere
  - Safer to ride
  - Can be folded and accommodated inside cars/auto incase traveling in a group
  - Can have weather protection incase of rain
  - Comfortable riding posture

The needs highlighted in orange is given more focus to form the design brief as they address the basic needs

## Last mile connectivity



System level solution  
(a shared vehicle system)



Wearable mobility



Use and carry



Product level solution

The issue of last mile can be tackled by system level approach through some feeder vehicle sharing system or by product level approach that is more personal to the user. I opted for a product level approach to give the user a personalized feel and connect him till the end of the mile completely without hassles.

# PERSONAL MOBILITY VEHICLE - TREND STUDY

## SEGWAY



The Segway is a two-wheeled, self-balancing, battery-powered electric vehicle. It is the first commercial last mile vehicle are driven by electric motors that can reach a speed of 21 kmph. The main feature of segway is the balancing with only two wheels placed parallely. It balances with the use of a gyro and easy to ride. The user commands the Segway to go forward by shifting their weight forward on the platform, and backward by shifting their weight backward.



Segway performs best in areas with adequate sidewalks and are generally used in cycling lanes and sidewalks. In most of the countries, the typical areas where it is used more often are in theme parks, airports and by security personnel in the US.

<http://www.segway.com/>

## BOASTED BOARDS



San Francisco-based startup Boosted Boards has produced an eponymous electric skateboard prototype capable of providing a push-free ride for up to 10 km. While an electric skateboard isn't anything new in itself, this particular longboard is declared by its makers to be the world's lightest electric vehicle. It is not only a compact electric vehicle but also fun to ride for the user.

Motor power: 2000 W  
Top speed: approx. 32 kmph  
Range: approximately 10 km  
Maximum grade: 15 percent  
Charge time: 2 hours  
Battery: Lithium  
Weight: between 5.5 – 6.8 kg



<https://www.kickstarter.com/projects/170315130/boosted-boards-the-worlds-lightest-electric-vehicle>

## URB - E

Urb-E is foldable powered bike that can be pulled along like a luggage case. This allows the electric bike to be used as a last mile connecting vehicle and can also be towed along easily while boarding in trains.

Speed – 24 kmph

Range – 32 km

Light weight made of aluminum



<http://urb-e.com/product.html>

## YIKE BIKE



Yike Bike is an electric commuter like the Segway. But unlike the it mostly looks like you're just riding a bicycle and in the same time also looks very conceptual and fun to ride. It is an ultra portable folding electric transport that rides like a bike without pedals. It folds to just 1.52 cubic feet, weighs less than 25 pounds and can be lifted with one hand. It has sophisticated electronics include front and rear lights, turn signals, blinkers, horn chirp and regenerative braking

Speed – 24 kmph

Range – 14 km

Weight – 9.2 kg

Charge time – 1.5 hours



[www.yikebike.com](http://www.yikebike.com)

## SPNKIX – WEARABLE MOBILITY



SpnKiX is a Battery powered, motorized skates that strap right on to your shoes. They are hand controlled by a wireless remote. All hardware and electronics are integrated into a frame made of fiber reinforced nylon. One motor and battery pack per foot. The skates consist of two motorized wheels on either side, with a battery pack installed within the back of the unit, which also features a safety reflector on its exterior. two ratchet straps along the fiber reinforced nylon frame secure the devices to any kind of shoe. Remote-controlled, the skates permit users to vary their throttle and speed at will, or walk, climb steps, and even drive a car normally when not activated. Although each charge lasts about two to three miles, the batteries are removable, so users can bring a backup supply in the case of longer trips; each attains a full charge in about two hours.



Materials: Fiber reinforced Nylon + Aluminum

Batteries: Rechargeable lithium

Max Speed: up to 16 kmph

<https://www.kickstarter.com/projects/petertreadway/spnkix-wearable-mobility>



[http://www.toyota-global.com/innovation/personal\\_mobility/i-real.html](http://www.toyota-global.com/innovation/personal_mobility/i-real.html)

## HYUNDAI E4U CONCEPT

Further personal mobility as such is explored more as concepts by Auto companies like the E4U concept showcased by Hyundai at Seoul Motor Show 2013. Hyundai's egg-shaped vehicle sets itself apart by sitting atop a horizontally-spinning semi sphere that is used for propulsion instead of wheels. The driver stands on a small platform and directs the vehicle by tilting it so that different sides of the semi sphere contact the ground.



<http://green.autoblog.com/2013/04/09/hyundai-unveils-e4u-ev-eggs-seoul-motor-show/>



<http://world.honda.com/UNI-CUB/>

## TOYOTA I-REAL CONCEPT

The space-age i-REAL is a concepts developed by Toyota. Powered from a lithium-ion battery, the three-wheeled machine has a range of 30km on a single charge, and can hit speeds of up to 30km/h. For that kind of speed, it drops from its upright Walking mode into a lower and longer Cruising posture, and is able to tilt into the corners. At the end of the trip, it contracts into the smaller footprint of Park mode, which comes close to fitting into a large cupboard.

## HONDA UNI-CUB

Honda came up with the Uni-cub personal mobility concept in 2013. It has Omni Traction drive system, in which the rear wheel moves laterally in order to make turns easier. This allows side-to-side and diagonal movement, in addition to the ability to turn in place. The UNI-CUB moves in whichever direction the rider shifts his or her weight, and control through a smartphone's screen is also possible. It can travel at about 3.5 mph and its battery lasts about an hour when continuously run.

# STUDY OF EXISTING FOLDING BIKES

After intial explorations for folding, some of the existing folding bikes that are sold were studied.

## BERGMONCH FOLDING BIKE

The Folding Bike Bag by Bergmönch is a backpack and a fully spring-mounted downhill cycle. It weighs 9.5kg and folds up into a small pack that hikers carry on their back while ascending the hill or mountain. It does not have luggage space and designed for mountain bike posture.



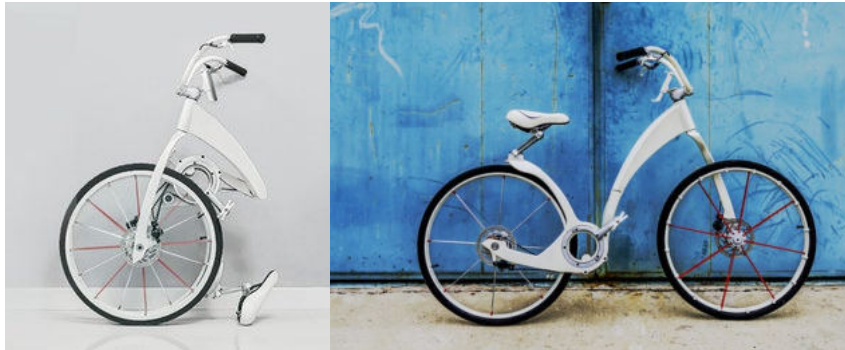
<http://bergmoench.koga.com/de/>

## BROMPTON FOLDING BIKE

Brompton is the first successful folding cycle which had its first production run in 1988. In the year ending March 2014, it sold 45,000 of its folding bikes. Held from the saddle, it hangs at your side like a well-balanced suitcase. The fold sequence given below takes only around 10 seconds to achieve.



<http://brompton.com/>



[https://www.kickstarter.com/projects/227461008/gi-bike-the-light-full-size-electric-folding-bike?ref=nav\\_search](https://www.kickstarter.com/projects/227461008/gi-bike-the-light-full-size-electric-folding-bike?ref=nav_search)

## GI BIKE

The bike can collapse to half its original size in just three seconds, making it ultra pub trans-friendly and a perfect option for cyclists who live in small spaces. Other than foldability it has light weight Aluminium frame, smart-phone activated lock and usb port. It is a keyless electric bike which easily folds to a manageable size with a simple flip action






## FOLDING E- BIKE BY GABRIEL

The folding commuter bike designed by the design house Gabriel has started production. It has a light weight carbon Fibre frame with Lithium battery and a 200 watt motor. Because of its carbon fibre frame, it is easy to carry



[https://www.kickstarter.com/projects/1585753369/folding-electric-bike-for-commuters?ref=nav\\_search](https://www.kickstarter.com/projects/1585753369/folding-electric-bike-for-commuters?ref=nav_search)

# TECHNICAL STUDY - COMPARISON

	Top Speed (km/hr)	Range (km)*	Motor Type	Power (watts)	Weight (kg)	Battery Pack	Charging time	Wheel Size	Foldability	Frame/chassis
 <p><b>Yike Bike</b></p>	23 km/hr	14 km	Electric Brushless DC motor	450	9.2 kg	Lithium ion	1.5 hours	20" front 8" back	collapsible to 43 liters volume	Carbon fibre composite/ alloy and reinforced polymer composite
 <p><b>Boasted Boards</b></p>	30 km/hr	10 km	2 Electric Brushless outrunner DC motor (generally used in RC planes)	2 X 1000	around 6 kg	Lithium ion	2 hours	4.5"	compact since it is a skateboard, so easy to carry	Fibreglass sandwiched in Bamboo Core
 <p><b>Segway</b></p>	20 km/hr	26 to 39 km	Electric motor	1000	around 45 kg	Lithium ion	5 hours	19"	non collapsible	metal and plastic
 <p><b>Spnkix</b></p>	16 km/hr	11 km	4 Electric Brushless DC motor (2 per each shoe)	2 X 80	8 kg	Lithium ion	2 - 3 hours	9"	wearable mobility and hence very compact	Fiber reinforced Nylon + Aluminum
 <p><b>Urb - E</b></p>	24 km/hr	32 km	Electric Brushless motor	250	13 Kg	Lithium ion	3 hours	10" front 6" back	fold and pull like a luggage box	Aluminium frame

\*Range data is considering a person of around 80kg riding on a smooth surface

From the given comparison chart in the previous page, different drive power is used. The average drive power required for travelling at around 20 kmph is around 250 watts as used in URB-E. (provided the vehicle weight is around 10 kg. it is higher incase of segway). This power is enough to drive low speed of around 15 to 20 kmph. Several bike conversion kits also have a minimum motor of power rating 250 watts.

The main factors which might contribute to the Design are as below. this is as per the expressed ad observed needs of the commuter

- Range
- Compact and easy to carry
- Carrying weight
- Collapsibility
- Ease of riding
- Provision for carrying laptops / notebooks

## Range

From the previous study it is found that the average distance commuted by people in cities in the last mile is around 5 to 6 km. From this data, a range of 10 km desirable.

## Weight and compactness

It is necessary to find the carrying capacity of the commuter as he will carry his personal vehicle in public transport systems. It is important to find the target volume and weight data that a commuter can carry inside the train. For this reason, a study is done to carry a particular volume luggage inside the Mumbai sub-urban trains. An average city commuter will carry a baggage consisting of laptops / notebooks which will weigh tentatively around 4 kg. In addition to that, he has to transport his vehicle in the trains.

In case of carrying the vehicle inside the Mumbai train, the passenger is more comfortable with a suitcase/backpack. A trial is done by filling backpack/suitcase with a weight of around 15 kg and boarding/alighting the Mumbai local train. It is a general guideline not to carry more than 1/3rd the weight of a person in backpack. Hence a weight of around 13 kg is chosen as it includes the weight of 4 kg of laptop and other stuff (person weight taken to be 80 kgs )\*

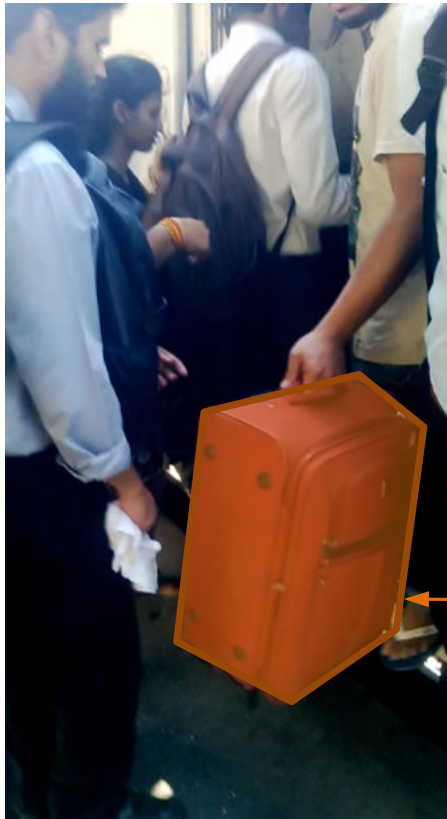
During peak hours, the Mumbai suburban trains have a super dense crush load of 14-16 passengers per square meter. (in a 9 car train of capacity 1700 passengers transports around 4500 passengers)\*. Also ingress/egress is a problem during peak hours. Hence peak hour scenario in general class coach travel is not considered. Moving in first class coach of the Mumbai sub-urban train is considered.

\*Source :

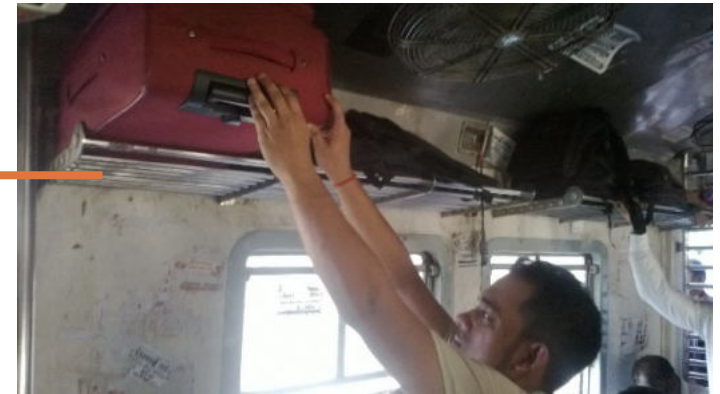
[http://www.idosi.org/wasj/wasj17\(11\)12/20.pdf](http://www.idosi.org/wasj/wasj17(11)12/20.pdf)

[http://www.airpacks.com/documents/facts\\_about\\_backpacks\\_and\\_injury.pdf](http://www.airpacks.com/documents/facts_about_backpacks_and_injury.pdf)

First the trial is conducted with a suitcase bag filled with 13 kg weight. It was conducted around 5 pm (peak hour) in Thane railway station, Mumbai.



luggage space inside trains



the user has to carry the vehicle in crowded over bridges



45 X30 X20 cu.cm



50 X30 X15 cu.cm



Second, the trial is conducted with a backpack filled with 13 kg weight. It was conducted around the same time 5 pm (peak hour) in Thane railway station, Mumbai.

It is found that ingress/egress inside the train with the backpack is much more easier. Also the backpack is easy to carry in over-bridges. Based on this exercise done to gauge the feasible luggage carrying capacity inside trains, the maximum volume requirement is found to be 22000 cu.cm (i.e. of the size of the backpack)

As for the target weight, the feasible backpack capacity that has less strain effect on the carrying person is around 12 kg. Assuming the weight of other carried items like laptop, books etc., to be around 3 kg, the requisite final target weight of the design should be around 9 kg.

Note that the target volume is the volume for carrying the vehicle and not for riding it. Hence the design can incorporate various collapsible solutions that can be folded and carried around when the vehicle is not in use.

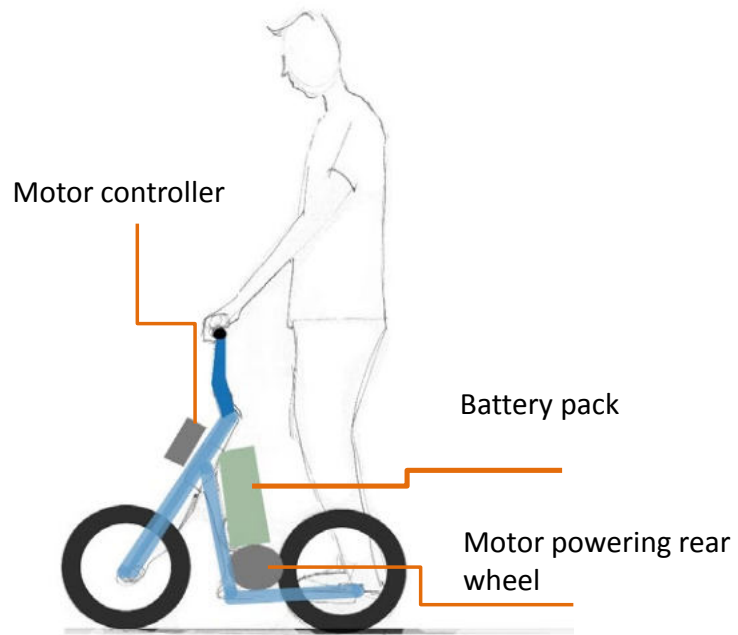
## Riding Posture

Since the last mile commute is not a very long distance travel, a standing posture is fine. Provision for sitting comfortably will only add advantage to the final design.

# DRIVE TRAIN & BATTERY

A basic layout was made to check the possible weight and posture height. A typical cycle layout was chosen with 14 inches wheel as it is the minimum size in which the hub motor will fit. It is found the motor occupies more space if it's a hub-less drive. Further the chain drive to the rear wheel constraints the folding of the vehicle.

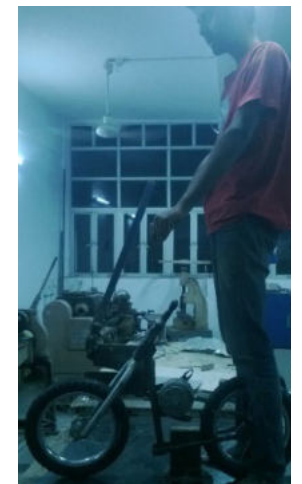
- Brushless Motor weight – around 2.4 kg
- Lithium Battery weight – around 3 kg
- Motor controller – around 500 gm
- minimum weight possible – 7 to 8 kg (including wheels and frame)



180 Watt DC motor  
(weighs 3.15 kg)



14" wheel



## DRIVE TRAIN - BRUSHLESS DC HUB MOTOR

Brushless DC motor is more preferred in such applications as DC motor is portable, less weight and has low maintenance factor and compact.

Hub motor

occupies less space

lighter and compact in construction

no additional drive mechanisms requirement

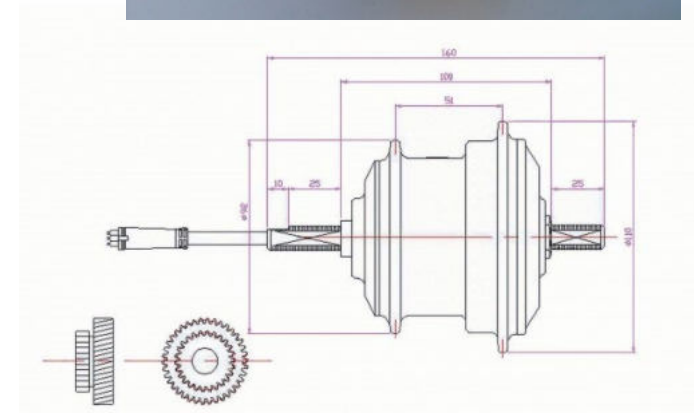
hubless motor

occupies extra space and adds mounting constraints

comparatively heavier

addition of driving mechanisms like chain drive adds to complexity and constraints for folding

The size and weight of the motor matters the most as this defines performance and compactness of the vehicle. The most compact motor available is a Brushless DC motor of power rating of around 200 to 350 watt rating which is found to be enough to power a small bike. Based on these power requirements, a brushless DC hub motor is relevant with power rating of around 250 watts.



The basic specification of a compact 250 watt brushless dc hub motor that is available is given below:

Power: 250 watts

Weight: 2.1Kg

Voltage: 36V

Efficiency: around 78%

Hub Diameter: 126.5mm

## BATTERY - LITHIUM ION BATTERY PACK

As per the user research, the average last mile commute distance in India is around 5-6 km in cities. Based on this data, a range of around 10 km is considered.

Motor power requirement = 250 watts

Range requirement = 10 km

Watt hour/ km = power / range = 250/10 = 25 watt hr/km

Rated voltage of the motor = 36 volts

Battery capacity = Ampere hour / km = watt hour/km / rated voltage = 25/36 = 0.694 A hr/km

Battery capacity is rated in ampere-hours, which is the number of hours for which the battery can produce a current of one ampere of current before the battery is exhausted. In this case, 0.7 A hr defines that the battery can supply 0.7 A for 1 hour or 1.4 A for half an hour or 3 A for 15 minutes and so on.

Lithium ion batteries are preferred as they are around 30% less heavy compared to lead acid battery and also compact. Also the charging time of Lithium ion battery is very low. To drive a 36 V motor, the following battery options are available. Further Lithium batteries can also be made to any shape as they are a stack of battery cells.



Length 366 mm  
Diameter 102 mm



Size 80\*120\*300mm



Size 80\*120\*300mm

# DESIGN BRIEF

To design a single person last mile mobility vehicle that can be carried around when commuting in public transit systems with the following specifications

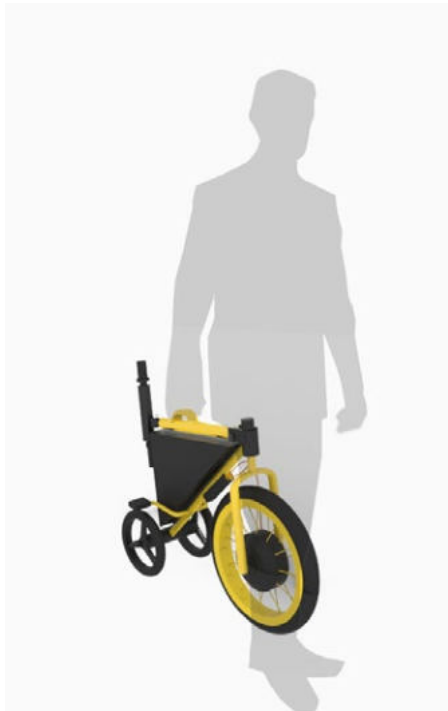
- powered by Brushless DC electric hub motor of around 250 watts with maximum speed of around 25 kmph
- has a range of 10 km
- should weigh not more than 9 kg
- should have a folded volume within 22000 cu.cm (the volume of a bigger backpack)space so that it is compact enough to carry or roll around to take it inside trains/buses

## Aesthetic Intent

The vehicle should look light and appeal to user groups of age around 16 to 40 years. It should also appeal to both female and male users.

# INITIAL CONCEPT EXPLORATIONS

CONCEPT -1

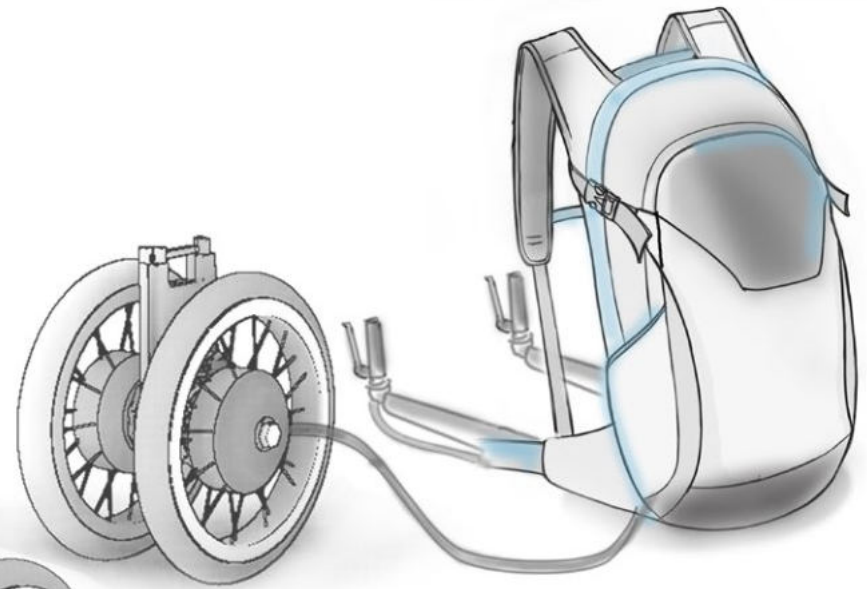


Battery

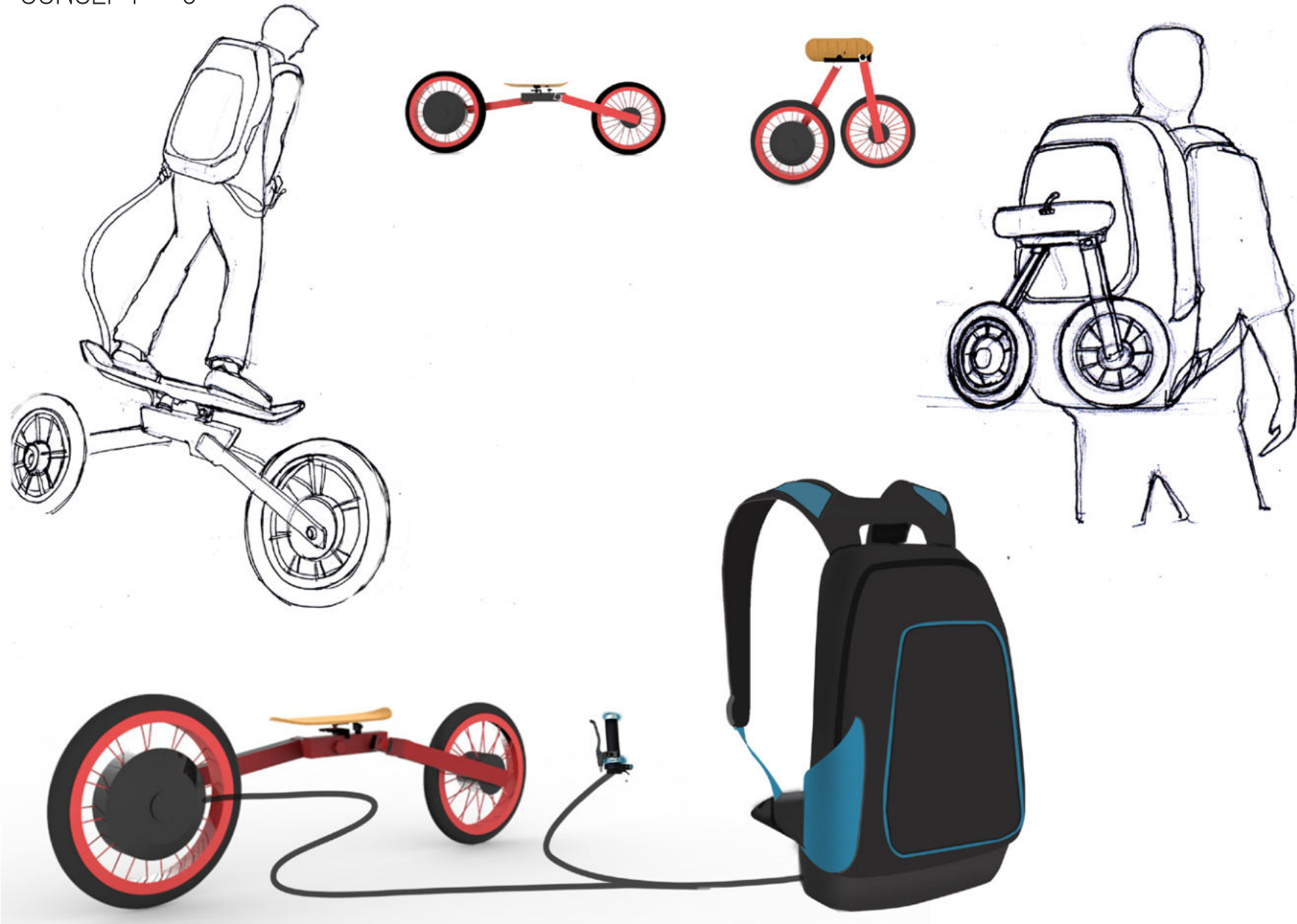
Hub motor



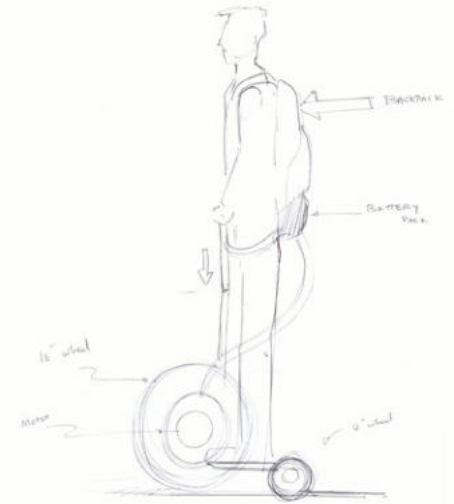
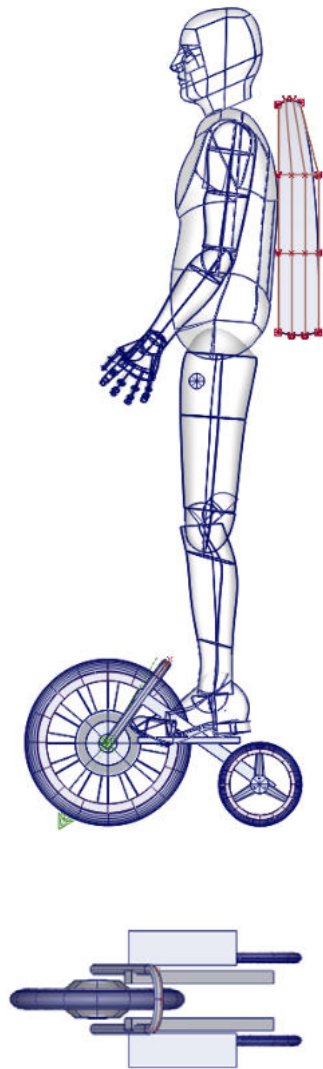
# CONCEPT - 2



CONCEPT - 3

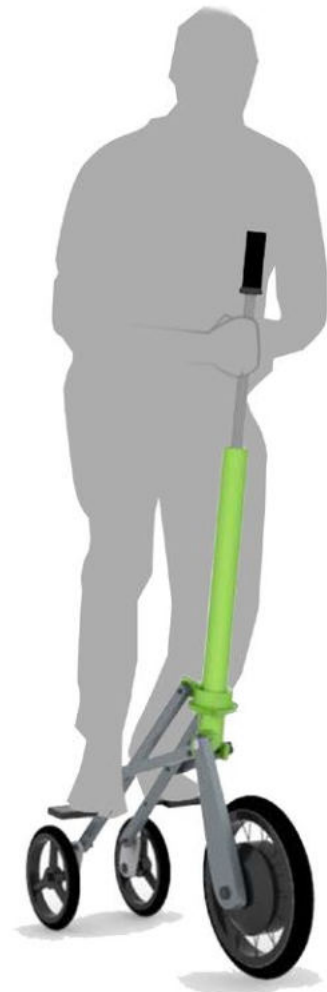


# CONCEPT - 4



Battery pack and controller in the backpack

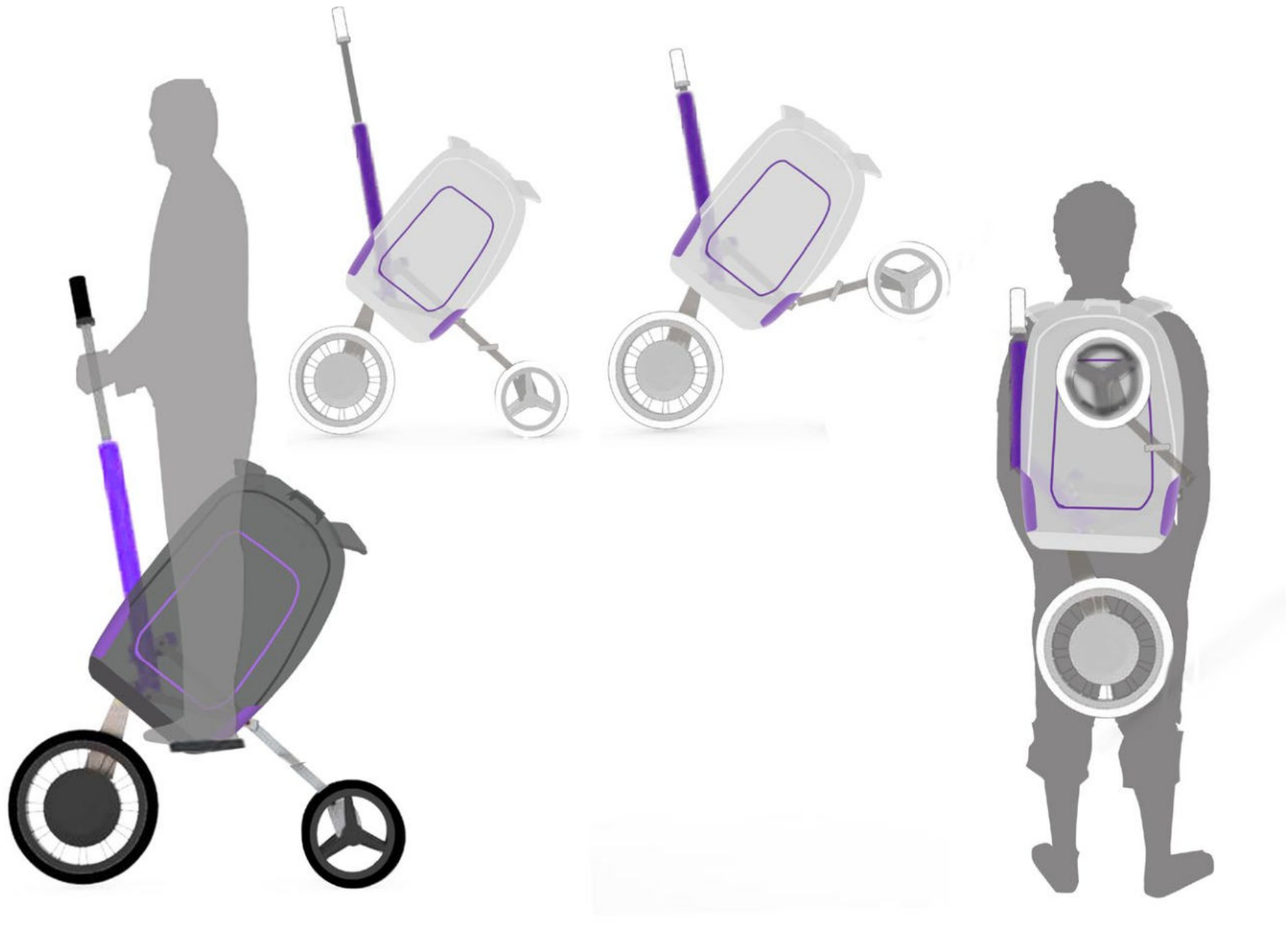
CONCEPT - 4 (VARIATION)



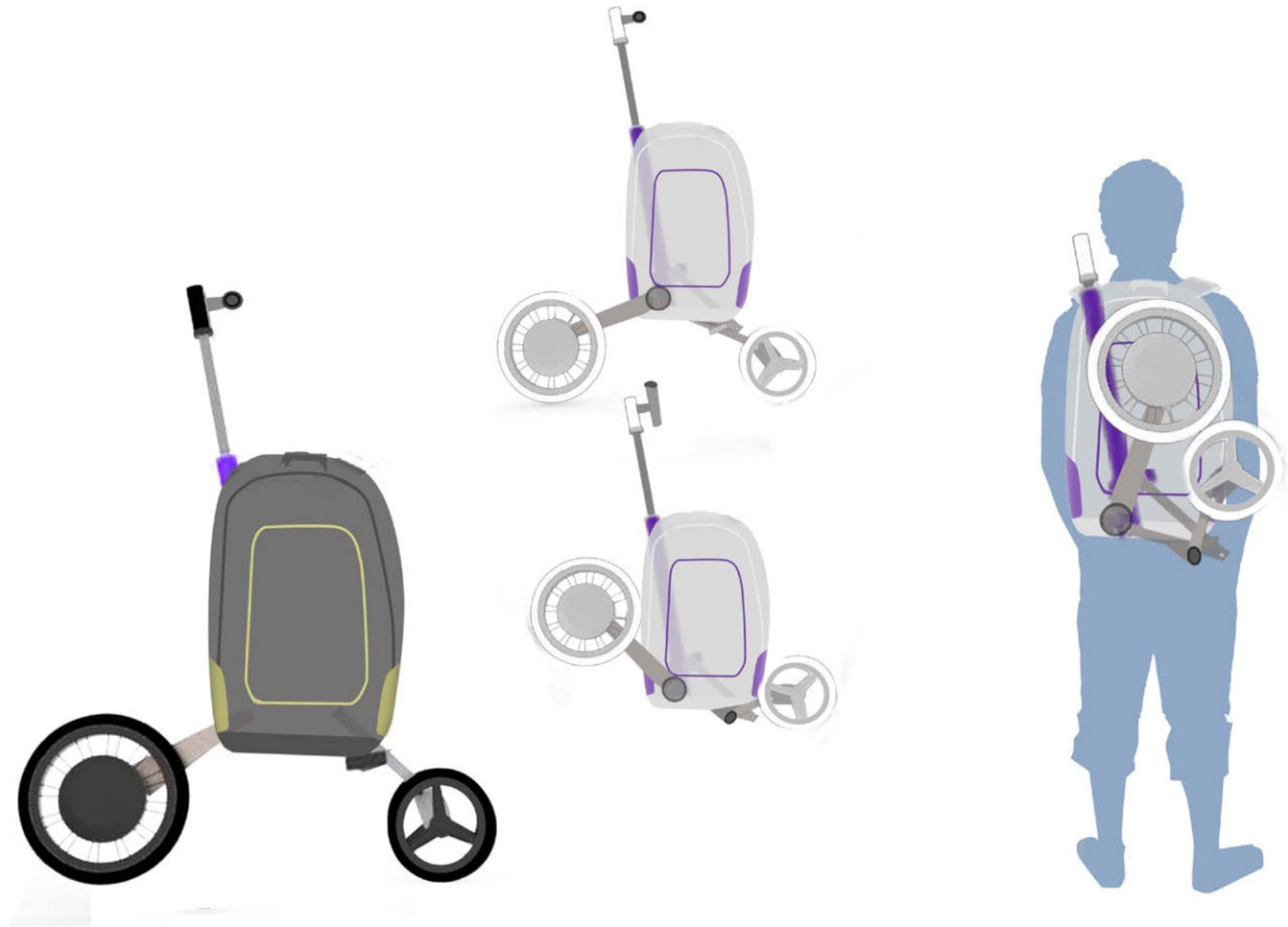
# CONCEPT - 4 (VARIATION)



CONCEPT - 5









# CONCEPT - 5 (VARIATION)



# CONCEPT - 6



The concepts are compared and rated on factors like compactness, collapsibility, folding complexity, ease of riding as below.

						
	concept 1	concept 2	concept 3	concept 4	concept 5	concept 6
Compactness	3	2	2	1	1	1
collapsibility	3	2	2	1	1	1
posture	sitting/standing	standing	standing	standing	standing	sitting/standing
provision for luggage	no	yes	yes	no	yes	yes
complexity in folding/carrying	1	1	2	2	3	3
weight	less weight	heavy due to use of 2 motors	minimal	minimal weight	minimal	minimal
ease of riding/turning	1	3	3	2	2	1

1 - high    2 - ok    3 - low

As from the above comparison chart, it is found that concept 6 has better compactibility and ease of riding since the riding technique is similar to a bike. Concept 6 has a regular cycle riding posture which is familiar for the user and has additional storage space. Also concept 5 with standing posture is also considered.

Mockups are made to the scale of 1:1 to find out the exact volume requirements and folding possibilities. The 1:1 scale folding mockup of concept 6 is made to figure out the basic dimensions and carriable weight. It also simulates the folding and carriability of the vehicle as shown.

The following basic dimensions were arrived at from the mockup.

### Head Tube Angle

Head tube angle is the angle between the floor behind the front wheel and the steering axis. It defines the rake angle. The head tube angle for our concept is taken as 74 degree which is the general head tube angle in cycles.

### Wheel size

The wheel size used in the mock up is of 14 inch diameter. This will be reduced to 12 inches dia wheel to make it more compact still maintaining the minimum ground clearance of 10 cm.

### Handle height

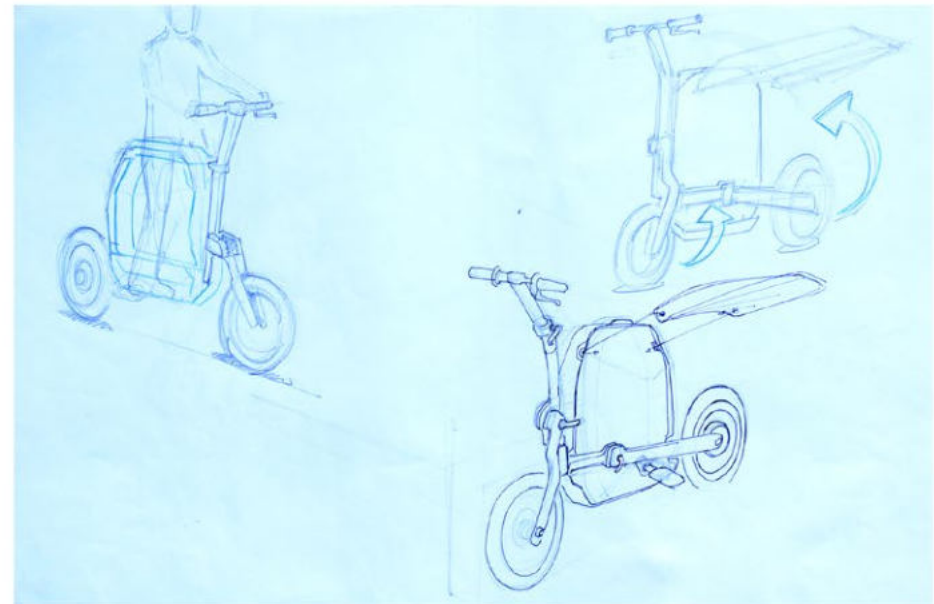
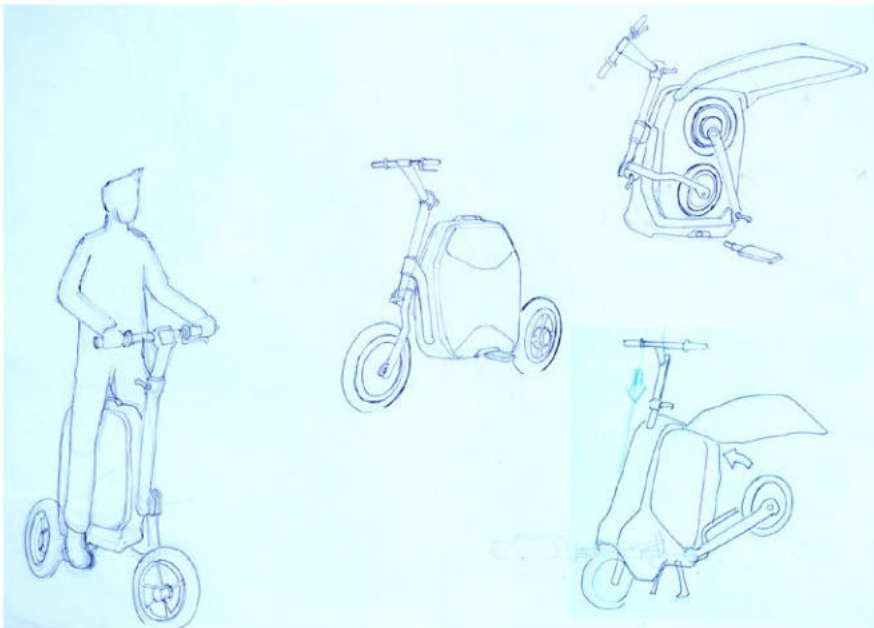
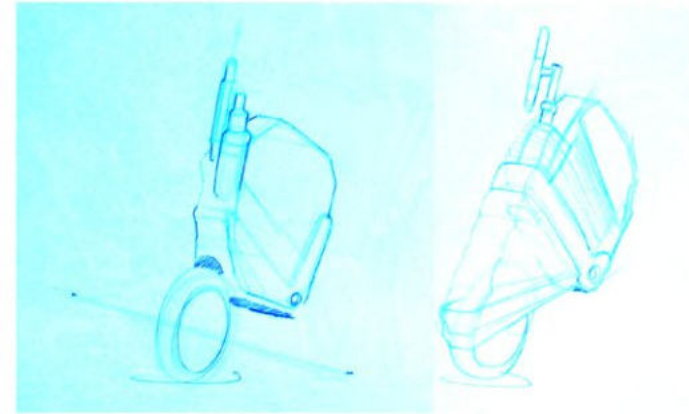
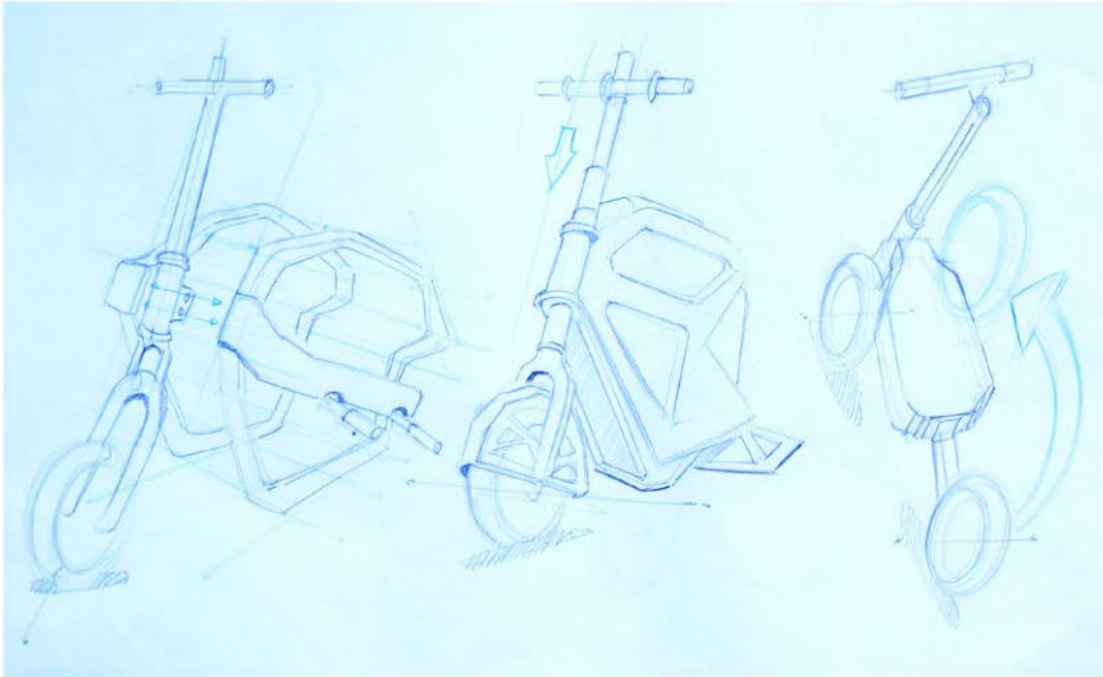
Handle height is fixed based on a standing riding posture. It is arrived at around 900 mm. This is further checked and refined in CAD with a 95th percentile human model.

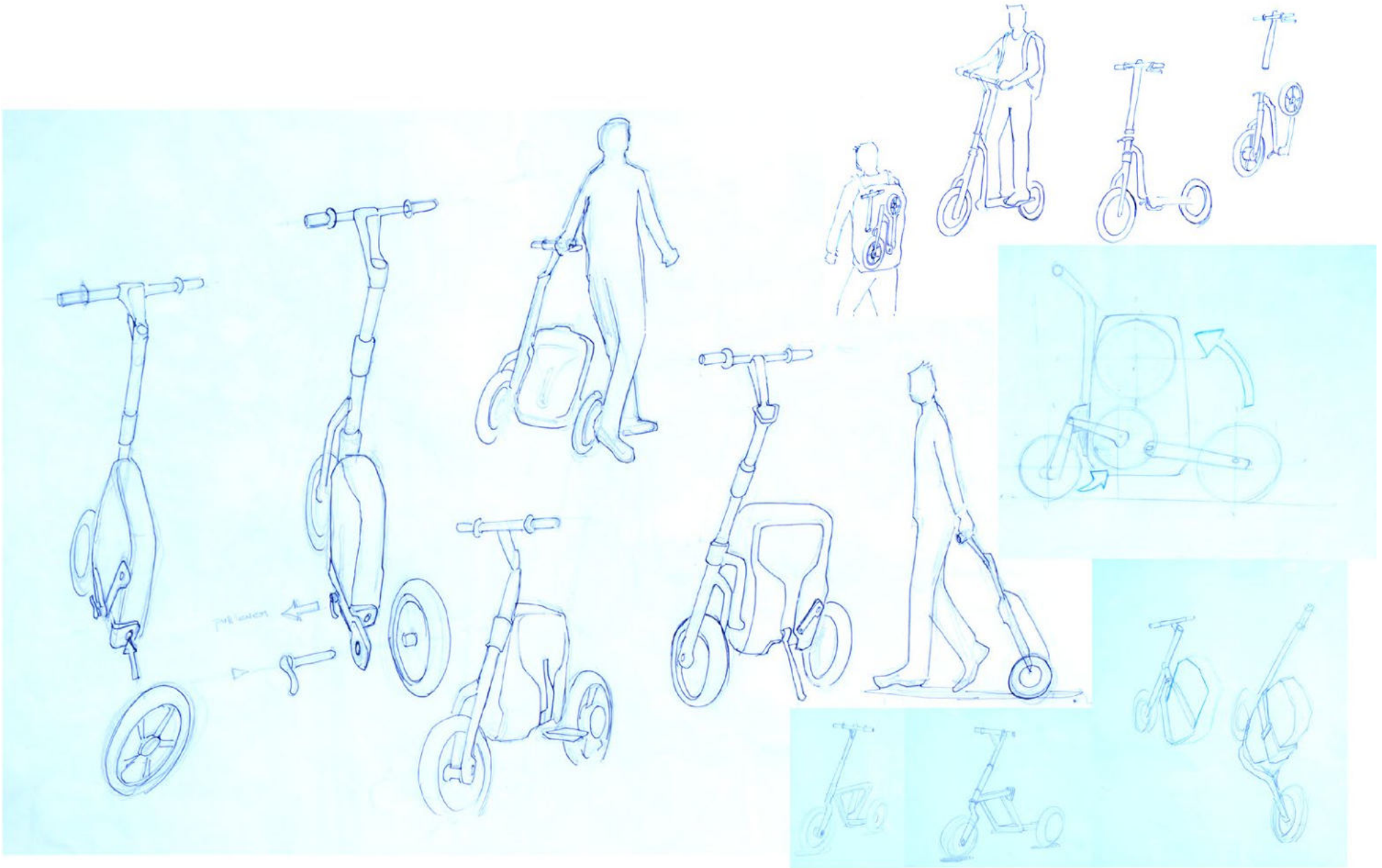


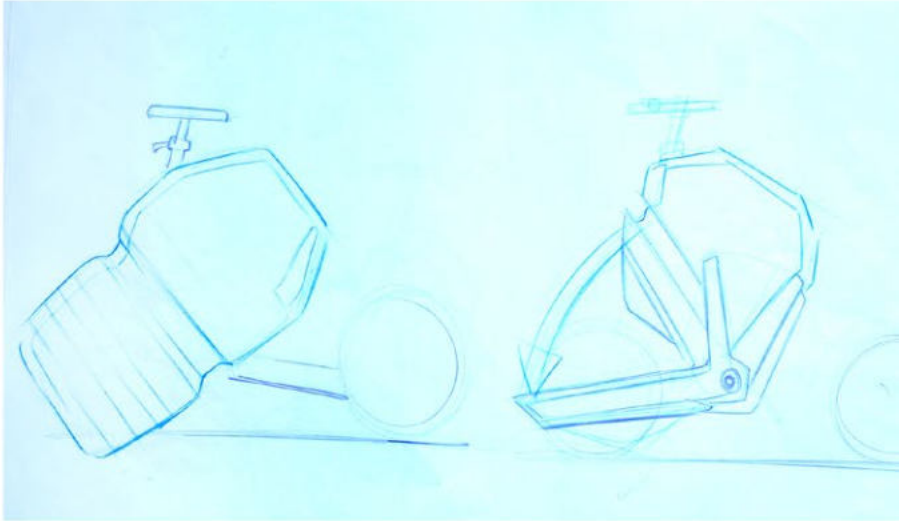
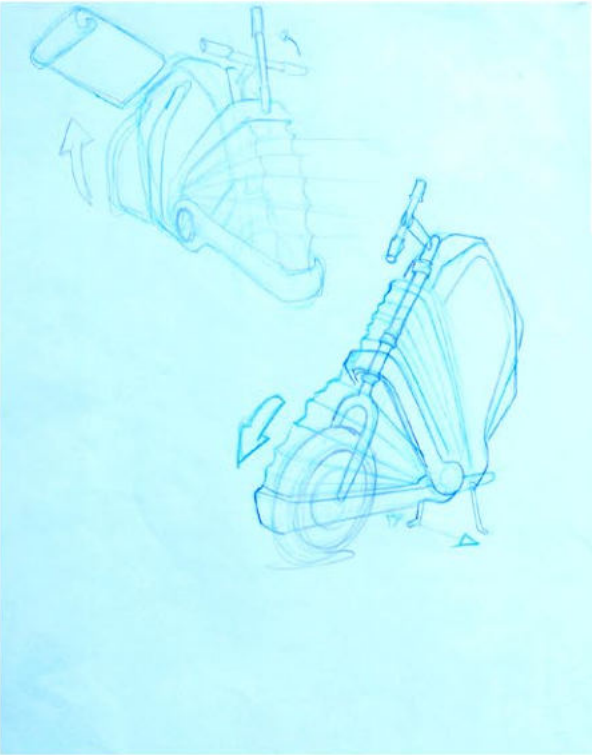
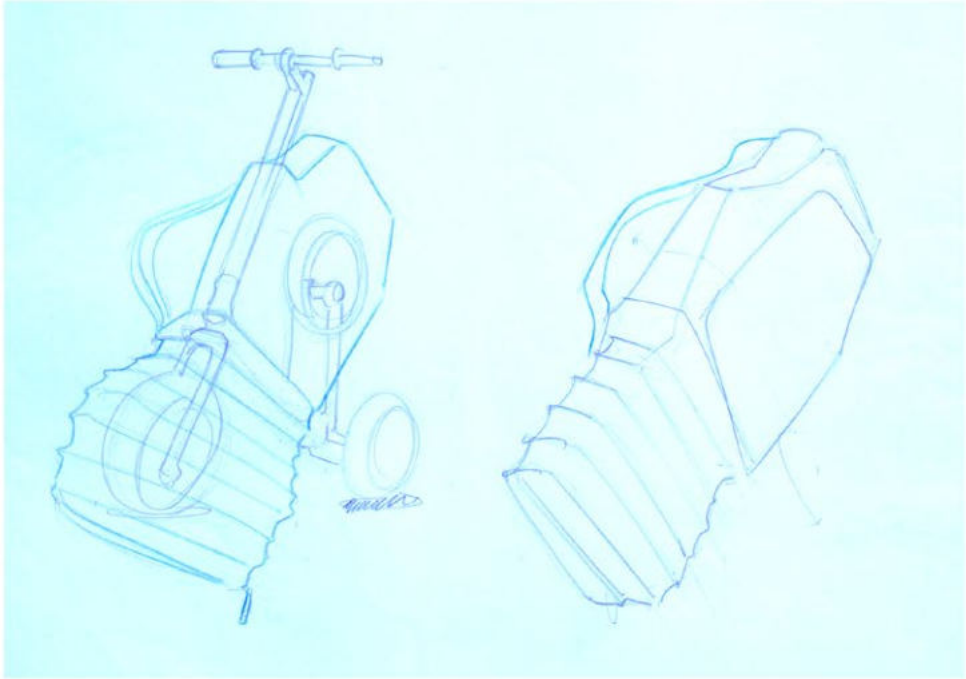
The following folding sequence is enacted from the mockup. It is found that having two folds in the frame is more tedious for the user. Further having a fold in the front steering hub can be avoided as it involves complexity. The major folding part is the frame fold. There are two frame folds in this concept mockup. Hence it is decided to reduce the frame folding to one. Further concepts were explored with minimal folding requirement.



# FOLDING CONCEPT EXPLORATION SKETCHES







# FINAL CONCEPTS



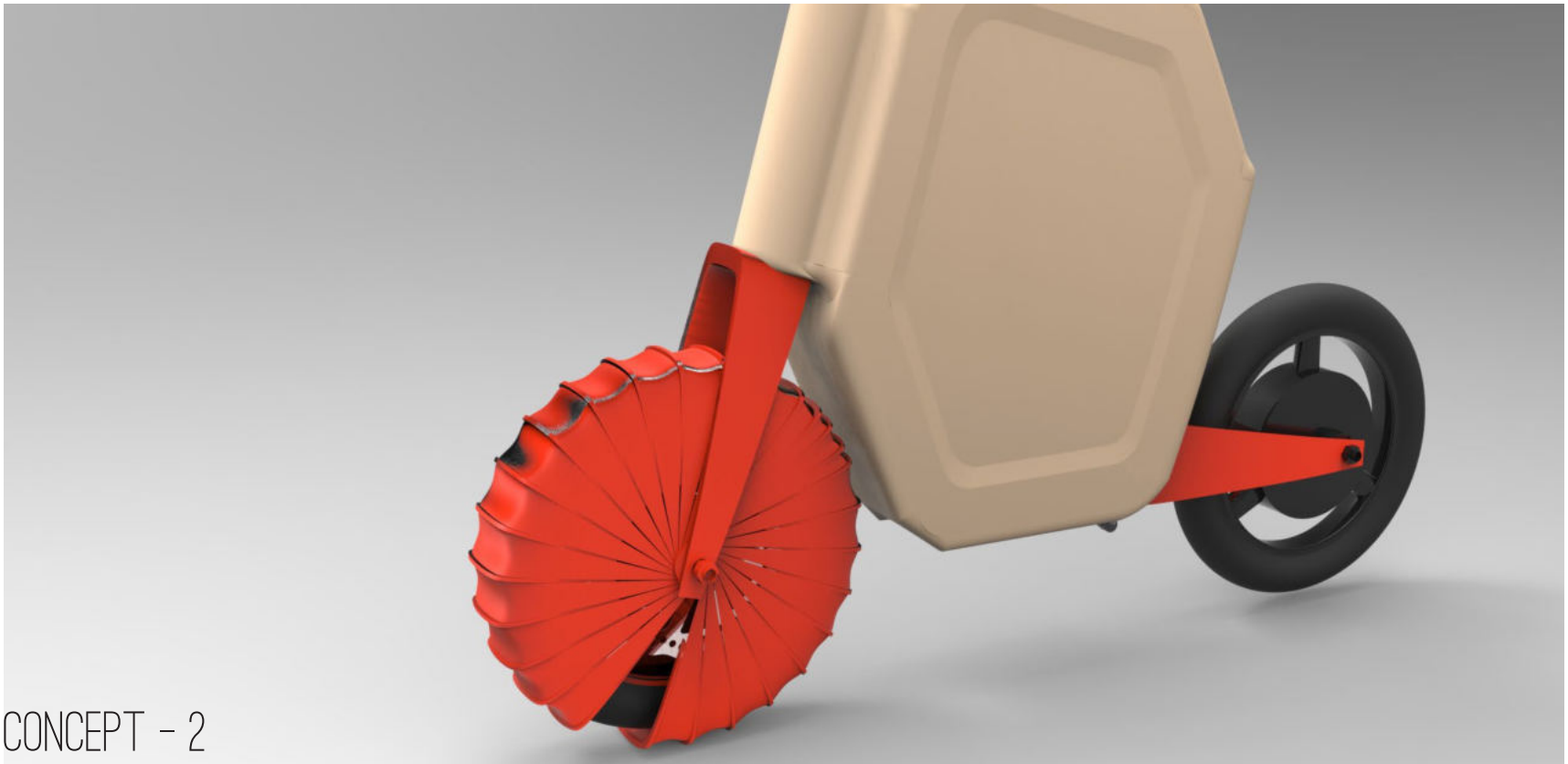
CONCEPT - 1

Concept 1 is an electric bike which can be pulled along like a suitcase when it's not being used for riding. The case also can house luggage along with the integrated frame. When it has to be used for transportation, the front steering and the rear wheel has to be re-oriented .



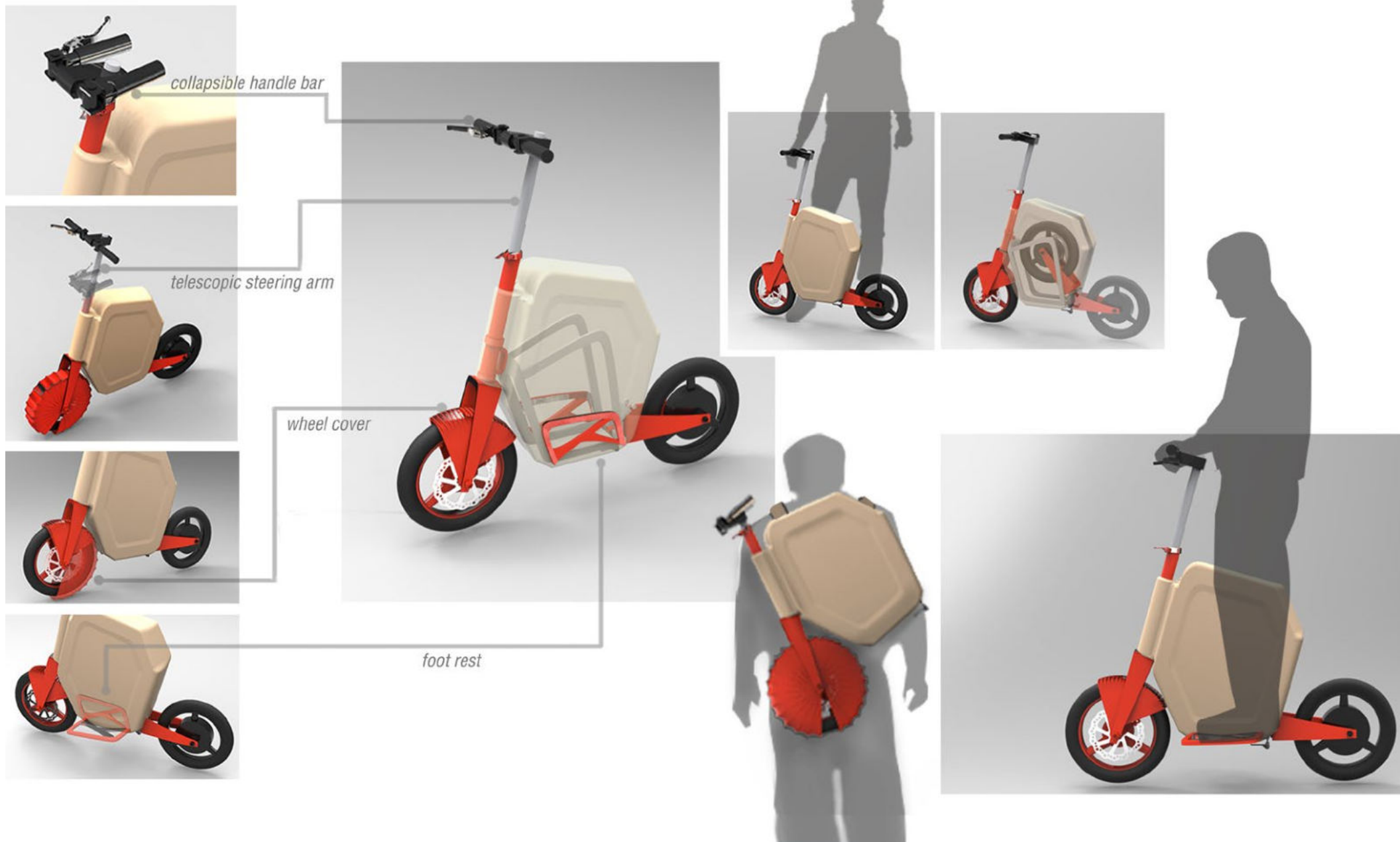
folding foot rest





## CONCEPT - 2

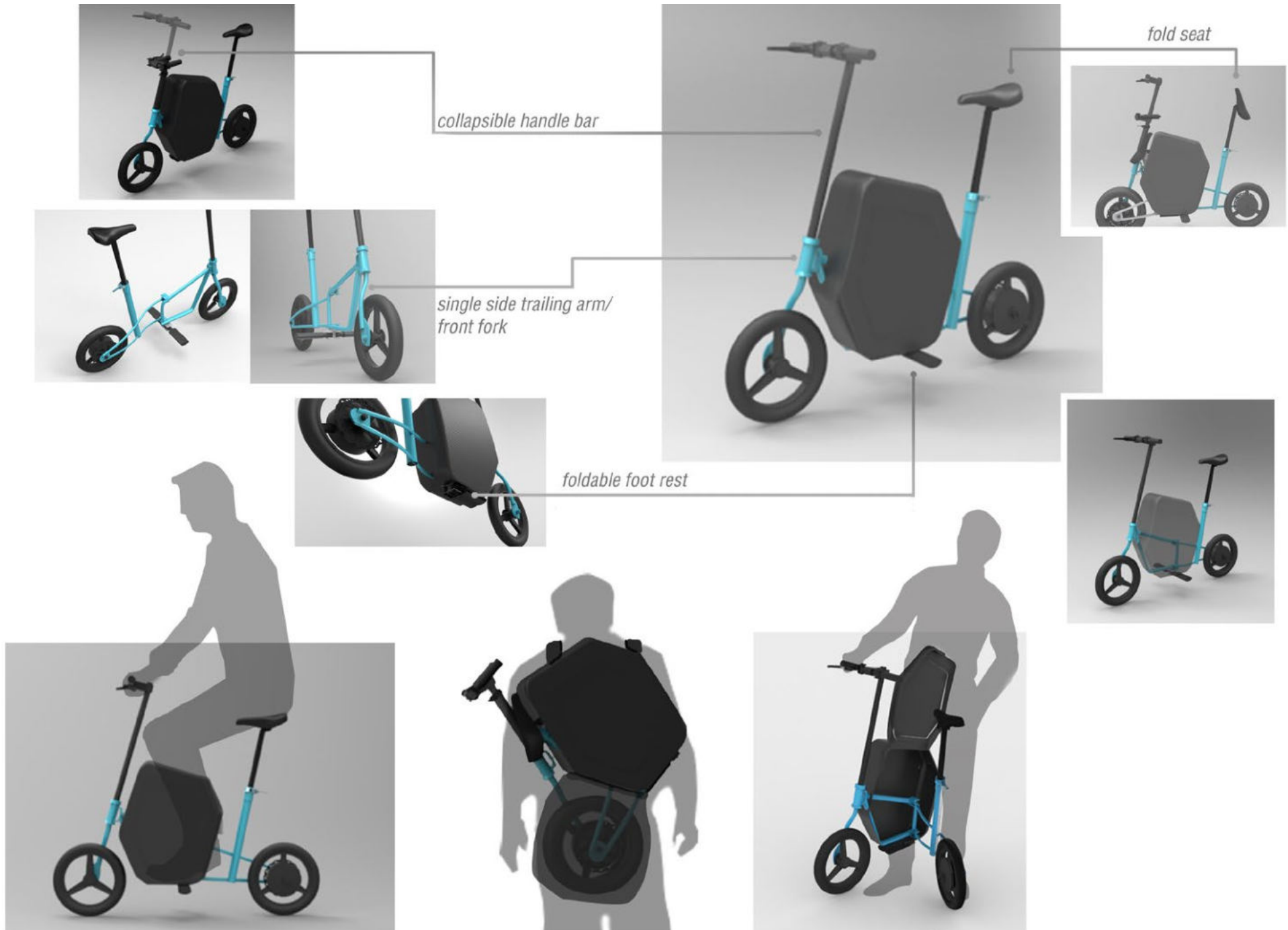
Concept 2 is an electric bike which involves central frame folding. After folding it converts into a backpack which can be carried along when not in use. The front wheel is covered using a retractable guard which also can act as a wheel flap.





CONCEPT - 3

Concept 3 is similar to concept 2 except the bike has a lateral folding which is similar to many compact folding bikes. Lateral folding reduces the user effort. Also it has a sitting posture which is more comfortable and reduces the need for bigger footrest.





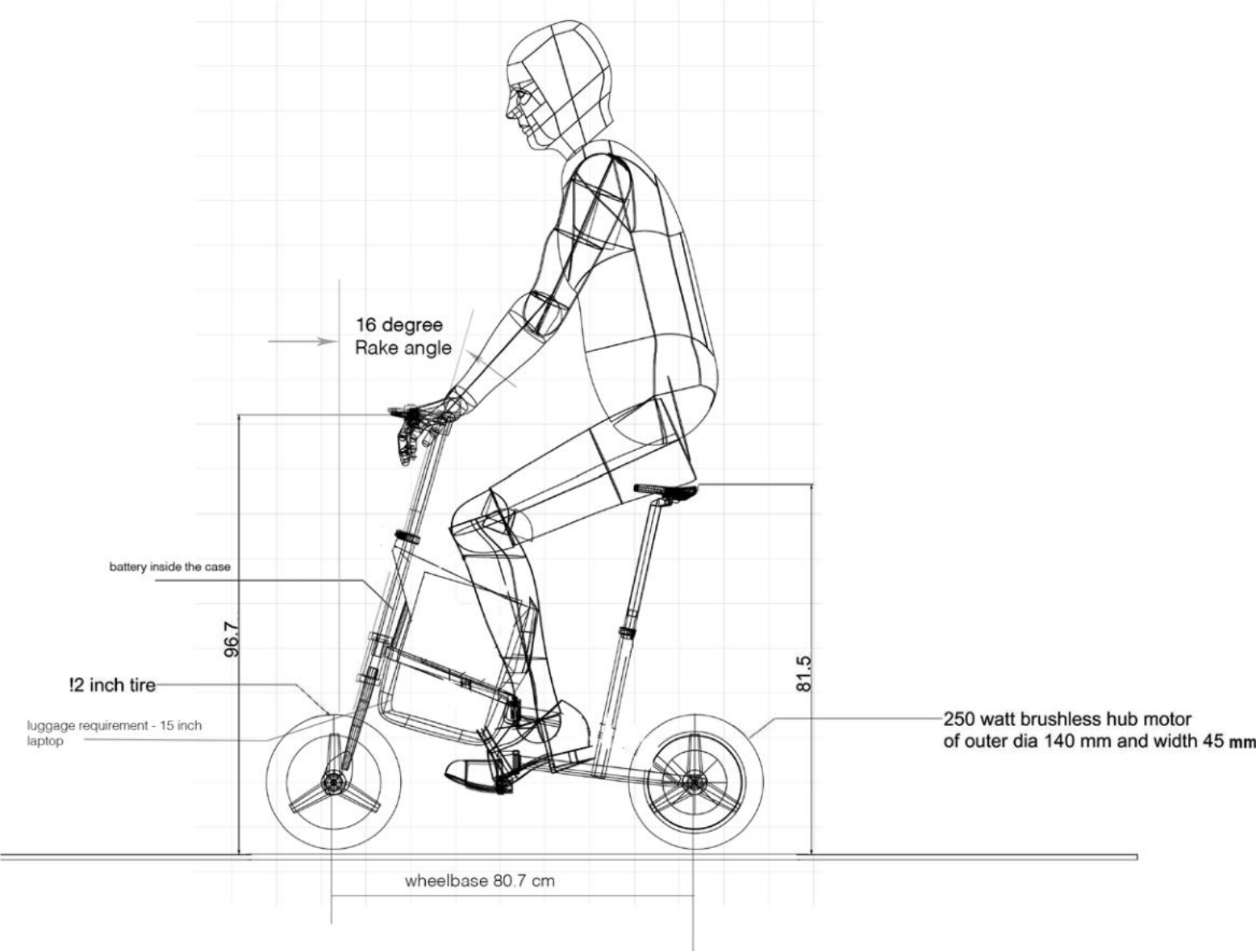
Of the three concepts, concept 3 is taken for further exploration and detailing as it has lateral folding which is easier for the user to folding. The user need not bend much incase of lateral fold and the effort involved is lesser compared to tother concepts. Concept 3 also has a sitting posture which makes the user comfortable to ride.

# SITTING POSTURE

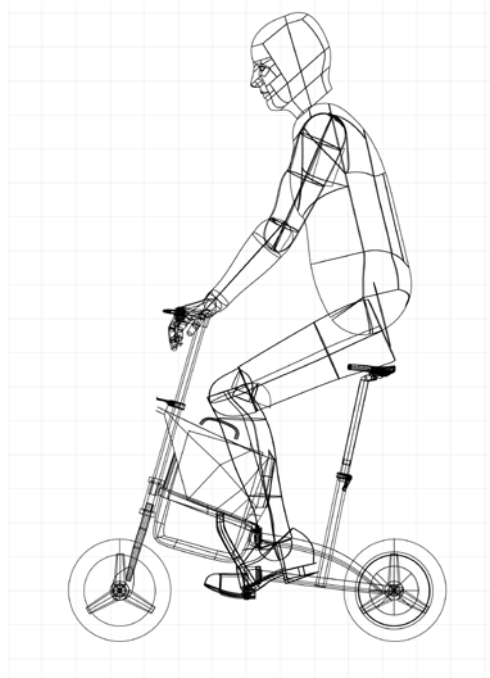
To study the sitting posture, a rig has been made using an existing BMX cycle. The seat position, handle bar position and the foot rest height is modified . The posture in the rig is then verified with different users (of around 95th percentile and average 50th percentile) at different seat height and handle positions. The optimal position is used and transferred to CAD. The seat height is brought down to make the cycle compact and the handle position is adjusted accordingly. This is then verified in the rig.



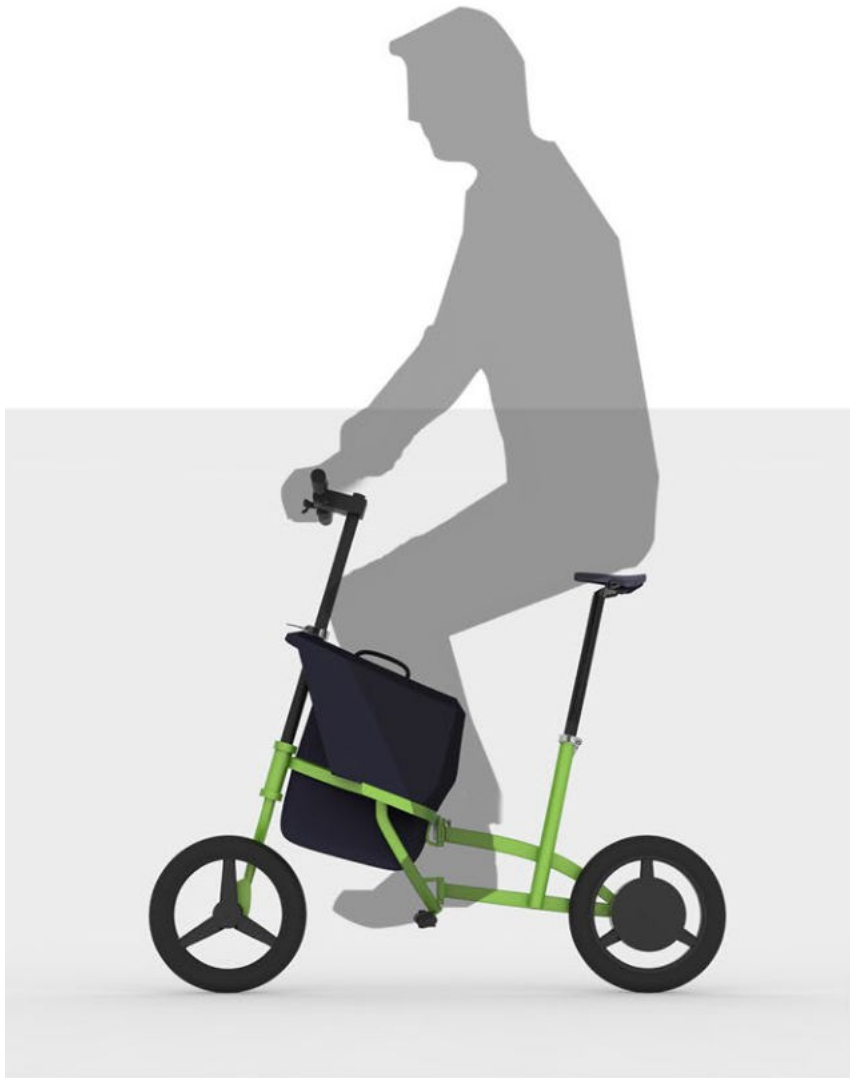
The final sitting posture is referenced in CAD along with the technical constraints of luggage space, wheel base, seat and handle bar position, wheel size and wheelbase required to accomodate riding in sitting posture. Also a minimum ground clearance of 10 cm is required and hence the choice of 12 inch wheel is opted for. Further, the laptop volume should be accomodated inside the pack.



## FINAL CONCEPT

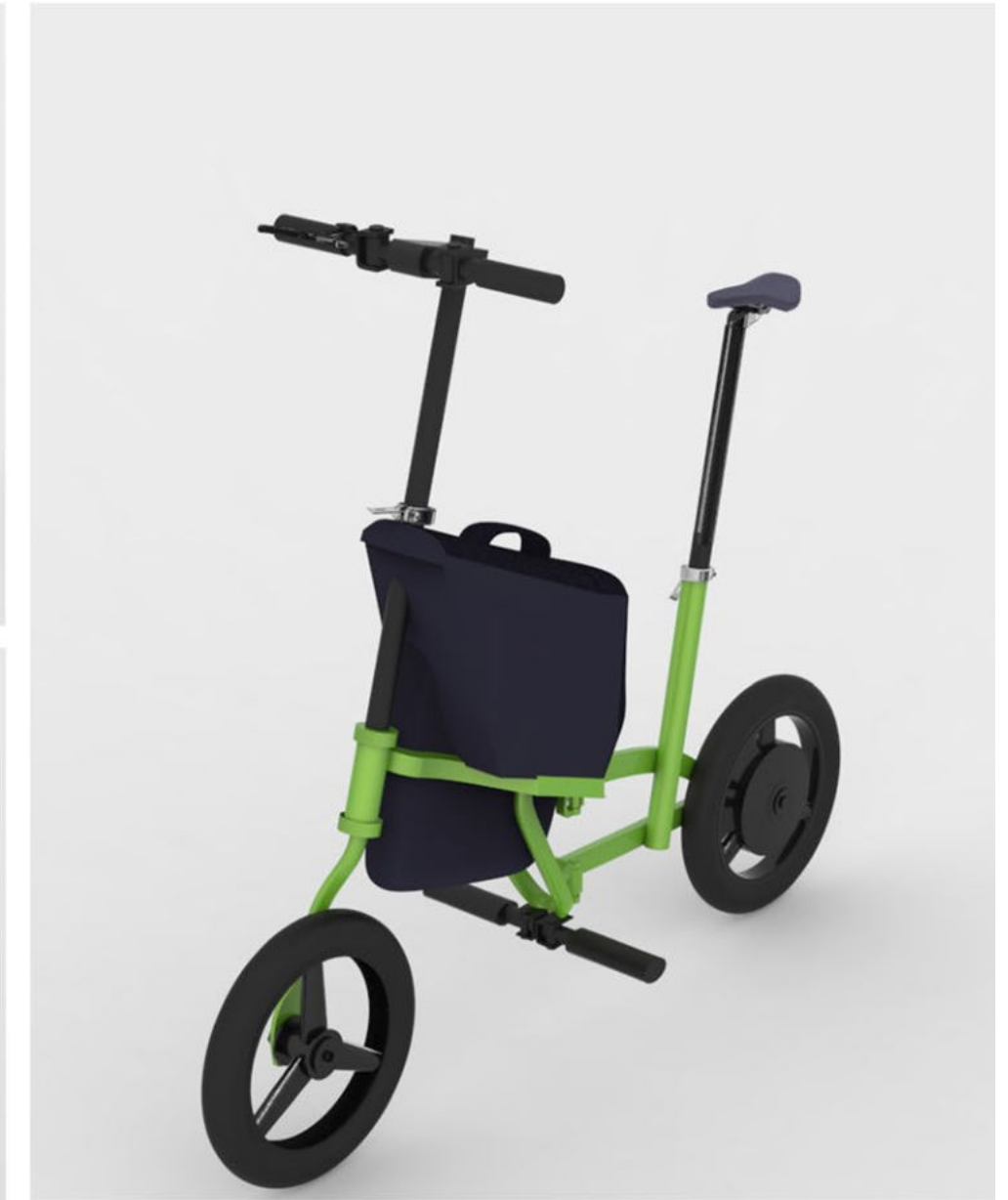


Based on the rig data for sitting posture and concept 3 , the final concept with detailing of the bag is arrived at. The given constraints of wheel size, rake angle, luggage space, backpack requirements, seat height were taken into account and the final design CAD is made.





*laptop case*



# FOLDING SEQUENCE



*seat height down and foot rest fold*

*lateral fold*

*handle bar fold and down*

wheel cover roll

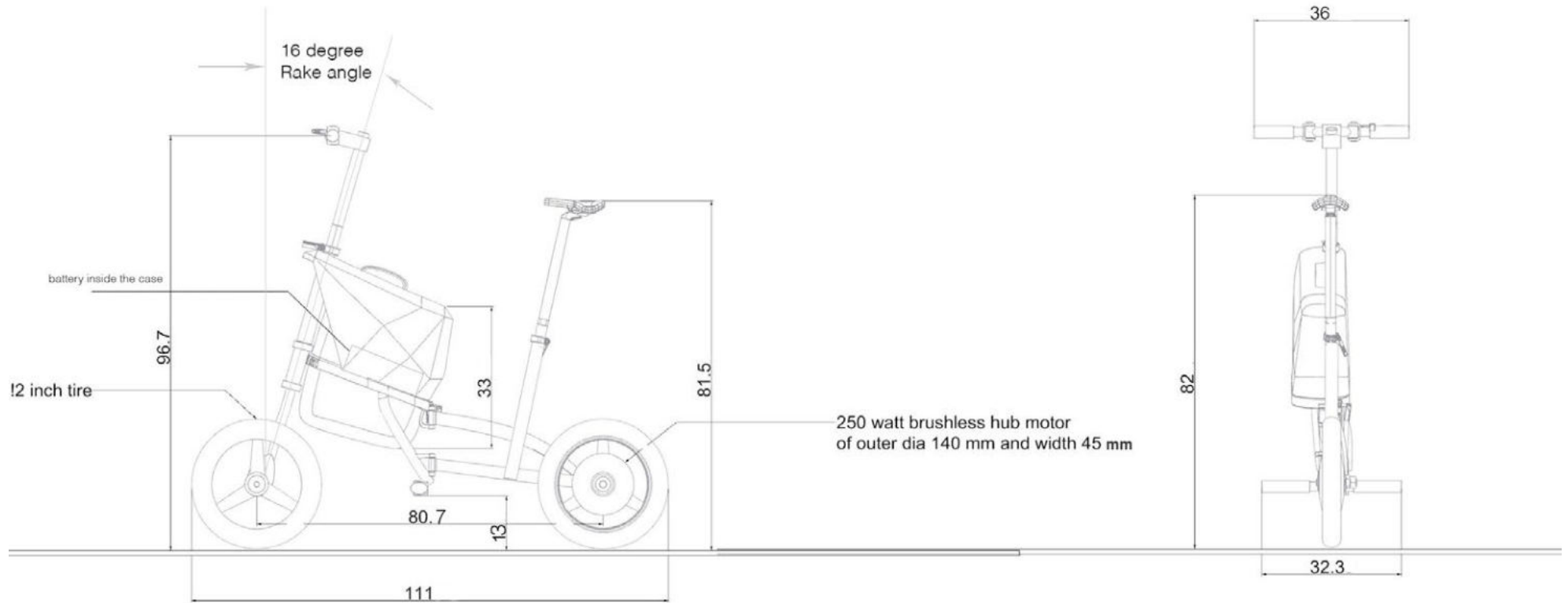


*pull out sack and zip it*

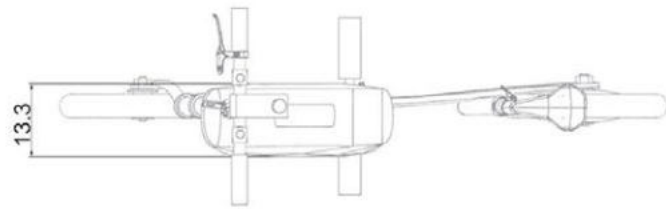


image source - <http://handsonbike.blogspot.in/2011/12/part-8-cheap-bikes-vs-premium-bikes.html>

# CAD DRAWING



all dimensions are in cm unless otherwise specified



## PHYSICAL MODEL

A 1:1 scaled physical model is made to check the posture, foldability and car-riability. The model is made from steel tubes and hence the actual probable weight data can also be found.





# REFERENCES

References are given in the same page wherever it is used. Further references are taken from the following sources

- Velo: Bicycle Culture and Design by Robert Klanten
- The Bike Book Lifestyle. Passion. Design. by Te Neues
- Velo—2nd Gear: Bicycle Culture and Style by Sven Ehmann and Robert Klanten
- The Electric Bike Book by Jim Turner

