



Project III:

WASTE MANAGEMENT

IN MUMBAI

Avinash Jayakumar
126132001
Guide: **Prof. Purba Joshi**

WASTE IN MUMBAI

- **Wet organic** includes kitchen waste, cooked food, garden waste
- **Dry organic** waste includes wood, cloth, paper
- **Recyclable** consists of plastics, metals and glass
- **Inert Material** is mainly construction debris

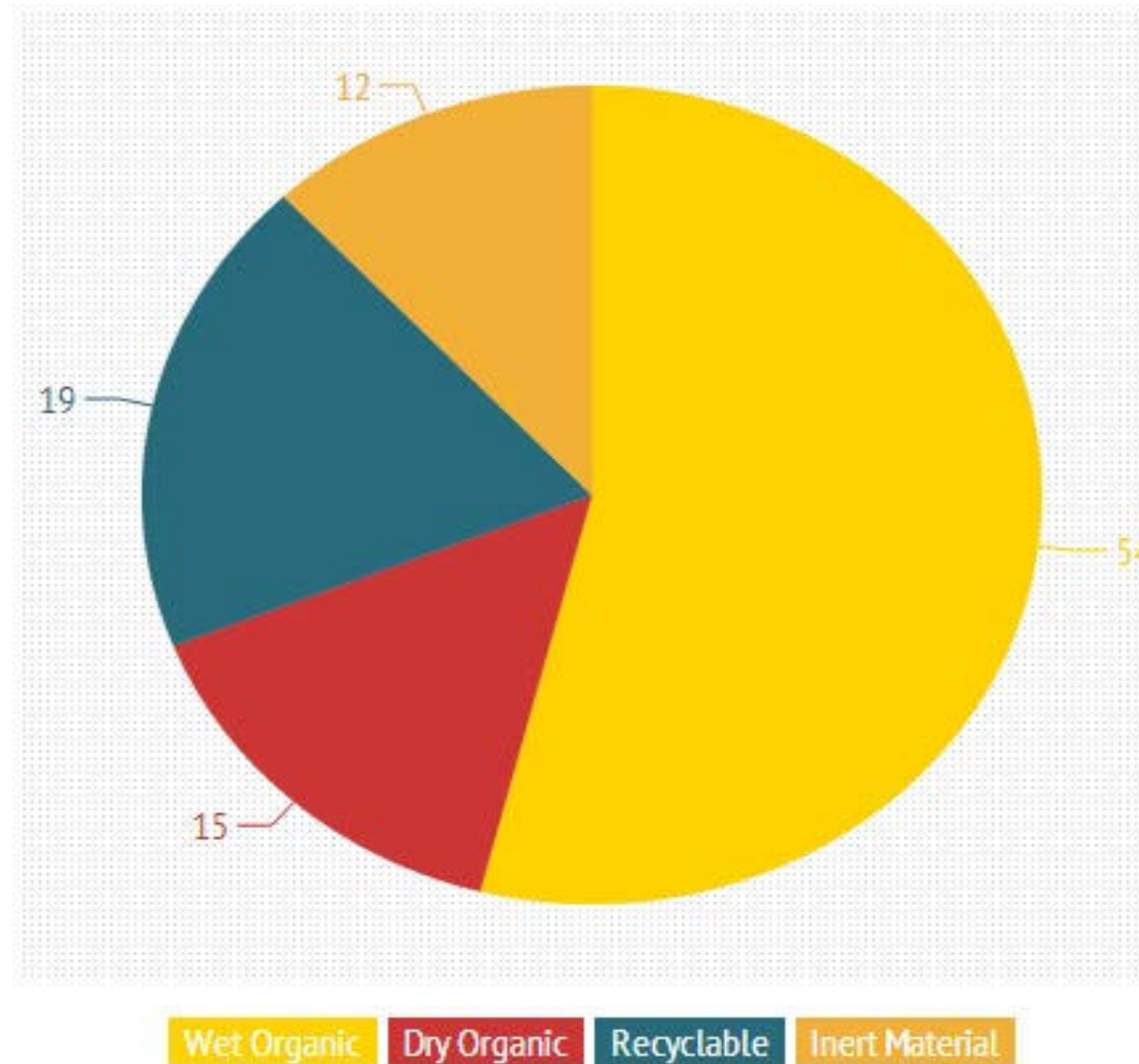

JOURNEY

OF SOLID WASTE

GENERATION

COLLECTION

SEGREGATE

TRANSPORT

RECYCLING

DUMPING

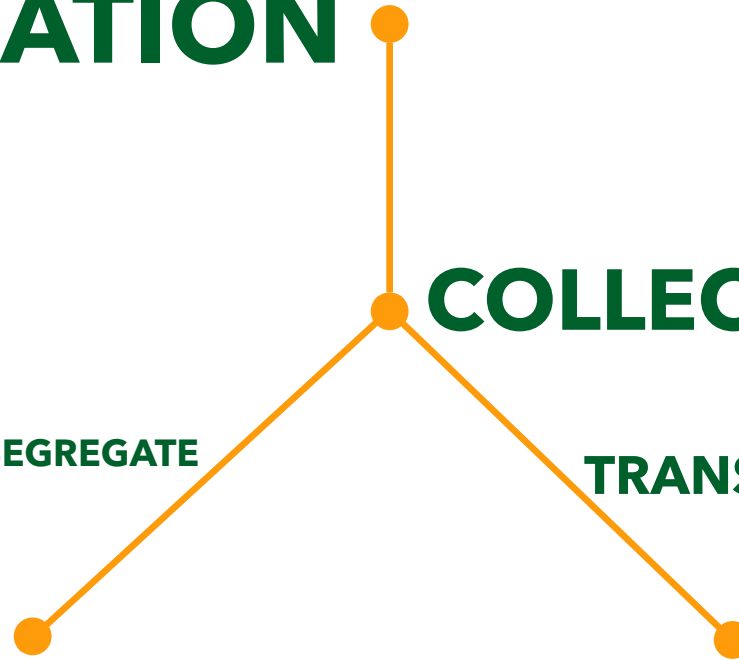

COLLECTION OF SOLID WASTE



COMMUNITY BIN



PUBLIC BIN



STREET SWEEPING



**GULLY CLEANING
(CITY AREAS)**

COLLECTION OF SOLID WASTE

5800 COMMUNITY BINS ACROSS MUMBAI



1100L BINS



660L BINS



120L BINS

COLLECTION OF SOLID WASTE

PUBLIC BINS



COLLECTION OF SOLID WASTE

STREET SWEEPING



1. SWEEPING



2. PILING UP



3. SCOOPING



4. GATHERING



5. TRANSPORTING



6. DUMPING

COLLECTION OF SOLID WASTE

GULLY CLEANING (CITY AREAS)



1. MARKET SHOPS



2. DRINKING WATER PIPES



3. HUMAN SCAVENGERS



4. NARROW GAPS



5. PILE DURING COLLECTION

TRANSPORTATION OF SOLID WASTE



1. MANUALLY



2. SMALL TRUCKS



3. MOBILE COMPACTORS

DUMPING OF SOLID WASTE

- **95%** of waste transported here
- Oozes **Leachate**
- Creates **methane gas**
- **3 MW** power plant at **Nashik**



1. GORAI

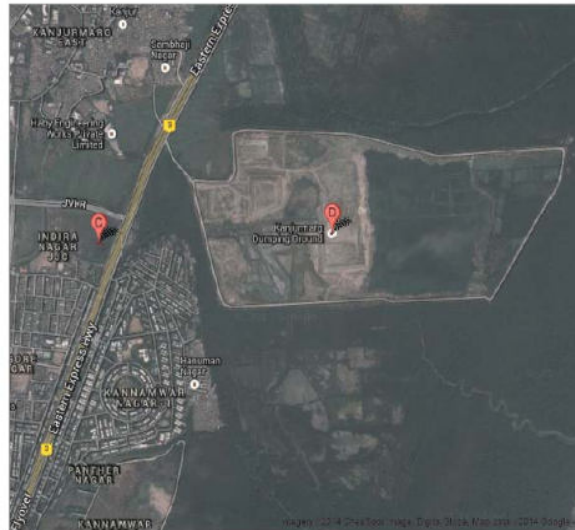

2. KANJURMARG



3. MULUND

DUMPING OF SOLID WASTE



DUMPING OF SOLID WASTE



DUMPING OF SOLID WASTE



DUMPING OF SOLID WASTE



SEGREGATION OF SOLID WASTE

- Rag-pickers collect recyclables
- Post-collection given to middle-men
- Inefficient, unhygienic and de-humanising method
- Spill contents of garbage bins on street to pick



RECYCLING OF SOLID WASTE

DHARAVI



PROJECT FOCUS

REDUCE

LANDFILL WASTE

- Unsegregated garbage causes severe problems:



- Lack of space
- High cost to taxpayer
- Unsustainable method of “pick-and-dump”
- Waste of recoverable resources

IMPROVE LIVING

- Street Level Waste Collection
 - Promoting Segregation at source (street-level)
- Better living environment
- Reduced pests, strays
- Better health & hygiene
- Improved waste recycling, reduction of landfill waste

STRATEGY

AND APPROACH

- 1. SHIFT BALANCE OF RESPONSIBILITY**
- 2. GUIDE BEHAVIOUR THROUGH DESIGN**
- 3. EDUCATE / PUBLICIZE & MOTIVATE**
- 4. EMPOWER RAGPICKERS / RECYCLERS**
- 5. BETTER WORK ENVIRONMENT FOR HANDLERS**
- 6. IMPLEMENTABLE SOLUTION**

CHALLENGES

TO SOLVE

COMMUNITY BINS

- Extremely **heavy, difficult** to handle
- Open to **scavengers** (Cows, dogs, birds, rats, etc.)
- Open to **weather, unhygienic**
- **Theft**



CHALLENGES

TO SOLVE

PUBLIC BINS

- **Poor visibility**; lack of consistent recognizable presence
- Does not encourage **segregation of waste**
- Inadequate numbers, poor placement leading to disuse
- Requires contact with bin while using



DESIGN

BRIEF

Design and build a waste collection system for public areas that:

1. Promotes hygienic deposition of waste by **providing a designated area, that is easier to use** (litter causes litter, reduce scavengers & pests)
2. Encourages **dry and wet waste segregation** (through awareness, incentives, etc.)
3. Is **simple to use, service & maintain** (better working conditions, more efficient collection)
4. Creates **awareness** about proper waste disposal

FOREIGN APPROACHES

EXISTING SOLUTIONS



Japan



Europe (Made in India)



USA



Canada



North America



Italy

EXISTING SOLUTIONS

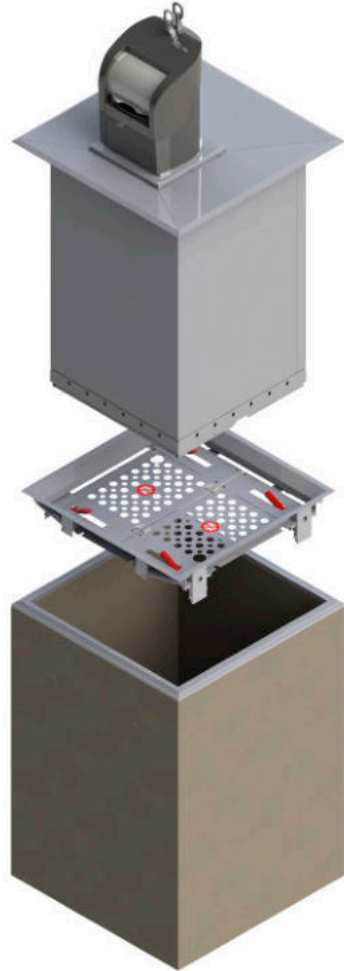

UNDERGROUND



IDEATION

IDEATION

APPROACH

INTERFACE

spitting
advertising
transparent
signage
wire-mesh
distant
throwing
street-lighting
access
interface
non-contact

STORAGE

bag control
storage
handling
palletizing
cloth
drainage
removal
jute
bin
Underground
metal
moving
plastic water
Govt. Issued

IDEATION

INTERFACES

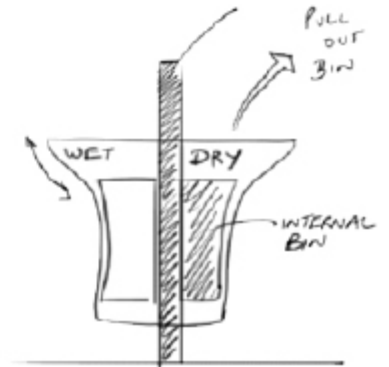
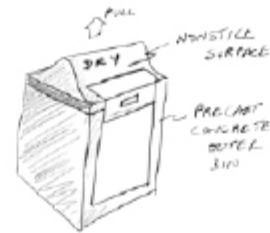
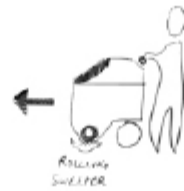
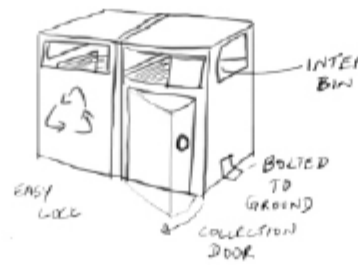

IDEATION

STORAGE

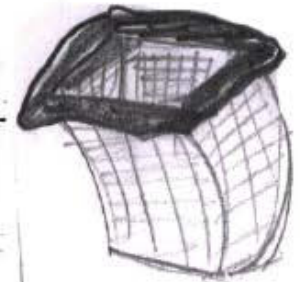
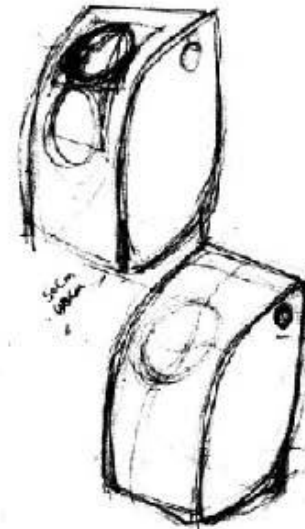
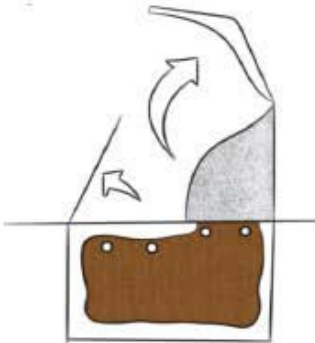
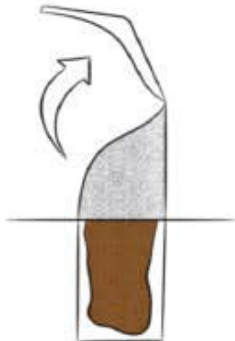
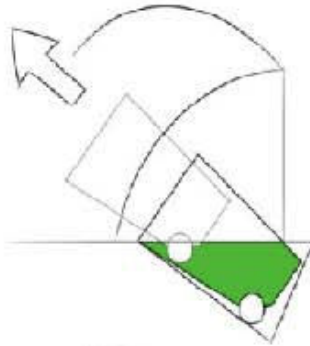
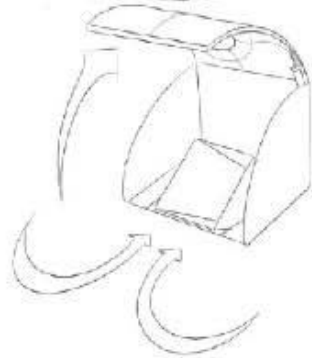

IDEATION

STORAGE

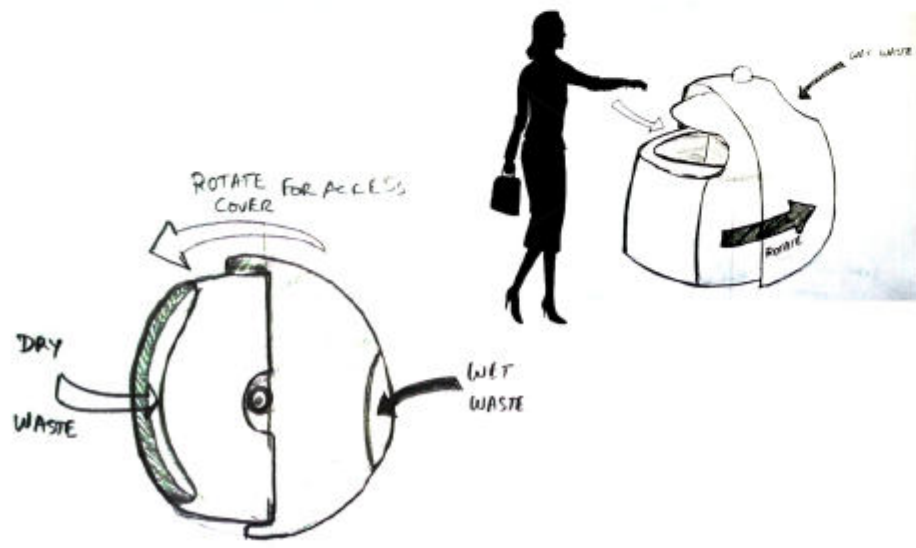
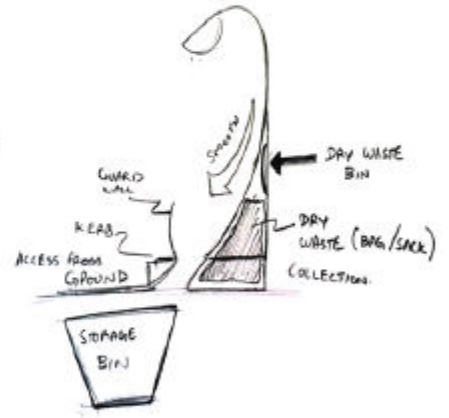
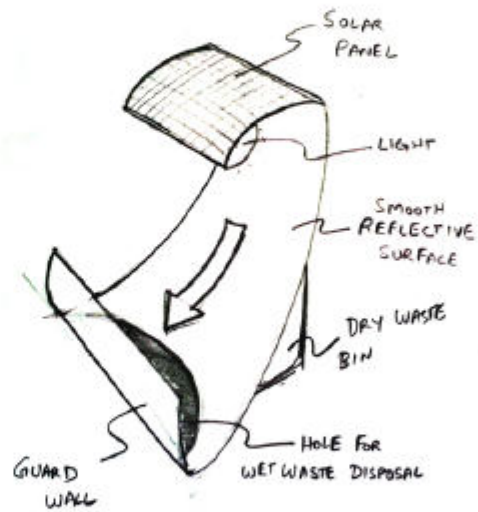
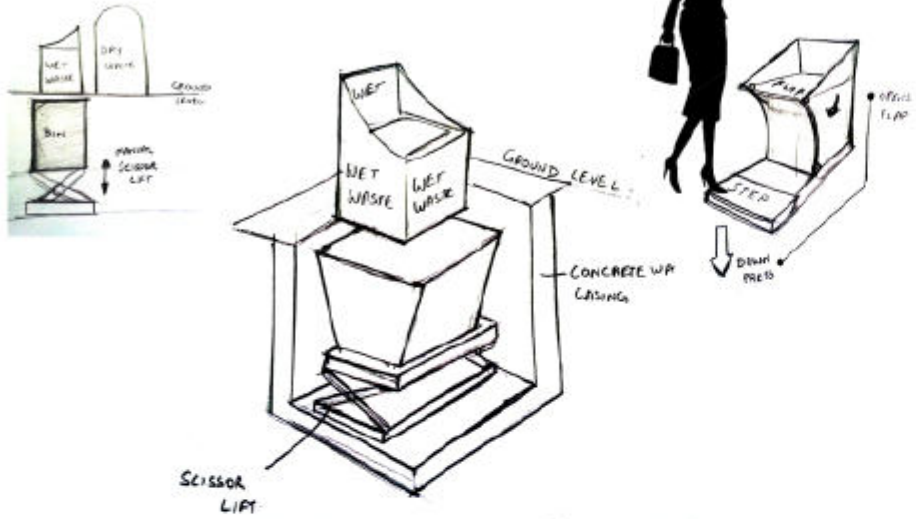

CONCEPT DEVELOPMENT

CONCEPT 1

UNDERGROUND STORAGE



Step 1



Step 2

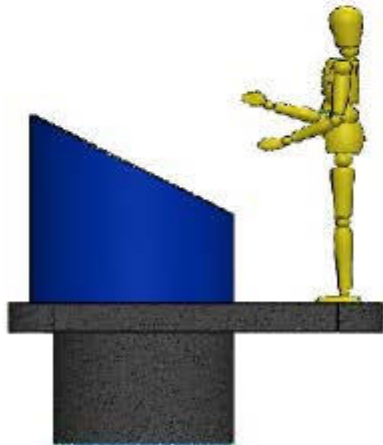

Step 3

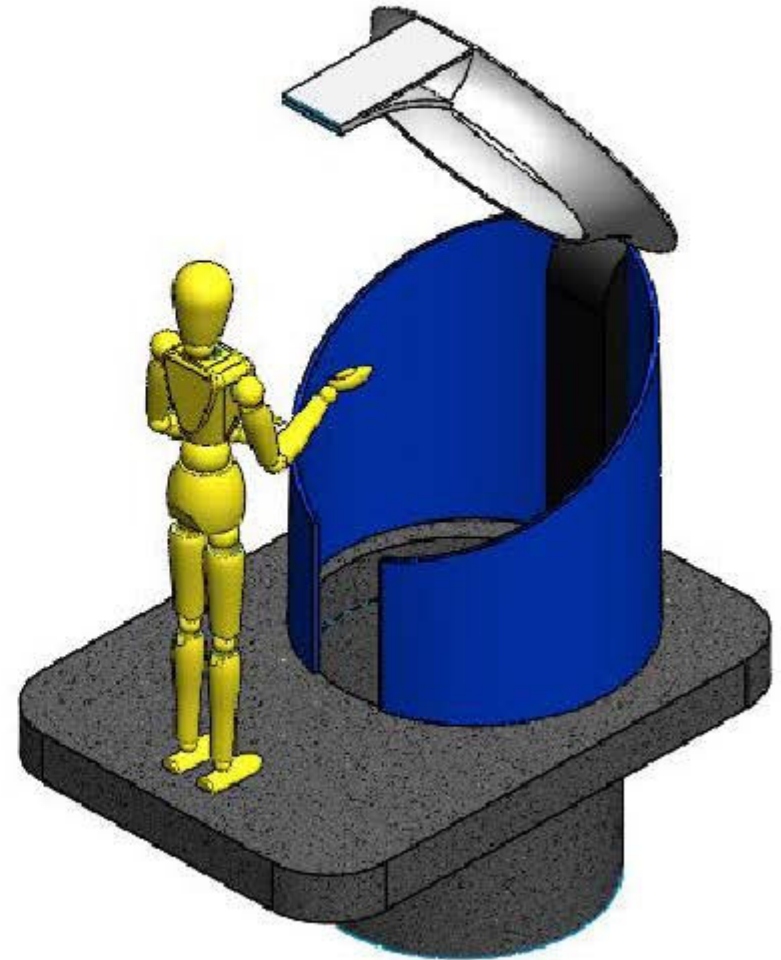

CONCEPT 1

UNDERGROUND STORAGE

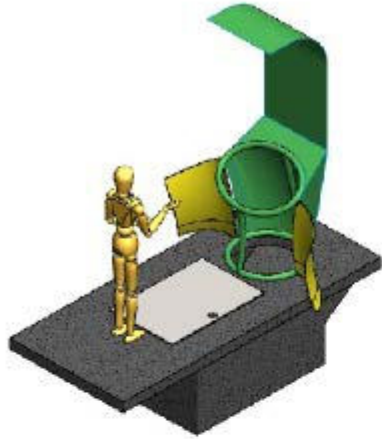

Step 1

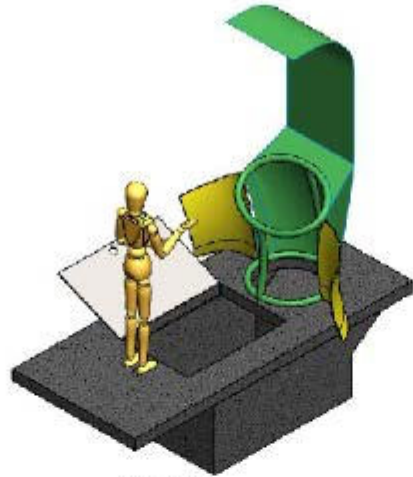

Step 2

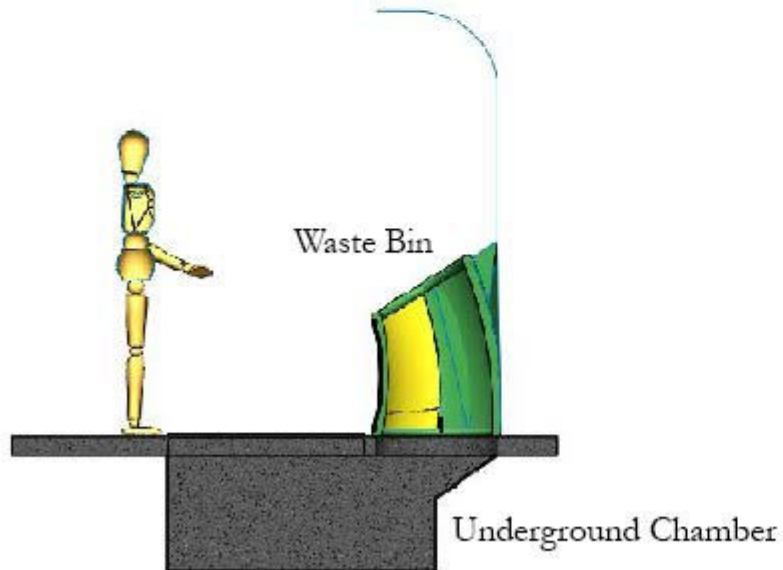

CONCEPT 1

UNDERGROUND STORAGE



Step 1

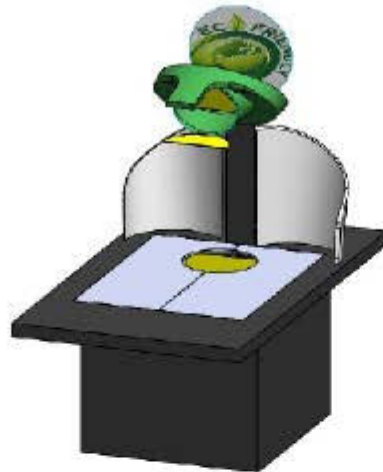

Step 2



Step 3

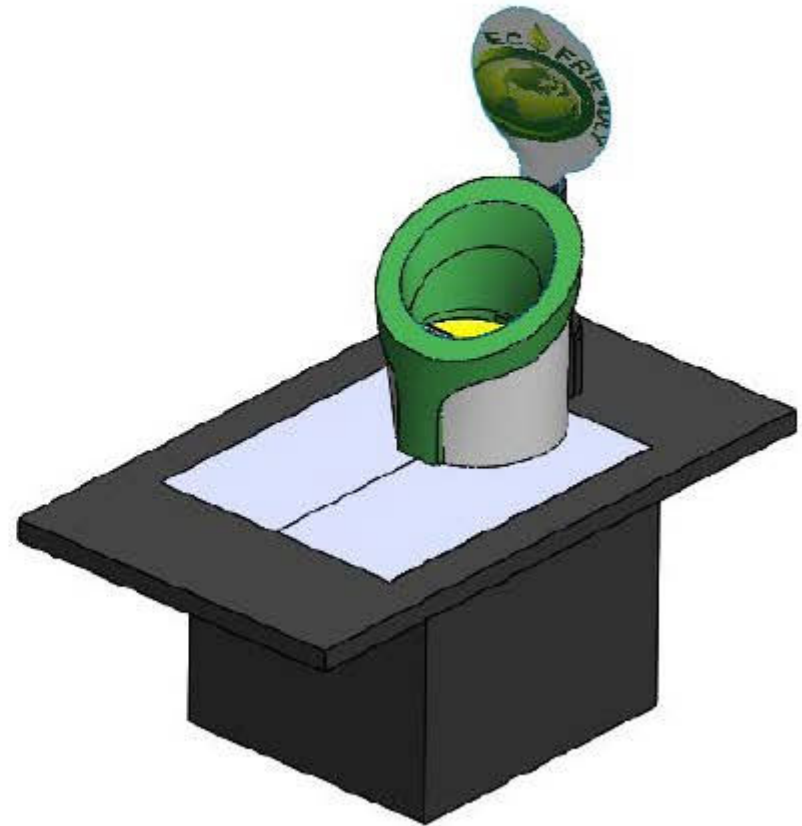

CONCEPT 1

UNDERGROUND STORAGE

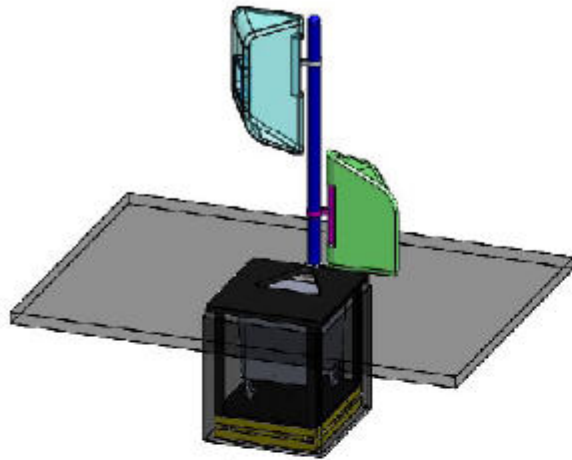

Step 1

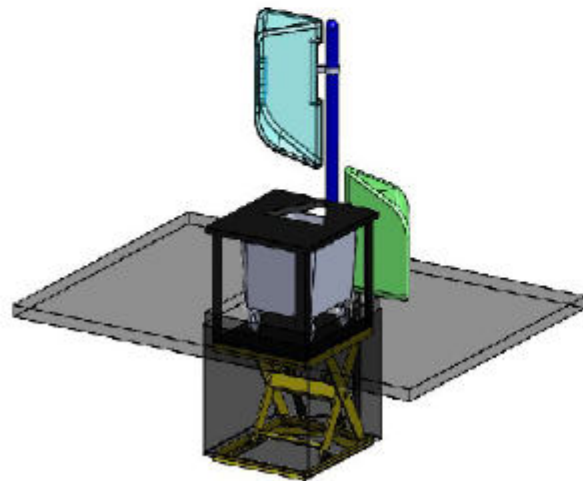

Step 2

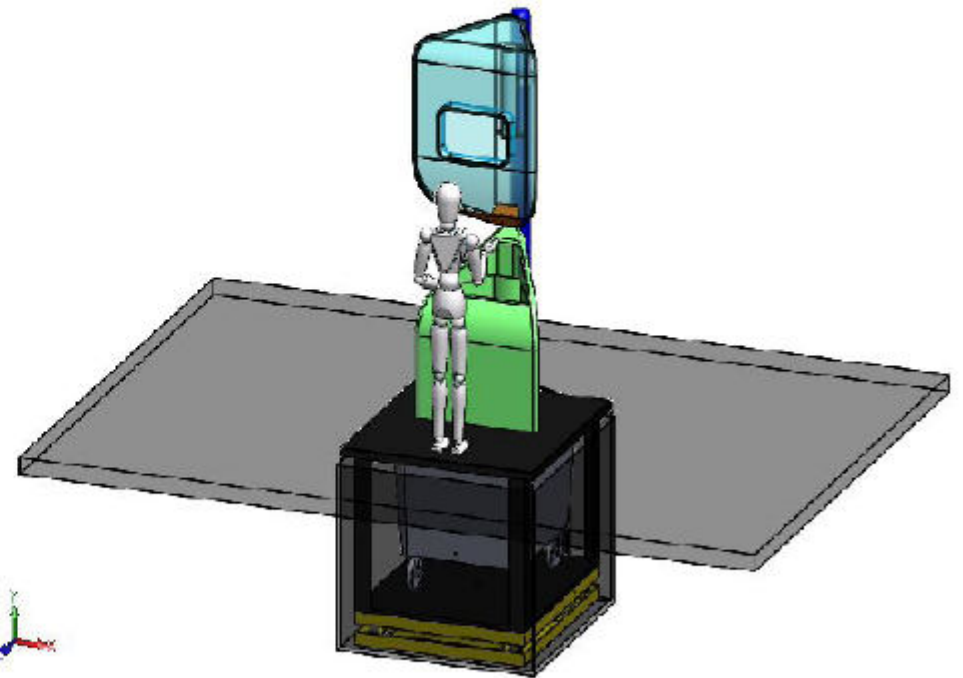

CONCEPT 1 FINAL

UNDERGROUND STORAGE

Step 1



Step 2

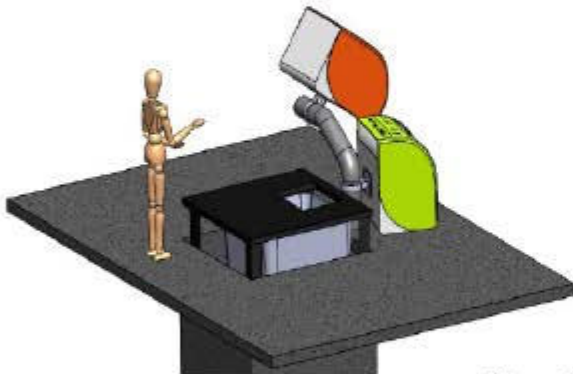

Step 3

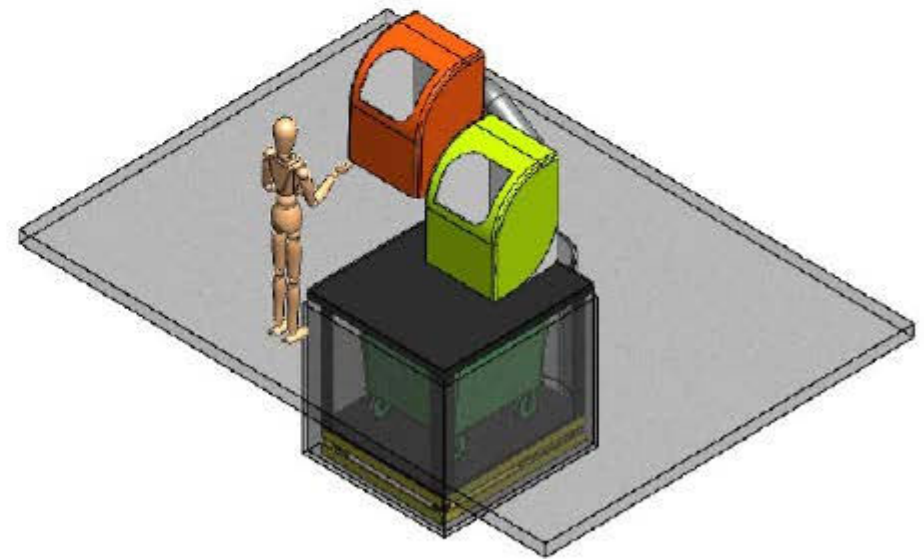
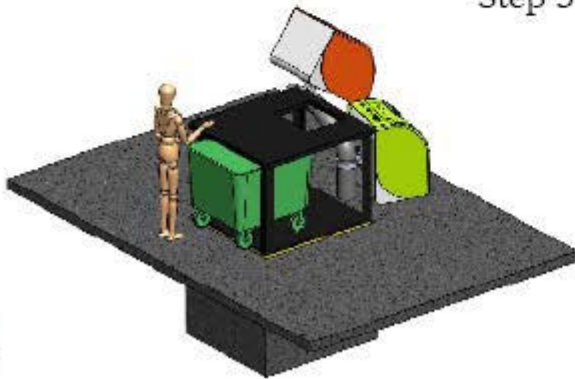

CONCEPT 2

SMALLER CAPACITY STORAGE

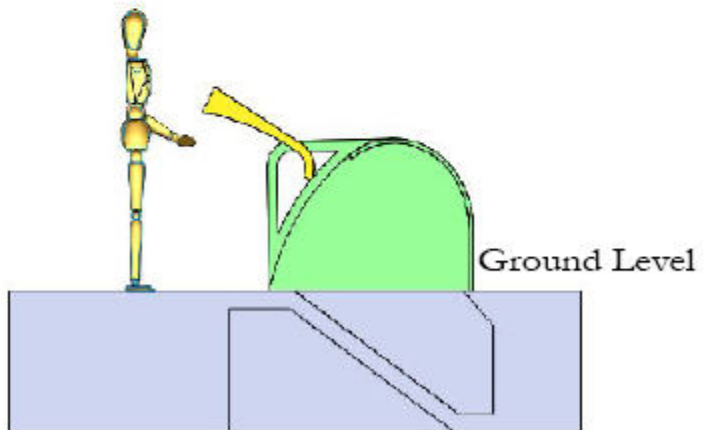
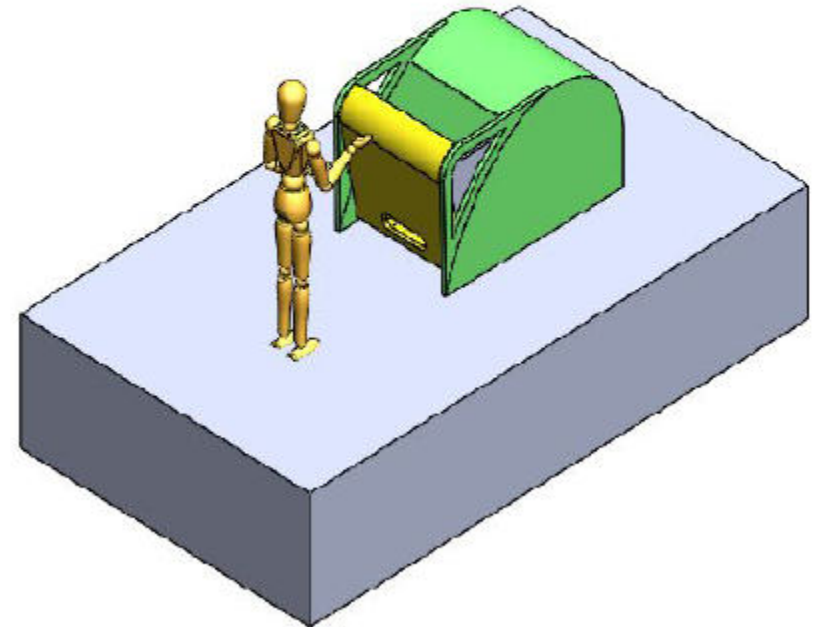
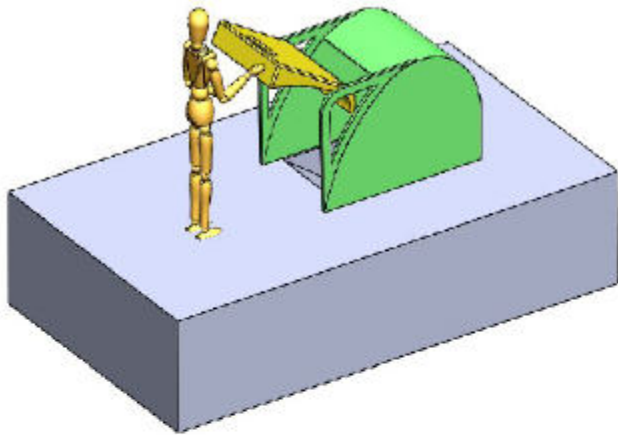

CONCEPT 2

SMALLER CAPACITY STORAGE

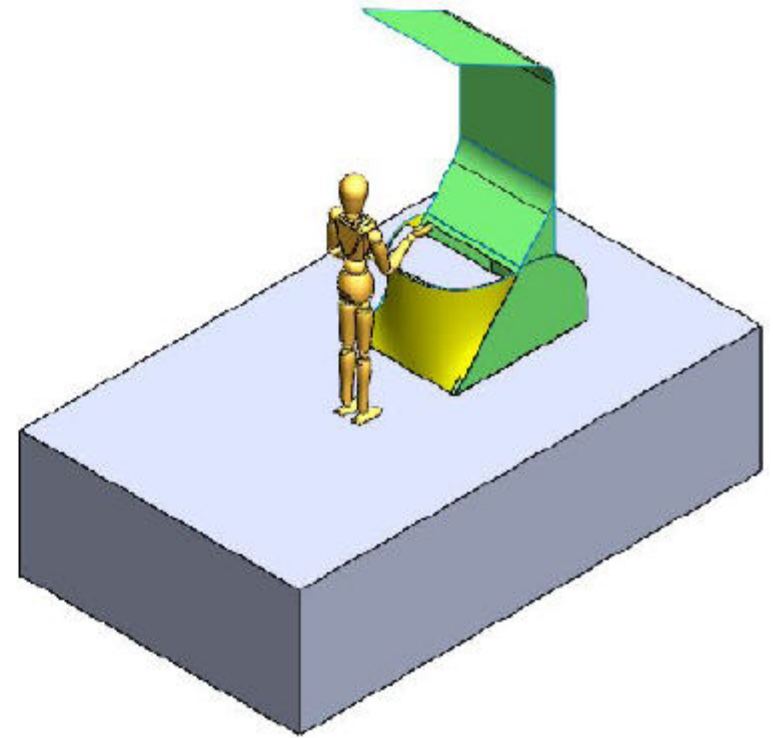
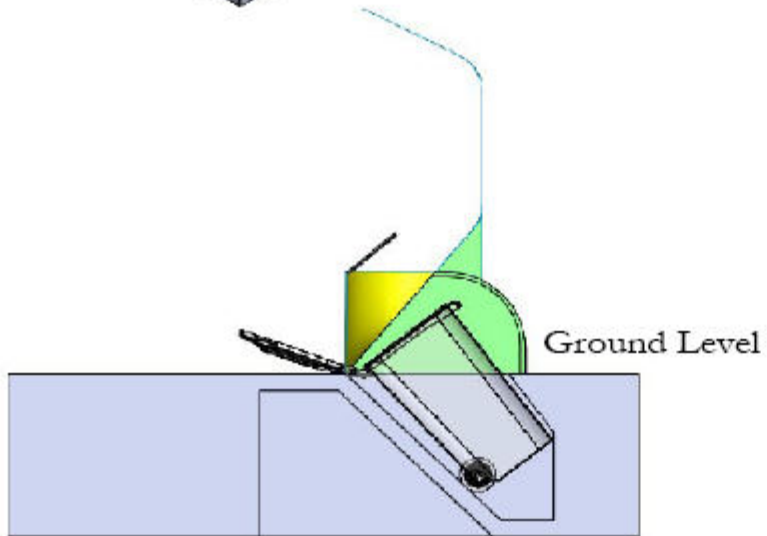
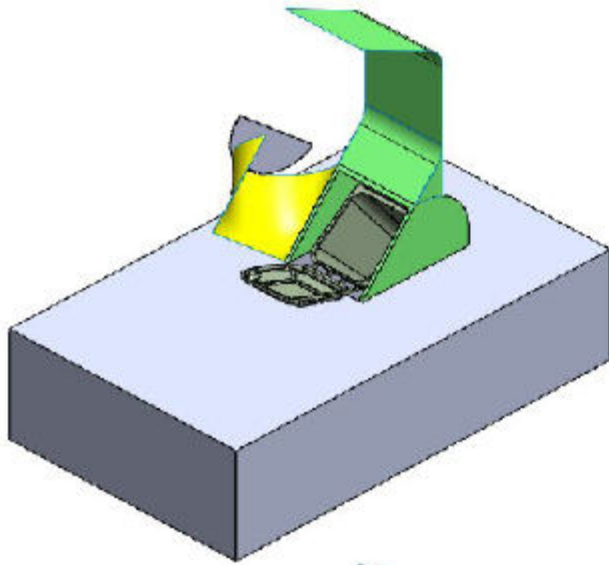

CONCEPT 2

SMALLER CAPACITY STORAGE

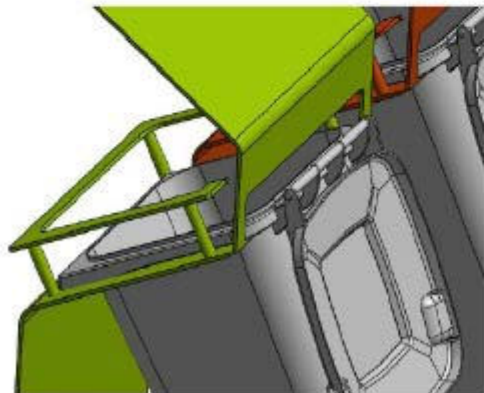
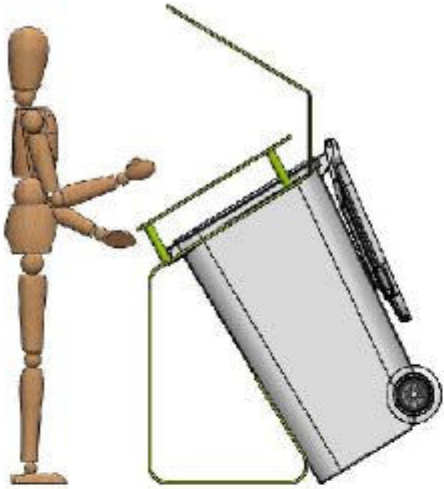

CONCEPT 2 FINAL

SMALLER CAPACITY STORAGE

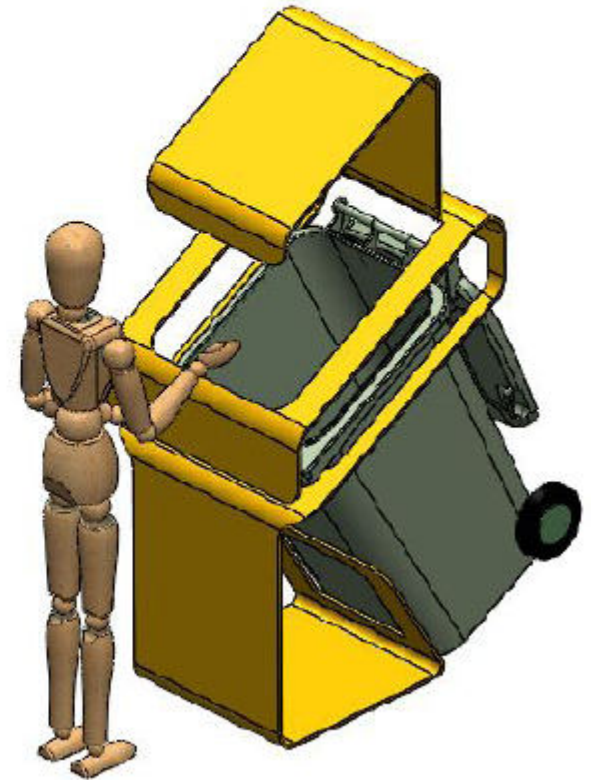
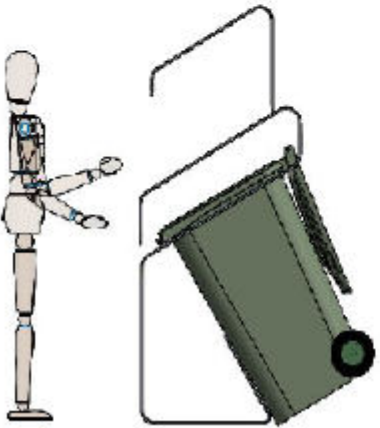
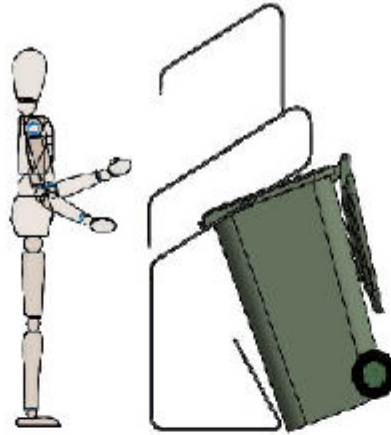
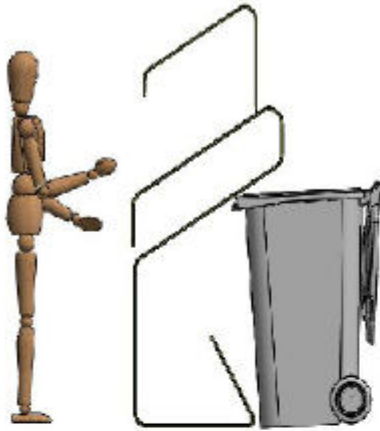

CONCEPT 3

ABOVE GROUND STORAGE

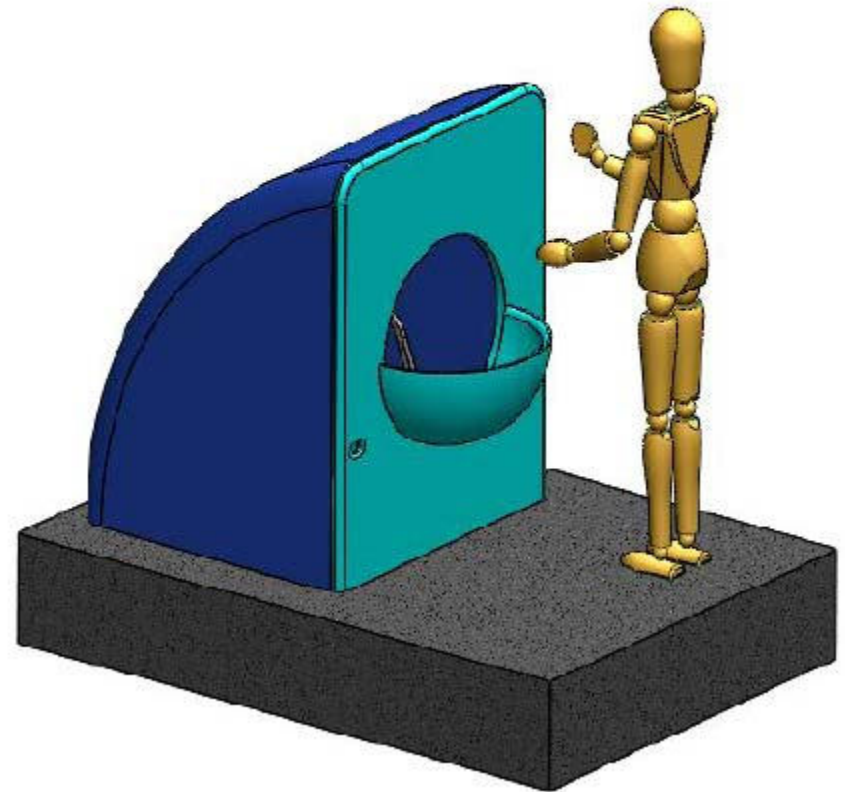
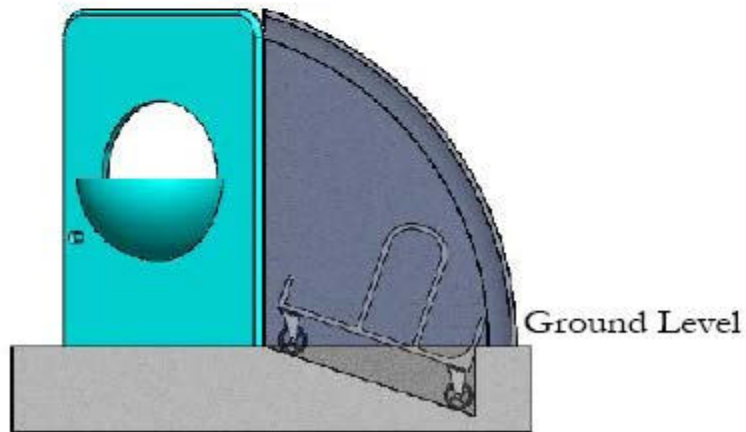
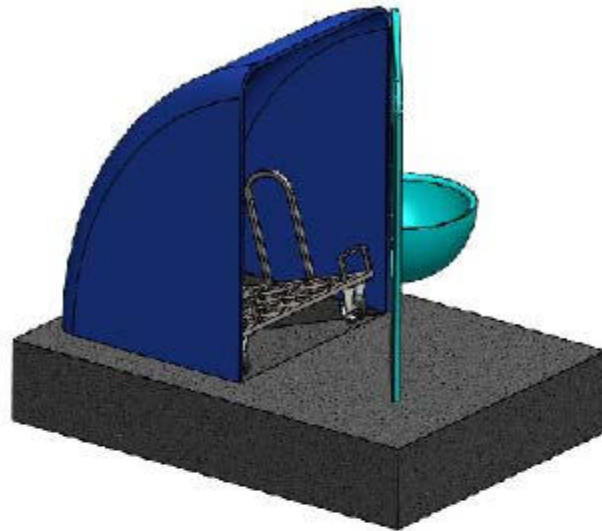

CONCEPT 3

ABOVE GROUND STORAGE

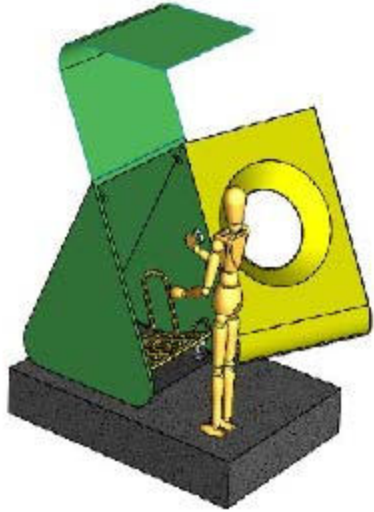

CONCEPT 3

ABOVE GROUND STORAGE

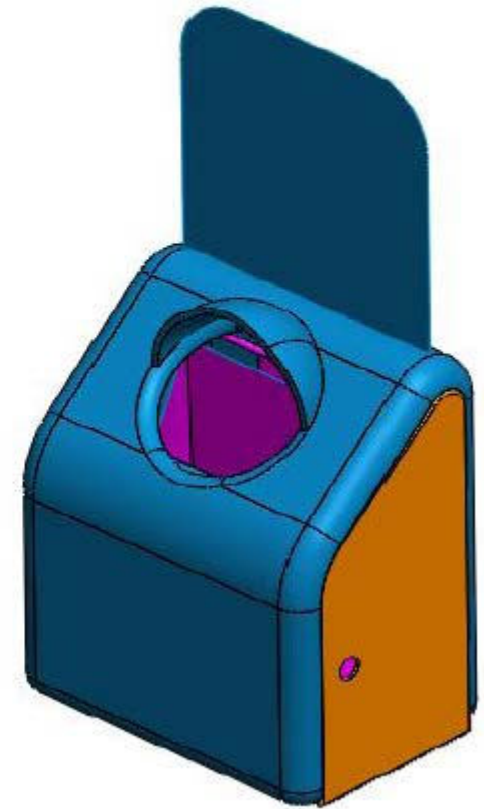
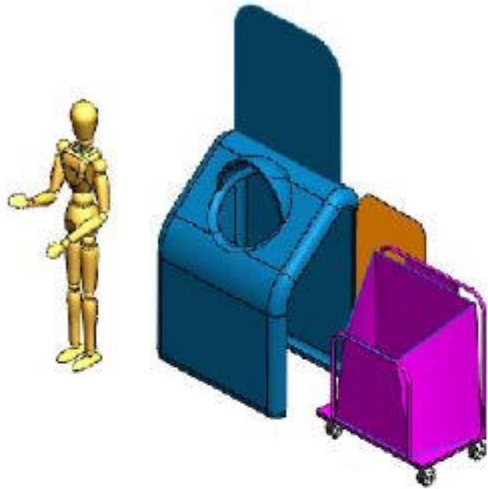

CONCEPT 3

ABOVE GROUND STORAGE

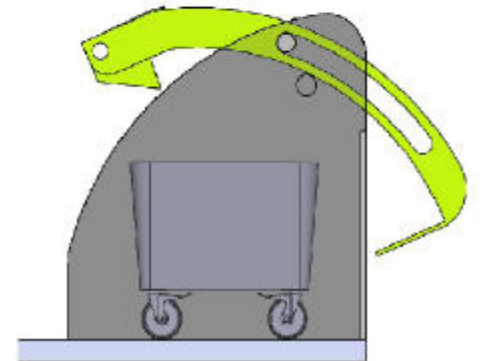
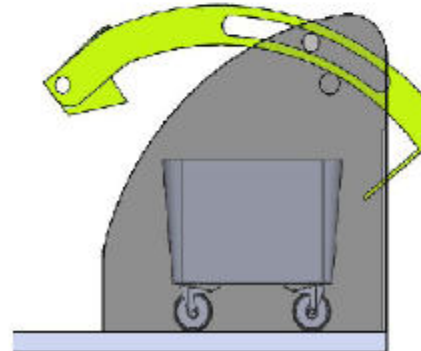
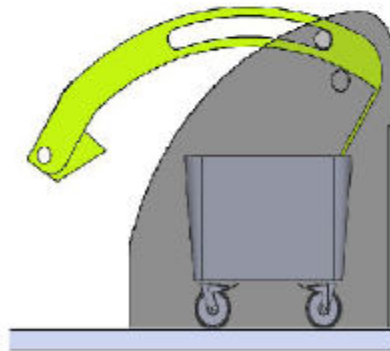
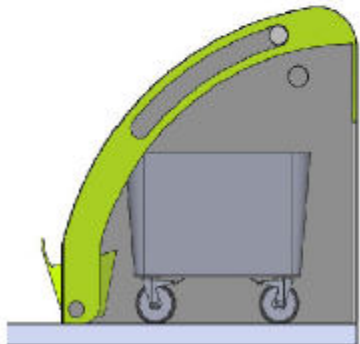
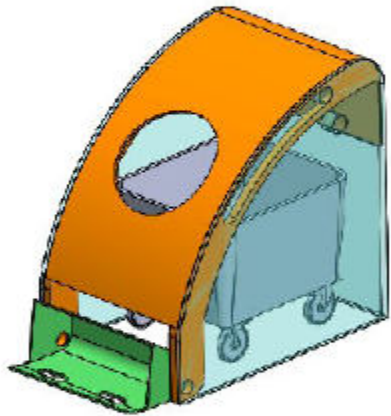
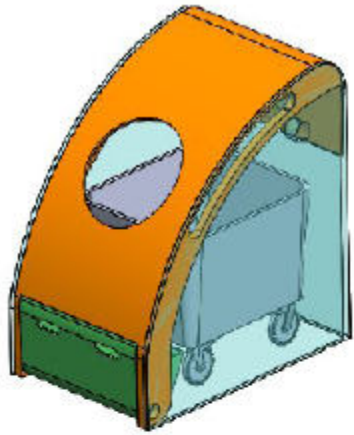

CONCEPT 3 FINAL

ABOVE GROUND STORAGE

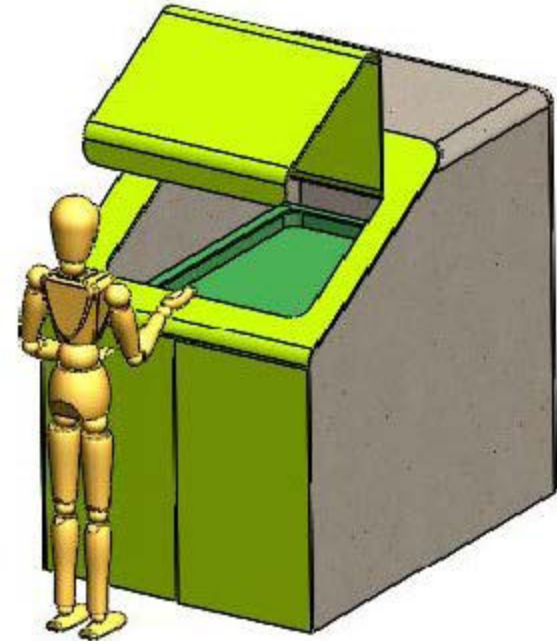
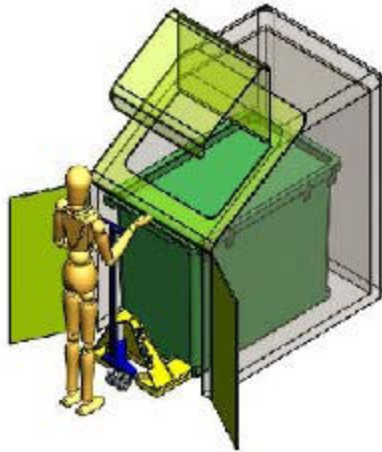
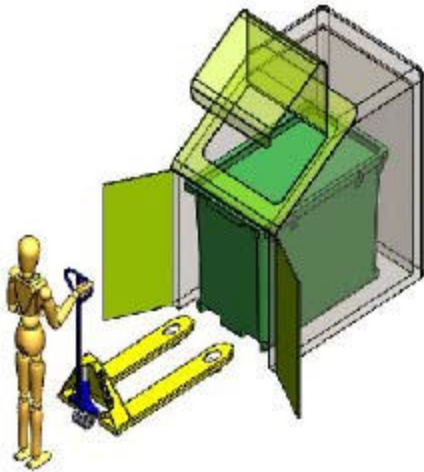

CONCEPT EVALUATION

CONCEPT EVALUATION



Hygiene (25%)	3	3	3
Segregation (25%)	4	3	3
Usability (30%)	2	5	3
Feasibility (20%)	3	5	4
	2.95	4	3.2

- **HYGIENE**

- Pest resistance
- User contact required?

- **SEGREGATION**

- Space for proper signage
- Multiple unit deployment

- **USABILITY**

- By all users, sought experienced feedback

- **FEASIBILITY**

FINAL CONCEPT

ABOVE GROUND STORAGE

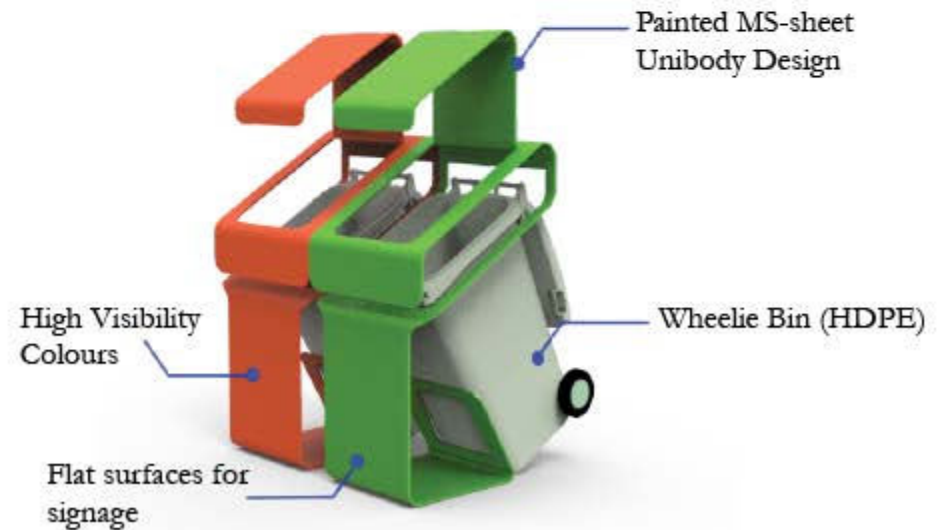
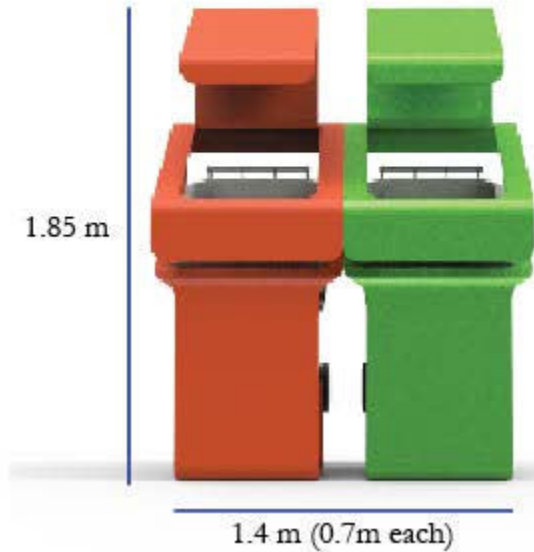

FINAL CONCEPT

SIGNAGE

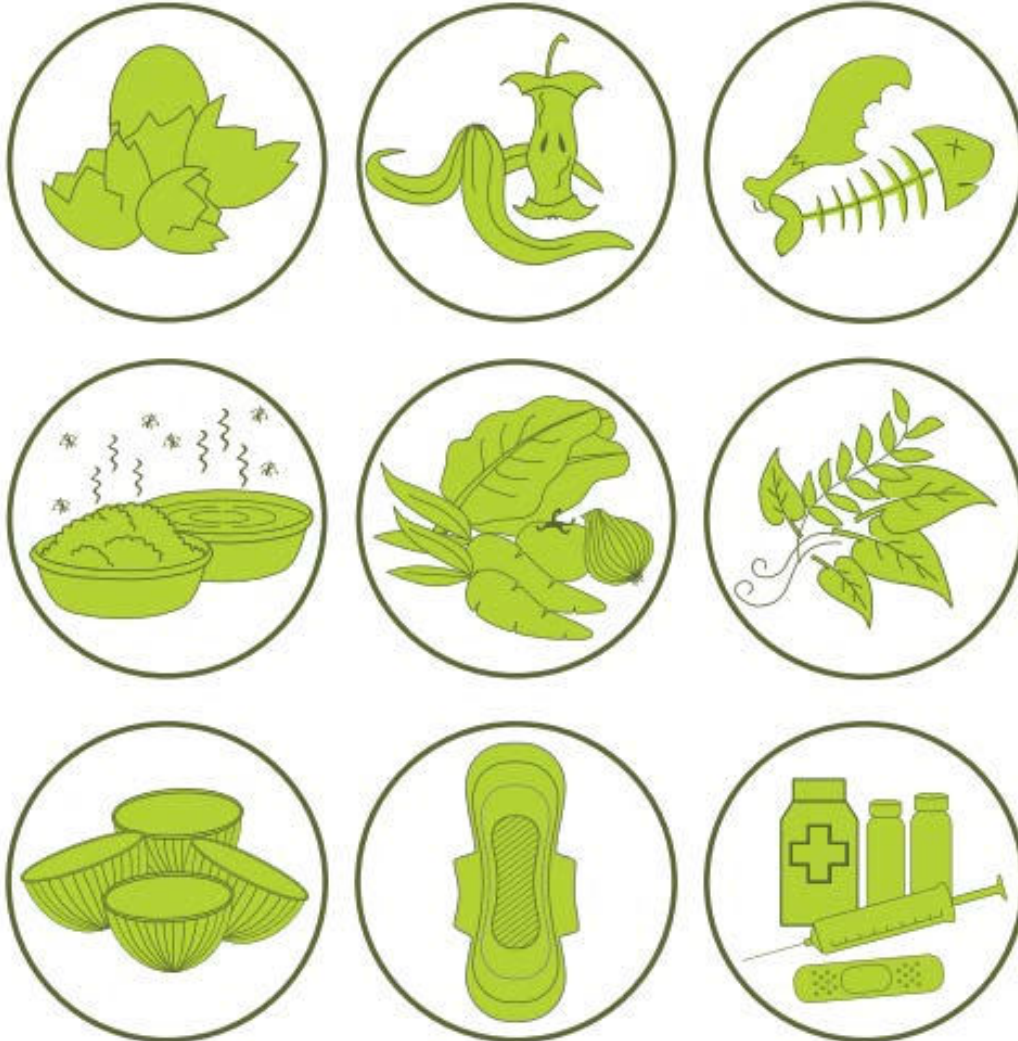

WET WASTE

गीला कचरा

FINAL CONCEPT

SIGNAGE

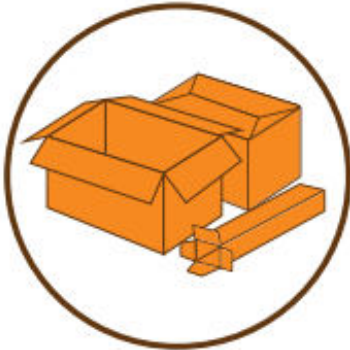
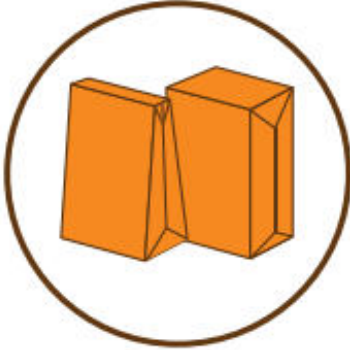

DRY WASTE

सूखा कचरा



R 178	C 35
G 210	M 0
B 53	Y 100
	K 0



R 246	C 0
G 139	M 55
B 31	Y 100
	K 0

FINAL CONCEPT

DEPLOYMENT



FINAL CONCEPT

PRODUCT DEPLOYMENT



FINAL CONCEPT

PRODUCT DEPLOYMENT

- STREET INTERSECTIONS
- BUS STOPS
- PUBLIC SPACES
- OUTSIDE RESTAURANTS / FOOD AREAS
- LARGER CAPACITY FOR MARKET AREAS

TEST RIG

PRODUCT DEVELOPMENT



FINAL RIG

PRODUCT DEVELOPMENT

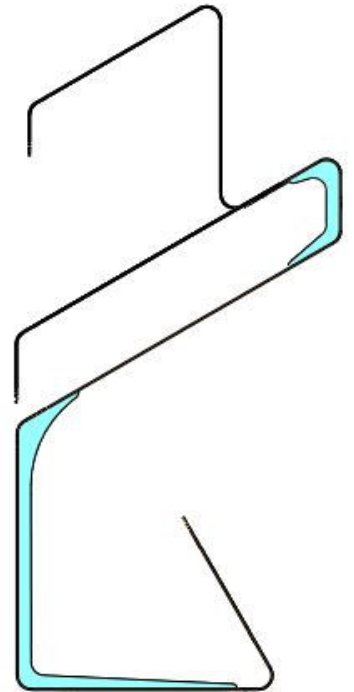
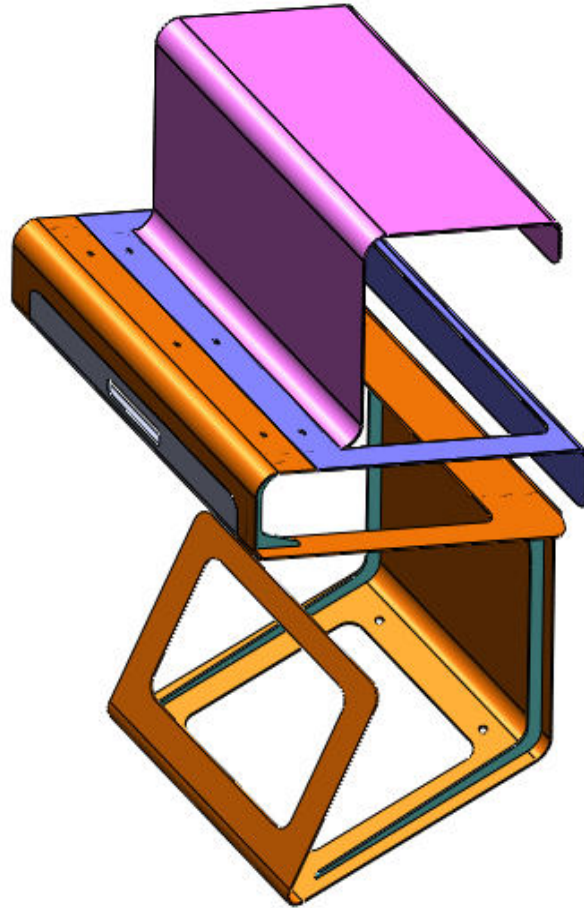
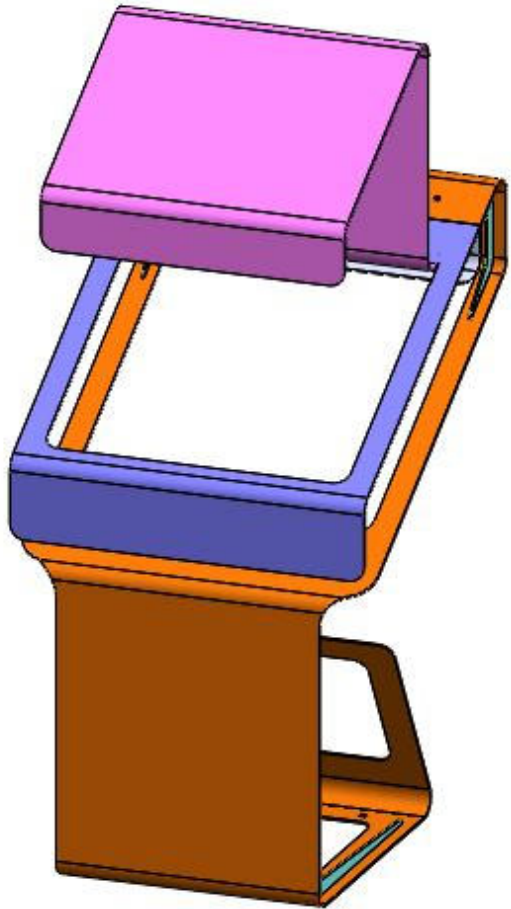

FINAL RIG

MANUFACTURING



FINAL RIG

MANUFACTURING



NEXT STEPS

ANALYSIS

1. DESIGN OPTIMIZATION

- Stronger, sturdier design
- Vandal Proofing

2. MANUFACTURING

- Lesser thickness sheet, explore detailing options such as folding bending, dimpling, etc.
- Variants of this design using pipe-chassis structures and sheet fascia
- Design for faster, more efficient manufacturing

3. VALIDATION THROUGH PILOT DEPLOYMENT

