



# Redesign of CPAP Device

Deepanwita Ghosh 126130009

Guide : Prof. Purba Joshi    Co-Guide : Prof G.G.Ray

# The Background- Global Neonatal Statistics

The **first minute** after birth is the most critical period for an infant and hospitals need to be prepared for exigencies like asphyxia, caused due to airway blockage.

## The "Two-Thirds" Rule :

- Almost two-thirds of infant deaths occur in the **first month** of life.
- Among those who die in the first month, about two-thirds die in the **first week** of life.
- Among those who die in the first week, two-thirds die in the **first 24 hours** of life.

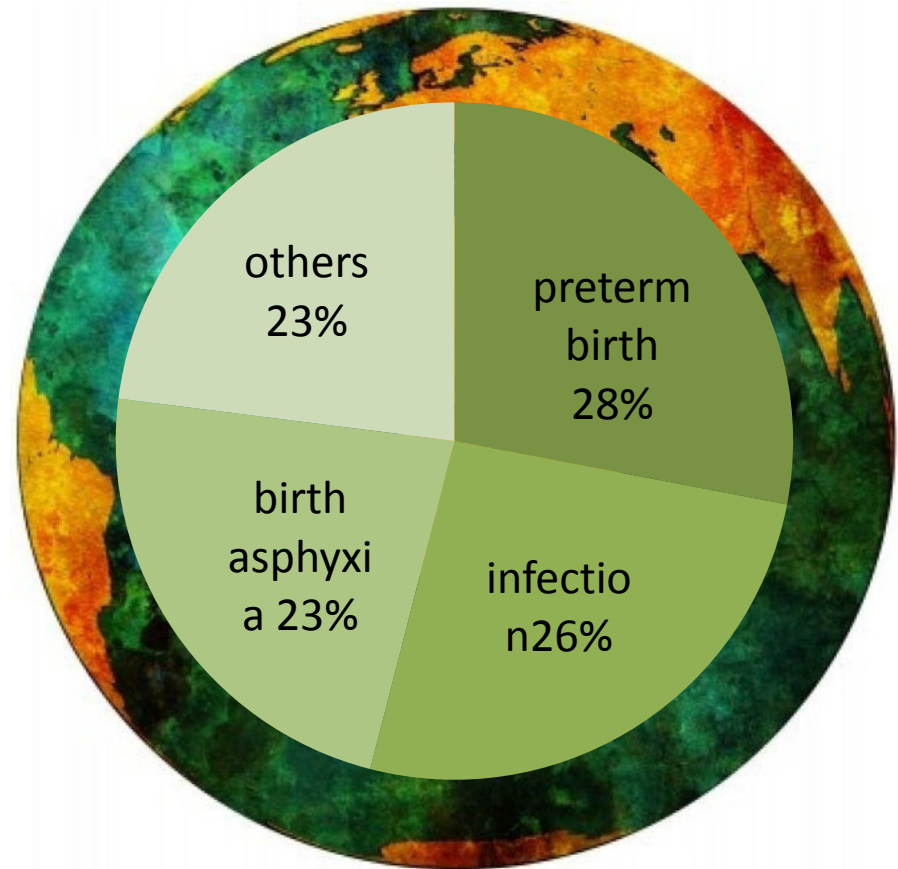

# A Look at Infant Mortality Statistics- India



India is one of the largest contributors with **309,000** newborn deaths in the **first 24 hours** and **876,000** in the **first month**.

This accounts for nearly **28% of the global deaths** among newborn children (Oestergaard et al., 2011)

**50%** of all deaths at 1-59 months are due to:  
**pneumonia , asphyxia and diarrheal diseases**

*And more than 50% of newborn deaths occur at home*

# Major Reasons

**5** factors that affect child survival :

- maternal factors
- environmental contamination factors
- nutrition availability factors
- injury factors
- personal illness control factors

*- W. Henry Mosley and Lincoln C. Chen, 'An analytical framework for the study of child survival in developing countries'*

Three main reasons why despite India's growth, neonatal mortality rates remain high are:

- socio-economic factors
- lack of infrastructure
- inadequate specialized staff for maternal and infant care for pre, during and post birth

*- 'Neonatal mortality in rural India: Does access to health infrastructure play a role?' by Anu Rammohan, Kazi Iqbal and Niyi Awofeso*

# Research Findings

In a research paper written by Anu Rammohan, Kazi Iqbal and Niyi Awofeso, data from the unique nationally representative survey of India 2008 *District Level Household Survey (DLHS-3)* was used to analyze '***the links between neonatal mortality at the household level and household's access to health facilities***' and their findings state the importance of '*having well-functioning obstetric and neonatal services of District Hospital closer to the rural households*'.

The results show that if the '*services of District Hospitals are **brought 10 km closer to the village, it can save one more child out of 1000 births in India***'. Another important finding was to have emergency obstetric care at the District Hospital –which is also found to significantly reduce neonatal deaths

# Other Challenges

- Least investment, research and innovation.
- Not appropriate to the local conditions where they are implemented.
- Not affordable - *from both design services and cost point of view*



# The Existing Conditions - an example



Study of 44 public hospital facilities for Infant and Maternal Care Infrastructure :



Only 19 had qualified obstetrician/s  
Only 13 had qualified anaesthetist/s  
while 77% do not have either/ both of these specialists  
*(Chartuvedi and Bandime, 2010).*

India has a **chronic shortage** of the core staff, with less than 23 doctors, nurses and midwives per 10,000 populations.



# The Oxygen Delivery System-CPAP System

Continuous Positive Airway Pressure ( CPAP ), when administered to neonates, re-expands collapsed alveoli, splints the airway, reduces work of breathing and improves the pattern and regularity of respiration

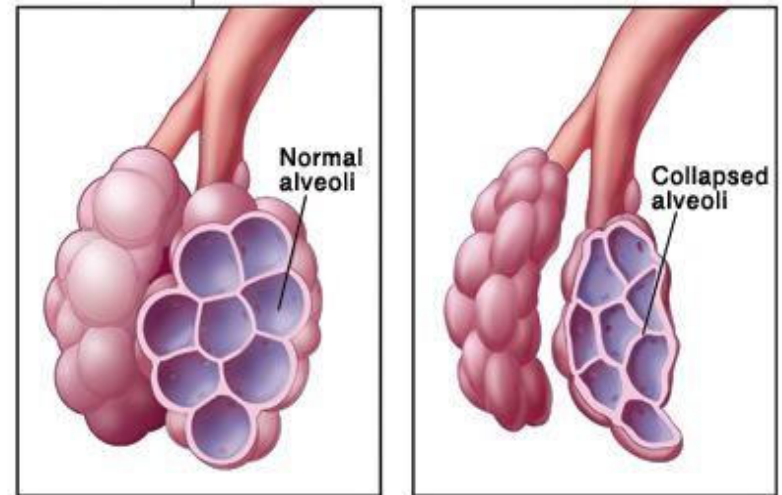
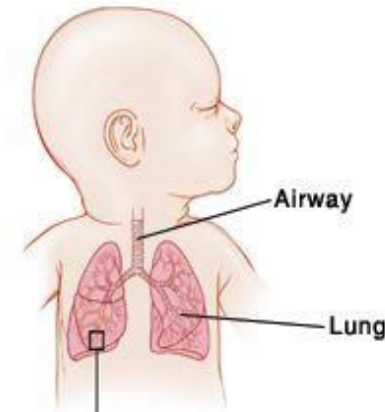
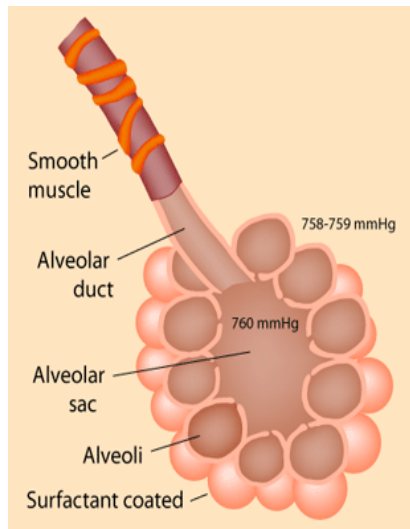

Air travels through the airways (tubes in the lungs) to the alveoli (air sacs). Normally, alveoli stay open after each breath. RDS occurs when alveoli collapse after each breathe. This means the baby has to work harder to breathe.

# Condition for CPAP

A baby is completely formed by its 13th week of gestation and spends the forthcoming 27 weeks developing and evolving inside the womb. For a premature baby, the main difficulty is that they are **born before their body is developed** enough to live outside the sheltered environment of their mother's womb. During such conditions, generally, the most fatal problems develop due to **immaturity of the lungs**.

While in the uterus, the lungs have no function to perform. They are filled with fluids and are deflated. The developing baby gets its supply of oxygen from its mother. Usually during birth, with the baby's first breath, **the fluid is expelled and air rushes into the lungs and inflate them**- getting them to work. Due to prematurity, the lungs cannot expire and inspire air naturally. The oxygen that they will inspire to their lungs with great difficulty is not sufficient for their needs.

# Condition of the Lungs in Infants

Without CPAP



Exhale



Inhale

Exhale



Inhale

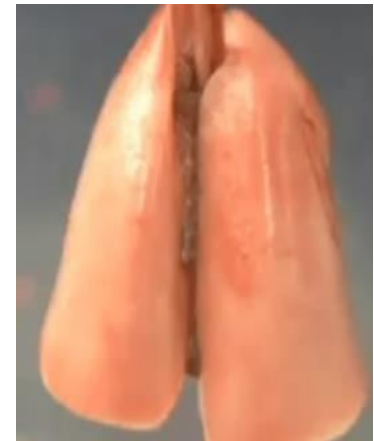
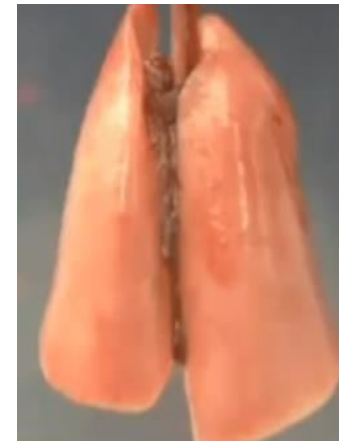
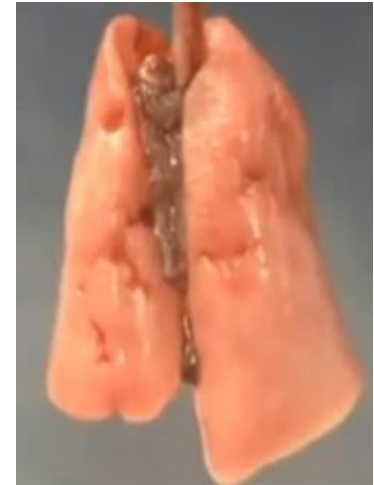

With CPAP

# When is CPAP Used?

- See-saw effect in chest and stomach
- Nasal flaring
- Sternal in drawing
- Rib-retractions
- Grunting
- Respiratory Distress Syndrome- incomplete lung development due to insufficient surfactant
- Pneumonia
- Asphyxia



# Components of the System

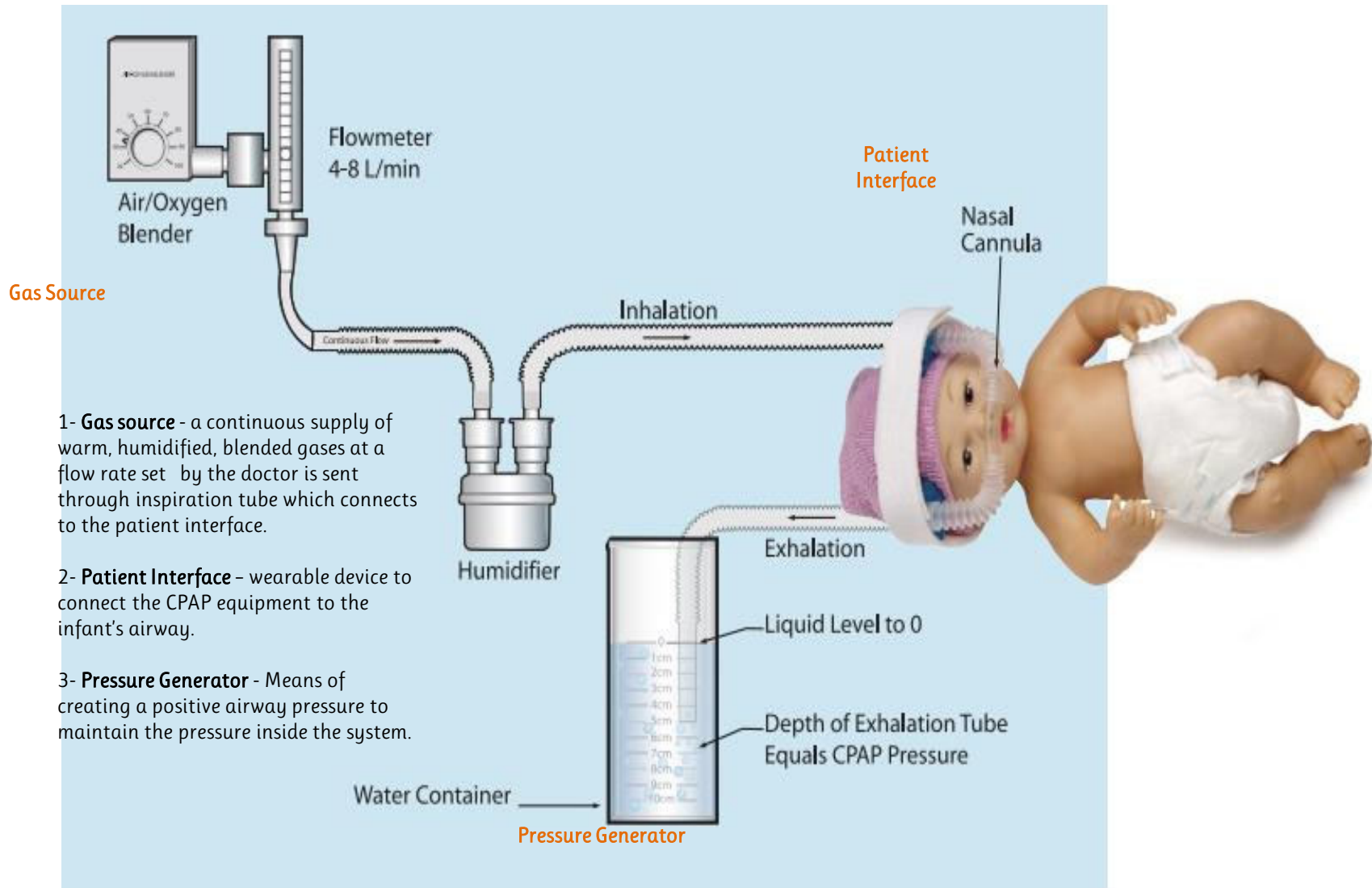

# Necessities with CPAP

CPAP must be used carefully whenever administered. If CPAP is provided, **pulse oximetry** should be used to confirm appropriate concentration of oxygen. Pulse oximetry is used as a non-invasive tool to observe oxygen saturation, which should be **maintained at 85-93%**

Once CPAP is administered, the baby should be reassessed to determine whether the initial problems have resolved or whether CPAP should be continued as part of post-resuscitation care.



# Different Interfaces for the patient

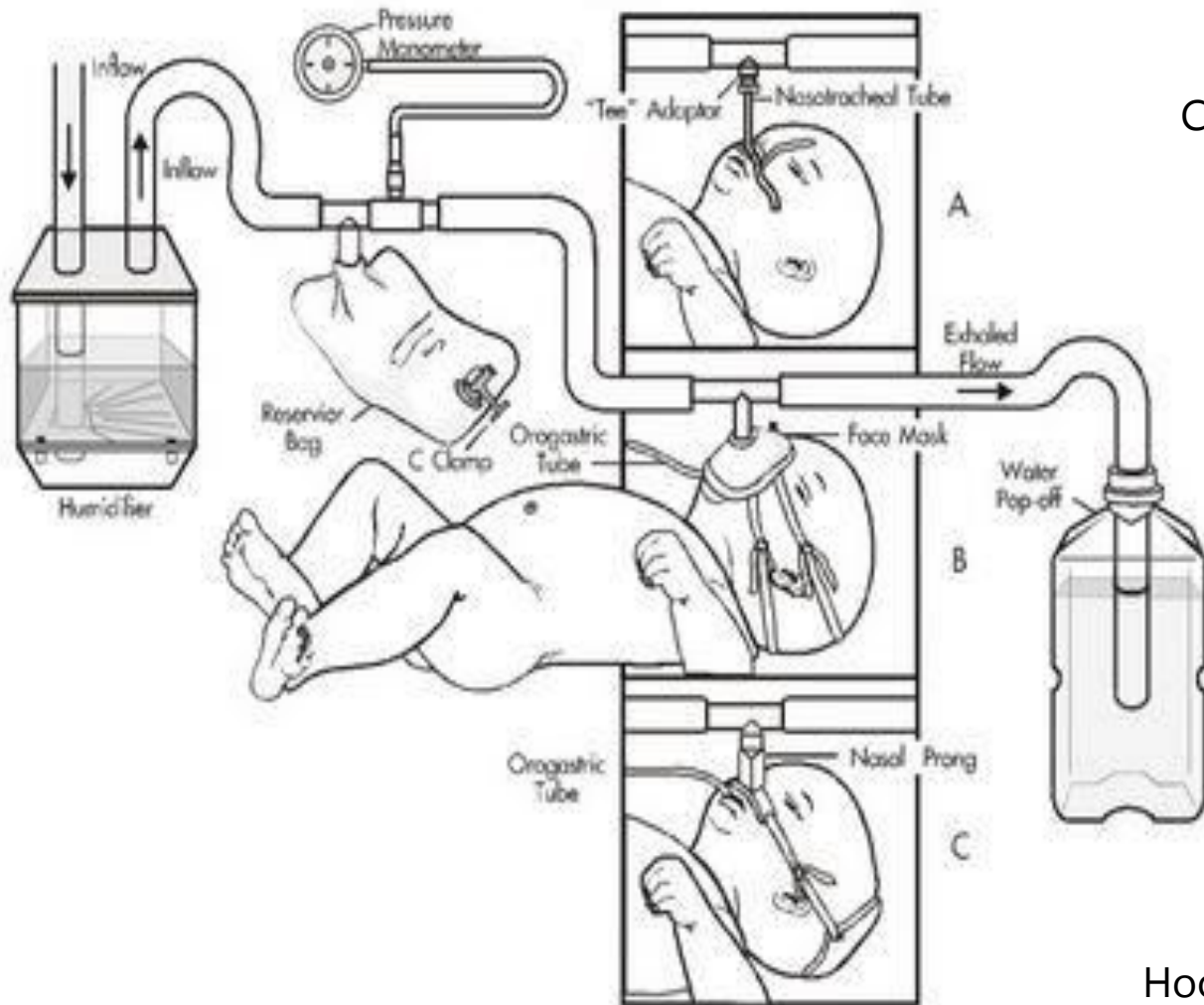

Nasal Cannula



Mask



Hood



# Insights from Literature Study

Respiratory related distresses are the major cause of deaths within the first minute of the infant's life

Huge need to improve access to innovative solutions offering clinical performance, ease of use and affordability that if the '*services of District Hospitals are **brought 10 km closer to the village, it can save one more child out of 1000 births in India***'.

**Monitoring System is essential for determining the effectiveness of the CPAP device**

# Data Collection from Field study

Hinduja Hospital ( A Leading Multi-Speciality Healthcare Hospital )

Mahim West, cadell road, Veer Savarkar Marg, Mumbai, 400016

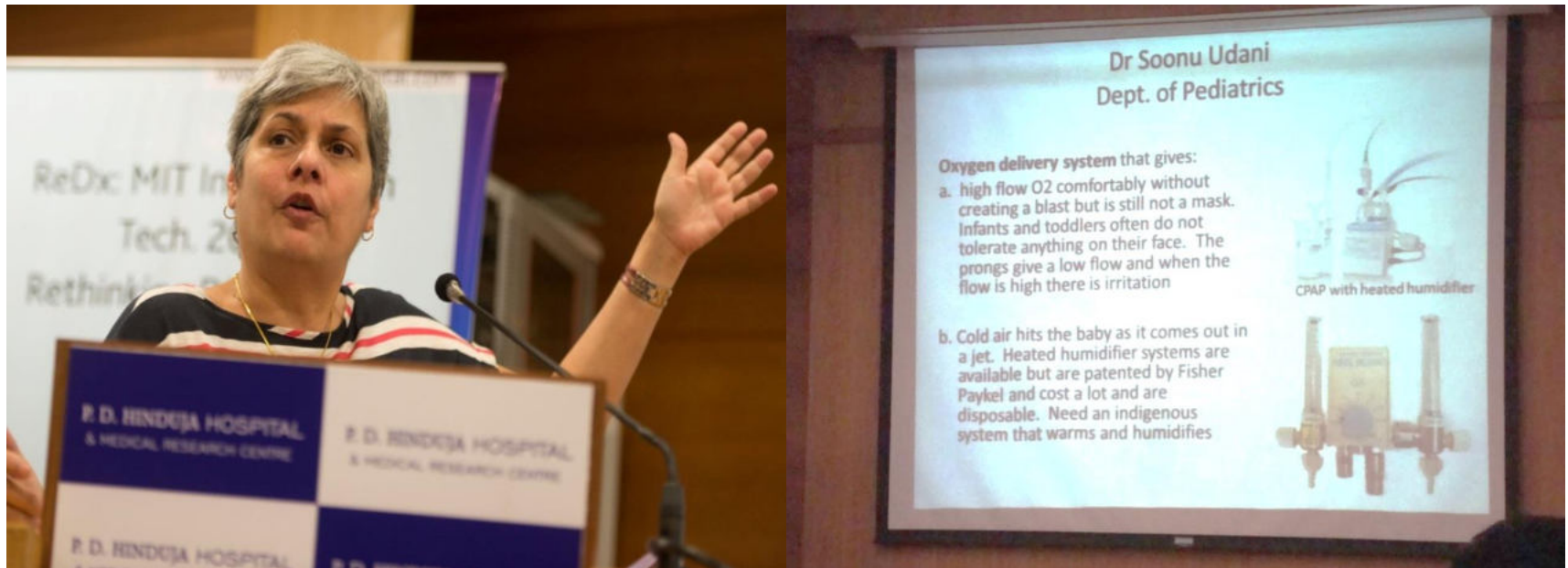

# Data Collection from Field study

IIT-Bombay Campus Hospital (Government Run)

Powai, Mumbai, Maharashtra 400076



# Data Collection from Field study



## Insights:

The IIT Hospital had a very basic set-up of a warmer which was not in use as the maternity ward was dysfunctional. But they showed us the way the hood would be used had a baby required oxygen support.

- The unit looked very difficult to handle
- There were two knobs on the side which were used to fix the slider position to prevent oxygen from leaking out and it kept slipping down.
- There was no provision for the oxygen tube attachment which is the inspiration tube and it had to be fixed using a masking tape.
- Major losses in oxygen flow happened through the slide opening

Fig 12 - shows the setup of the warmer and the hood which is now not in use

Fig 13 - shows the Interface of the warmer

Fig 14 - two hood sizes being displayed- one for smaller infants and the other for a larger one

Fig 15 - nurse demonstrating the use of the hood

Fig 16 - the hood with all its features

# Data Collection from Field study

Discussion with Doctor Abhishek at Lokmanya Tilak Municipal Hospital



Insights:

- Doctor mentioned that from all the methods of oxygen administration, clinically it is proven that the nasal cannula is the most effective interface
- The attachment of the interfaces are quite problematic
- The infants are subjected to a lot of rough handling in the process of attaching the equipment firmly.

Fig 26,27 - the mask used for a smaller sized neonate and a larger sized neonate- the aluminum clip at the top fixes it on the nose bridge  
Fig 28- Dr. Abhishek showing the problems associated with the hood  
Fig 29 - Jugad method of connection of the tubings  
Fig30 - the nasal cannula attachment

# Data Collection from Field study

## Visit to Lokmanya Tilak Municipal Hospital



Fig 17 - LTM Hospital, Sion

Fig 18 - the CPAP set-up in the NICU

Fig 19 - the humidifier interface showing an error in reading

Fig 20 - space crunch-two infants share the same bed, one being given oxygen support through hood

### Insights:

The LTM Hospital had a very different crowd of people coming for treatment it compared to the Hinduja Hospital which is a hospital with high end facilities. Since this is a government hospital, the facilities are not up to date and had a lot of maintenance issues as mentioned by the doctors we interacted with.

- The cpap unit had many handling issues
- The stand was on wheels and locking it for stability was an issue
- There were a lot of tubings coming into and away from the system which gave a disordered look
- The humidifier display gave erroneous output and yet it was being used
- The connections of the tubings were not tight enough and would come off easily

# Data Collection from Field study

## Visit to Lokmanya Tilak Municipal Hospital

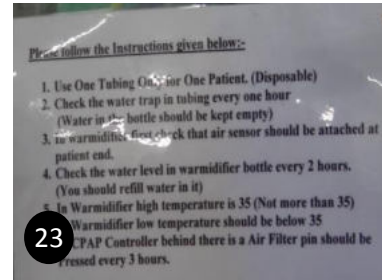

Fig 21 - shows how the interface is attached to the infant using rubberband, safety-pins and masking tape.

Fig 22 - position to see the reading on the humidifier, check the bubbling of the air in the water container.

Fig 23 - the list of do's n don't's

Fig 24 - blender unit's interface

Fig 25 - the chart for air and oxygen blending ratio.



Insights:

- The tiny infant was hooked on to the device using a lot of tapes and pins which showed signs of injury on the skin and nasal trauma
- The blender unit had knobs for rotating it to the flow required and was placed quite away from the water column - confusing alignment
- The chart for the air-oxygen ratio was placed on the side creating visibility issues.
- The entire set-up needed accessibility from 3 sides to work on it, fix tubings and connect it to the power source.
- The stem of the bubble tube is inserted using hand and most of the time it remains at a slant.

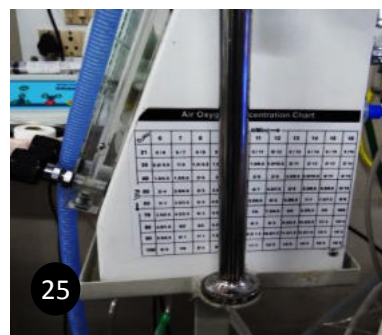

# Data Collection from Field study

Visit to Lokmanya Tilak Municipal Hospital



# Study Activity Analysis- Nasal Cannula



# Problems faced- Nasal Cannula

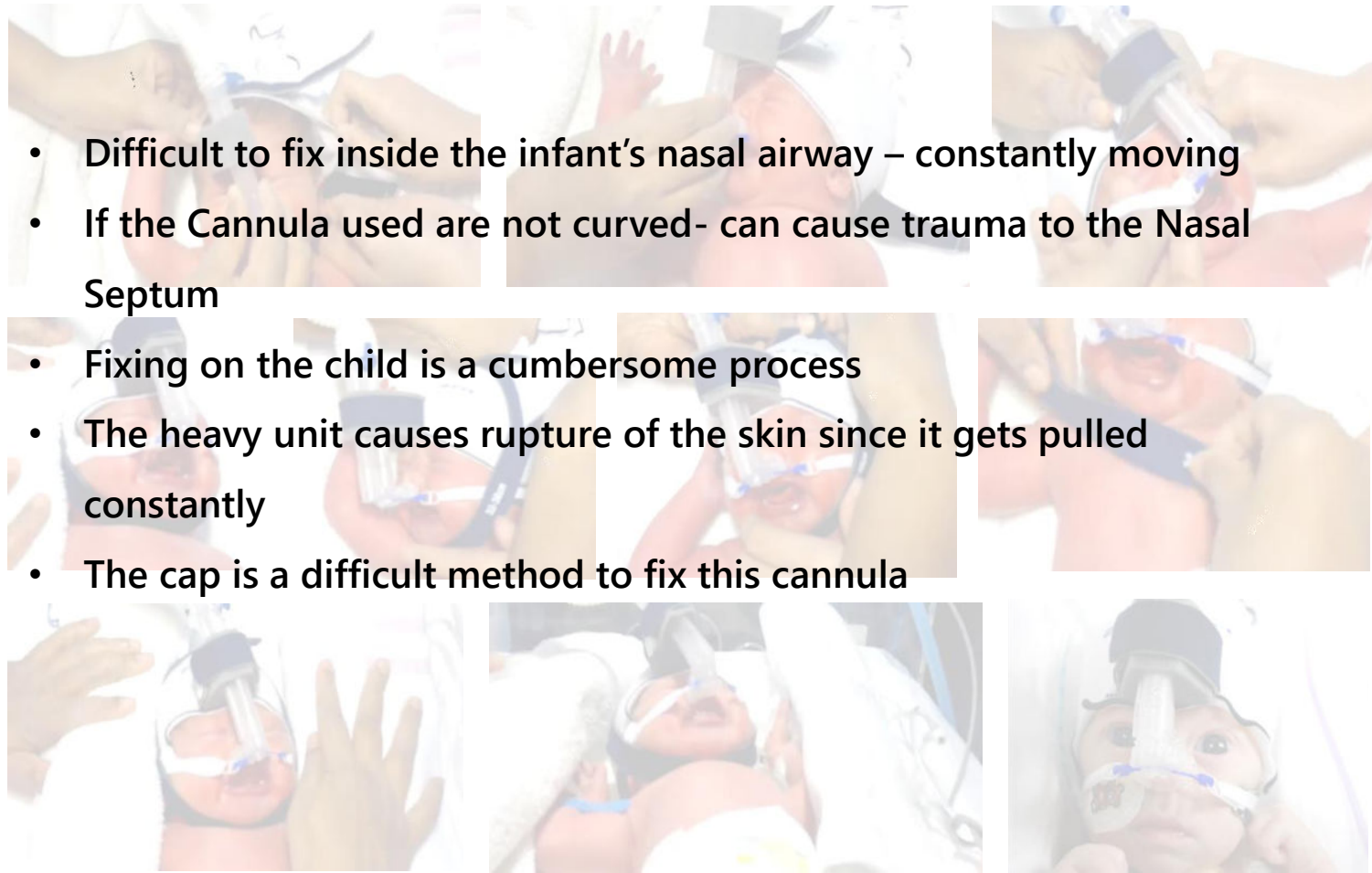

- Difficult to fix inside the infant's nasal airway – constantly moving
- If the Cannula used are not curved- can cause trauma to the Nasal Septum
- Fixing on the child is a cumbersome process
- The heavy unit causes rupture of the skin since it gets pulled constantly
- The cap is a difficult method to fix this cannula

# Patient Interface- Mask



- Available only in 2 sizes
- Fixing is a problem
- Straps have to be adjusted every time
- Provision for feeding not available

# Patient Interface- Hood



- Fixing the tubing is a problem- use of tapes mostly
- The adjustable opening flap is difficult to handle
- A lot of leakage happens in this device

# Current Equipment Available in Market



42



43



44



Fig 41,42,43,46 are the standard vertical CPAP devices available in the market.  
Fig 44- the components that get attached to form the unit.  
Fig 45- the horizontal cpap unit made by RICE university  
Fig 46 - set up by fisher & paykel and the interface attachments that come with it.

Ref for images taken from  
[www.alibaba.com](http://www.alibaba.com),  
veronicakatherine.b  
logspot

- The products are mostly in separate parts and they need to be assembled to make a functional unit.
- The unit as such has a less 'equipment like' feel.
- The network of tubings are distracting

# Parent's opinion – As Observers



"just seeing the change of machines from Vent to a C-PAP was a major milestone for my daughter."

"It was heart wrenching when his condition deteriorated and all of the **equipment was scary**, especially on a baby so small and young."

"It broke my heart to see him like that, it was very scary. He had been breathing without any machinery for almost 24 hours after his birth but he was getting tired, and the nurses were afraid he would give up. It is very overwhelming having a pre-mature baby, it's even more **overwhelming to see them all hooked up to everything**".

# Overall Insights & Directions

- Absence of Monitoring unit
- Comes with a lot of parts that need to be assembled/tested and then administered to the infant (total of 10 mins )
- Constant monitoring of vital signs as a feedback for the proper working of the system
- The patient Interface can be made more comfortable
- Usability issues with the system can be solved
- Consideration for a CPAP device which is suitable during transport environment as well as in ICU
- Equipment looks scary to parents with all the over hanging wires

# Defining Project Brief

To redesign the current CPAP system used for delivering oxygen to the infants. The focus would be to make it ***compact and portable , easy to use(intuitive) and maintenance free.***

## Primary Users

The primary users of the device are the doctors, nurse and specialized staff majorly, who have the required knowledge of the amount of medication and oxygen delivery etc.

## Secondary Users

The secondary users would be the infants who are being administered CPAP through this device. The Pre-term infants mostly and infants with respiratory complications. Also certain respiratory infections may occur in infants until 8 months which require cpap administration even after they have crossed the 25 week viability period.

## Need

From the inferences listed previously the need is to make the system more robust by solving the issues by design methodology/ process.

## Constraints

It must be noted that this project does not aim to make modifications in the existing internal medical technology in the equipment in any which way. The goal is to work out the solution considering there are no flaws in the internal technology. If any new concept possibility is suggested, then it would be done considering that it is an industrial standard and the technology has been used/applied/tested previously.

# Initial Ideations

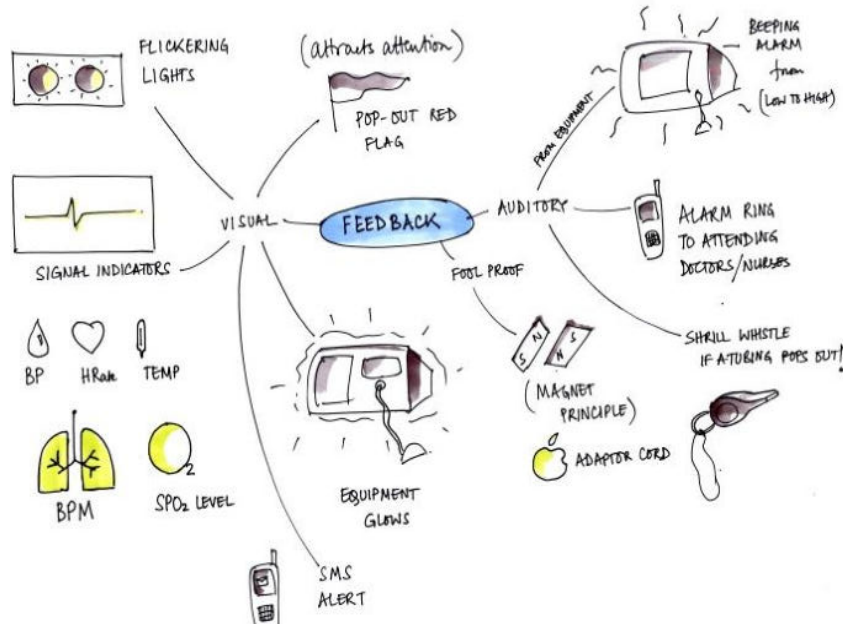

47 Mind Map of areas to look into for feedback which was lacking in the existing unit

## IF TUBES!

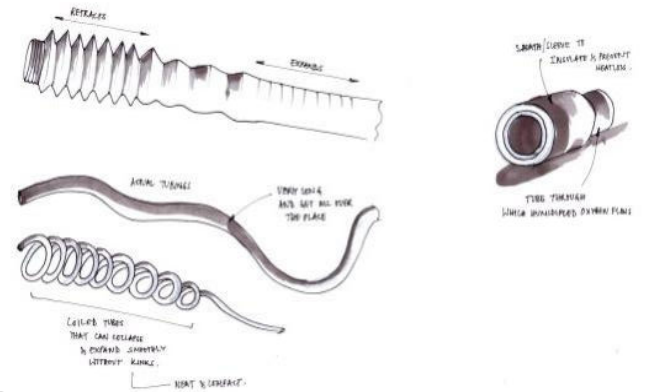

48 Tubing for inspiration and expiration

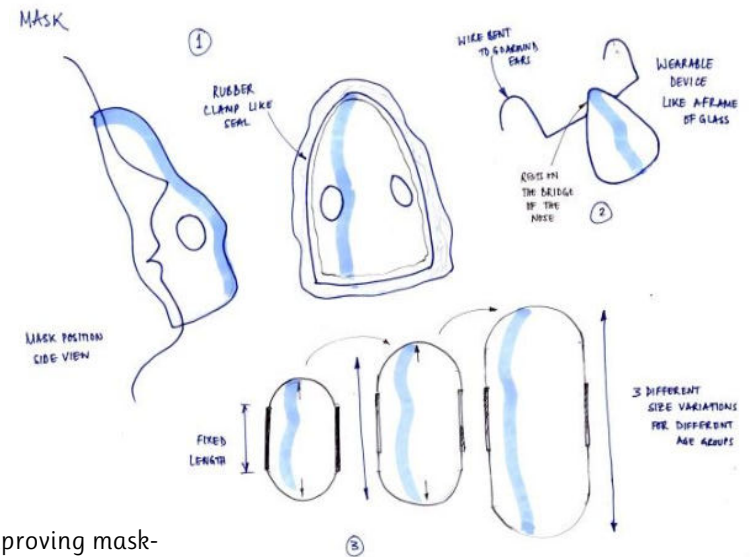

49 Improving mask-ideations

Ideations based on Separate subsystem - Bed/ warmer for in transit situations

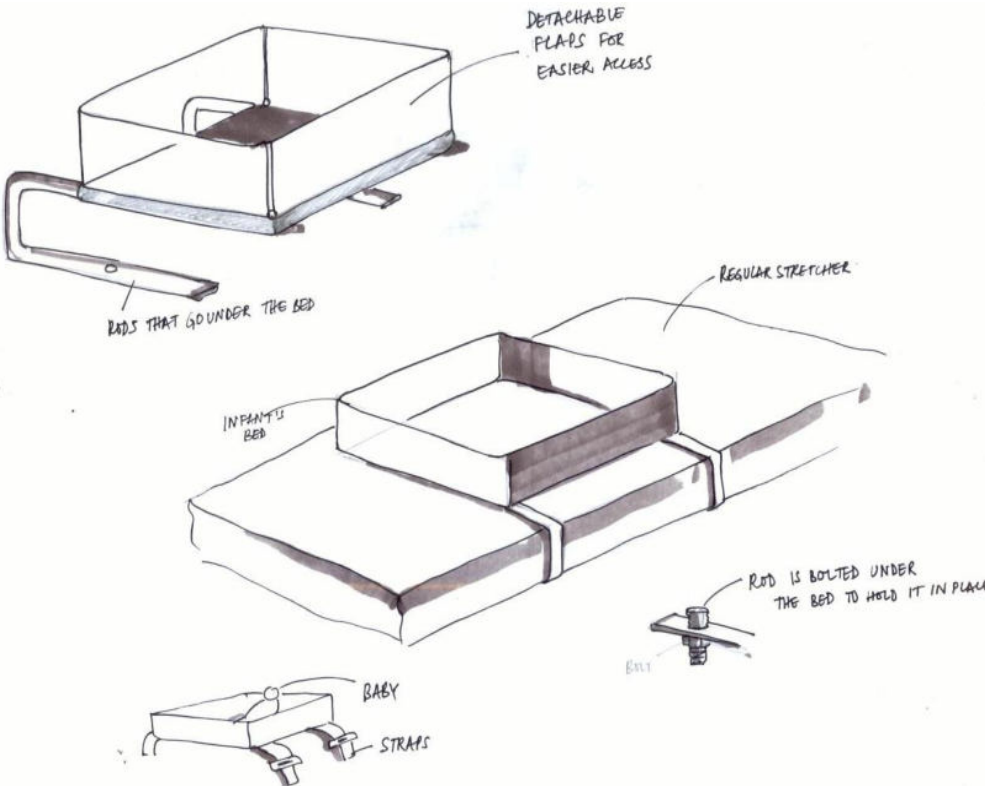

BED/WARMER INCUSIVE

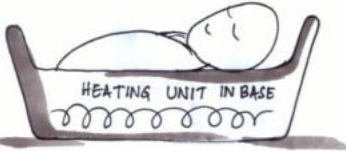

Picture shows the possibility of fixing a small bed unit on the regular stretcher in which the baby can be placed and the warming ideations are shown on the right side

## Ideations based on Separate subsystem - Connections

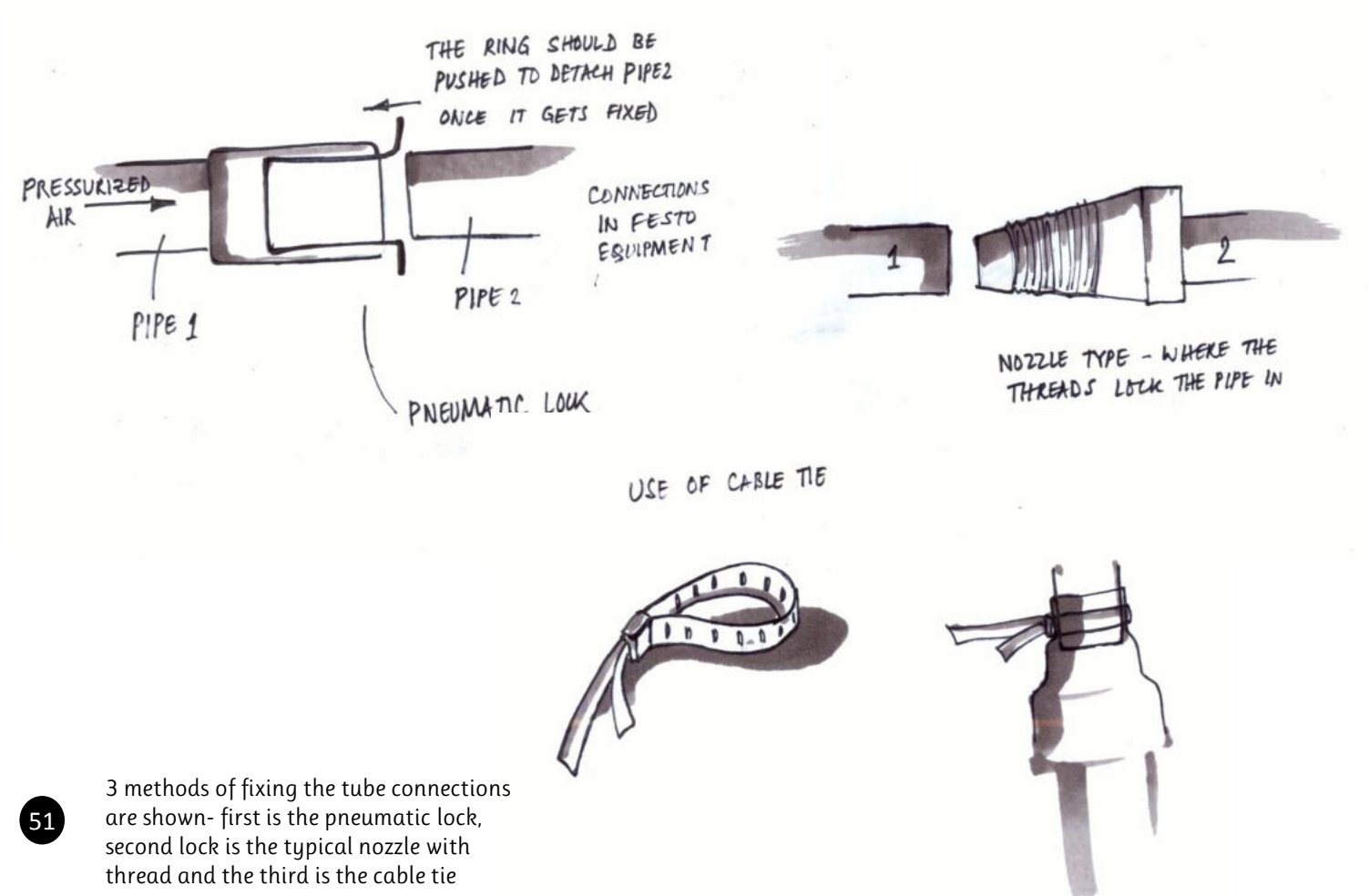

51

3 methods of fixing the tube connections are shown- first is the pneumatic lock, second lock is the typical nozzle with thread and the third is the cable tie

# Ideations based on Separate subsystem - Bubble Unit

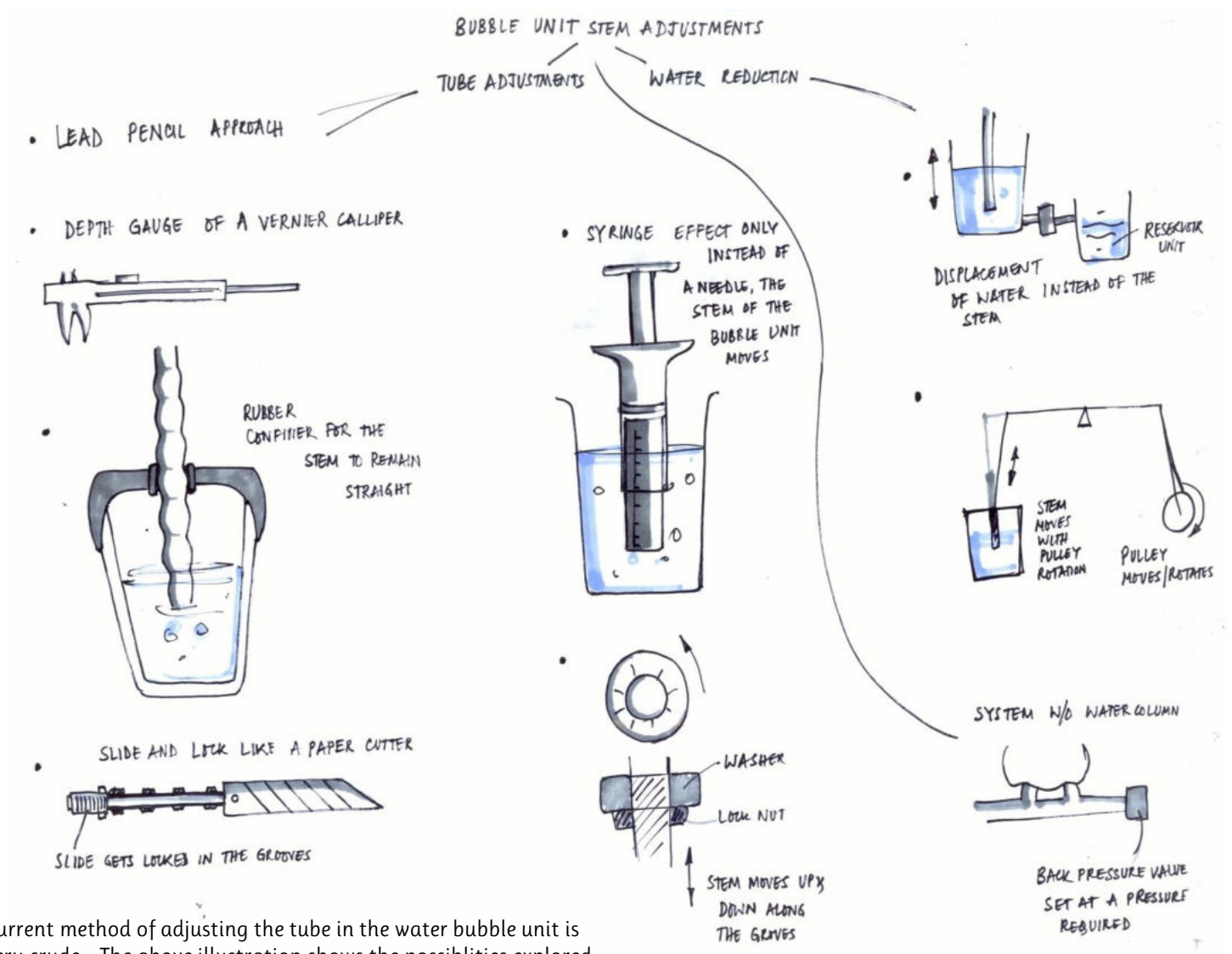

52 Current method of adjusting the tube in the water bubble unit is very crude. The above illustration shows the possibilities explored.

Ideations based on Separate subsystem - water unit for humidifier

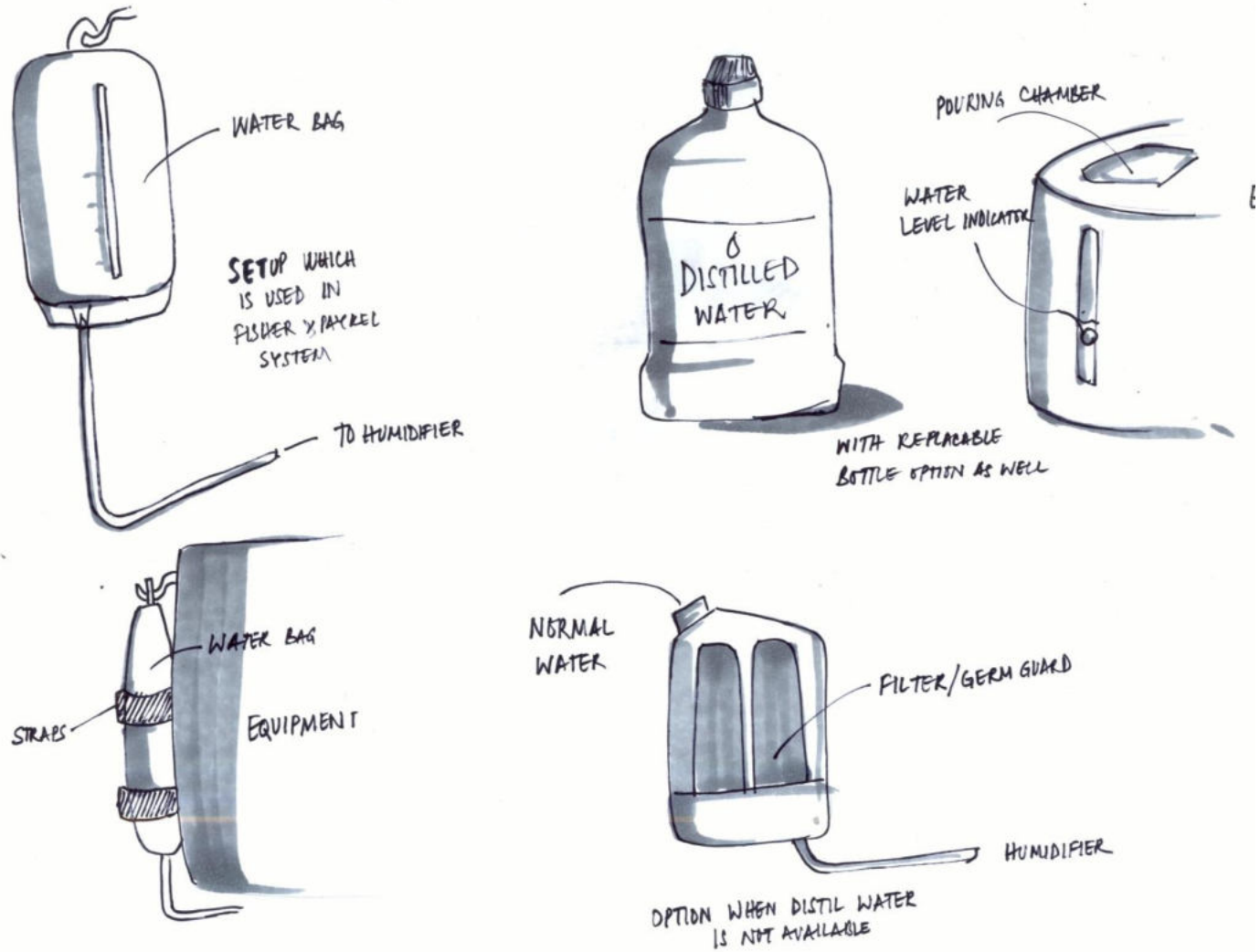

Ideations based on Separate subsystem – patient interface

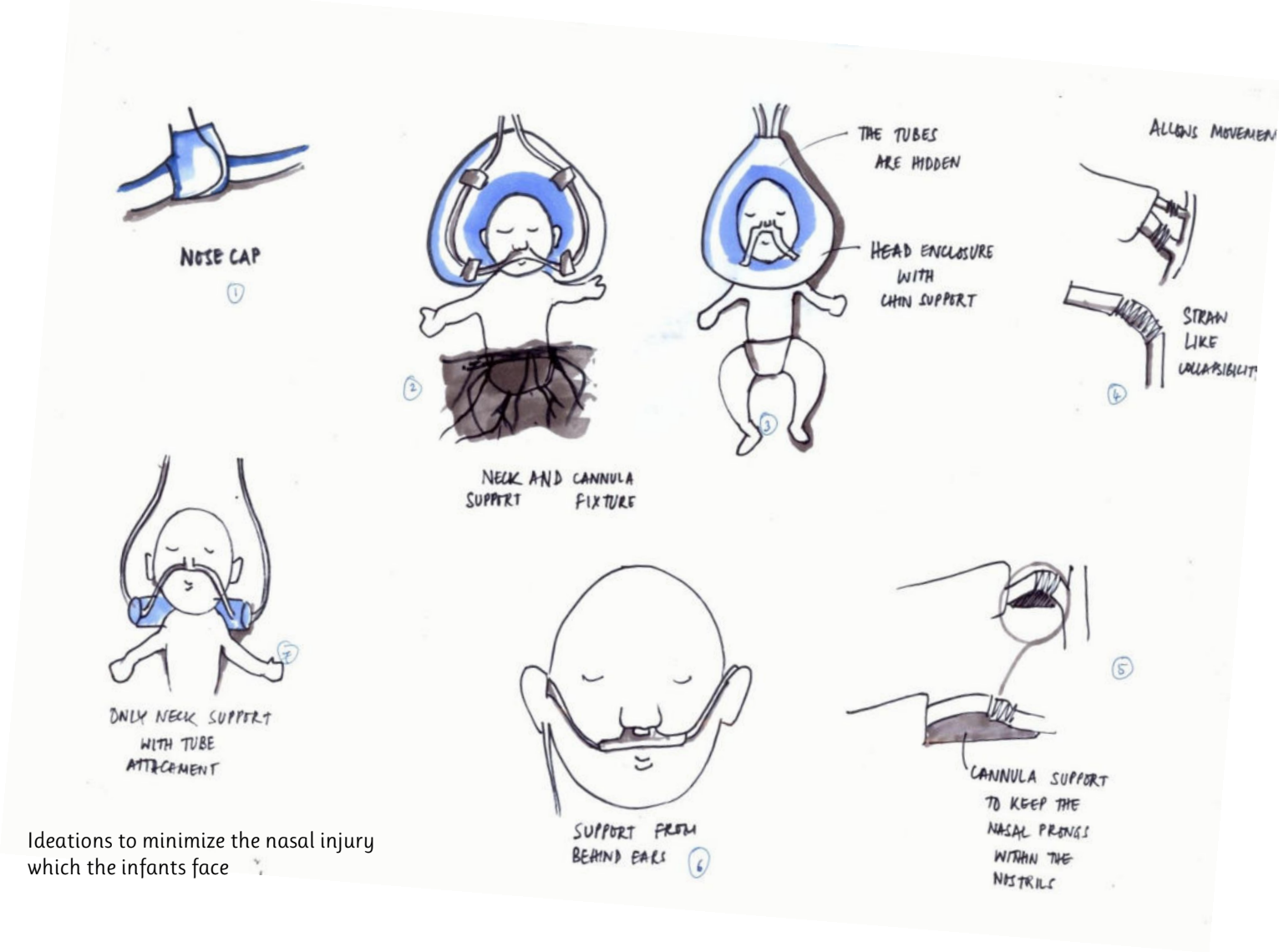

Ideations to minimize the nasal injury which the infants face

Ideations based on Separate subsystem – storage unit

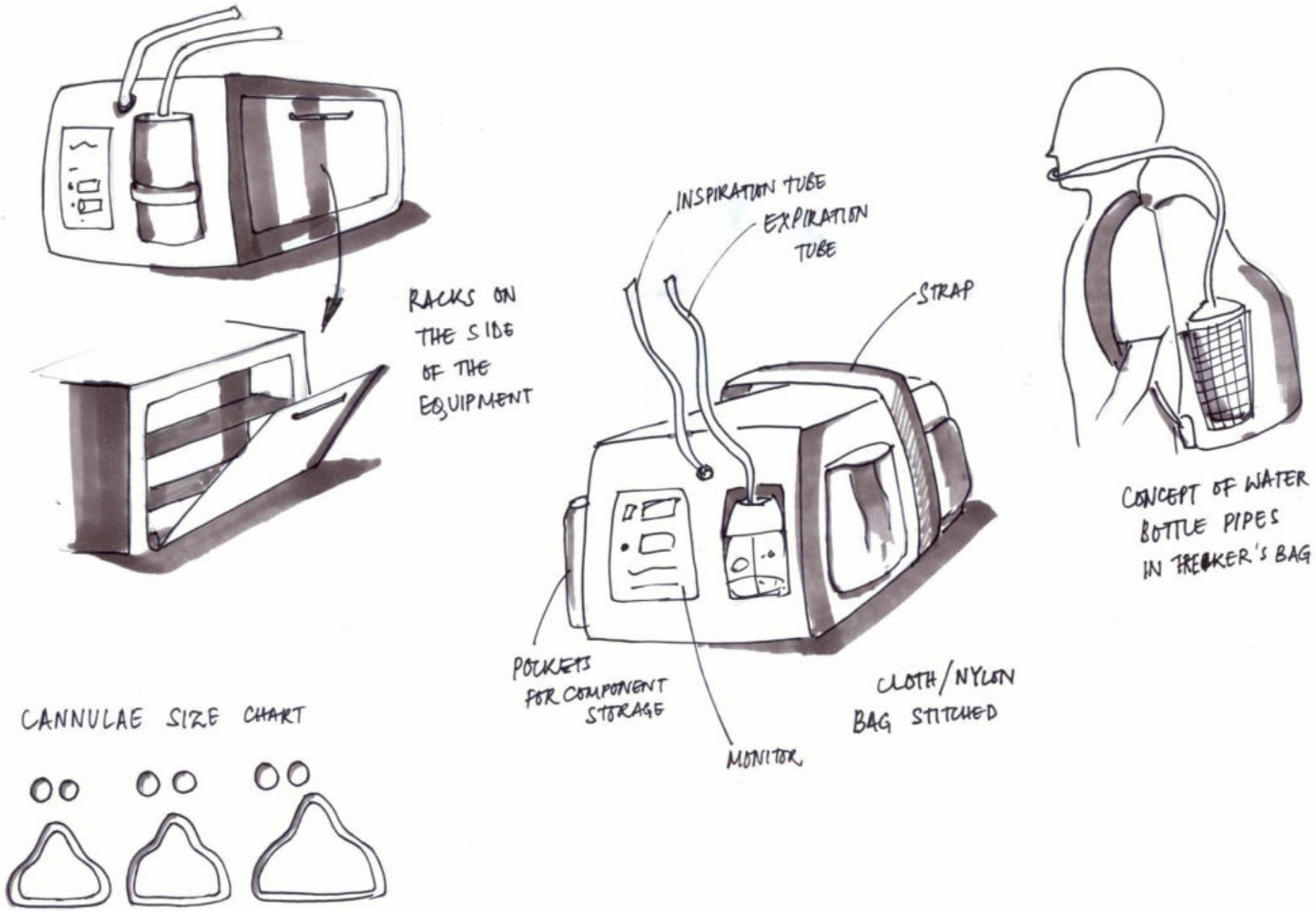

Ways of storing the other equipment like the user interface, pulse oximeter, tubes for intubation, intubation assiter etc.

## Ideations based on Separate subsystem - cap

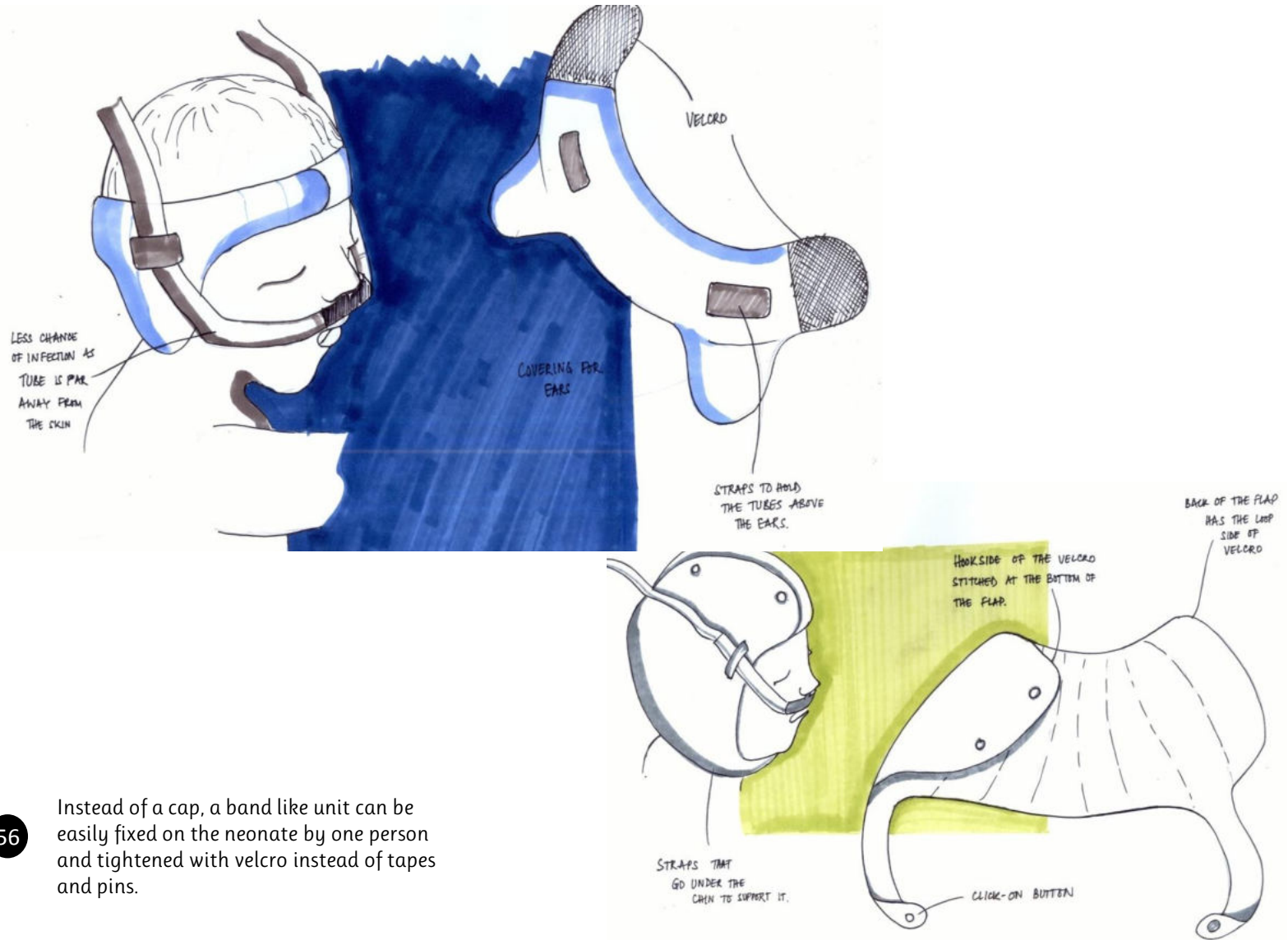

56

Instead of a cap, a band like unit can be easily fixed on the neonate by one person and tightened with velcro instead of tapes and pins.

# Ideations based on Separate subsystem - compact

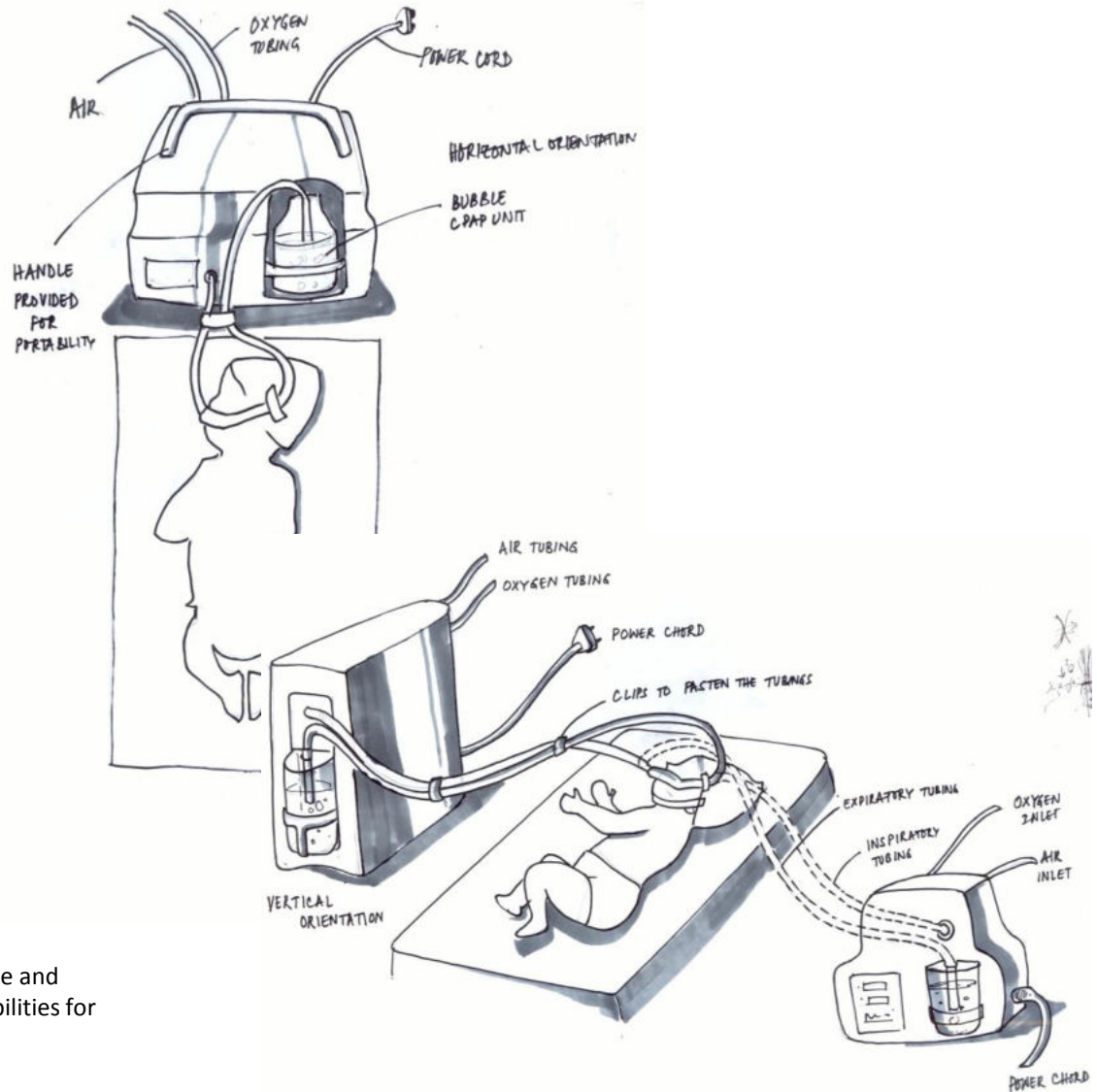
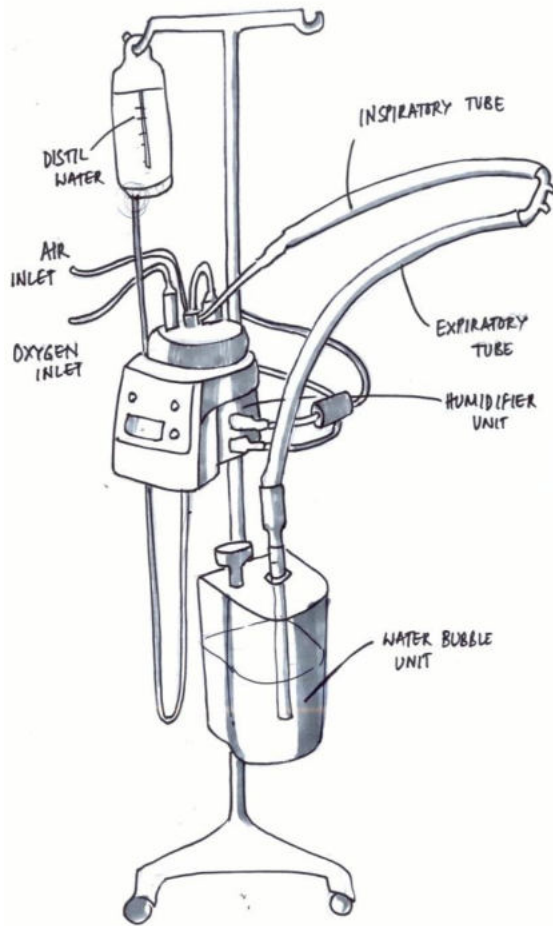

57

Picture on the left is of a standard device and the ideations on the right are the possibilities for compactness.

Ideations based on orientation

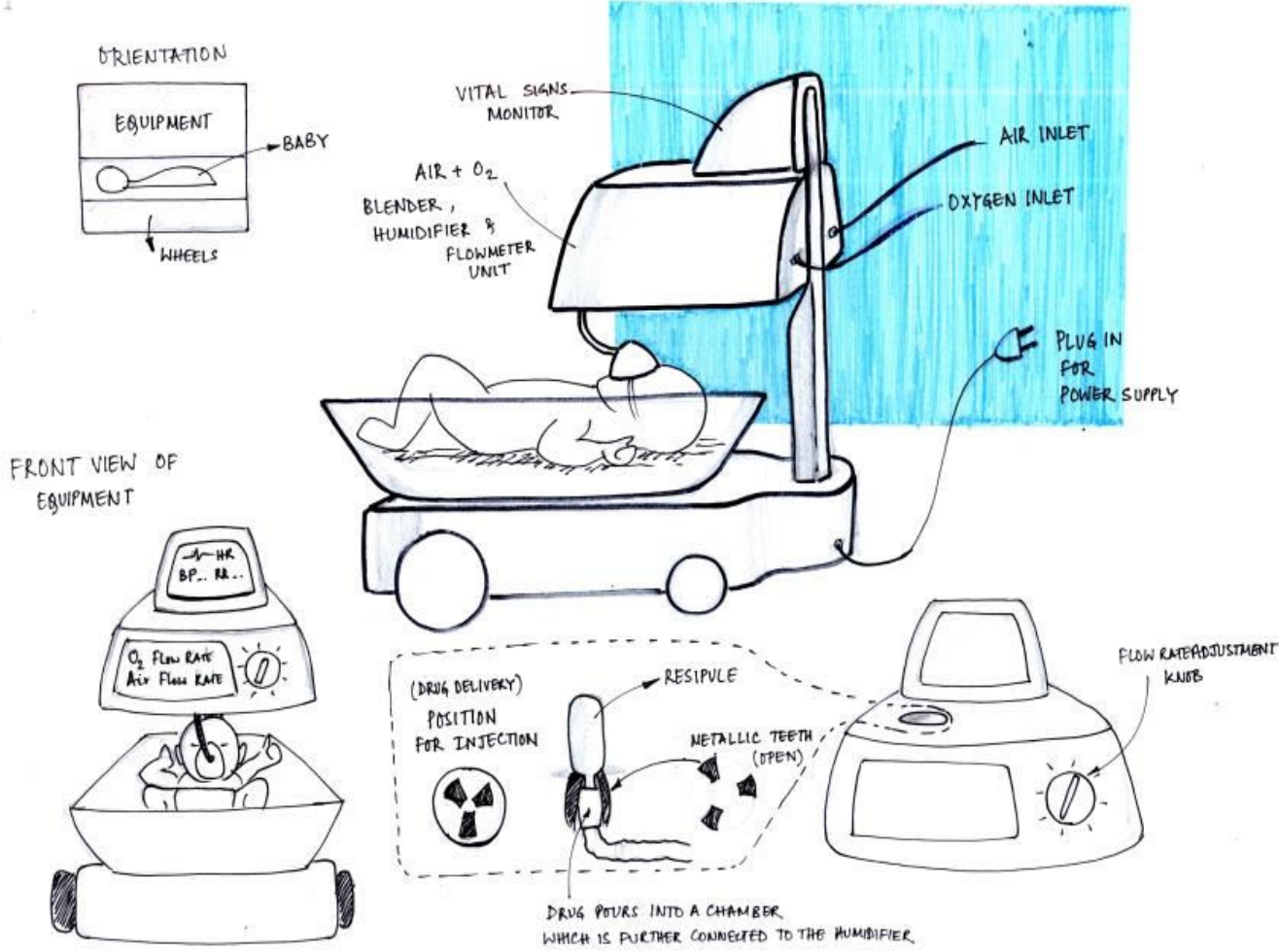

Ideations based on orientation

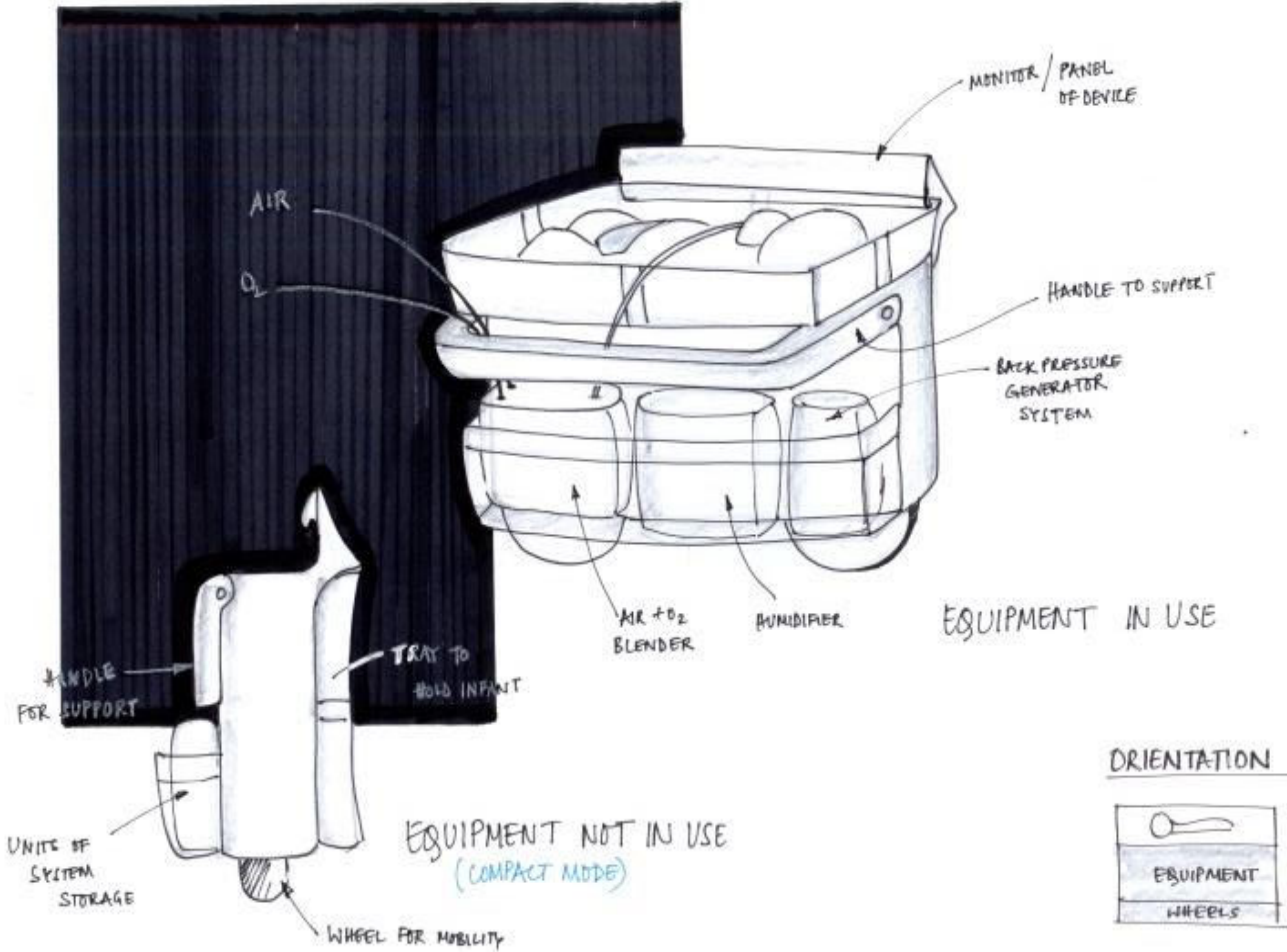

59 Note that the form shown is just for representation. Here the casing approach was being looked into where the equipment subsystems can be separately kept for ease of use/maintenance

Ideations based on orientation

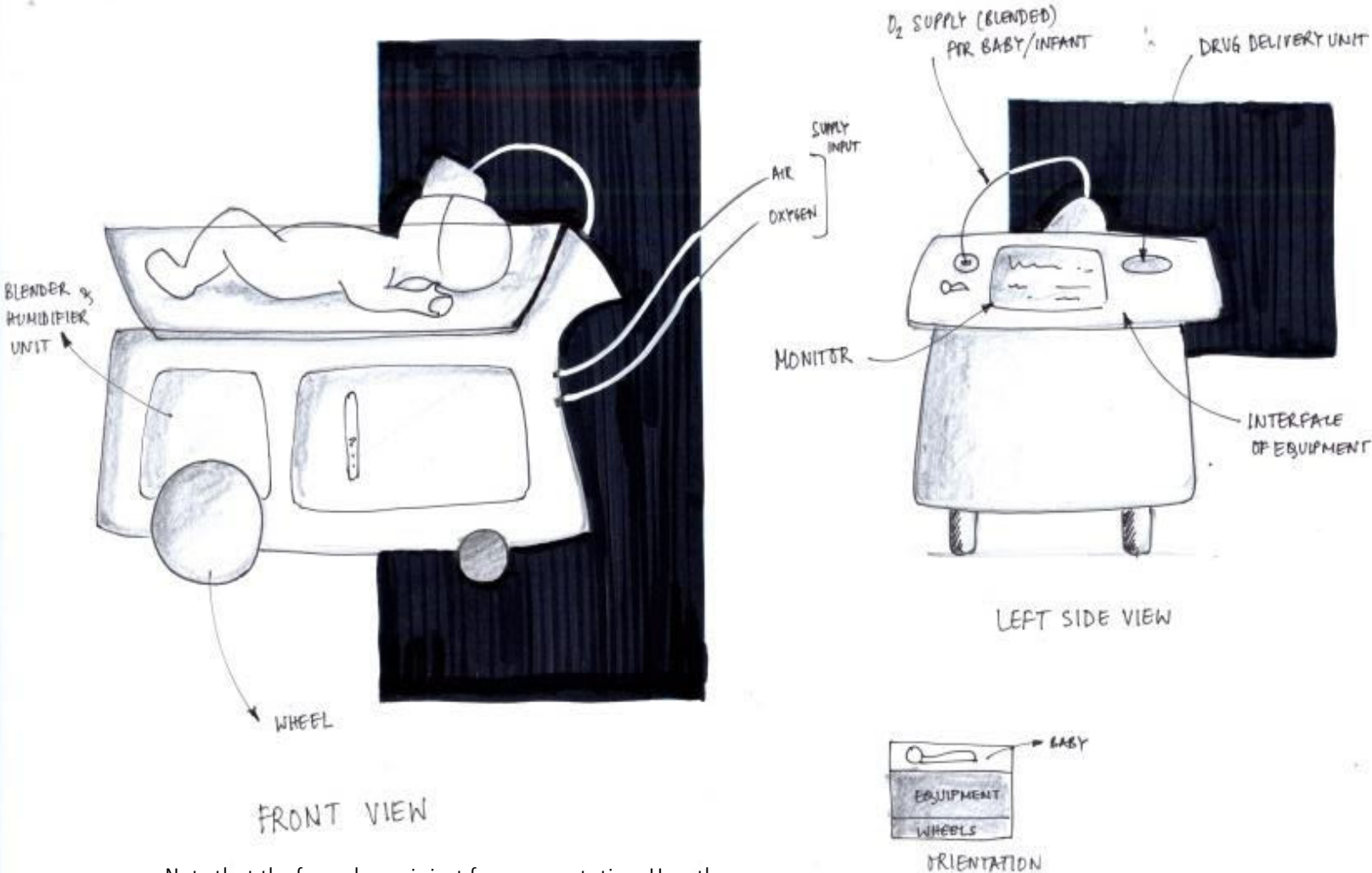

60

Note that the form shown is just for representation. Here the trolley approach was being considered to keep the baby and the equipment in one unit which is easily portable.

# Inside ambulance – equipment available and future possibility

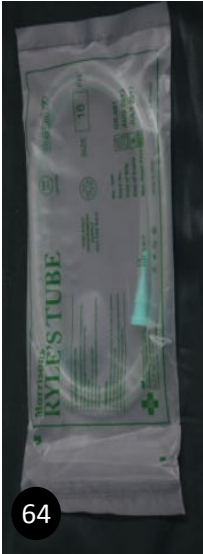

## Role play with test rigs



71

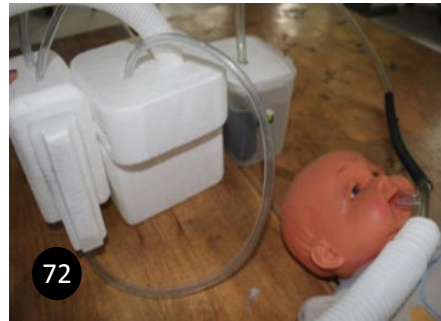

72



73



74

Fig 71-74 show the possibilities of orientation (water container should be at nose level or below) to see how compact can a system get if the subsystems were of standard dimensions. The inference from the role-play was that the space occupied by the standard equipment would remain within 400mm in length, 350 mm in breadth and 200 mm in height. Fig 73 shows that the water container is above the level of the baby's nose hence this orientation should not be considered to prevent back suction of water into the infant's lungs.



75

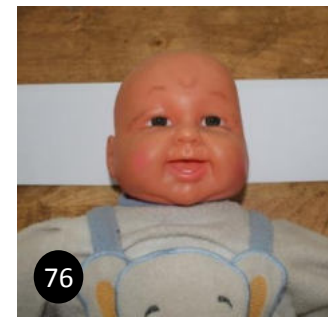

76



77

Fig 75-77 show how the head dimensions are necessary for a cap like unit. But if a band like interface (fig 76, 77) is used the dimensions need not be taken, an adjustment below the chin with a Velcro would fit all head sizes.

# Direction from Ideations

After making possible solutions for the problems inferred, ideations were clustered on the basis of 3 directions. The CPAP device can be used in 3 possible areas.



## A Inside hospitals

The aim is to reduce the clutter surrounding the equipment which is currently present



## B During transit

In emergency delivery situation- the aim is to make the device suitable for installing inside a vehicle.



## C In local clinics

Local clinics are more accessible to the people in very small towns and villages

---

From the research papers and from the visit to the various levels of hospitals, it was decided to go ahead with **option C** which is to modify the

CPAP device for a local clinic set up. Albeit, the other two are also challenging areas to work on, the need to have an

independent set-up in a local clinic which is the first touch point for the people in case of any emergency situation is much greater than the rest.



# Concept-1

The first concept is to have the entire set-up as a covered casing which is easily portable. This will house the subsystems like the air compressor unit, blender unit, the humidifier and the water-bubble unit under the front cover as shown. Here the storage space is very small for the connecting tubes but other equipment like the nasal cannula, the head-neck support etc. can be stored.

This set-up would be placed on a flat surface close to the infant's bed inside the clinic.

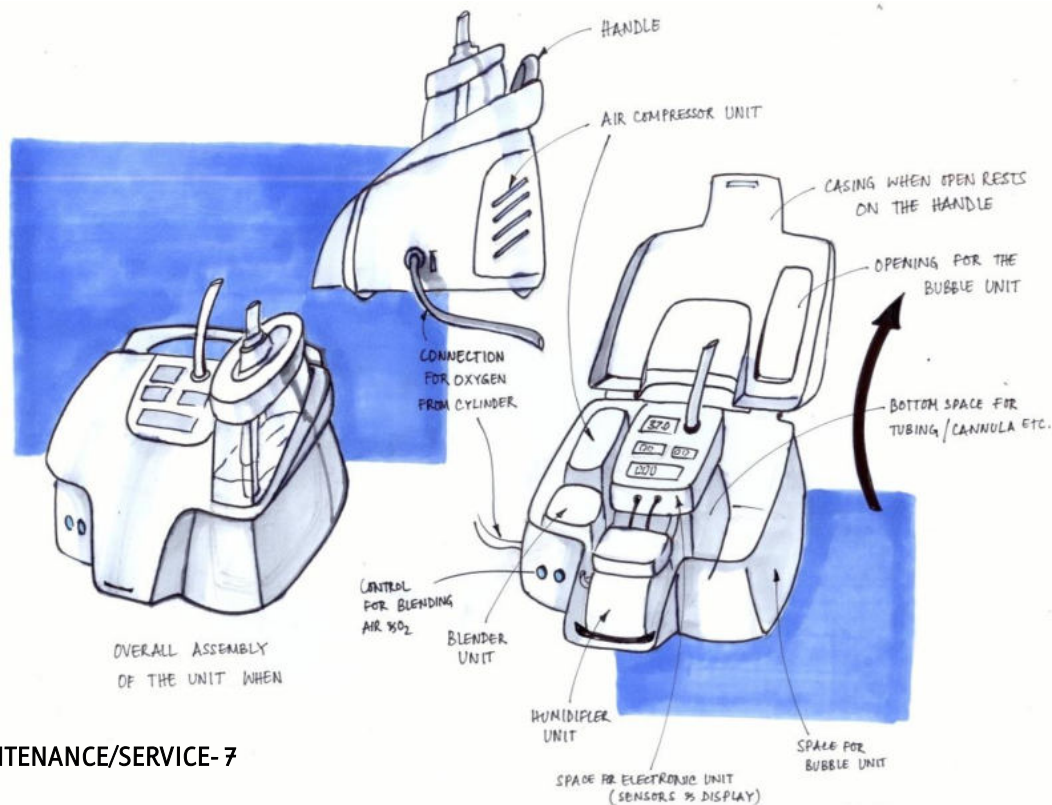

## COMPACT-7 PORTABLE-7 EASE OF USE-8 MAINTENANCE/SERVICE-7

### Advantages:

- 1- Easy to carry and can be placed anywhere
- 2- Front open cover
- 3- Accessibility to internal components for maintenance
- 4- Least visibility and posture issue(for the user)
- 5- Handles on the side for carrying the unit

### Disadvantages:

- 1- Use of both hands to carry the unit around
- 2- Cannot be placed at a position above the bed
- 3- The bottle needs to be removed for opening the front cover
- 4- Weight of the system needs to be considered for moving around
- 5- Visibility of the controls should be clear
- 6- Separate oxygen cylinder source need to be attached
- 7- The unit needs to be kept near a power source
- 8- Comparatively less space to store the pipes/cannula/other imp. Equipment

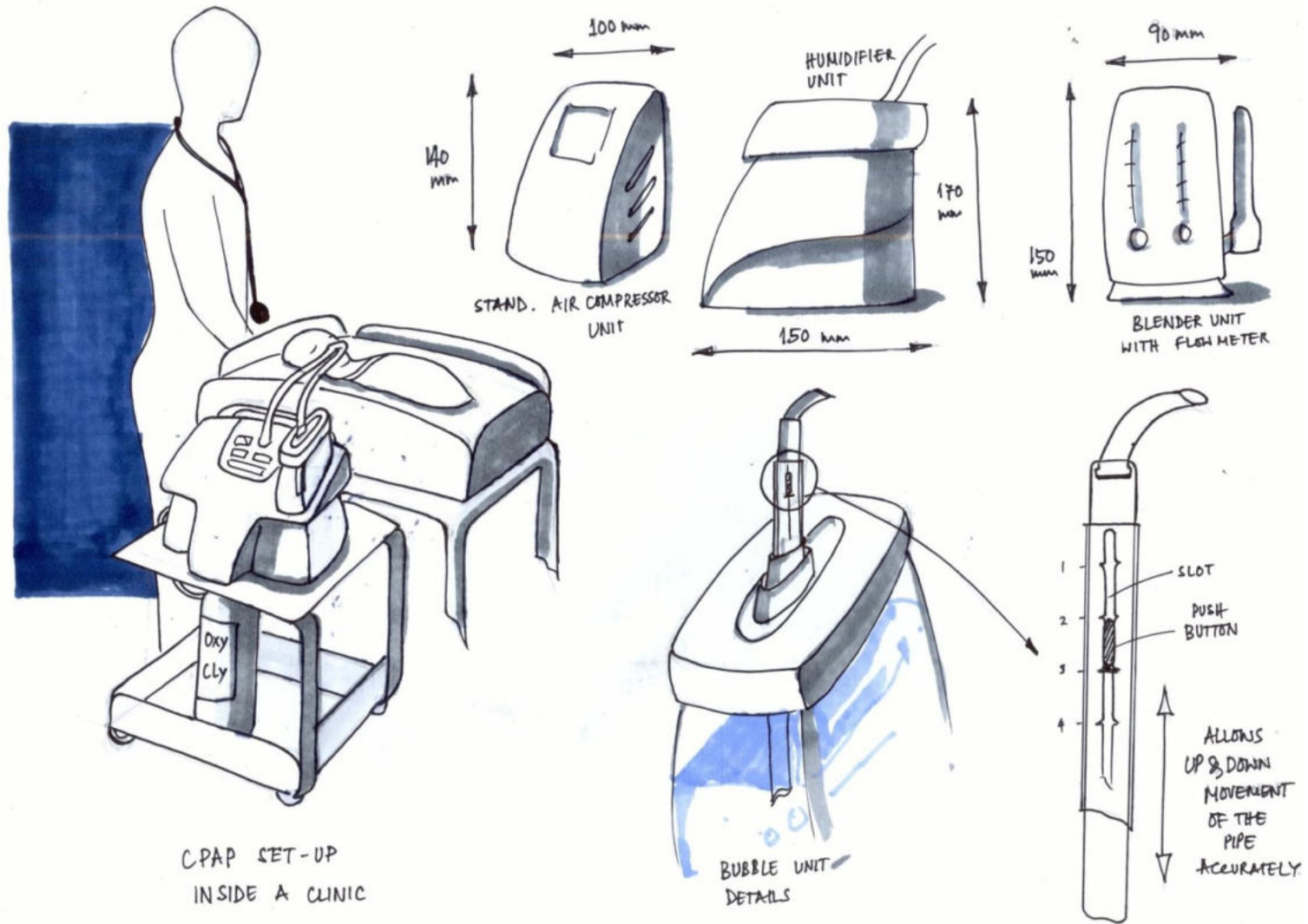

Picture shows how the device would be used in the clinic environment. The dimensions of the standard subsystems are as shown on the top and top left corner.

The bubble unit has a modification in the stem which is tightly fixed onto the cap while the stem is adjusted to the required height by using a push button that fixes into a slot once the height is set.

## Concept-2

Most clinics have a bed with railing on the head and foot side. This product's casing is meant to be fixed on one of these rails and used. The subsystems mentioned earlier would have a bag like outer unit which is detachable from the casing and can be carried to another location. The casing unit has a storage rack at the bottom which is used to store the tubing and interface components.

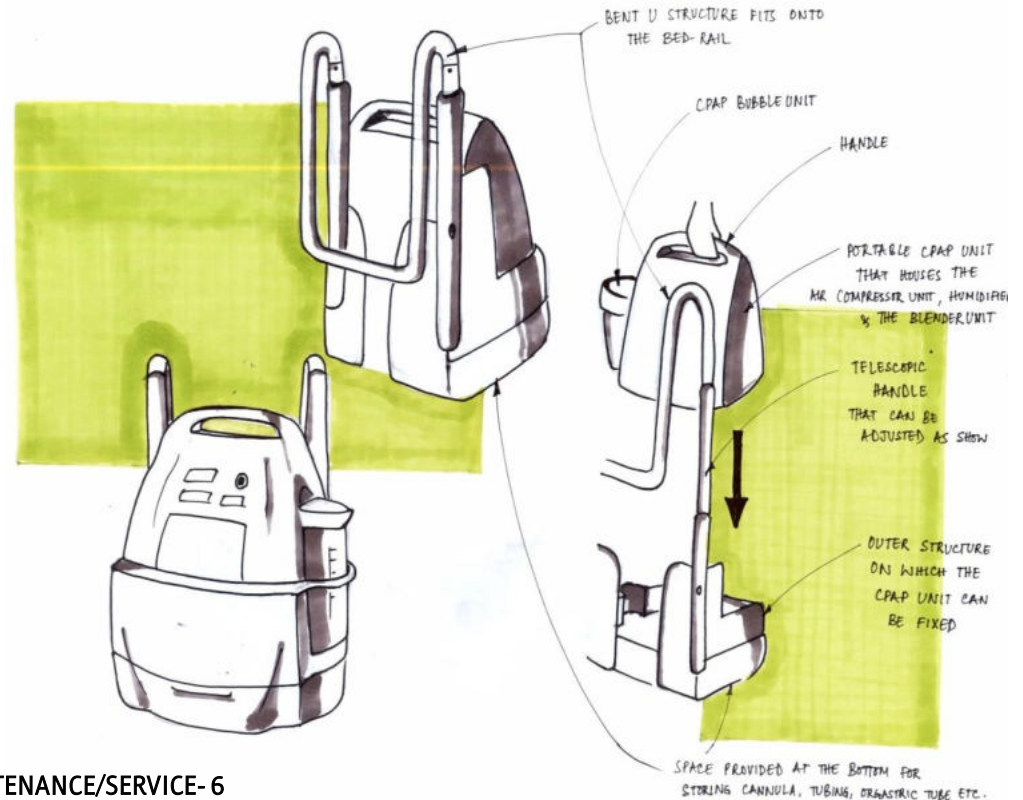

COMPACT-7 PORTABLE-6 EASE OF USE-6 MAINTENANCE/SERVICE-6

### Advantages:

- 1- Flat surface not required for keeping the unit
- 2- Telescopic handle for adjustment of the height
- 3- Larger space for storage of the equipment at the bottom drawer
- 4- Can be carried with one hand when not placed inside case.

### Disadvantages:

- 1- Not applicable for beds without rail
- 2- Extra parts - telescopic handle - chances of failure
- 3- Visibility and posture issues
- 4- Weight factor needs to be considered to hang out over the rail

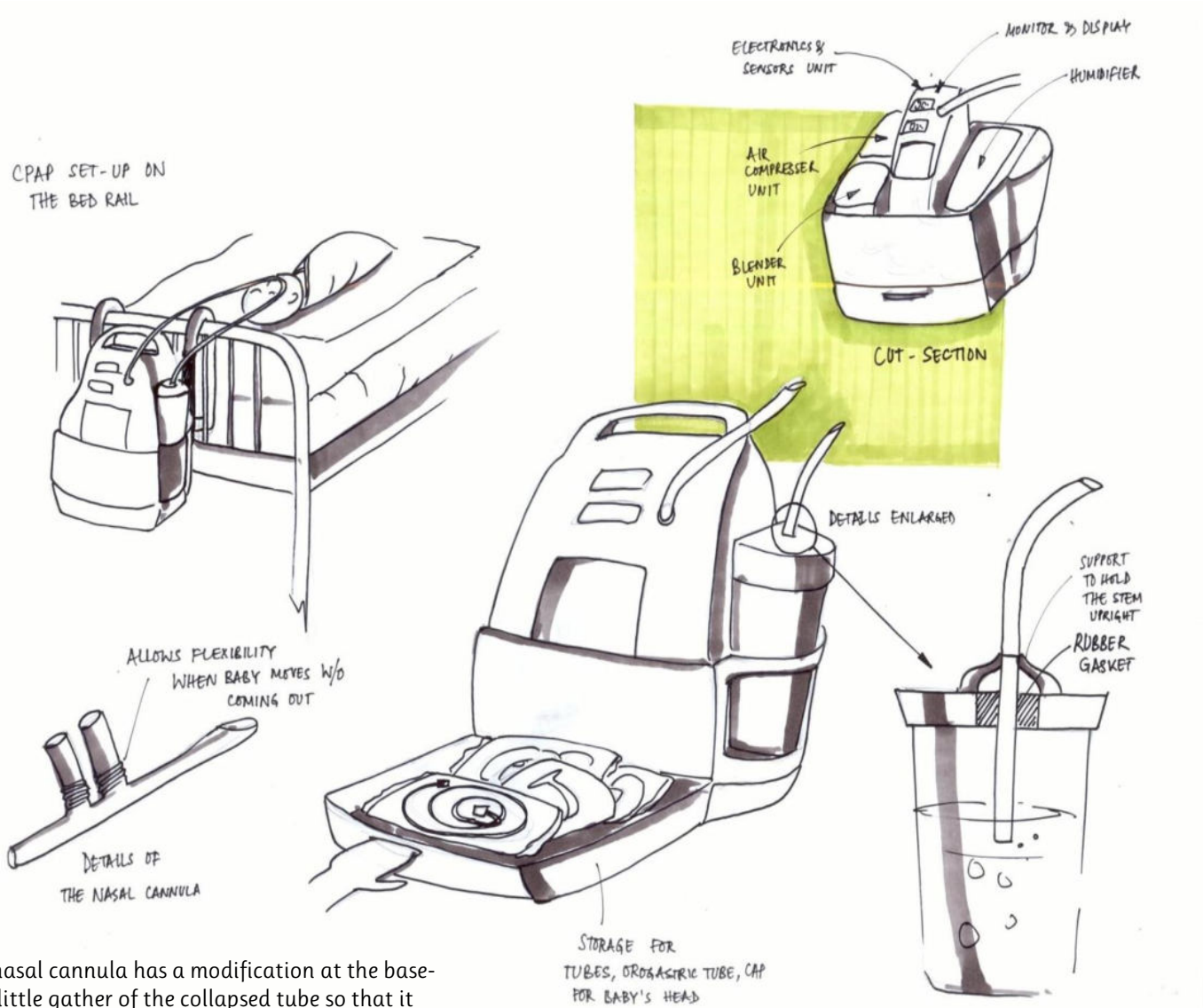

The nasal cannula has a modification at the base. A little gather of the collapsed tube so that it allows for flexibility when the baby moves its head and it does not pop out.

## Concept-3

This concept explores the portability aspect more since it has wheels. There is a unit at the base which holds the entire subsystem along with other provisions like the oxygen cylinders, additional components and there could be an addition space managed for power back up. The unit can be moved easily around by one staff with the baby on cpap.

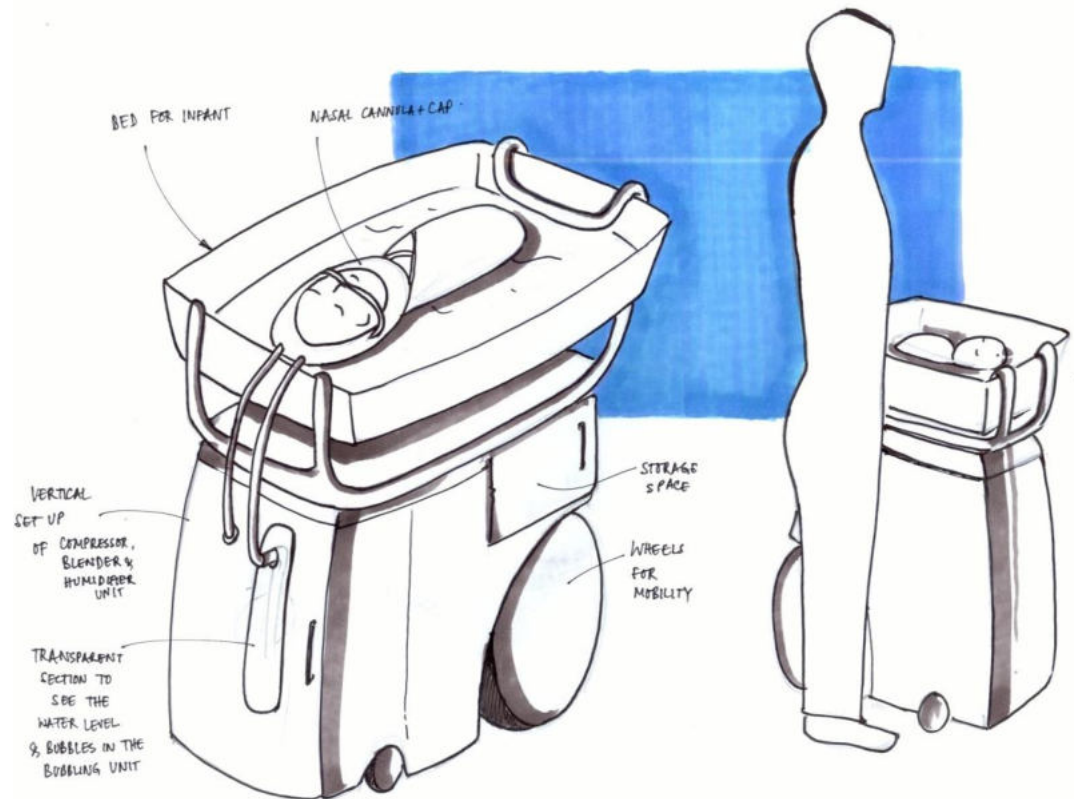

**COMPACT-8 PORTABLE-8 EASE OF USE-7 MAINTENANCE/SERVICE-7**

Advantages:

- 1- One compact unit on wheels
- 2- Better space allocation for other components within
- 3- Better mobility- within the room/outside/to the emergency van
- 4- Power back-up unit may/can be provided(secondary wishlist)

Disadvantages:

- 1- Need to have controls/monitor units at working height
- 2- Visibility and Accessibility issues need to be looked into
- 3- Motion should not affect the units inside

Picture shows the head and neck support for the baby and how the nasal cannula rests inside the casing and takes its support instead of it being attached on the baby's head

Picture on shows the possible way of storing the equipment inside making it neat and compact. There is less vial clutter and it is more organised.

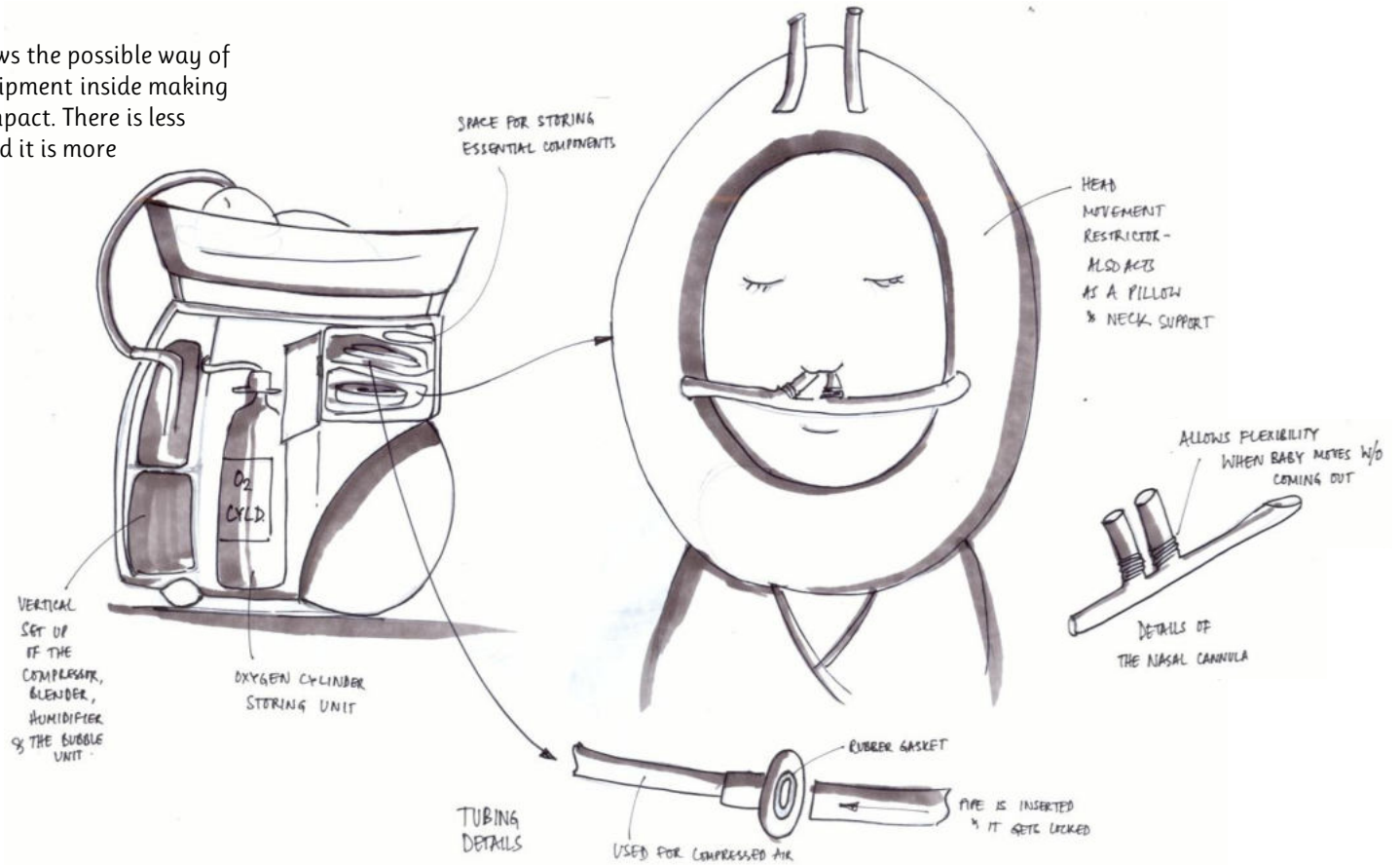

One of the tube connection detail which is easy to lock and remove without chances of it coming off

# Concept Evaluation

Defining the words in the brief:

**Compact** - condensed/packed layout/ concise packaging or closely packed together.

**Portable** - able to be easily carried or moved about especially because being of a lighter and smaller version than usual. Managable/ handy/ convenient/ cartable/ haulable

**Ease of Use** - make better to handle/soften the severity of use or complexity

**Maintenance free** - technologically repairable, diminish system failures due to subsystem failure, standard components are replaceable off -the-shelf.

	Concept 1	Concept 2	Concept 3
Compact	7	7	8
Easy to use	8	6	7
Portable	7	6	8
Maintenance free	7	6	7

The numbers marked on a ten point scale under each concept was based on discussion with the doctors and the insights gained from the field visits.

Since **concept 3** scores the highest rating as an average, it will be considered as the final concept for this project.

# Concept Selected



The entire set-up showing the scale of the model.

Section showing the space for CPAP equipment, component storage and cylinders space. There is a possibility of power back-up unit if space is efficiently utilized.

This is a representative model of the final concept. The form and aesthetics will be further explored.



# Test rig of the Concept

After the final concept was selected, a quick test rig was made out of bamboo, cardboards and foam boards to test the ergonomic factors like working height, working area etc.

Position, Orientation, Usability and visibility testing of the interface was also carried out to understand the various possibilities and the problems associated with each.

The temporary test rig was then measured for various dimensions as follows.

L: 680 mm W: 460 mm H: 1000 mm

The insights obtained were:

- The baby's orientation was a key issue since the ease of accessibility matters here and from doctor's opinion keeping the head toward the accessible area of the doctor was important. In fact having the whole body accessibility would be much preferred.
- The interface should not restrict access



Fig 78 displays the entire structure of set up  
Fig 79 accessibility of the interface from the head side  
Fig 80 working height and area testing



Fig 81 - user is working on fixing the baby's interface but his attention is caught by the signals on the interface  
Fig 82 - bringing the interface on the side makes the user lift up his toes and work - very difficult posture to work in

Fig 83 - testing one of the interface layouts  
Fig 84 - accessibility from the front side - monitor interface may have an affordance of hand rest  
Fig 85-86 - testing the oxygen cylinder orientations- horizontal/vertical to understand ease of access, replacing and setting up connection.

# Form Exploration Constraints

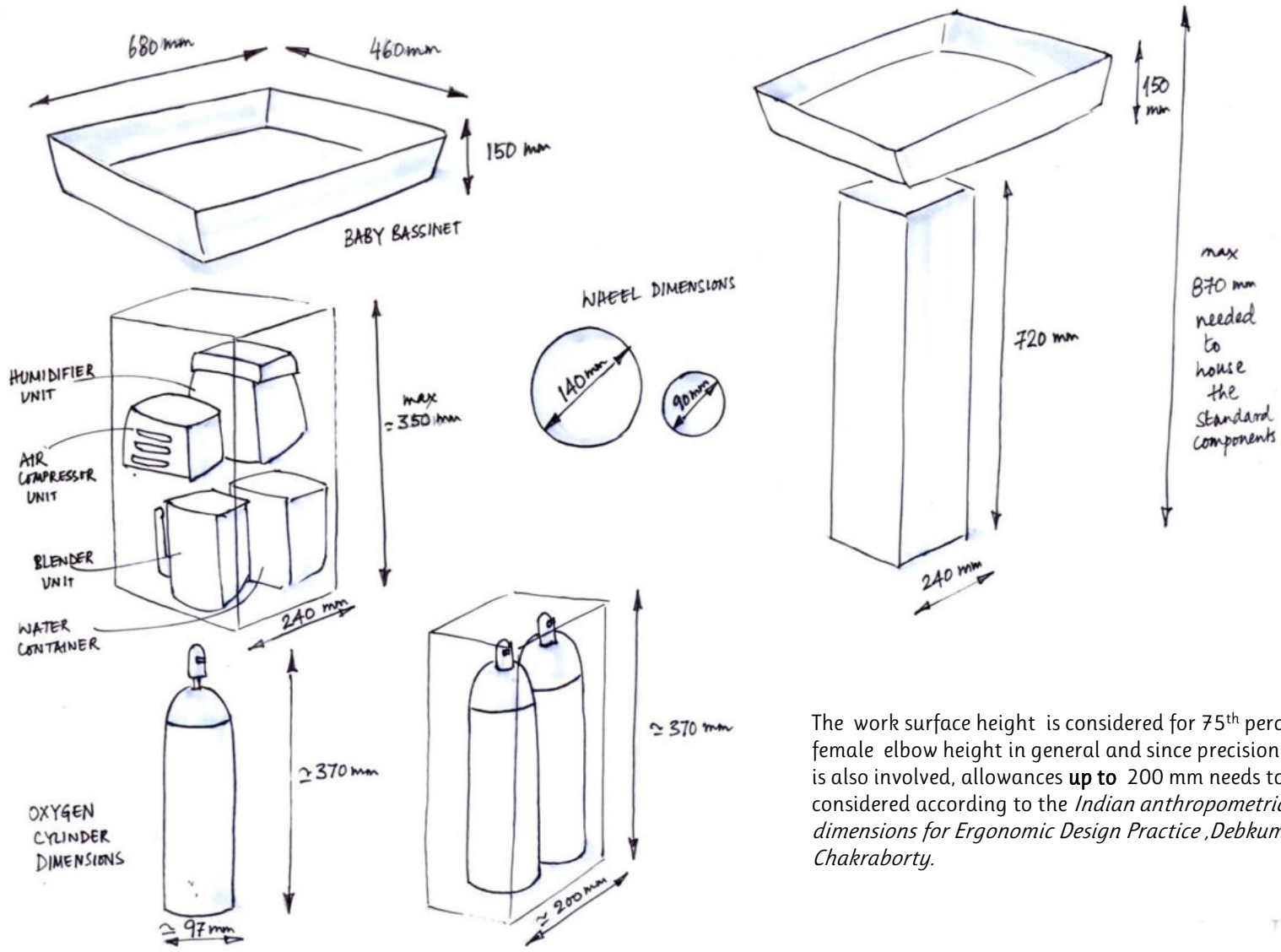

The work surface height is considered for 75<sup>th</sup> percentile female elbow height in general and since precision work is also involved, allowances **up to 200 mm** needs to be considered according to the *Indian anthropometric dimensions for Ergonomic Design Practice*, Debkumar Chakraborty.

# Initial Form Explorations

After determining the different component sizes to obtain the inside structural space, external features were added to the structure to get the sketched forms.

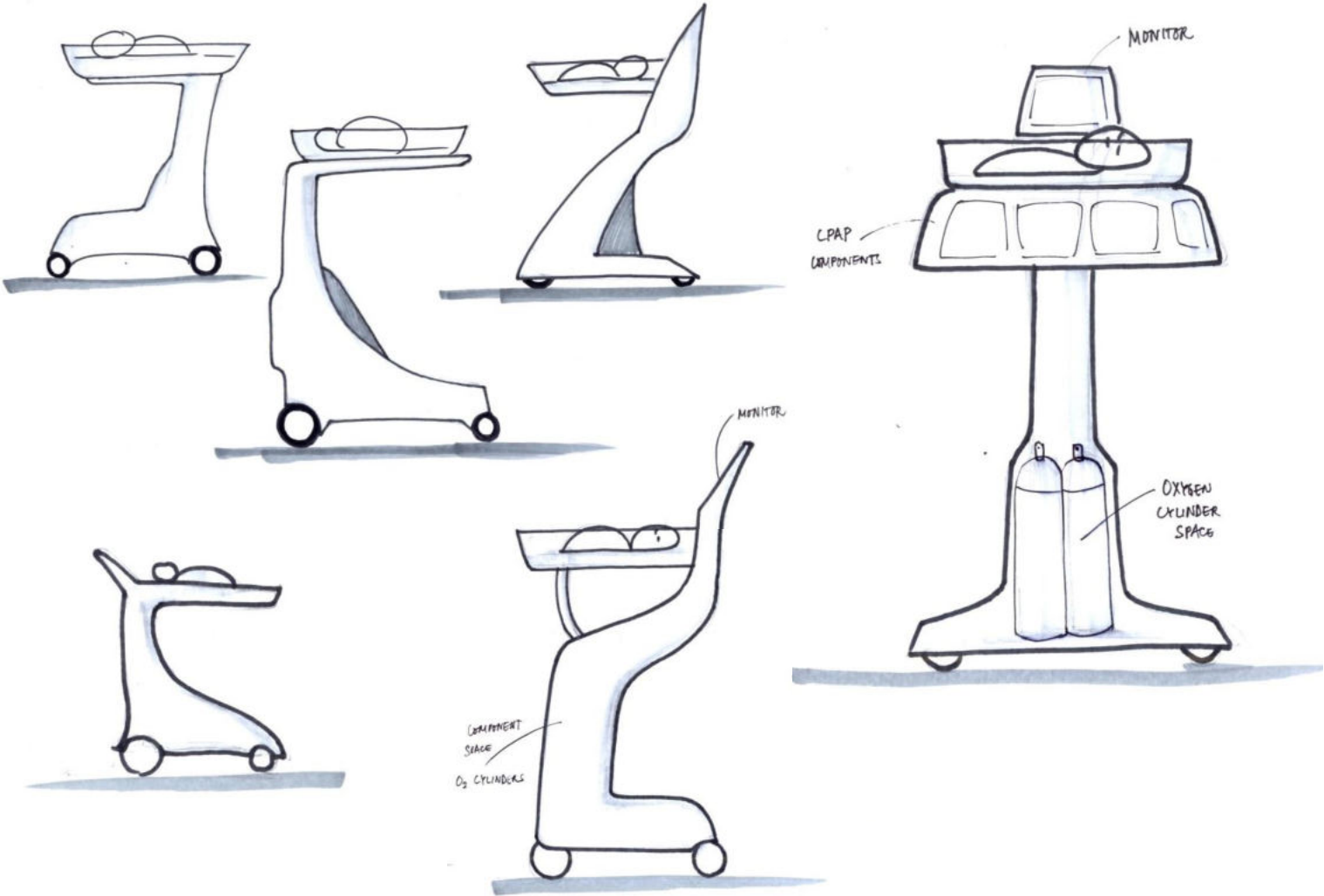

# Form Explorations

EQUIPMENT IN SCALE WITH HUMAN SIZE

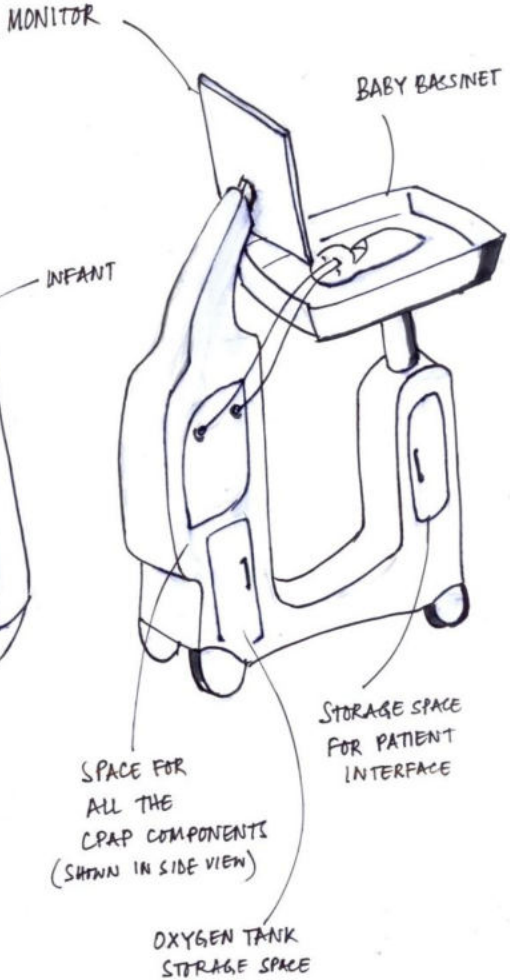
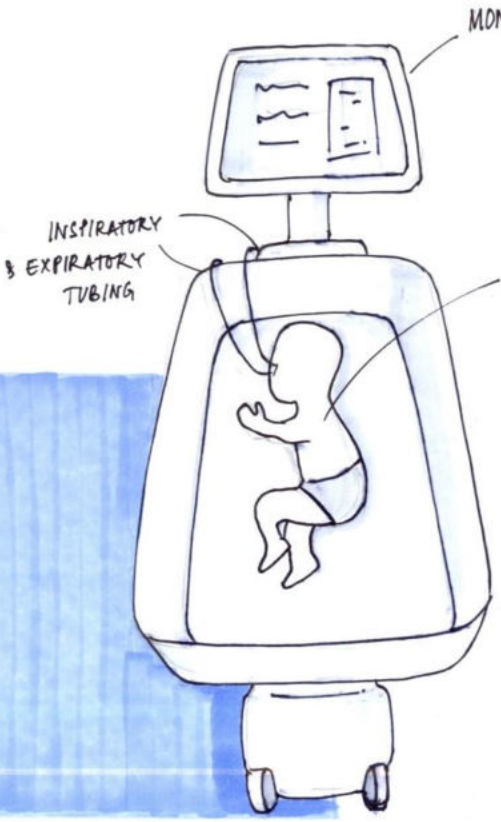
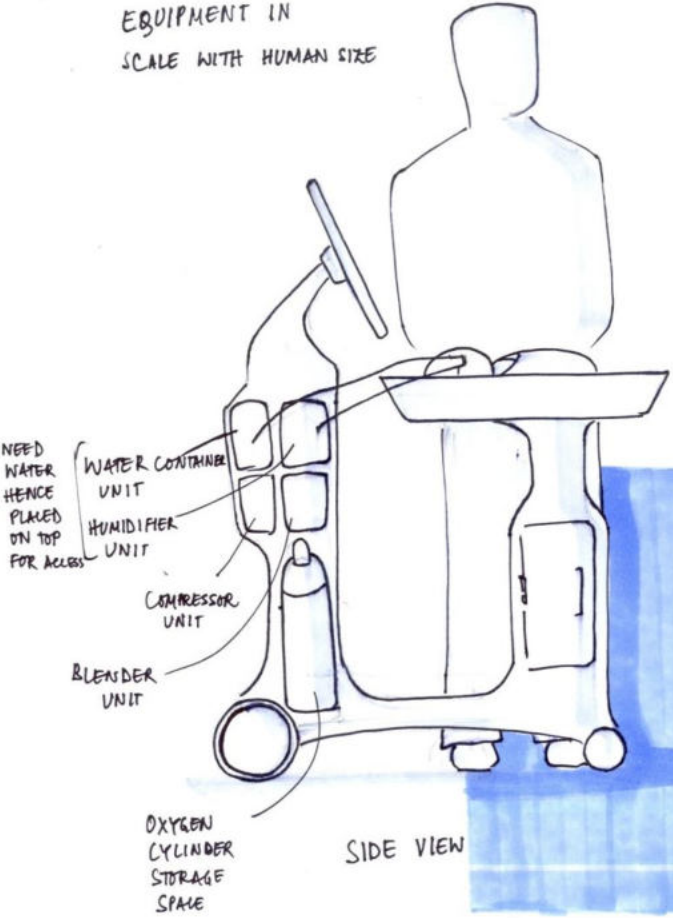

# Form Explorations

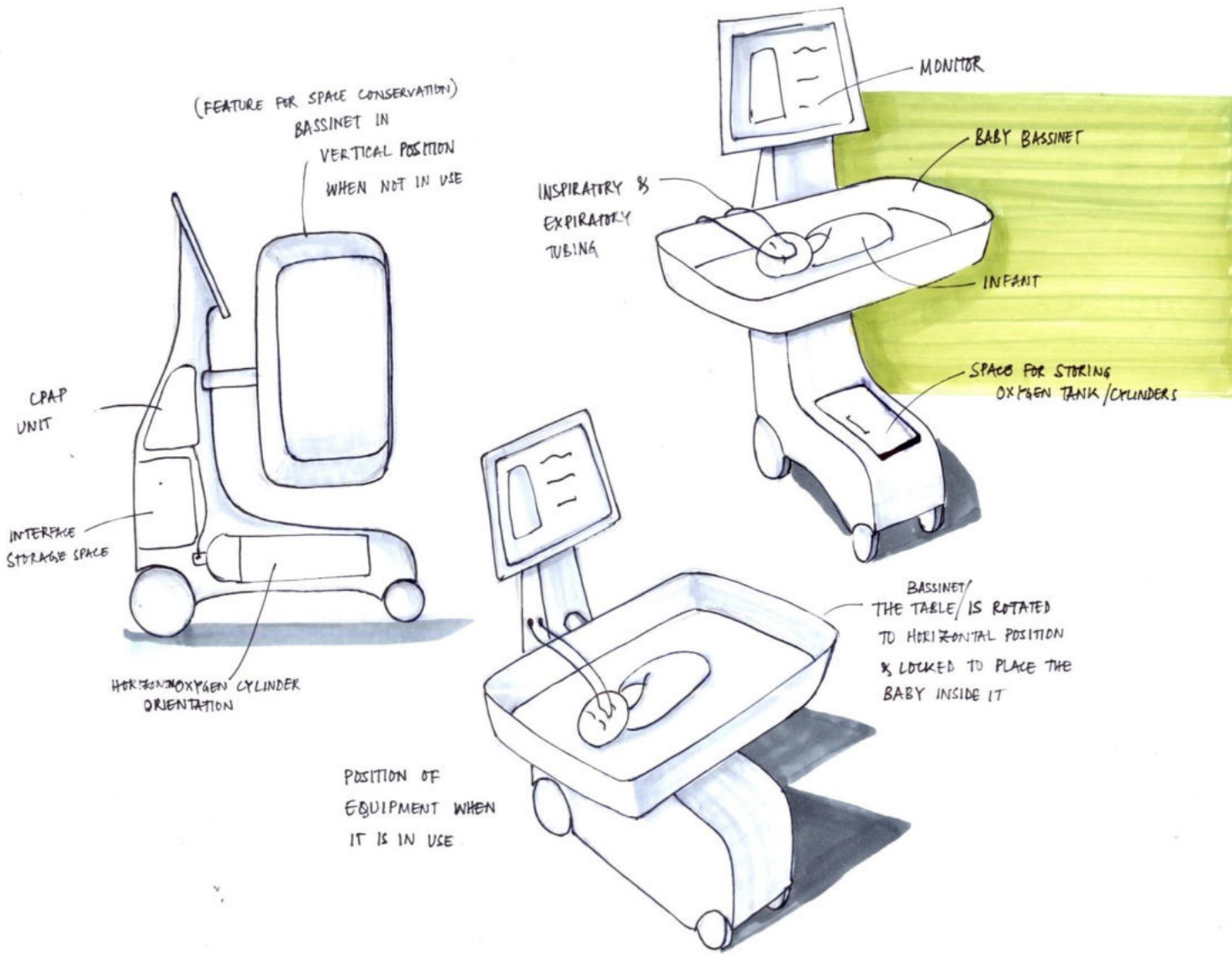

# Form Explorations

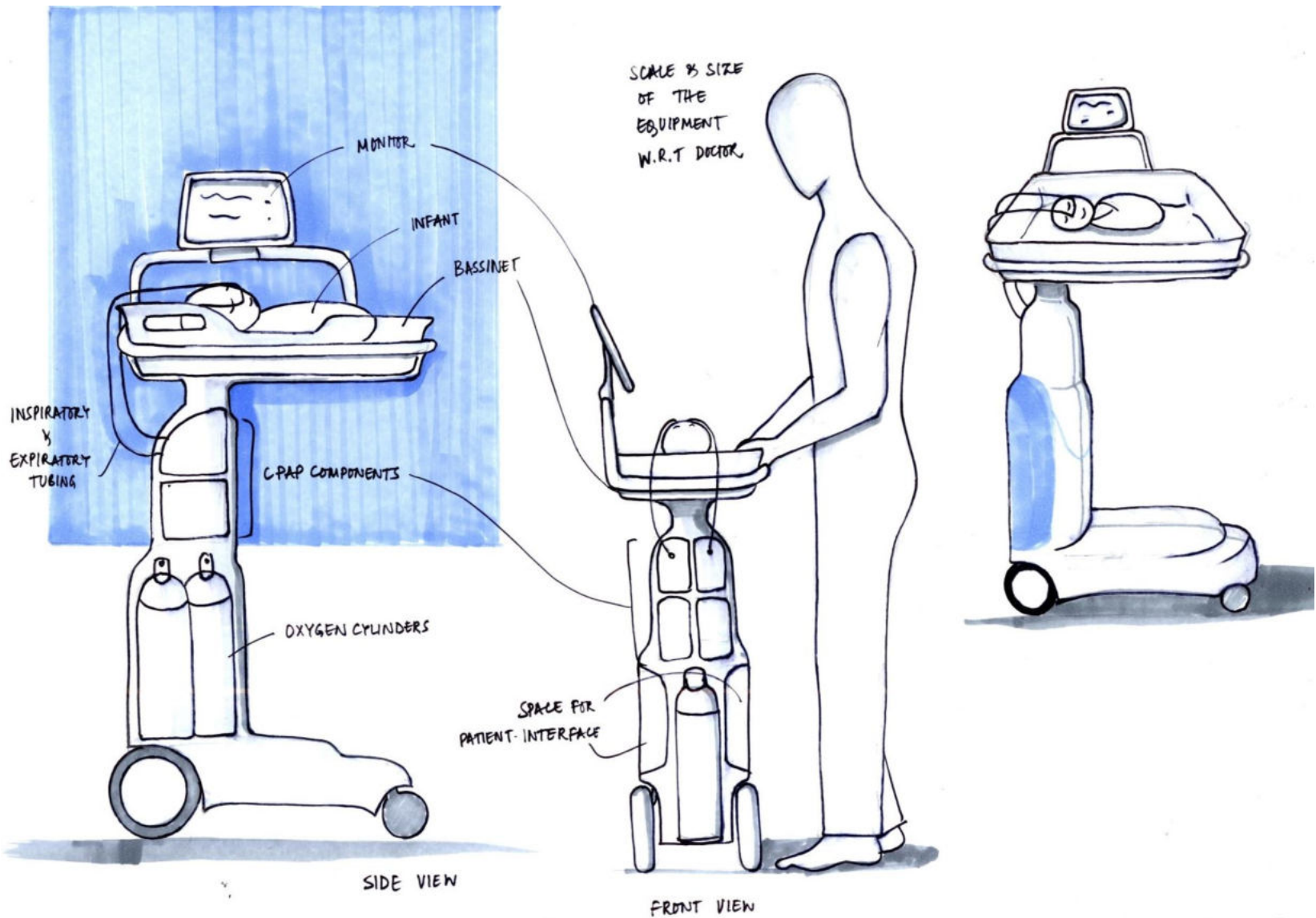

# Orientation possibilities with different subsystems

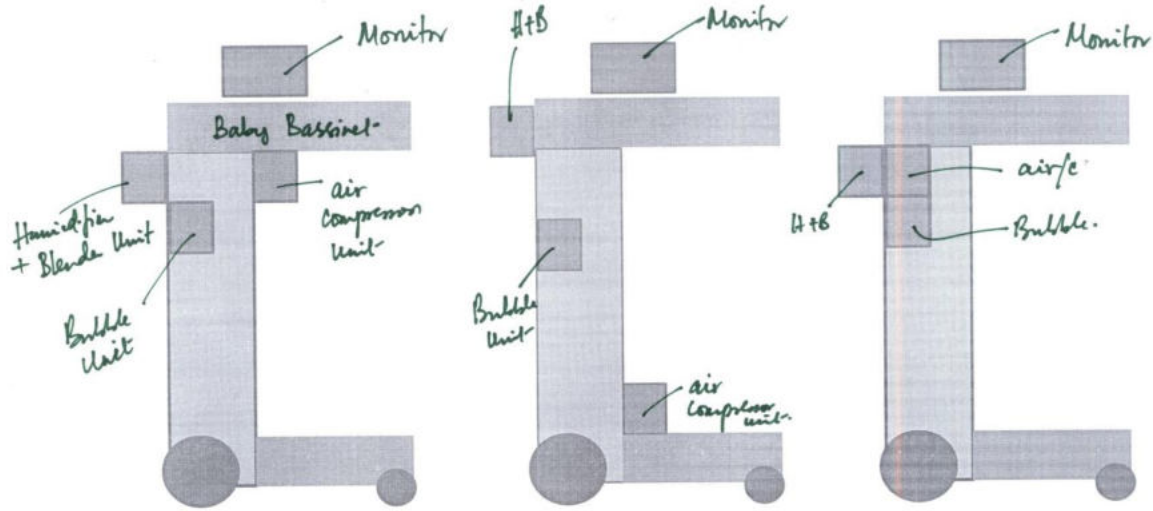

1

2

3

Possible Orientations of the Sub Systems

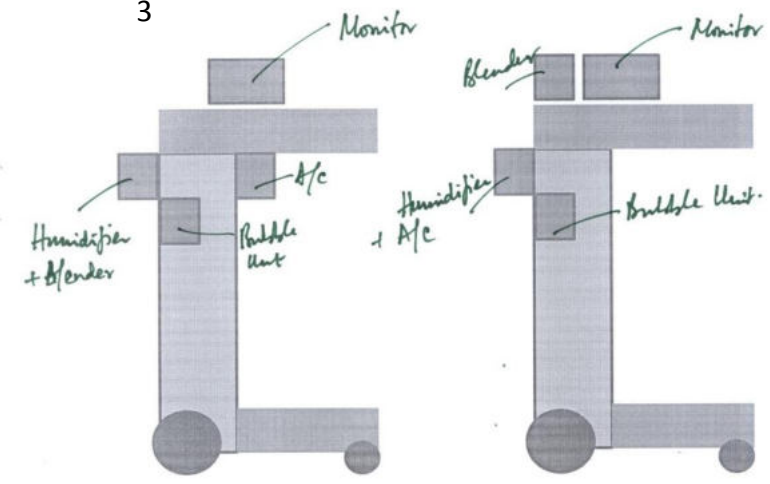

4

5

# Equipment with adjustable height and dimensions

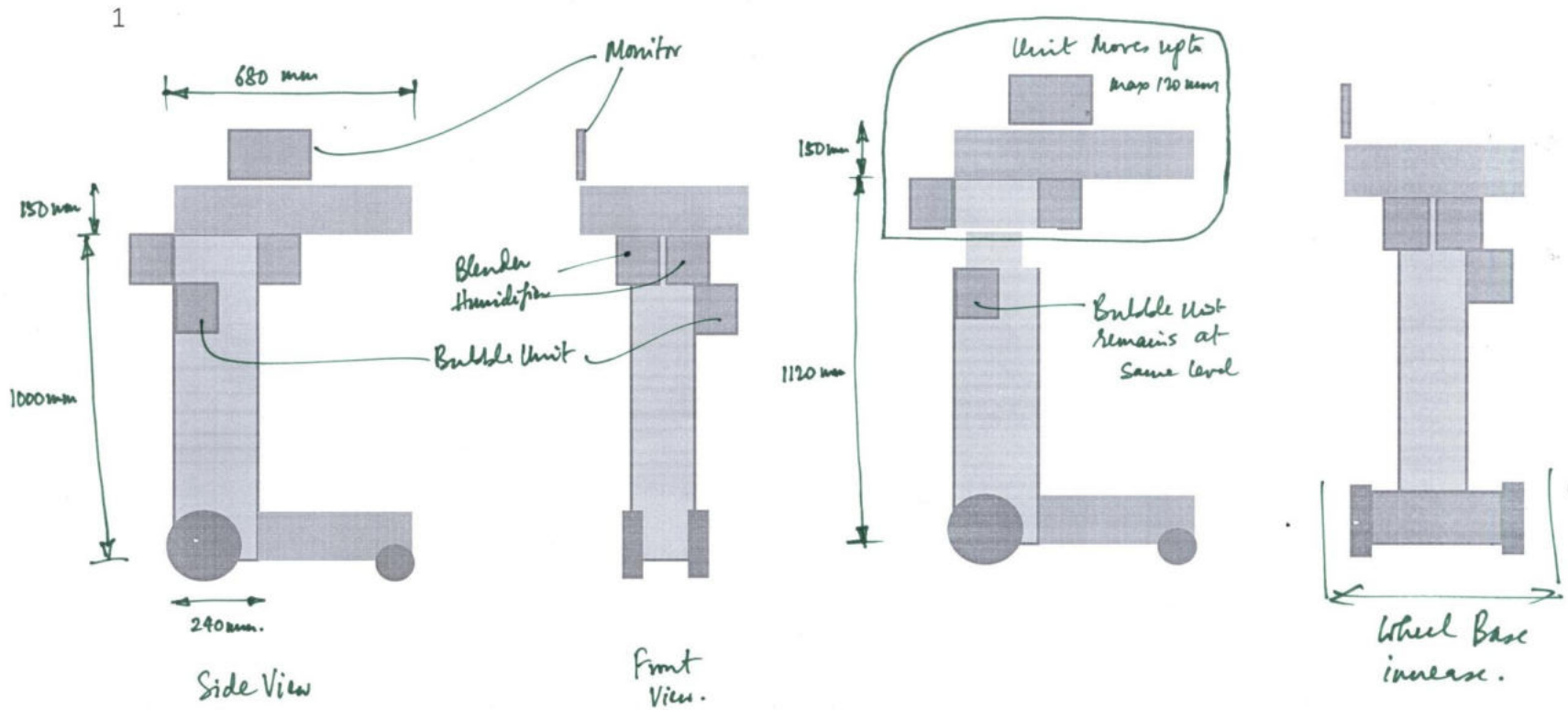

# Form exploration with Orientation - 2

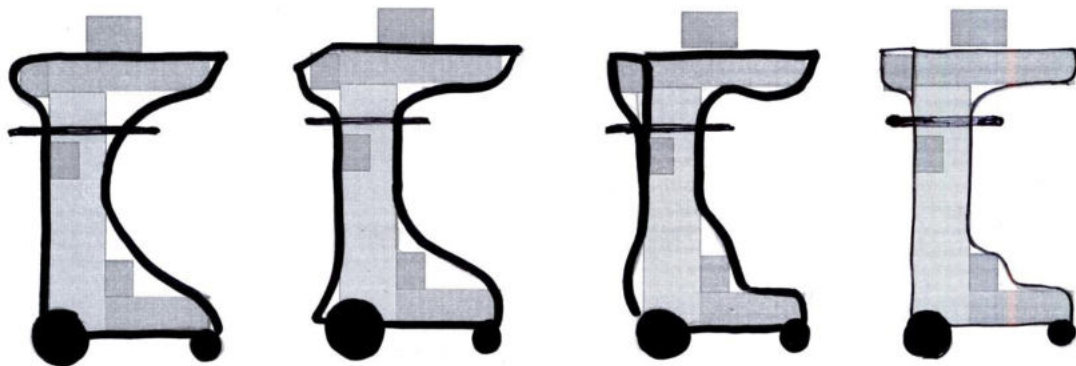
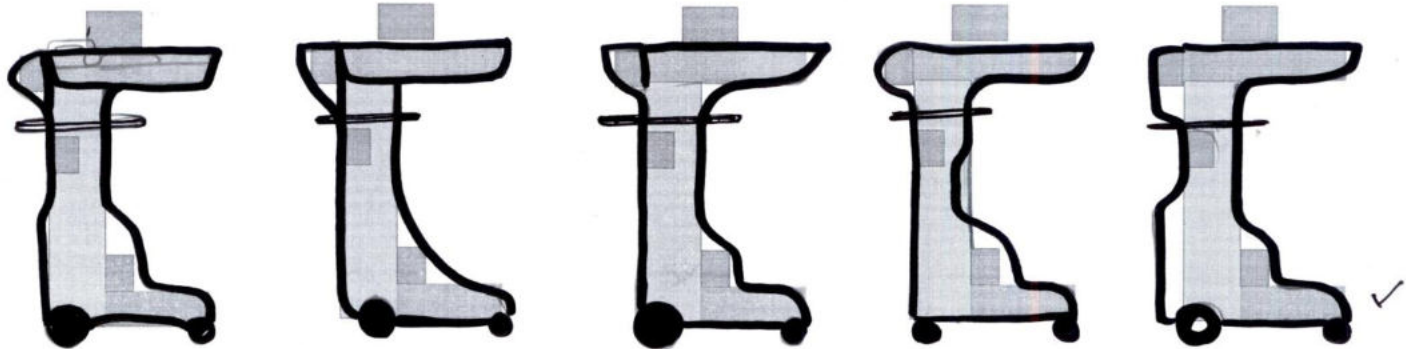

# Form exploration with Orientation - 2



# Final Design derived from Orientation 2 & 5

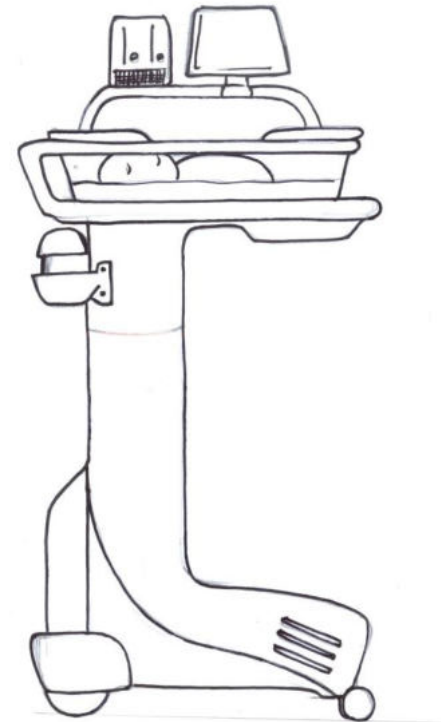
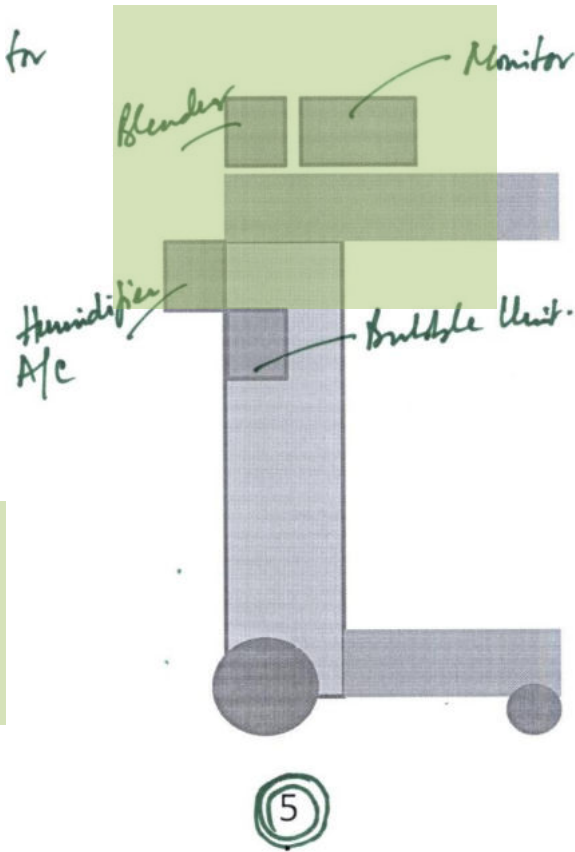
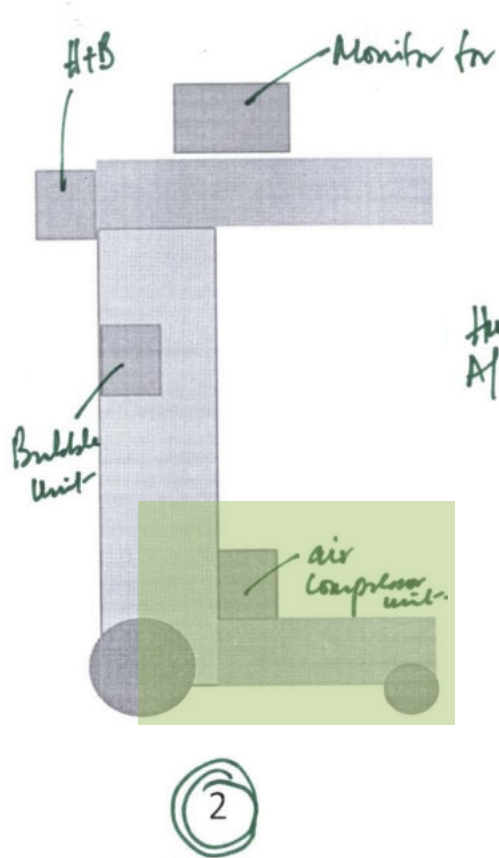

# Final Details with internal and external components

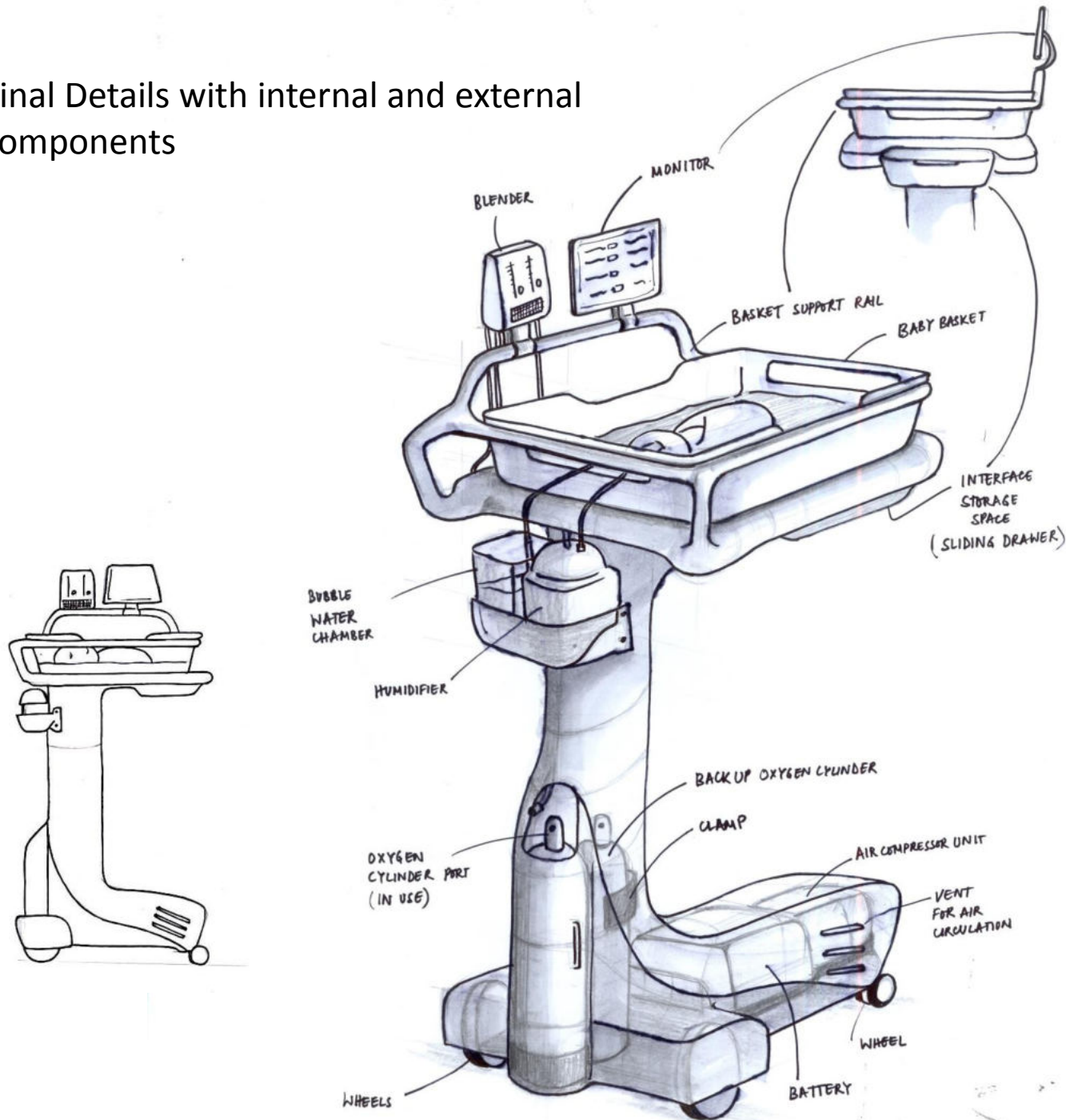

# Test Rig of the Final Design



# Test Rig of the Final Design



# Final Render



# Final Render

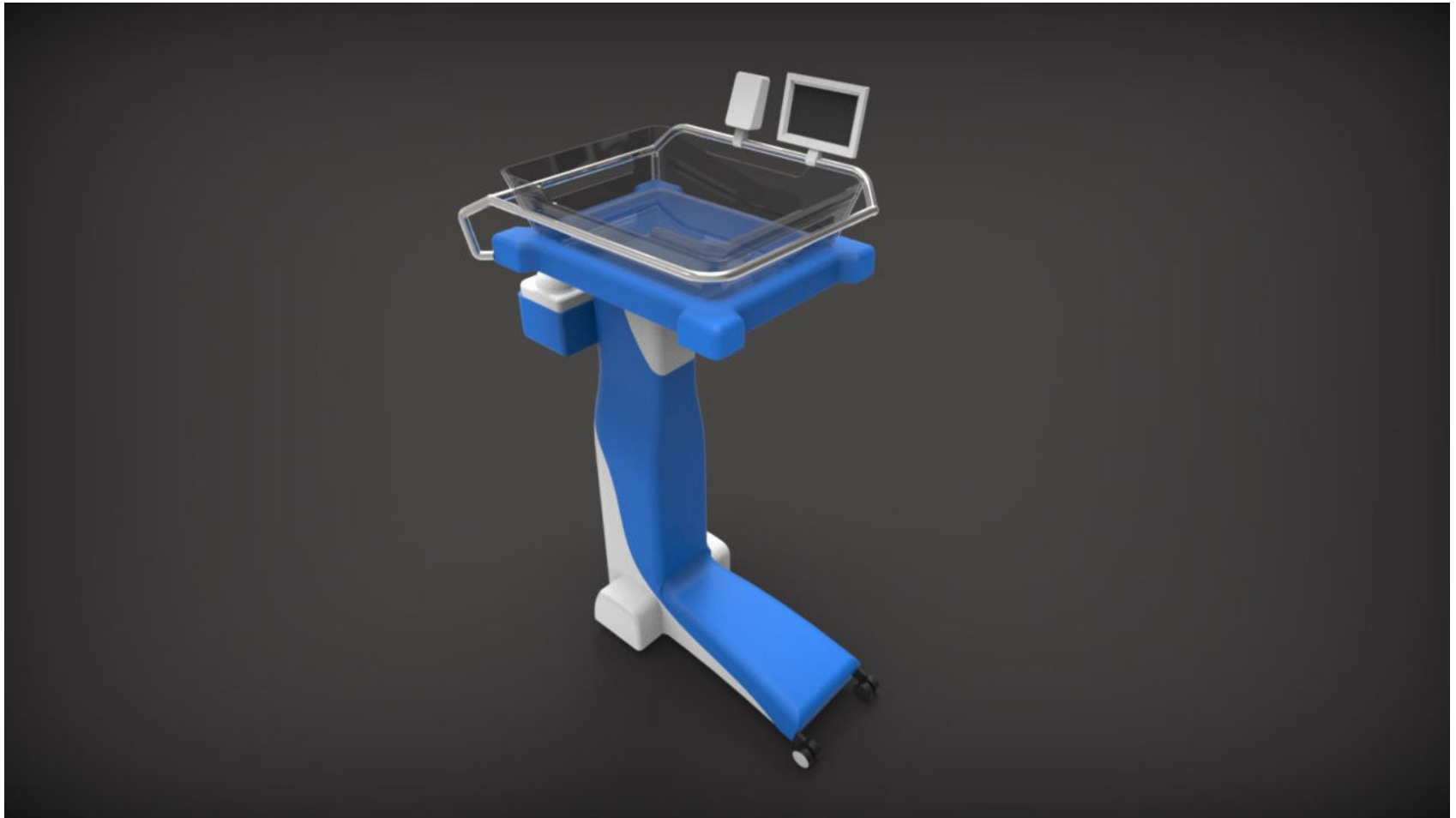

# Final Render

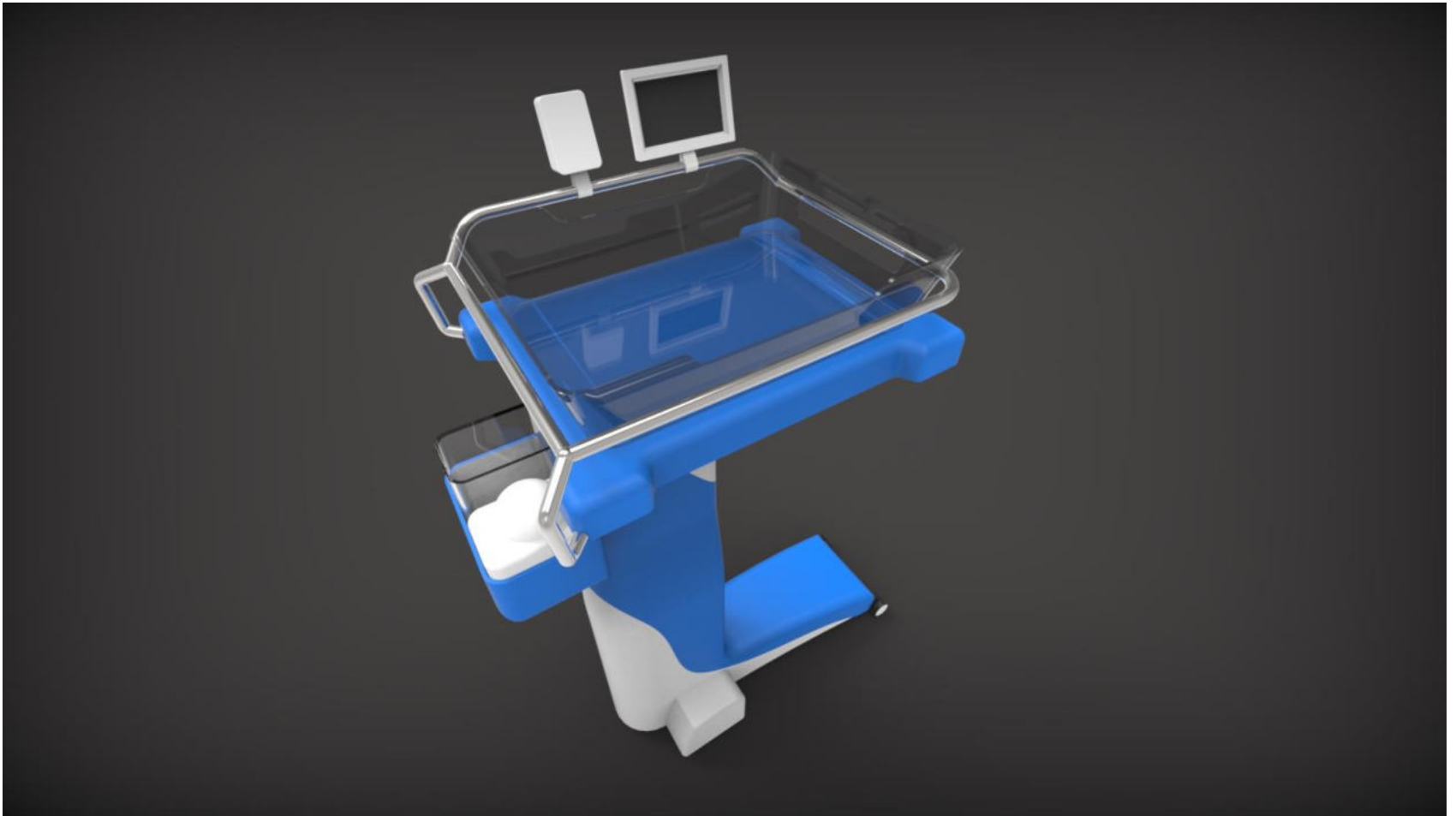

Thank You

