

# **Design intervention in Ambadi Calyx removal**

Industrial Design Project III- IDP603

**MDP 481**

**Ankur Rawal**

**156130002**

Guide: Prof. R Sandesh

Industrial Design Centre

Indian Institute of Technology, Bombay

2015-17



# Declaration

The content produced in this project report is an original piece of work and takes due acknowledgement of referred content wherever applicable. I understand that any violation to content infringement entitles the institute to take disciplinary action against me to which I shall be answerable to.

The thoughts expressed herein remain the responsibility of myself (undersigned) and have no bearing on or does not represent those of Industrial Design Centre, IIT Bombay

Ankur Rawal



# Approval Sheet

The project titled- 'Design Intervention in Ambadi Calyx removal' by Ankur Rawal (ID 2015-18, Roll Number 156130002) is approved for partial fulfilment of the requirements for the degree of Masters of Design in Industrial Design

Guide: \_\_\_\_\_

Chairperson: \_\_\_\_\_

Internal Examiner \_\_\_\_\_

External Examiner \_\_\_\_\_

# Abstract

Ambadi, globally known as Roselle (scientific name: Hibiscus Sabdarifa) is a nutritional herb with various health and economic benefits stemming from processing of its various parts.

Over the past few years, the importance of Indian Roselle has re-emerged as a nutritional and medicinal herb. Global demands have skyrocketed for its healthy Hibiscus tea. It is envisioned that Indian roselle reaches higher economic potential to match that of Malaysia, China and Africa. Current bottleneck lies in optimizing the separation process so that more produce can be made from the 10 day long annual cultivation season. Hence, this project aims at bringing in a design intervention for enhancing the production while exploring MSME and SHG style set ups to enterprise the crop and bring benefit to the farmer and associated channels at large.

The plant's morphology and vernacular nomenclature was observed at first along with gathering all available information about the dimensions of varieties under cultivation. Through the RuTAG team and from project guide's network in Vidharbha region, two enterprises were found out- one being an institute for village initiatives and one being an entrepreneur who has India's first Fssai licence for Ambadi Tea. The two economic models were thoroughly studied for their approach to labor, logistics and quality. Desk research about Roselle's development in Florida, Sudan, Kenya and Malaysia was done along with understanding basics of food post-processing. Two commercial retailers from ecommerce websites were also contacted to seek bottlenecks for the industry in general.

The task at hand was to reduce the drudgery in Calyx removal process of Ambadi and initial ideations including sketches and mockups were done much before the harvesting period, so as to take a primary feedback from stakeholders while doing an initial field visit. This helped us in having very involved conversations with the enterprise heads and the modifiable nature of the mockups helped us quickly iterate based on feedback.

Various cutting principles were sketched out, clustered and refined to form five ideas, each of whose mockups were taken to field for primary feedback. Sketching phase also included three unique workstation arrangement and material handling options.

The first field visit helped understand the status quo and gather stories about successes, failures and earnings over last few seasons. This helped us define parameters for developing the machine and its expected output. Selected two ideations in their refined avatar were fabricated in metal while keeping it adjustable for various options in height, blade edge dimensions, holding patterns, base etc.

The second was scheduled towards the end of the cultivation period. This visit helped us see the separation process in action, meet the villagers and see the hands right after a cultivation period. We also got to test the refined ideas and compare it to existing methodology of separation. Two parameters were used for evaluations- approximate energy expenditure and time taken. these were done using a heart rate monitor and a stopwatch app on the mobile phone. This time the cutting tools being used, ancilliary equipment, material handling, weighing and drying equipment, etc were documented. Samples of the fruit were also taken for testing later.

The ideations with their options were tested and further refinements arrived at in consultation with the stakeholders. These were brought back to the drawing table and the final concept was formed. Once detailed, it was fabricated and made to spec. Then tested by a user in various conditions with respect to ergonomics, namely seated on the floor, standing on a table, etc. container orientation and muscle duress was also estimated.

This academic project culminates at an interim stage in the overall scope of proposing a designed 'roselle ecosystem' with the introduction of a workstation tool for SHG style separation of the calyces. The same tool shall be further tested in the coming season and then scaled up into a machine.



# Acknowledgment

This project was conceptualized as a part of Rural technology Activation Group (RuTAG) project in collaboration with Centre for Science in Villages, Wardha (CSV). The project was initiated by Aarti Kava from Pune last year and her insightful report helped me a lot in the initial months of the project. My sincere thanks to Prof R Sandesh for encouraging me to take this project as my P3. The nature of the project and the socio-agronomics kept me attracted at the start of the project and as every 'super exciting' idea, this project too went through its stages of highs and lows for my personal productivity but Prof Sandesh kept uplifting me every now and then. The project would not have reached this stage had he not nudged me for being regular.

I am glad to have met amazing individuals like Mr. Sanjay Deshpande in Nagpur and the team at CSV headed by Dr. Soham Pandya who have showcased the immense potential than an agrarian society like ours can benefit from (and also for having hosted us during our brief and ill-planned visits). Thanks to Mohd Ahtesham who is Sandesh sir's research assistant for helping me at prototyping during a minor workshop injury and also in the validation visit in December to Wardha. I also wish to acknowledge the insights shared by kawl Thazami from Zoei's online shop.

I thank Prof Bapat for showcasing his earlier agri-design based projects and the creative possibilities of system level interventions. The workshop staff, especially Kailash, Samarth, Nawale and Kenny sir for providing guidance and specific tools for the prototyping days.

My dearest classmates and seniors who have shown immense support, guidance and got their hands dirty in ideating along with me: Antik, Raju, Ram and Shyam. My partner in crime (for most parts), Arjun for his constant motivation and knocks on my hostel room door for when they were important.

- Ankur Rawal

# Content

*Declaration*

*Approval Sheet*

*Abstract*

*Acknowledgment*

<b><i>Roselle- a background</i></b>	<b><i>...1</i></b>
One crop- many names	...1
What is a Calyx	..2
Key sellable commodity	..2
Plant structure	..3
Harvesting cycle	..3
Benefits of Ambadi	..4
Fruit Dimensions	..5
Insights from other sellers	..6
<b><i>Task at hand</i></b>	<b><i>..8</i></b>
<b><i>Initial project brief</i></b>	<b><i>..9</i></b>
<b><i>Initial Ideations</i></b>	<b><i>..10</i></b>
Idea-1-peeling	..12
Idea-2-scoring	..14
Idea-3-slicing	..18
Idea-4-standalone scoring	..24
Idea-5-pipe and bore	..26

# Content

<b><i>Field visit-1</i></b>	<b><i>..31</i></b>
Mr. Sanjay Deshpande	..32
CSV- Dr. Soham Pandya	..33
Status Quo	..35
Key Observations	..36
Feedback on ideations	..38
<b><i>Concept development</i></b>	<b><i>..40</i></b>
Tested concepts	..42
<b><i>Field Visit-2</i></b>	<b><i>..44</i></b>
Visit Summary	..46
<b><i>Connecting the dots</i></b>	<b><i>..48</i></b>
Tools	..48
Material handling	..49
Drying and Weighing	..49
Current mode of separation	..51
Heart rate data	..52
Time baed data	..53
<b><i>Concept feedback</i></b>	<b><i>..54</i></b>
<b><i>Final Concept</i></b>	<b><i>..56</i></b>
Manufacturing drawing	..57
<b><i>Ergonomic Audit</i></b>	<b><i>..58</i></b>
<b><i>Additional Work</i></b>	<b><i>..64</i></b>
<b><i>References</i></b>	<b><i>..66</i></b>

# Roselle- a background

Roselle, (scientific name: *Hibiscus Sabdarifa*) is a short-day plant usually grown in tropical and subtropical areas. In the United States, it has been grown commercially in Florida, California, Louisiana and Kentucky. Many home gardeners have figured out how to grow *Hibiscus* successfully as a warm weather annual.

The calyces of *H. sabdariffa* are prolific in many modern commercial blends of cold and hot drinks due to its natural tanginess and pleasing taste, as well as having decorative, culinary and medicinal uses.

## Scientific Classification:

Kingdom: Plantae

Phylum Angiosperms

Class: Eudicots

Series: Rosids

Order: Malvales

Family: Malvaceae

Genus: *Hibiscus*

Species: *H.sabdariffa*



### ***One fruit many names***

The Roselle is known as the rosella or rosella fruit in Australia, Germany and United States (the three main consumers of dried roselle calyces)

Other popular names of the fruit in different Indian languages are:

'Ambadi' in Marathi

'Belchanda' among Nepalese,

Tengamora among Assamese,

'Mwitha' among Bodo tribals in Assam, 'Mesta tenga' among Rabha tribe and 'Hanserong' among Karbi tribals in Assam,

'Chukor' in Bengali,

'Anthuk' or 'Sougri' in Manipur,

'Gongura' in Telugu, also called as 'Andhra Matha' or 'Andhra Sakhambari Varaprasadam' in Telugu,

'Lal Chatni' or 'Kutrum' in Mithila

'Mathipuli' in Kerala

'Chin baung' in Burma, and 'Chin-pown' in Myanmar.



## ***What is a Calyx***

Calyx: (a collective term for sepals of a flower); Epicalyx (a collective term for structures found on, below, or close to the true calyx, also called false calyx). Some varieties show pronounced epicalyx structures, such as found in variety Arab (plural calyces).

Roselle calyces can be processed into sweet pickle. This is usually produced as a by-product of juice production. However, quality sweet pickle may require a special production process.

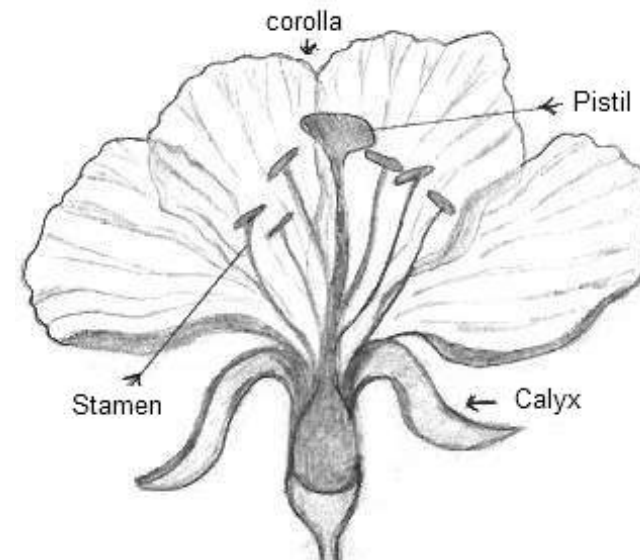

Structure of a flower

Image Source: Wikipedia commons

## ***Key sellable commodity- dried roselle calyces***

Dried roselle calyces can be obtained in two ways. One way is to harvest the fruits fresh, decore them, and then dry the calyces; the other is to leave the fruits to dry on the plants to some extent, harvest the dried fruits, dry them further if necessary, and then separate the calyces from the capsules

The former is an easier method of separation as the juicy calyces are easier to separate manually



Dried Calyces

Image Source: author

## ***Plant structure***

Roselle is an erect, bushy herbaceous subshrub that tops out at anywhere from four to seven feet tall and almost as wide.

Stems are typically round and smooth. Alternate, deeply lobed green leaves are usually three to five inches long with reddish veins and toothed margins. When flowers first open, they are light yellow with a rose or maroon eye. As they mature during their one-day life span, they gradually darken to a dusty rose colour. Flowers hug the stem, as they are borne in the leaf axils on short petioles. However, the 3- to 5-inch flowers are visually significant as they bloom up the length of the stem during the late summer and early fall months when the days grow shorter.

At the base of each flower is a fleshy, bright red structure called a calyx (sepal). It is this part that is harvested and used to make juices, sauces, jellies, wines, pies, and other tasty edibles. The calyces (or calyxes) are separated from the seeds for use in recipes. If left on the plant, the calyces eventually turn brown and split open to reveal the seeds.

One important thing to note is that it cannot be successively grown throughout the year. Seeds are sown during the rainy season and fruits are harvested during November in India.

## ***Harvesting and cultivation***

Ambadi grows in parallel to cotton in the Kharif season (July-November)

When grown as an intercrop with cotton, it renders additional advantages (as claimed by farmers in Wardha):

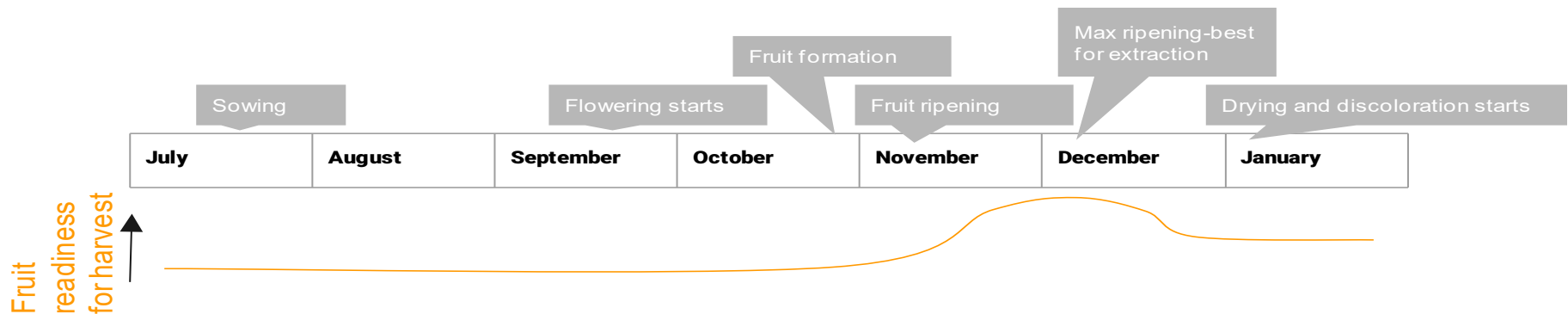

# All round benefits of Ambadi

## ***Acts as a natural pesticide:***

Insects, rodents, monkeys and stray cattle do not ambush Ambadi crops. This protects the cotton plantations for the farmers

## ***Roselle seeds are a rich source of protein and oil***

Many farmers and cultivators around the world plant roselle for domestic consumption and use the excess seeds as dietary supplements for their pets. Some also use it to extract oil for household consumption

## ***Abundance of Cheap labor- cotton pickers***

Freelancing cotton picker communities are naturally found in cotton growing areas. Cotton picking being a day-time activity, helps set up small households to take up Ambadi separation in their evening times. Many households follow this routine to enhance their livelihood in the months of november and December. Children and young females of the households who do not engage in cotton picking carry on this work during the daytime at their leisure for the fortnight of Ambadi separation.

## ***UN FAO on Roselle cultivation***

Roselle is an ideal crop for developing countries if market demand is favorable. It is drought tolerant, relatively easy to grow, not suitable for mechanized harvest, labor intensive to process, and can be grown as part of multi-cropping system. In addition to fodder and fiber, it is used for other purposes as well.

In China the seeds are used for their oil and the plant is used for medicinal properties, and in West Africa the leaves and powdered seeds are a local foodstuff. In East Africa, Sudan and Jamaica it is also referred to as 'Sorel' the name also used in the pharmaceutical and food flavoring trade in Europe.

Like many specialty botanical products, market information is not readily available for roselle. Prices and production are not tracked like a conventional agricultural commodity and there are few, if any, published market reports

New producers can rarely expect to sell anything but whole Calyx, as once processed it almost impossible to clean.

Thailand is the only country that has been able to add value locally by cutting and sifting the calyces into tea bag size

Reference: [http://www.fao.org/fileadmin/user\\_upload/inpho/docs/Post\\_Harvest\\_Compodium\\_-\\_Hibiscus.pdf](http://www.fao.org/fileadmin/user_upload/inpho/docs/Post_Harvest_Compodium_-_Hibiscus.pdf)

## Insights from other sellers in India

In order to find out bottlenecks faced by other entrepreneurs in the trade, a few sellers from indiamart were contacted. one of them responded to the queries on facebook



### Key insight

Entrepreneurs prefer contract farmers for harvesting and cultivation who provide whole fruit to them. Separation, drying and post processing is done inhouse.

Regional names such as Anthur and Gongura are used for branding and pack sizes are mostly suited for occasional tea making. (50g dried calyces makes about 12-15 cups of tea)

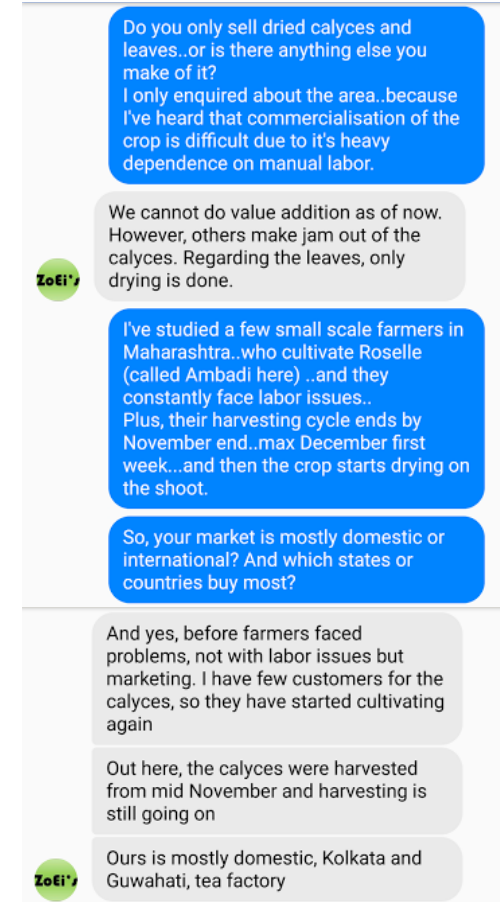
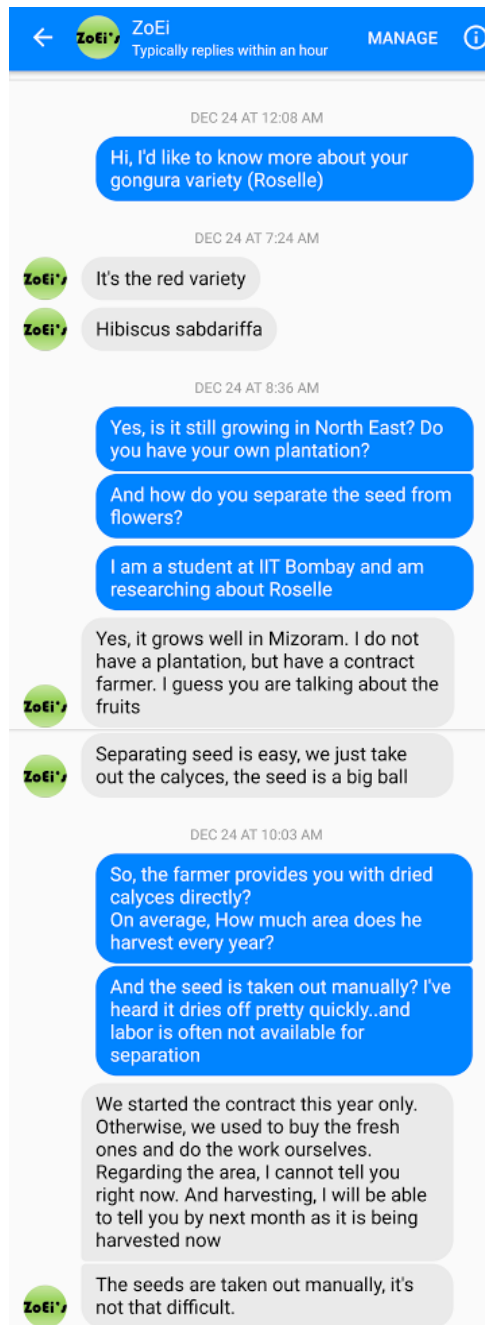

< Conversation with Kawl Thazami, who is a botanist by profession and also sells Dried roselle leaves and Calyces on her online shop under the name of ZoEi

Online shop: <http://www.giskaa.com/dried-roselle-fruits-anthur-rah-rep-50-g>

# Fruit dimensions

ID	Fruit			Seed pod			dia for cutting tool
	Diameter max	Height (from base- w/o stem)	calyx thickness (max)	Diameter (max)	Height		
1	32.03	29.65	2.79	21.82	23.56		16.44
2	30.72	29.59	2.53	22.12	21.4		15.39
3	30.76	29.27	2.78	22.07	22.36		15.53
4	32.01	28.13	2.7	22.14	21.88		16.16
5	32.94	26.89	2.39	22.85	22.36		15.64
6	31.36	23.42	2.81	21.98	21.25		16.49
7	33.47	30.43	2.85	20.79	22.63		15.54
8	30.84	30.88	3.22	22.13	23.87		15.54
9	32.02	33.66	1.92	24.05	23.14		15.41
10	29.28	33.68	2.37	22.1	22.09		17.17
11	30.86	29.84	2.89	22.08	21.31		16.09
12	28.64	26.11	1.8	21.35	21.7		15.07
13	29.81	25.87	2.68	20.62	23.38		13.41
14	28.42	22.5	2.35	19.56	19.73		14.41
15	32.32	28.91	2.45	21.3	22.5		15.21
<b>MEAN</b>	<b>31.0</b>	<b>28.6</b>	<b>2.6</b>	<b>21.8</b>	<b>22.2</b>		<b>15.6</b>
minimum	28.42	22.5	1.8	19.56	19.73		13.41
Max	33.47	33.68	3.22	24.05	23.87		17.17

All dimensions in mm

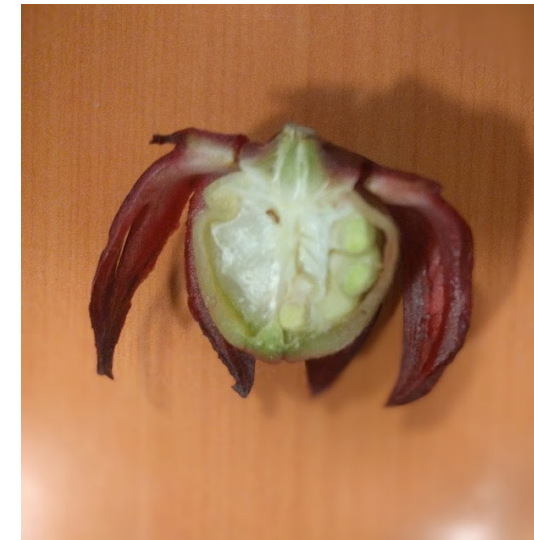

Cross section view showing the seed pod enclosed within the red calyxes

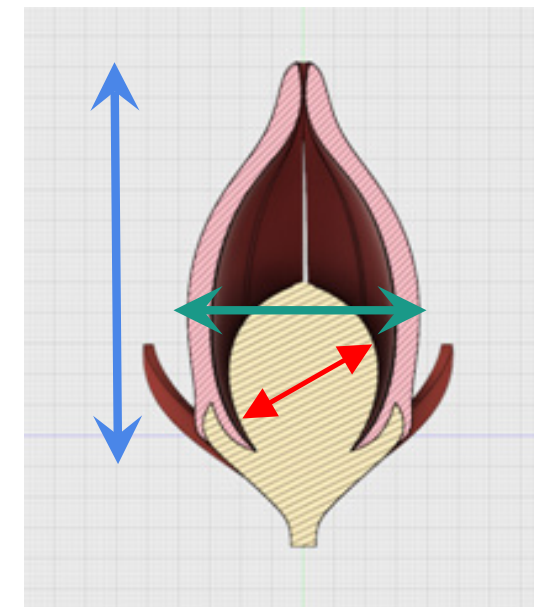

**Ambadi products**



Frozen Ambadi fruit



Ambadi Tea



Ambadi pickle (left) and Bread spread (right)



Ambadi fibre products

Image source- Author

# Task at hand

Calyx separation process is done manually currently, due to several factors:

Organic shape and dimensioning

Removal process depends heavily on the orientation- unlike cherry or olive depitting

Fruit dries within 3-4 days of harvest and separation can only happen within this time frame

High climate dependence of crop allows for a small annual window of 2 weeks for cultivation

Manual process lacks standardisation and hence productivity cannot be estimated well

Which in turn hampers dependency and reliability in industrializing the production even in an SME model

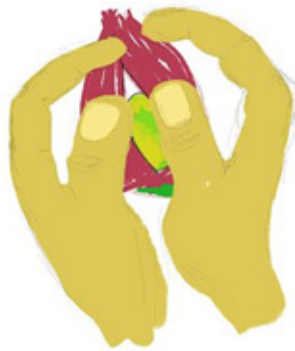

# Initial project brief

To design a machine for enhancing the production performance of Ambadi calyx removal process.

The machine as opposed to a hand tool, would cut multiple ambadi fruits at once.

The device should ensure effective separation of Calyces and seed pods in a convenient fashion.

Full recovery of calyces required as opposed to shredding. The machines Should require less skill to operate -and be suitable to work with self help group models.

Manual mechanical interventions are preferred over complete/semi automation using electric motors.

# Initial ideations

*Since the project started in August 2017 and the crop season was not to start before October, I started desk research and ideation based on Aarti's report and online resources*

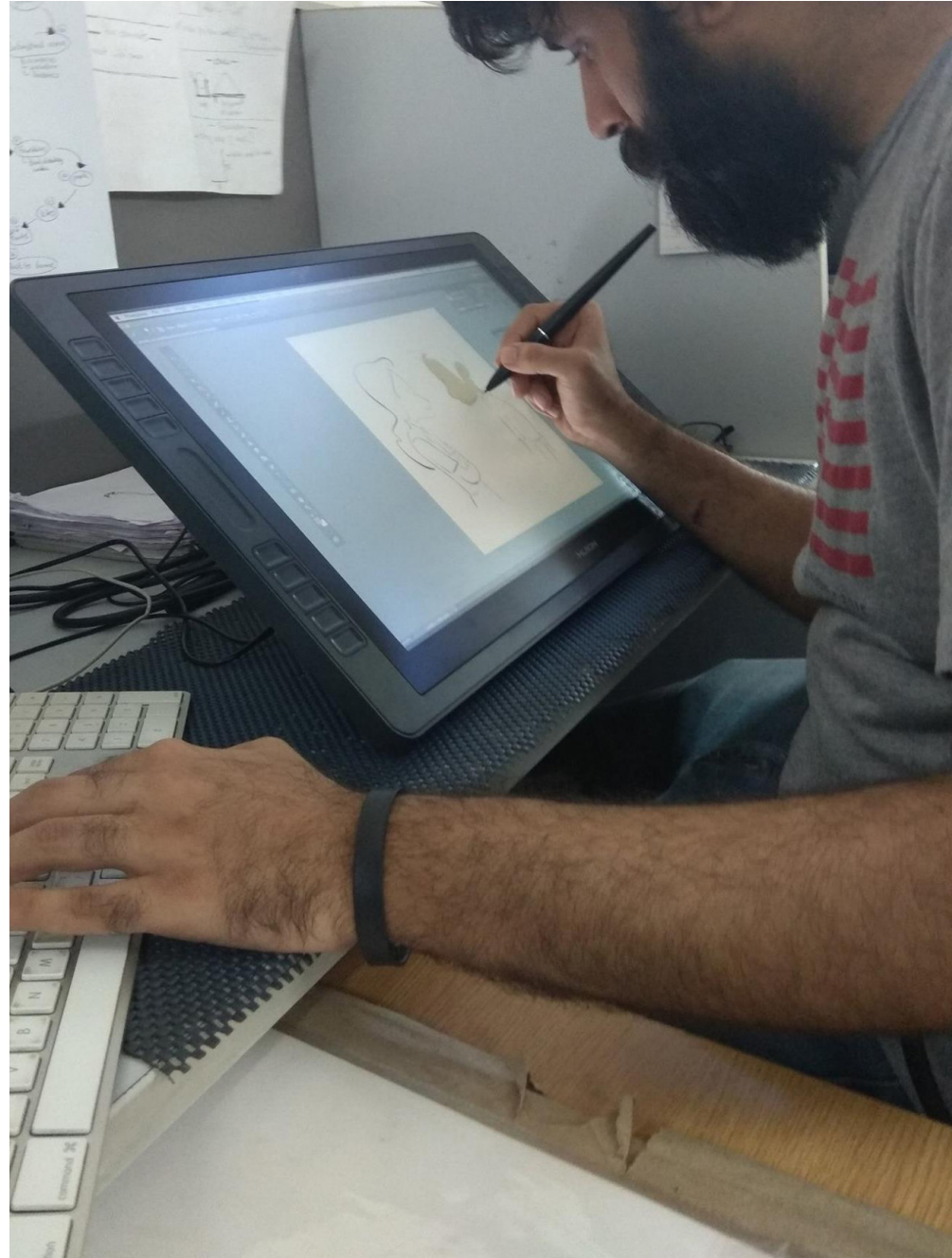

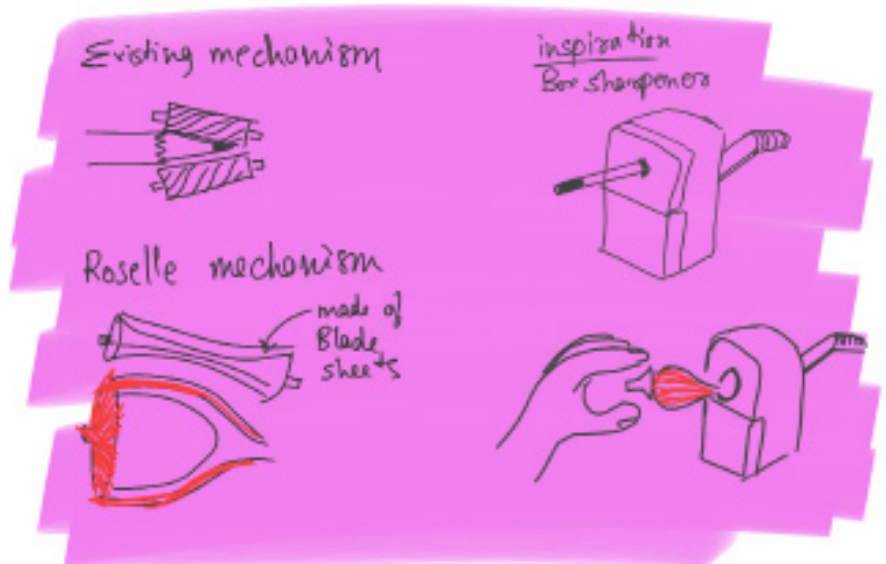
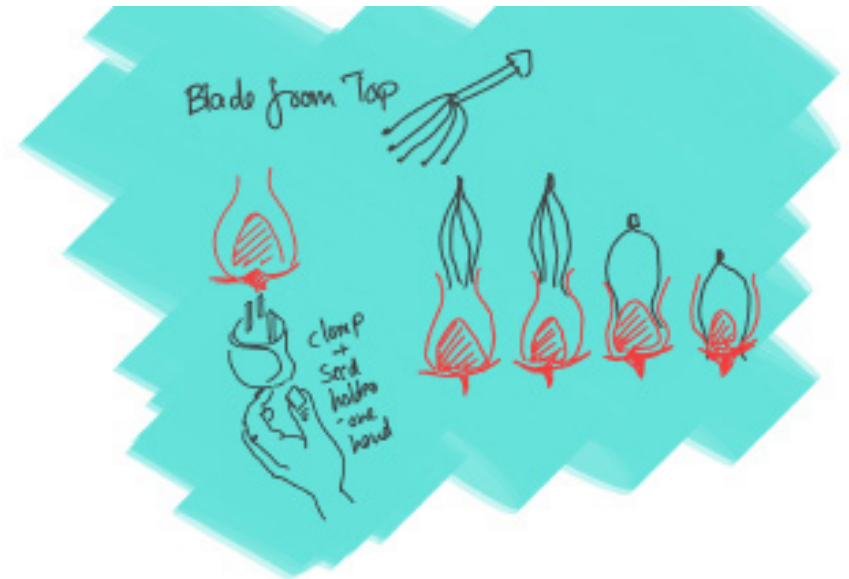
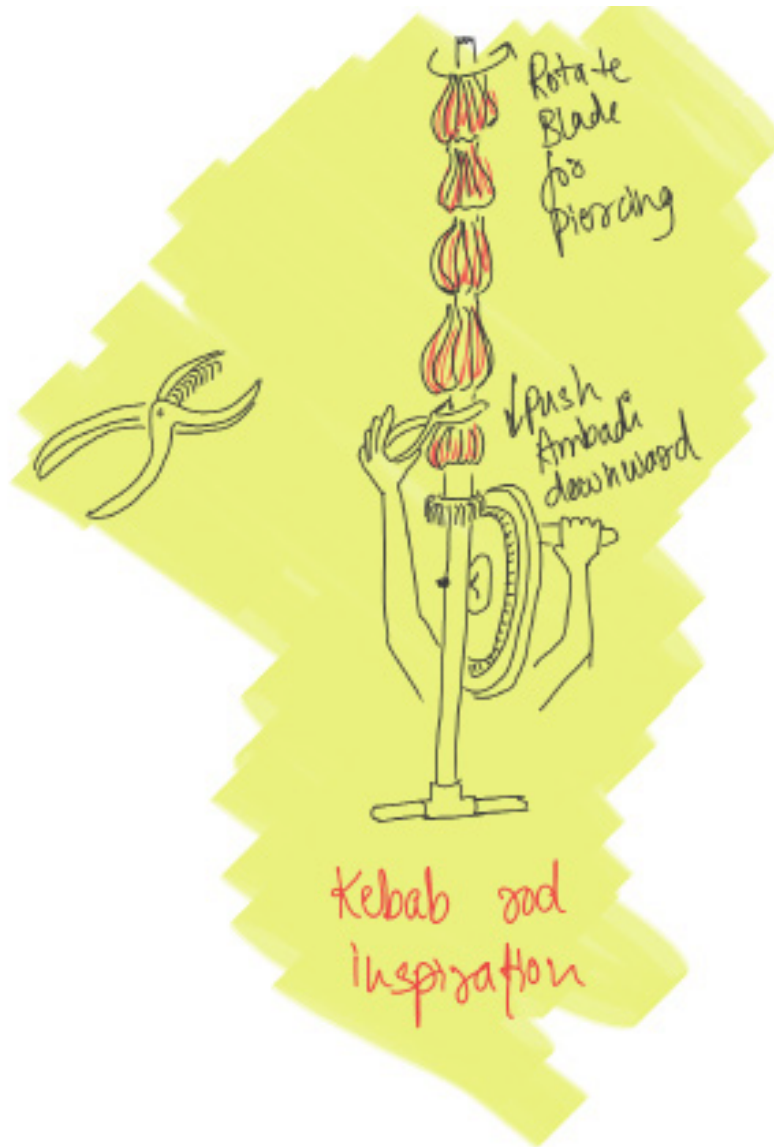

# Idea 1- peeling

Idea is to create an incision at the bottom of the fruit, in the area between the calyx and seed pod.

This would practically peel off the calyxes from the base

The seed pod would have been mounted on a three nail jig, which can later be ejected using a lever

a, b and c along with suffixes correspond to the different positions of levers shown in adjoining page

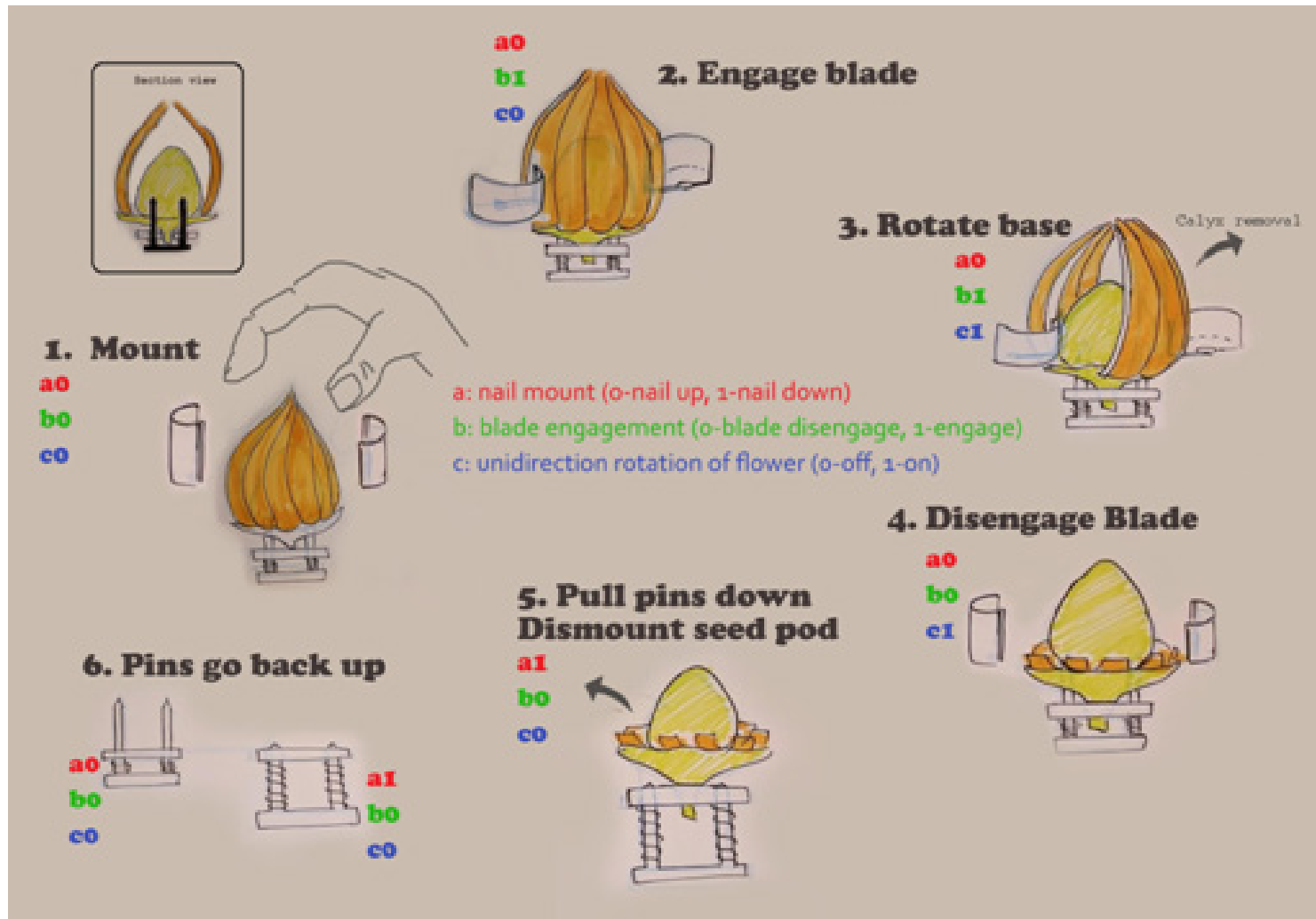

## Mockups

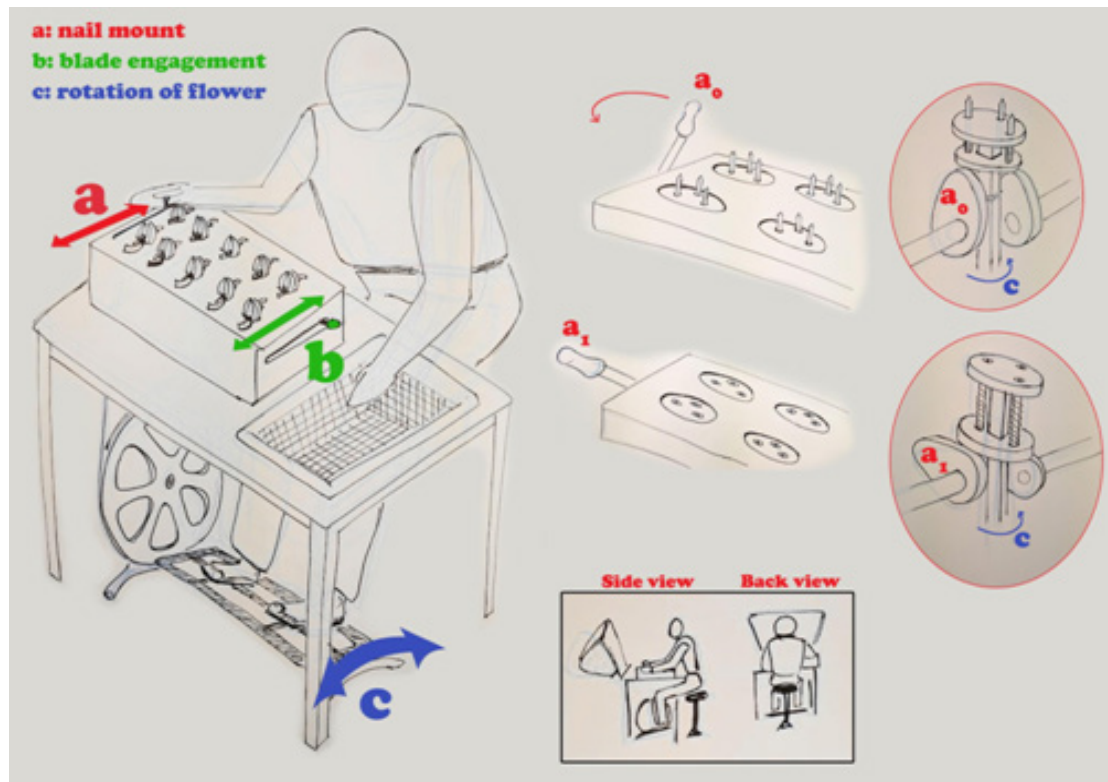

**One man machine design , with a hand lever and foot based actuation for rotation**

**(Inset)- movement of lever (a) to raise or lower the nail mounts from base**

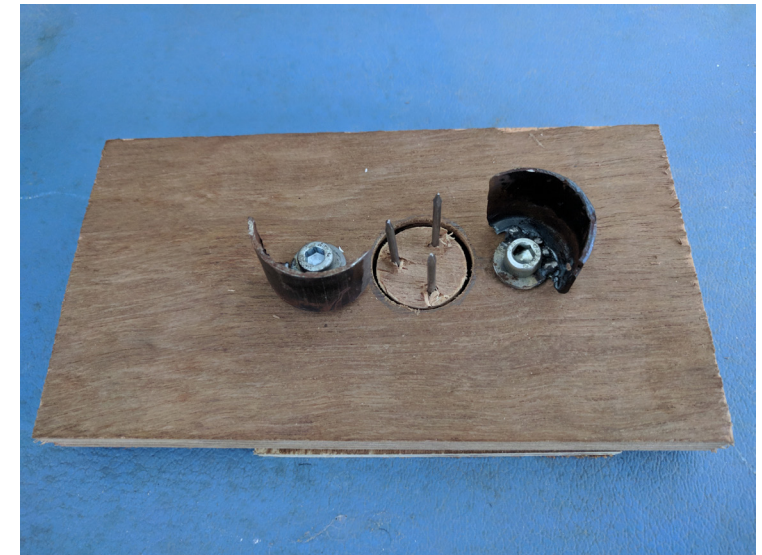

Nail mount with disengaged blades



Dummy Ambadi fruit mounted on nails and engaged blades. Once the nails are rotated, the Calyx is expected to fall off leaving the seed pods behind

# Idea 2- scoring

Idea is to score the ambadi calyces from the periphery and increase the depth of cut until it separates itself from the base (which includes the seed pod)

This is an evolution of the earlier ideation wherein the blade profile is changed and mounting and blade engagement is re-looked at

Blade movement is made eccentric so that engaging, rotation and disengaging can be done with least moving parts

The nail mount is no more rotating, only the circular blades rotate

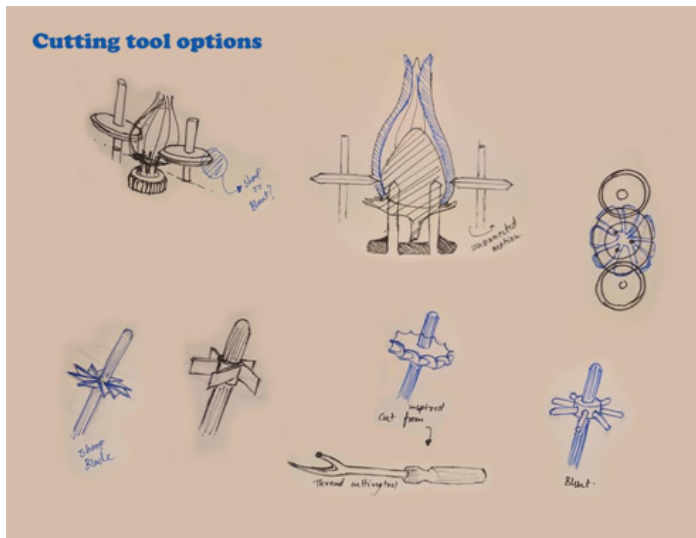

TOP View of blade movements

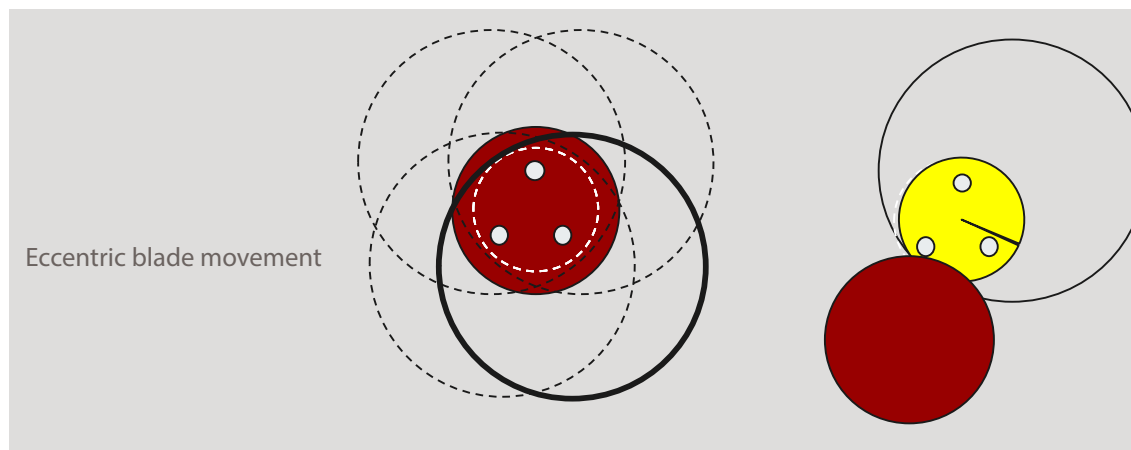
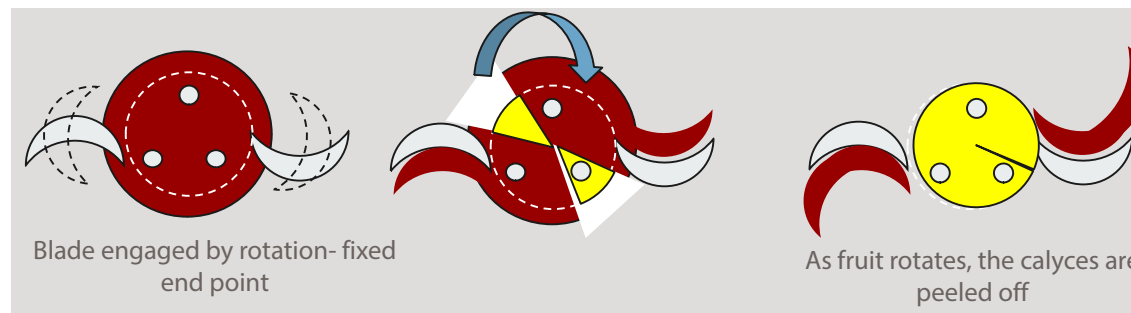
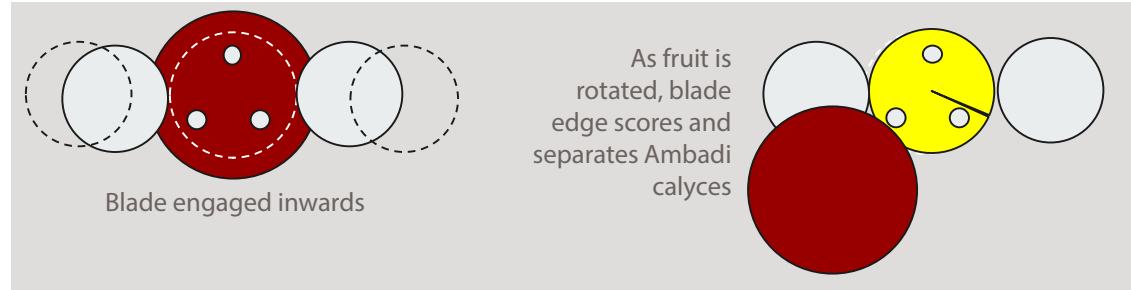

**Mockups**

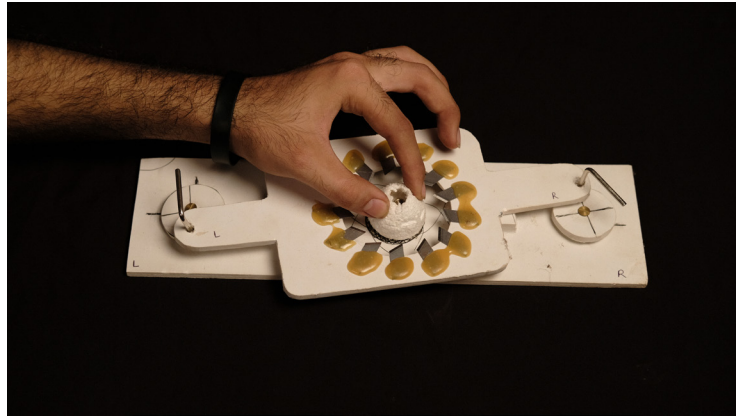

< Mounting  
Ambadi on a static  
centre

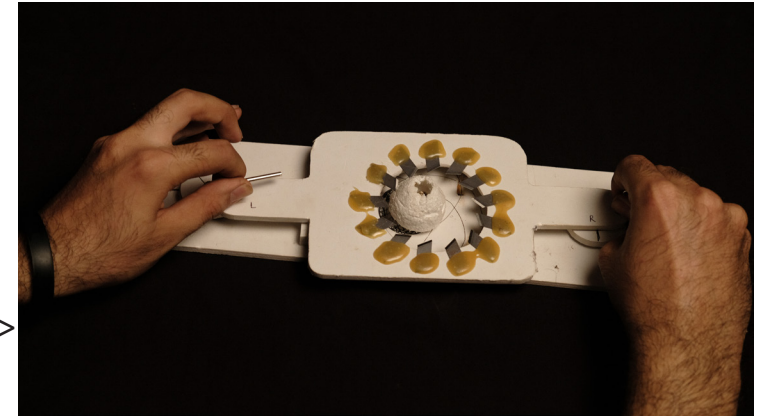

> Rotating blade

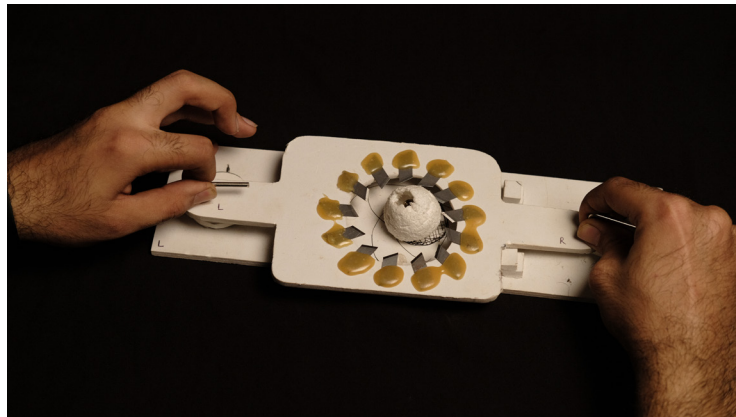

< Further blade  
rotation (complete  
a 360 degree)

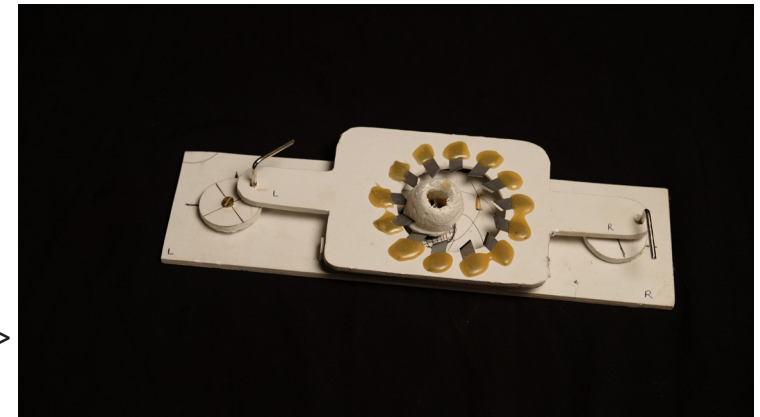

> calyx (top) gets  
separated from  
seed pod

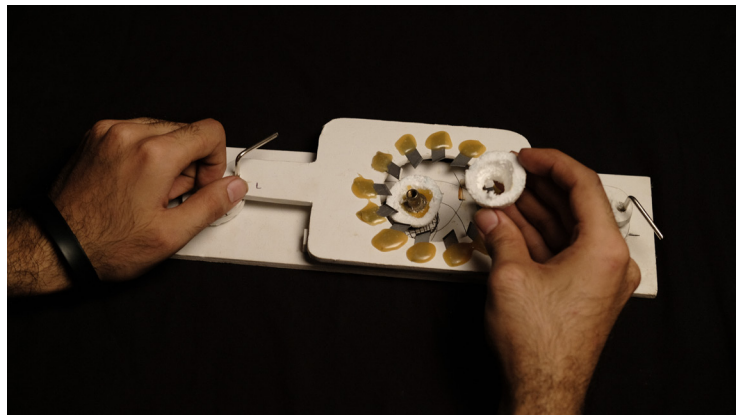

< Separated calyx

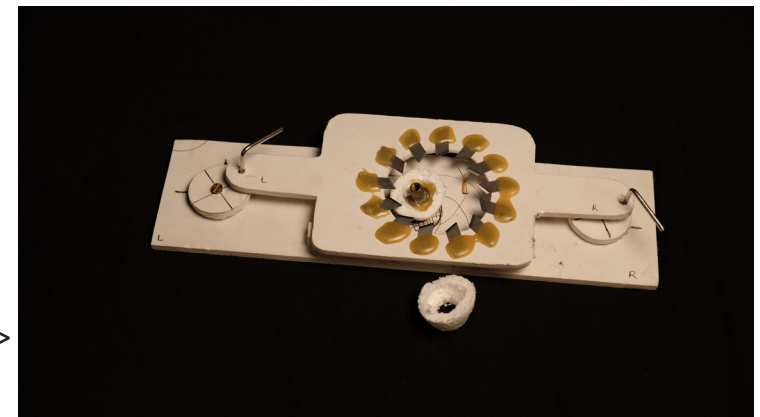

> Seed pod remains  
on central mount

# Idea 2- scoring- system

Arrangement of possible machine, proposed number of people and associated activity

Machine involves two people- one who engages the blade (named II in diagram) and the other who removes separated seeds and mounts fresh Ambadi fruits onto the tray (named IV in the diagram)

(I and III) are stacks of trays. I being filled with fresh uncut fruits, while III being ones with seed pods alone after separation has occurred

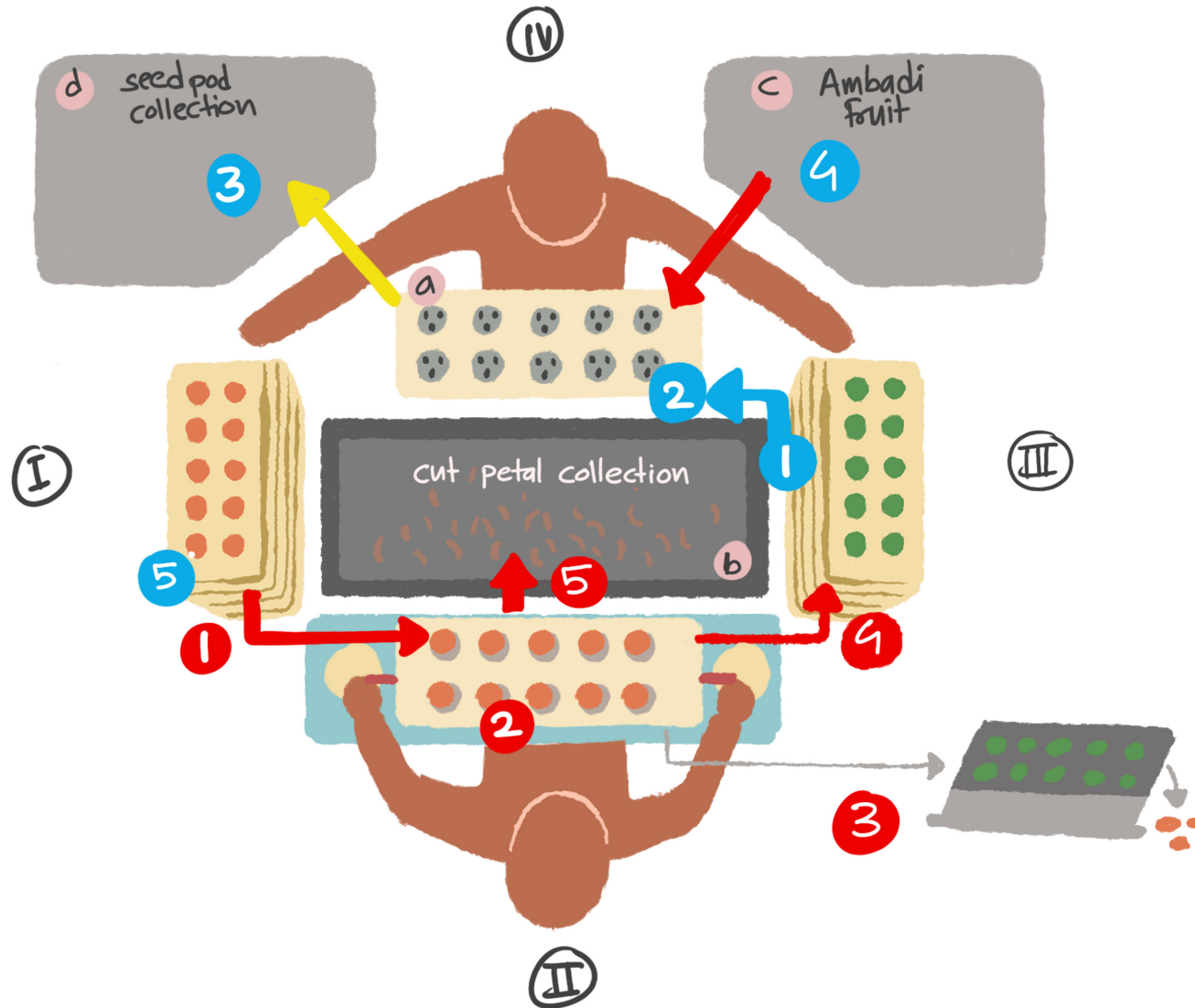

1

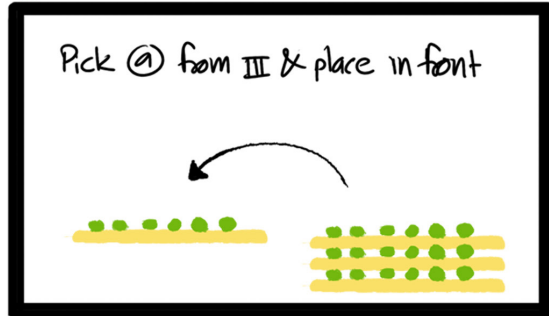

2

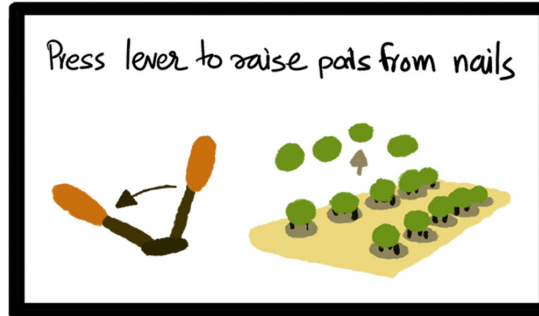

3



4

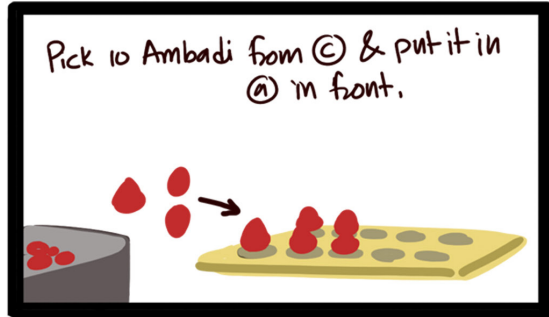

5

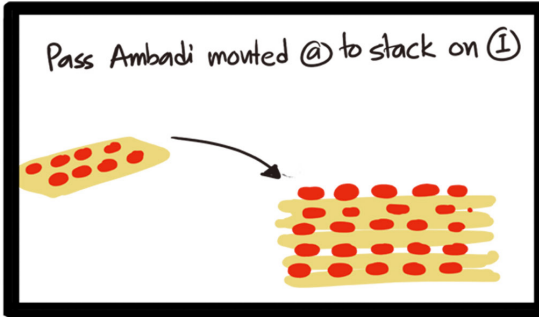

1

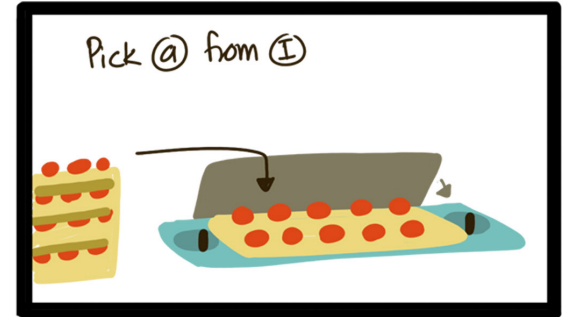

2,3,4

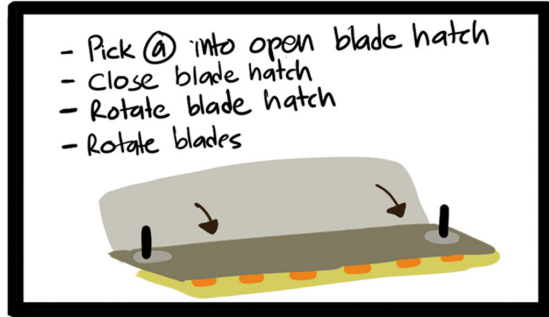

5

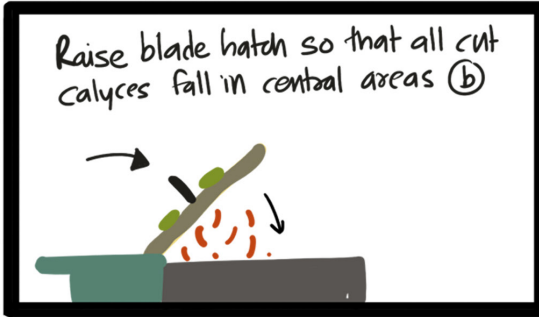

6

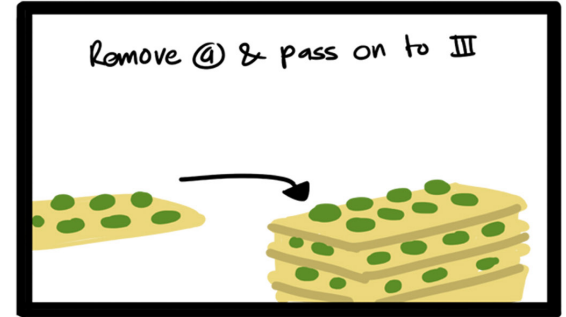

# Idea 3- slicing

Hold Ambadi at the area around seed pod close to stem

Cut using a blade right next to the mounting fixture, in order to result in 3 parts of ambadi as shown on the right

The bottom portion is waste, while top two portions are put through a segregation process

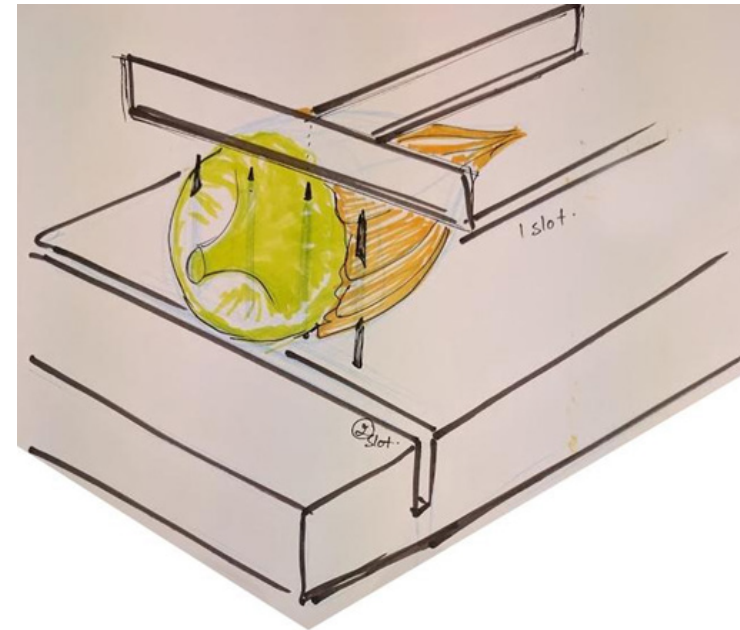

Cut pieces of Ambadi expected from

1) Single blade



2) T-shaped blade

## Mockups

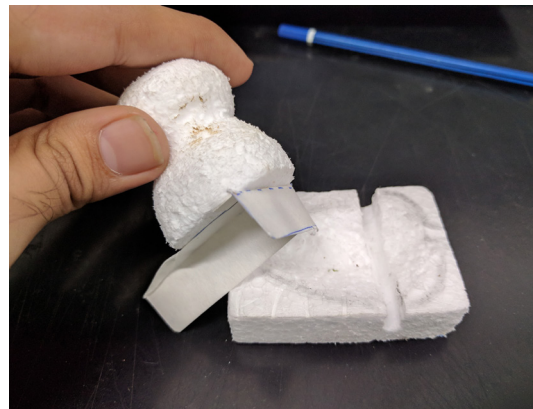

Thermocol mockup with carved blade holder for fruit



Metal proto with nails as base holder for Ambadi

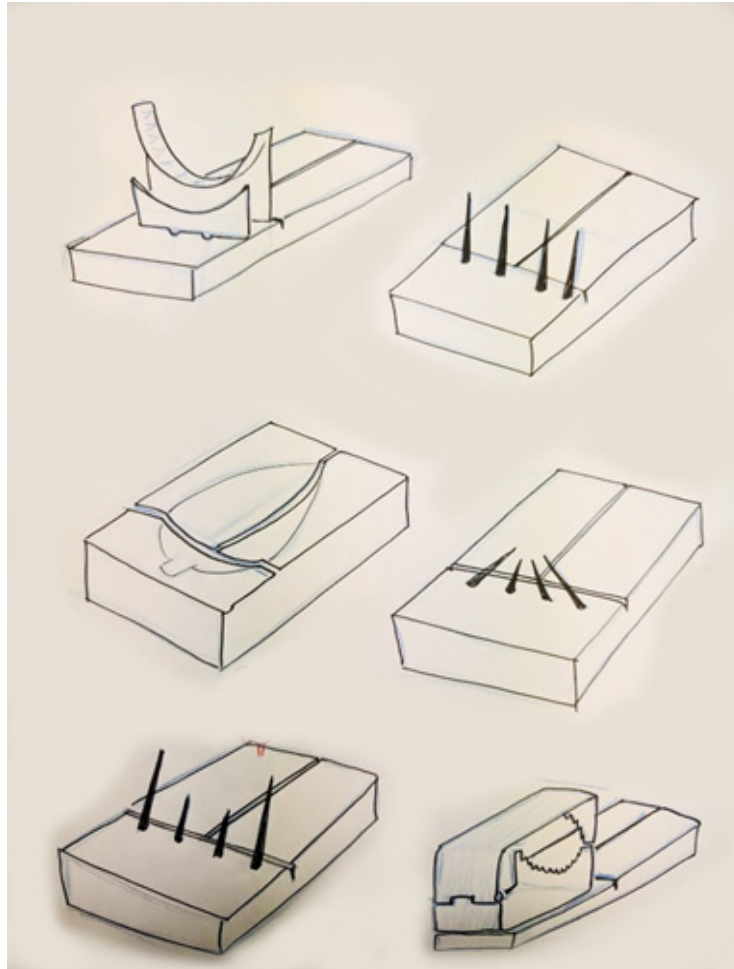

1) Fixture options

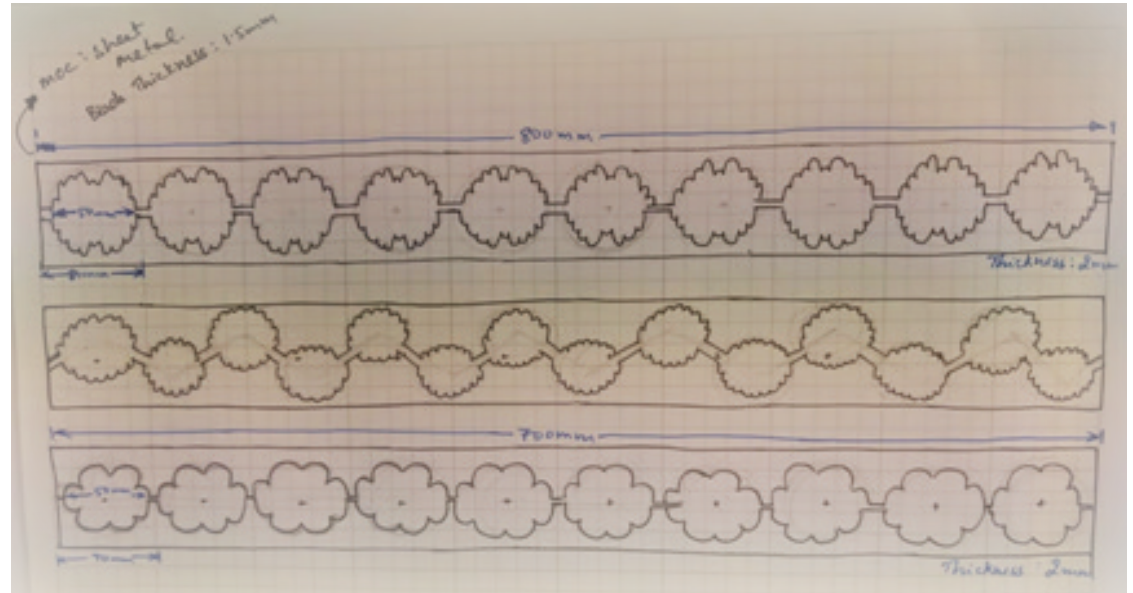

2) Fixture profiles for 10 units

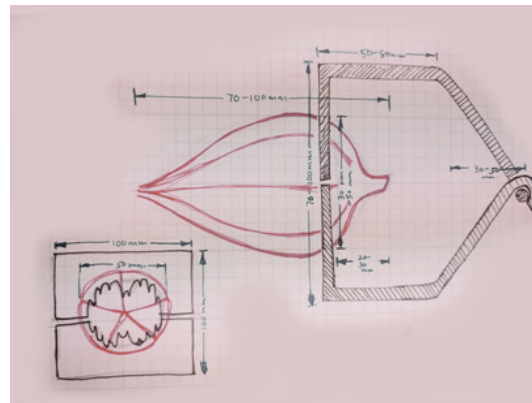

3) Approx dimensions

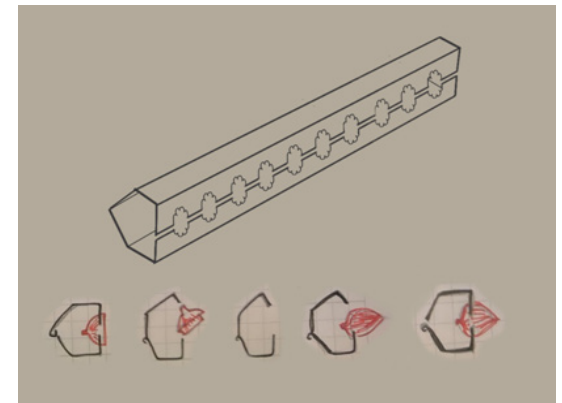

4) Profile of fixture with steps of opening, mounting and closing

# Idea 3-slicing

*Fixture Mockups- development*



Mockups with dummy fruit- place for 10 in number

PVC pipe used to check for frugal clamp design

Flat jig which can be table mounted

Welded jig in Steel for feedback from stakeholder

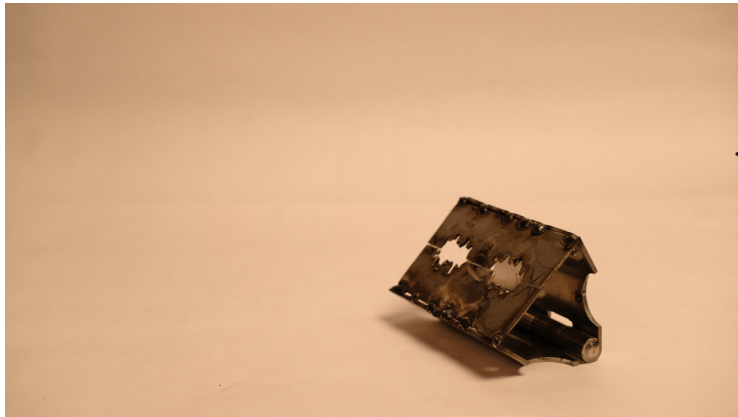

< Unopened jig

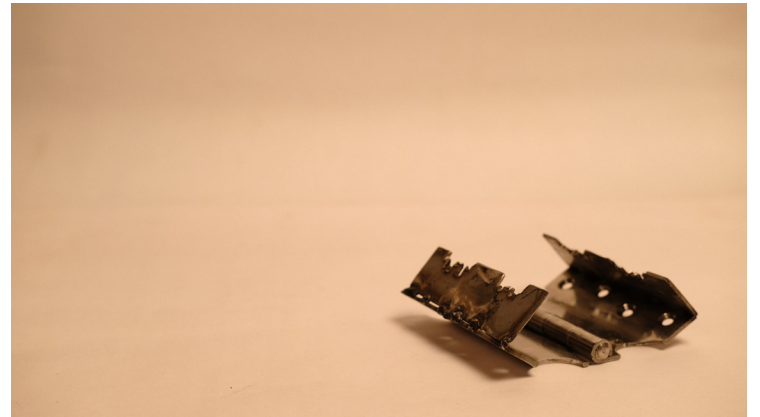

open jig >

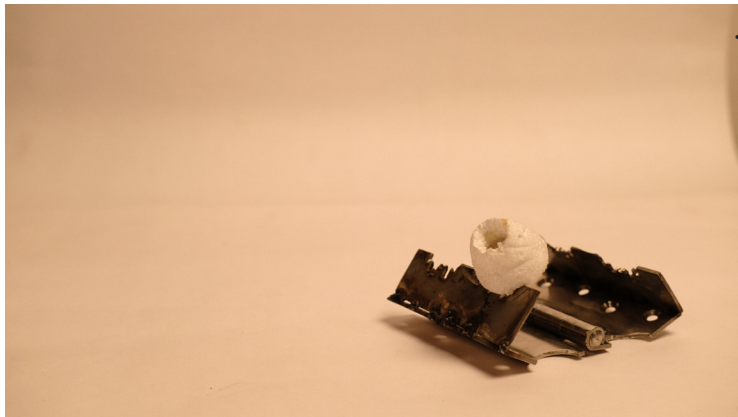

< Ambadi placed

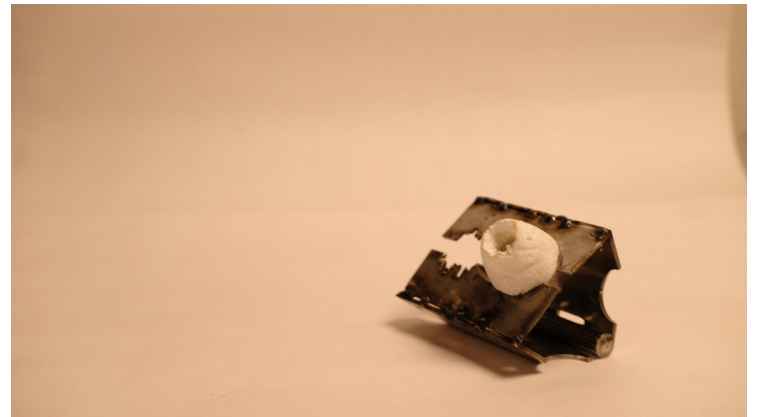

Jig closed >

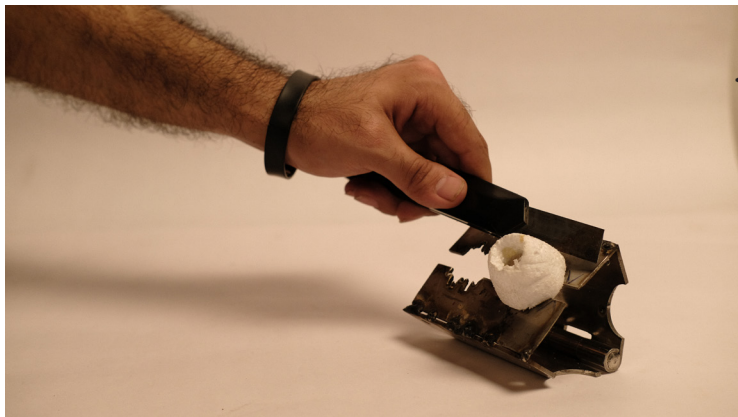

< Blade cuts through Ambadi

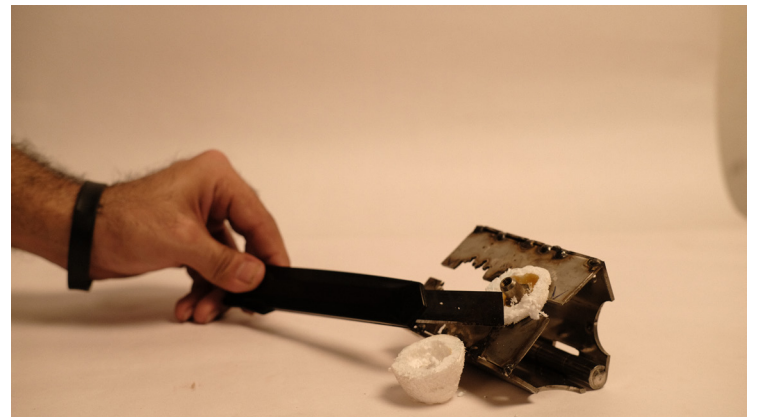

Seed pod remains on mount, Calyces separated >

# Idea 3- slicing- system

Top view of machine ideation

Machine involves a two floored conveyor, both converging at one end while diverging at the other.

The cutting T blade is mounted on one end with the 'Ambadi cutter' who in one stroke cuts and separates the Calyces which are mounted on a tray and passed on by the 'Ambadi placer' on the other side of the conveyor

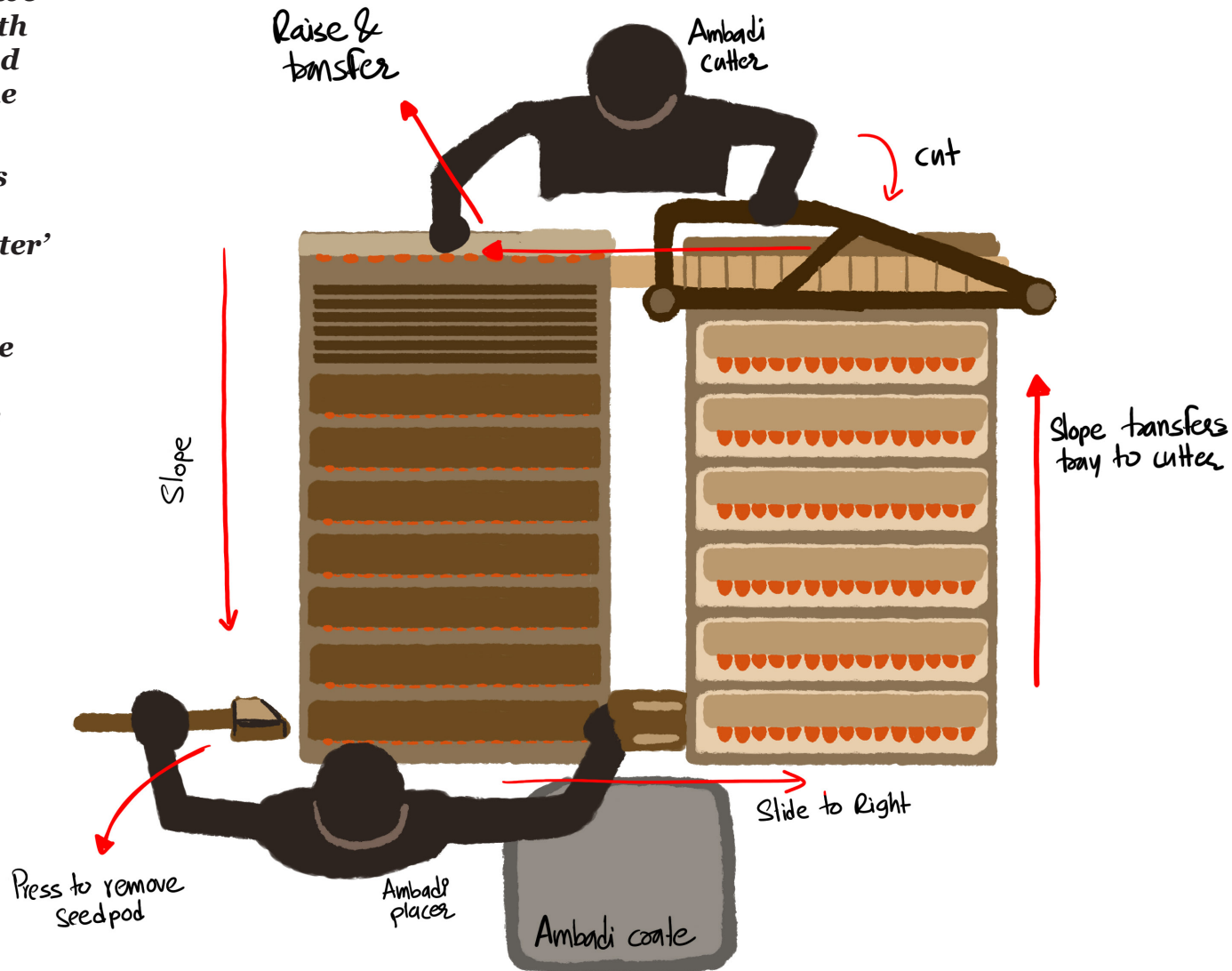

*Side view of machine ideation*

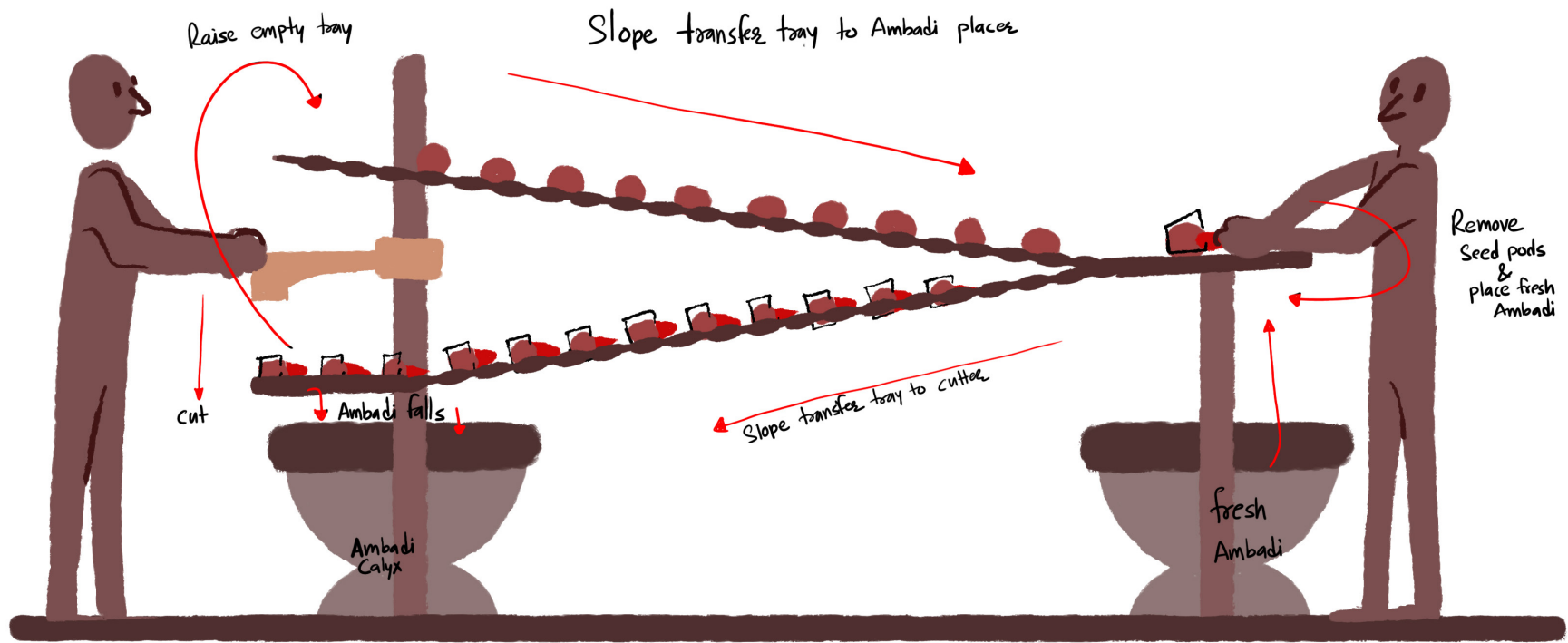

# Idea 4-standalone scoring

*Inspired from idea 1 and 2, with their scoring aspect utilized for separating calyces of 1 Ambadi at a time*



< Fruit rested in hand, while crank rotates a mounted blade

Fruit mounted on central blade mount attached to crank, Two outer blades score and cut through calyces as crank is rotated >

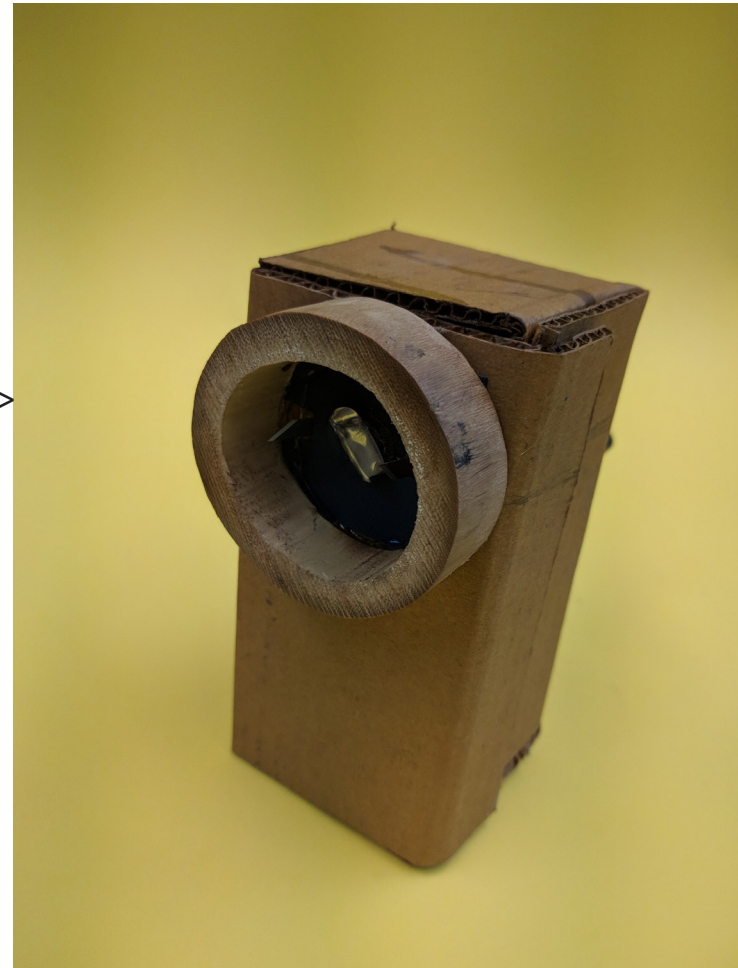

***Cutting action:***

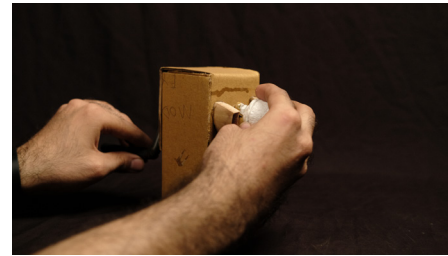
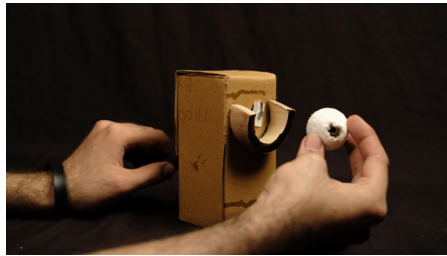

Fruit held with hand, while crank cuts a circular incision on calyxes which eventually fall off



Fruit mounted by hand once onto central nail mounts, then retracted for incision by outer blades until calyxes fall off. (Fruit is not held by hand)

# Idea 5-Pipe and bore

*A circular pipe with a cutting sleeve. The idea is that the sharp edge of the pipe would cut through the calyces and the inner pipe would help eject the seed pod*

Ideation sketch

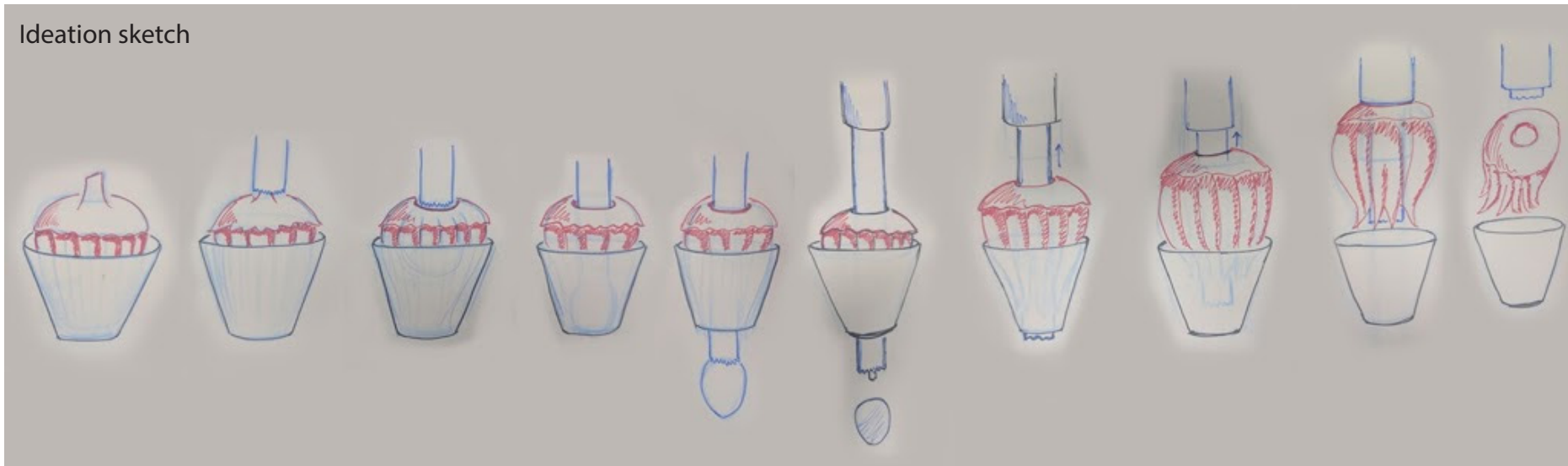

*base mount mockup  
in sheet metal and  
grating sheet*



**Mockups**



stand



Rod

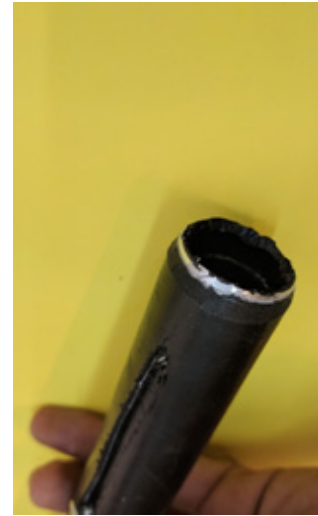

Cutting edge

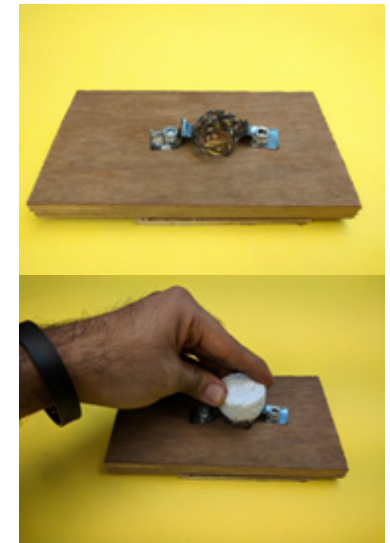

Base made for mounting  
Ambadi fruit

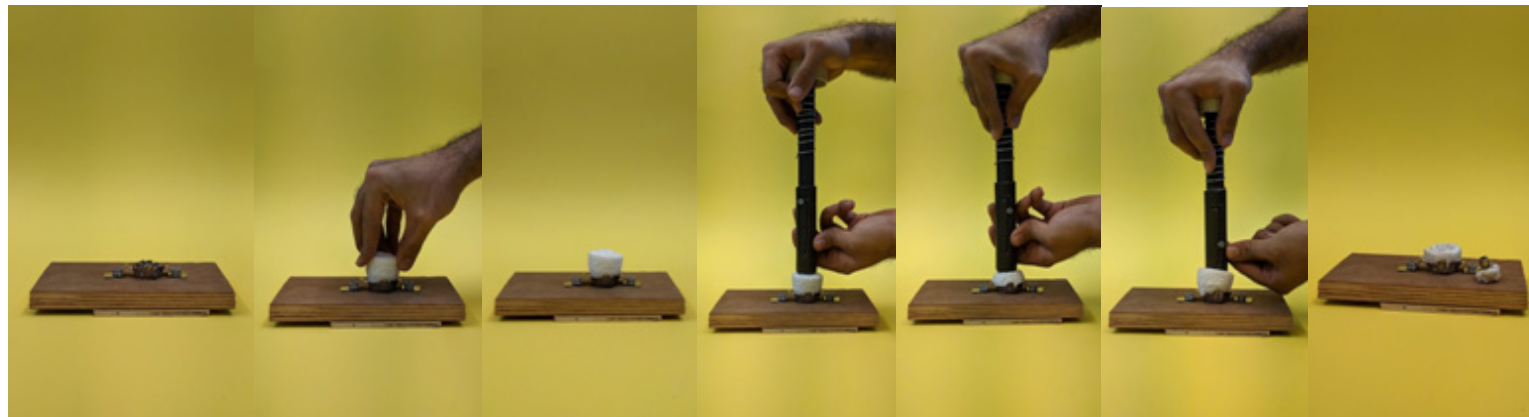

Cutting action



Dummy fruit with a hard  
seed pod

# Idea 5- Pipe and bore- System

*Two man Turret style design*

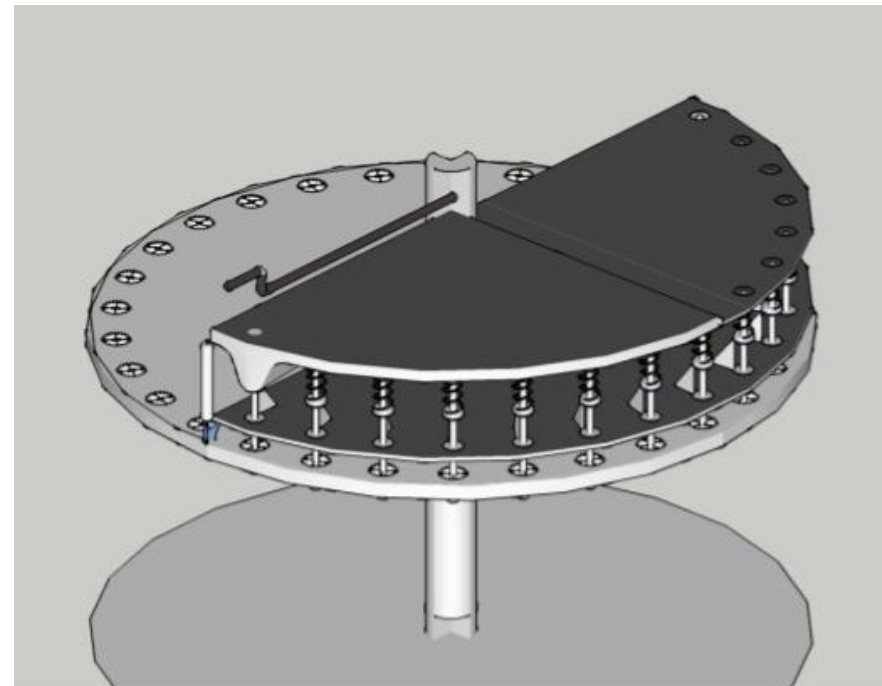
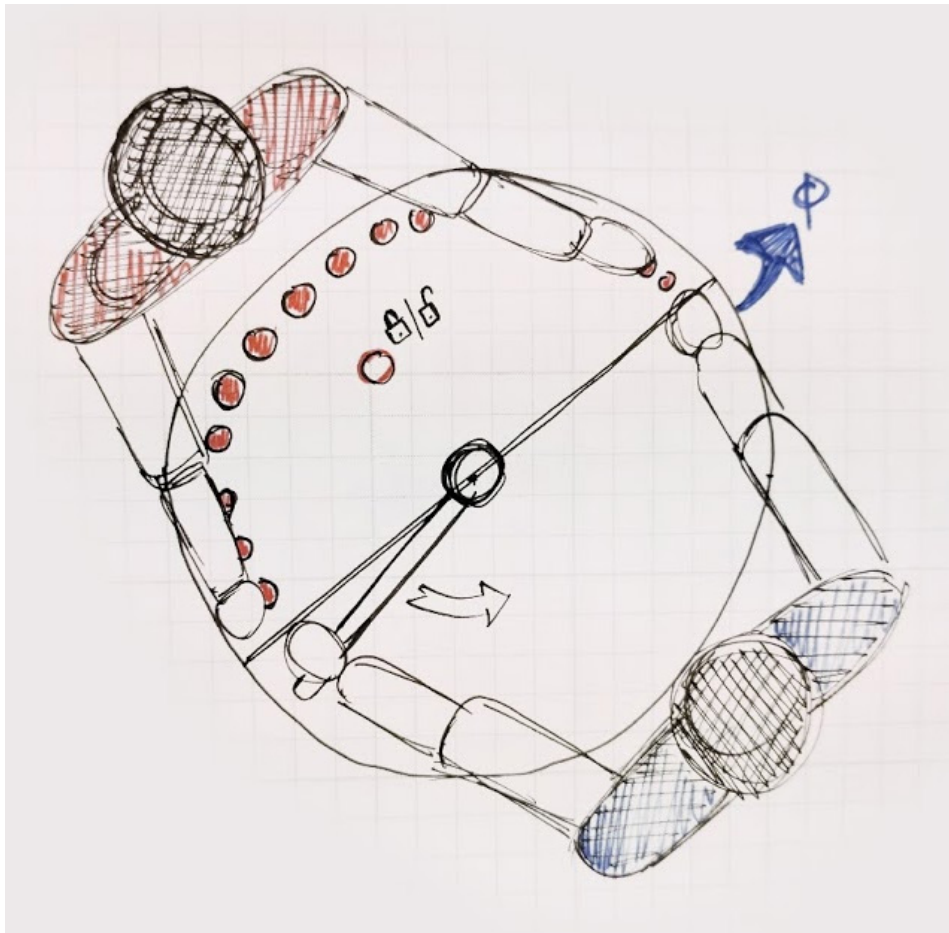

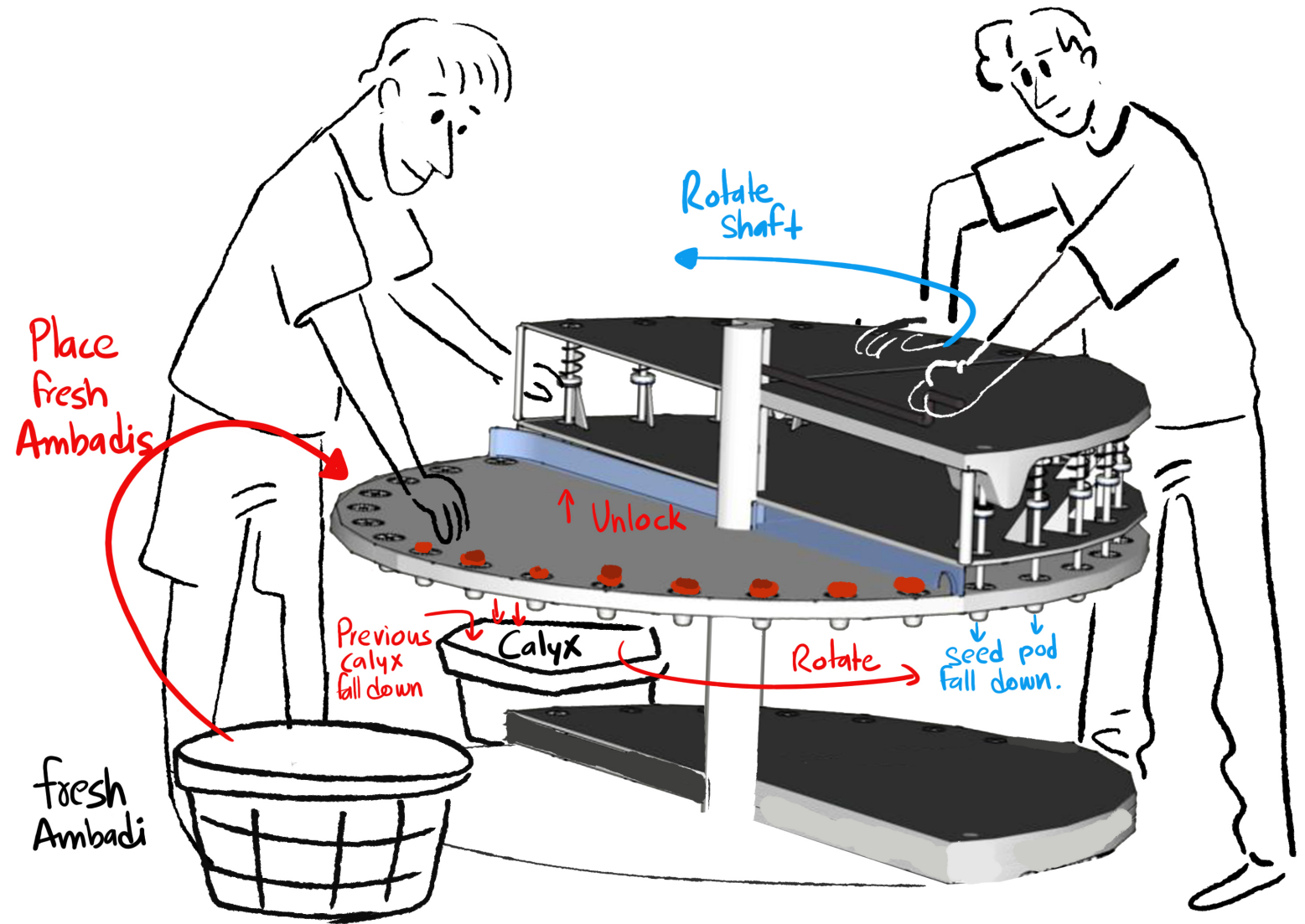



# Field visit

*Along with meeting the stakeholders and observations, the initial ideation prototypes were also reacted upon*

*Date: 25-27th October*

*location: Wardha and Nagpur*

## *key people met:*

*Mr. Sanjay Deshpande, Agronomic Entrepreneur*, holds first fssai licence for Ambadi tea in India, has faced issues in commercially utilizing Ambadi crop for tea making

*Dr. Soham Pandya and team, Centre for Science in Villages, Wardha (CSV)*, have developed various sample agrarian economies around Honeybeekeeping, paper recycling, Sanitation, Housing as well as Ambadi harvesting.

# Nagpur- Mr. Deshpande

*Having cultivated an Australian variety of Roselle, we were able to see the fruit in person*



Roselle ready for harvest



Mr. Deshpande giving feedback on ideation mockups



Salaried farmer in the background

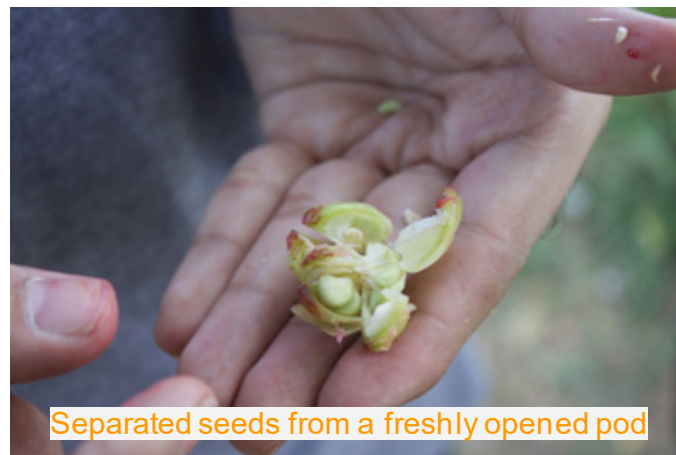

Separated seeds from a freshly opened pod

According to Mr. Deshpande, it takes 1Kg seeds to plant 1 acre of Ambadi plantation when cultivated standalone and about 1/2 acre when planted intercropped with cotton.

These 1Kg seeds in 1 acre plantation can give about 100Kg of fresh Ambadi fruit, which contains approx 45-50kg fresh calyces (when separated).

These would lead to about 7-10Kgs of dried calyces (80-90% of fresh calyces are water, which is lost upon drying)

***Upon visiting the farm we observed how a makeshift tool was used to bore out the seed pod from the fruit***

Mr. Deshpande had encouraged contract farmers to plant Ambadi in their lands and provided the tool, skill and seeds for 300 acres of total plantation.

Most farm owners found it difficult to separate the calyces in time and only about 30% was recovered from the planned output.

Mr. Deshpande had sought to purchase separated, dried calyces at 300Rs/Kg but still the farmers complained of the amount being insufficient for the labour involved.

So, he foresees a mechanical separator which requires minimum labor and readily separates calyces from fruits like a conveyor line



# CSV- Wardha

*In the month of October, CSV's plantation of Ambadi had barely reached the flowering phase*



Premature Ambadi



Farm under cultivation this year-2 Acres



Some shoots still haven't crossed flower shredding phase



Dr. Pandya briefing us about initiatives taken for Ambadi in CSV

# Status Quo

*Current ecosystem in place at CSV wardha*



- 1- Cultivation and harvest at farm
- 2- Removal of Shoot upon preparation and transport to village
- 3- Villagers receive shoots of Ambadi from truck
- 4- Shoots divided amongst villagers and taken home for separation
- 5- Manual separation of Ambadi calyces while seed pods kept o shoot
- 6- Separated calyces taken to collection centre by villager
- 7- Calyces received
- 8- Villager paid
- 9- Calyces weighed
- 10- Put for drying for 7-10days
- 11- Dried calyces packedfor selling

# Key Observations

## *About the fruit:*

Starts drying immediately as you cut it from shoot

Within 3-4 days becomes dry and calyces stick harder to the seed pod-making it futile for separation

If kept too long after the maximum ripening, it starts to lose its color and later the whole plant starts drying as it gets colder

In a day, about 8-10Kgs Fresh Ambadi fruit can be separated by hand by one person. This is the evening occupation for many families there

## *About the Entrepreneur model:*

Cotton farmers in catchment encouraged and trained to intercrop Ambadi with cotton

Entrepreneur also cultivates in own facility

Seeds and Pipe tool (for separation) provided by entrepreneur

Farmer cultivates, cuts, separates and dries ambadi calyces

Entrepreneur buys back dried Calyces as per weight from farmers, processes into tea

Processing and blending done by entrepreneur who then sells the tea under his own brand

Vertically integrated Quality Checking ensured by entrepreneur

## *About the Institute model:*

Institute owns the farmland and cultivates Ambadi

Cotton picking labourers from nearby village engaged in cutting and separation

Institute buys back freshly separated Calyces (not dried) from labourers on weight basis

Dried Ambadi calyces sold as white labelled to nearby entrepreneurs on weight basis

Entrepreneurs mostly engaged in Sharbet making activity

Institute also makes Jam, bread spread, achar on their own and sells on their own

Quality of dried calyces ensured by Institute, final product Quality Checking ensured by enterprise

## Economics at play

Both (the Entrepreneur and the Institute) find payment for labour on weight basis more suitable as opposed to number of fruit basis or time

Approx 10Kg fresh Ambadi fruit can be processed by a labour in a working day

Entrepreneur currently gets full time labour @Rs150/day who separates 20Kg fresh Ambadi full fruit and pays additional Rs160/day for about 20Kg of cut fruits

When he buys dried Ambadi calyces from farmers, he pays them Rs 250/Kg

Institute gets part-time labourer families engaged in cotton picking and calculates productivity on per Kg of freshly separated calyces @Rs 30/Kg. Cost for cutting is borne by the village labourer (if cultivation is large) or institute (if cultivation is small)

1Kg Ambadi fruit roughly has 450-500grams fresh calyces which when dried result in about 50grams of dried calyces- which has a retail value of about Rs 350/Kg

Starting point of enterprise is dried calyces. Institute can afford a slow drying period, since a lot of land is available, while entrepreneur needs to invest in land for sun drying and wants to look for quick drying options

ledger maintained at karla village, CSV Wardha

On average one person currently separates 5-6Kgs of fresh fruit daily based on availability of stock to separate

Females of the house are seen to be involved in the account keeping. While their In-laws and kids also do the separation activity in case need be

CSV pays 15Rs/Kg of separated calyces and keeps the shoots with seed pods with themselves (underreported when compared to verbal communication)

# Feedback received on ideations:

*Obtained through mr Deshoande and discussion with prof Sandesh after looking at the fruit and its nature in operson*

## ***Peeling-1***

Rejected- since the seed pods are harder than anticipated and mounting them on nail mounts is very cumbersome and hence removal also made difficult

## ***Scoring-2***

Mount to be worked on, as in Ideation 1.  
Wastage of potent calyx and epicalyx at bottom to be avoided  
Seems more complicated

## ***Slicing-3***

Mounting above epicalyx layer wasnt acceptable  
Slicing through the hard seed pod and later recovering calyces from seed+calyx mixture not desired

## ***Standalone scoring- 4***

Scoring acceptable , but retrieving of calyces needs to be worked on

## ***Pipe and bore-5***

Most favored and workable on the face of it.  
taken further for development into concepts

***Post Jury discussions with Prof Sandesh***



***Outcome:: Development of pipe and bore concept further with :***

***Different diameter cutting pipes***

***Carved blade edges on readily available pipe diameters***

***Exploring possibility of using available blade parts and edges for the tool***

***Making the tool locally serviceable and consumables to be available atleast at any district level.***

***Material of construction to be metal and workstation ergonomics to be further studied.***

***Record and compare time taken in separation activity***

# Concept Development

*Making of different blade edges for further testing upon next visit in harvest season*



***16mm dia, 4 teeth blade edge***



***16mm dia, 5 teetch blade edge***

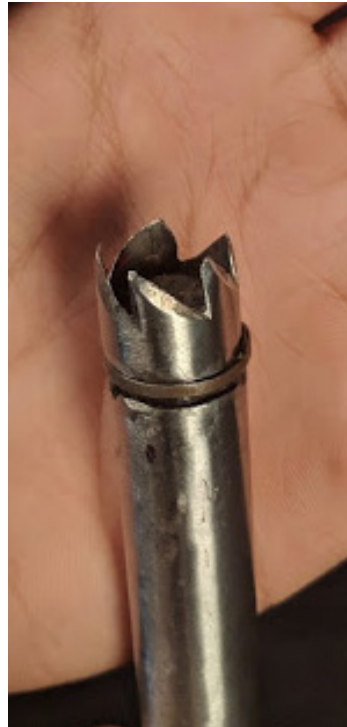

***16mm dia, replaceable blade edge***



***Sharpened 19mm hole saw attached as replaceable blade***

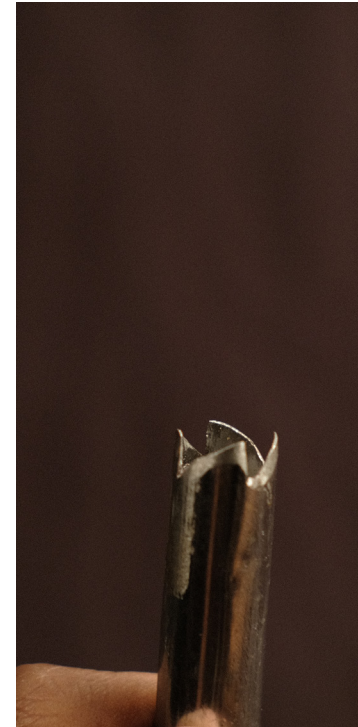

***12mm sharpened blade edge with 4 teeth***



The blade edge mockup which triggered the idea of serrated blade edges



All Circular blades kept side to side

In house testing of holesaw based blade edge with a mount made from sheet metal.

Test was done to check for two things:

1) If an inner plunger is really required for separation, or can the cutting blade alone eject the seed through calyces.

and 2) If rotation of blade edge is necessary for effective separation



Experiemnt with handmade serrated blade, available blade from repurposed hole-saw and grinded circular pipe

As it turns out- an inner plunger is required, since the seed pod gets stuck into the circular end of the blade. The same was later tried with a filled inner rod with serrated edge, and voila- no plunge needed.

Also, with a serrated blade edge, rotation was no longer required

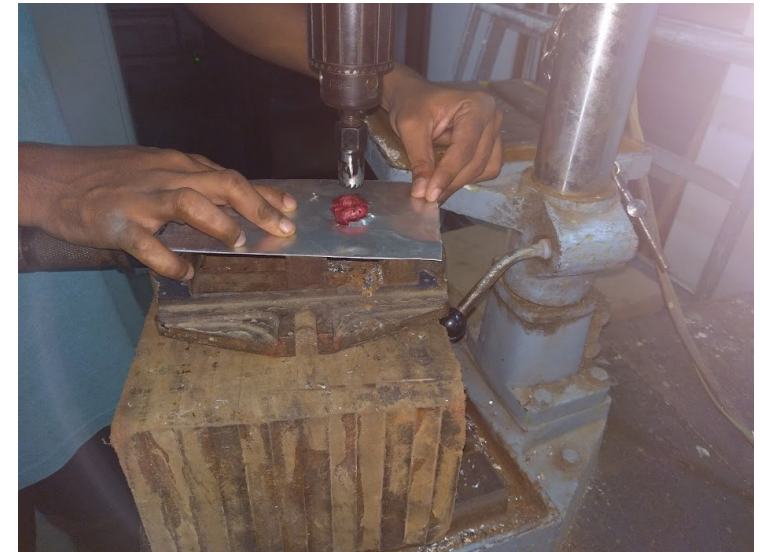

# Tested concepts

*making*



making of workstation based prototype for testing



*Two concepts of plunging with a circular blade were prepared for testing in field*



*Vertical plunge concept*



*Handle concept with variable height enabled by slotted angles*



# Field visit-2

*This time we met the people from village karla who separate the calyces by hand. We also saw the whole process being done and documented it for time based and heart rate activity*

*Date: 10th-12th December*

*location: Wardha and Nagpur*

# Visit Summary-

**Site-**Nivedita Nilayam (associates of CSV, Wardha)

**Ambadi crop land size:** 1/2 acre (2 rows)

**Crop intent:** Household consumption by Nivedita Nilayam members and students in the summer months for making sharbat

**Subject:** Domestic help, kitchen assistance- Mr. Suresh

**Age:** 59yrs

**Mandays for Ambadi separation:**

Approx 2kg fresh Ambadi separated in day and same in evening in sittings of 2 hours each

**Uprooting and transportation:**

Ambadis from lower portion of the shoot mature faster, hence are cut first, seed pods and separated calyces kept in different containers for drying

In the later stages of the season, Whole shoots cut from bottom and seed pods post separation stay on the shoots

**Storage- Intermediary and final:**

Fruits cut as per separation capability of the day. On peak days, other members of NN also do the separation activity

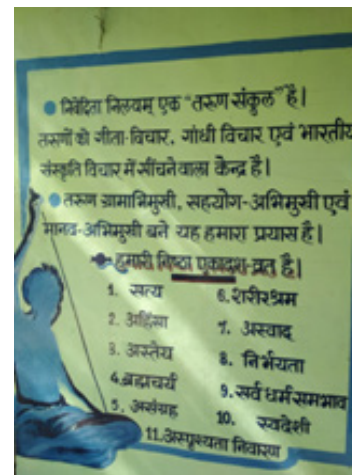

# Visit Summary-

**Site-**Karla village (CSV centre for Ambadi)

**Ambadi crop land size:** 2 acres for 2017

**Crop intent:** Drying and selling Ambadi Calyces or processing into jam/achaar. Income generation for nearby households via manual separation also happens

**Subject:** Homemaker- Jyoti Balujibagade

**Age:** 35yrs

**Mandays for Ambadi separation:**

This season- 21Kg separated in 3 days amongst herself and daughter

**Uprooting and transportation:**

Cut shoots enter CSV Karla in a contract carriage

Villagers come and receive full shoots and take the home (shoots counted in pendeys or jhaadi)

Separated Calyces(wrapped in cloth) and shoots with seed pods attached brought back to centre

Calyces are weighed and money for the villager is credited in the ledger

**Storage- Intermediary and final:**

Open drying of Separated Calyces done at centre premises. Final packets of dried calyces sold directly to buyers who pick it from CSV centre



Indoor drying lot at CSV



Mrs Jyoti

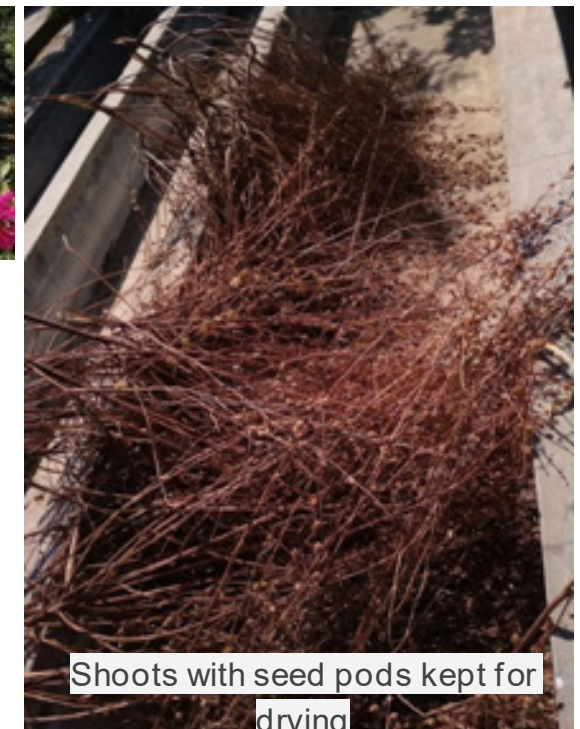

Shoots with seed pods kept for drying

# Connecting the dots in the system

*Tools for cutting the shoot for harvest*



CSV, Wardha



Nagpur

CSV is more primitive in its operations, where a sickle or knife is used for harvesting the crop.

Mr. Deshpande uses a florist knife instead

Mr. Deshpande prefers to cut fruits right below epicalyces and bags them in cloth for sending off to his salaried farmer's home

***Material Handling- Transport***



At CSV, Shoots are cut by hand and carried to the nearest road to the field

***Drying and weighing***



Open air drying- at the CSV KARla centre. Cane basket used on weighing scale for payment of wages and packing into bundles

*Issues in current mode of separation*



Scab formation on Thumbs of workers. Ladies have complained of burning sensation after long hours of separation activity (PS: this is after a week of manual separation this season)

### *Current way of separation*



Jyoti Balujibagade (Age 35) at village Karla, Wardha separating Ambadi Calyces from shoot in her usual posture



Suresh (Age 59) at Nivedita Nilayam, Wardha separating Ambadi Calyces from shoot in his usual posture

Complete shoot is kept on the lap and each fruit is taken in hand one by one for separation

Seed pods are left on the stem for drying later

A trough is used to collect separated calyces..later bound in a cloth or kept in a basket for bringing to CSV for selling

## Heart rate activity estimation



Heart rate monitor used to estimate difference in energy consumption between different concepts and their usual way of separation

Mrs Shila helped us put the heart rate monitor belt on Ms Jyoti

Considerable difference seen for Mr. Suresh but no such difference for Mrs Jyoti according to data

\*\*It may also be noted that Mr Suresh's data for separation by rod was taken after his lunch break

Hence no tangible conclusion can be made from the heart rate monitor, but it surely made the process look more scientific and hence, the subjects and associates paid attention to us actively.

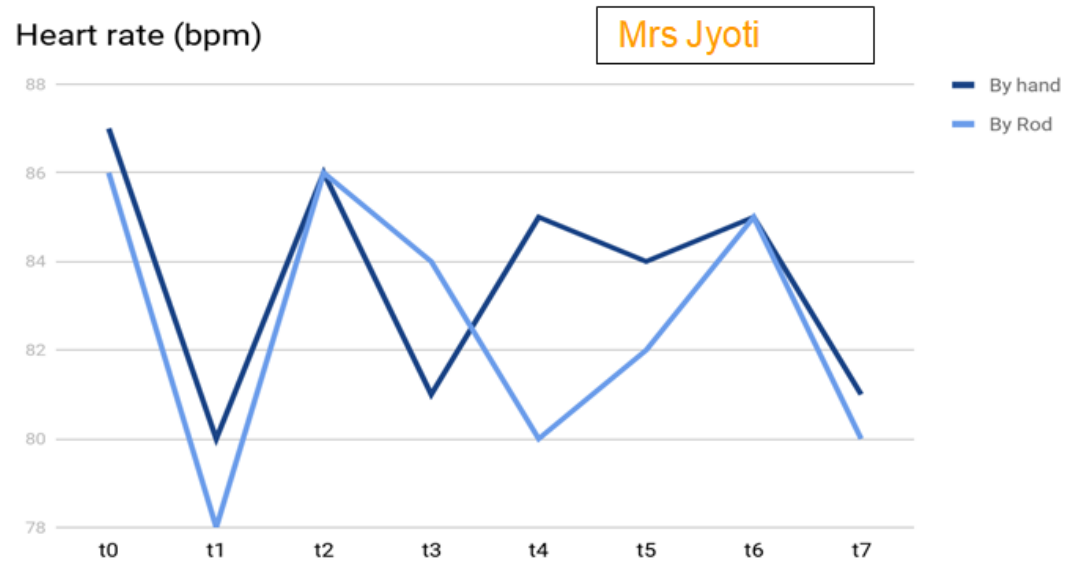
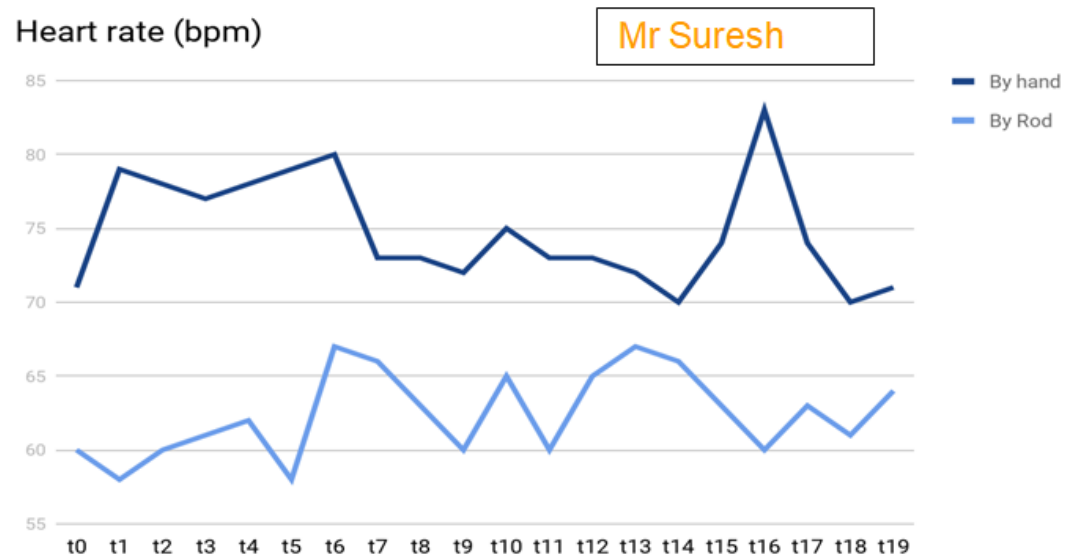

### ***Time wise productivity***

#### ***Mr Suresh (kitchen assistant):***

Separating 120 Ambadis by hand,  
averaged 8.70 seconds per fruit

Separating 120 Ambadis by the rod,  
averaged 8.10 seconds per fruit

#### ***Mrs Jyoti (Villager):***

Separating 50 Ambadis by hand,  
averaged 8.30 seconds per fruit

Separating 50 Ambadis by the rod,  
averaged 6.54 seconds per fruit

data was recorded in a lap fashion. Mr Suresh did 120 by hand in lots of 28, 42 and 50. While he did the rod experiment with 120 in one go.

Jyoti ji did both datasets in quick succession and in one go of 50 each

***Both sets of data do not show statistically significant difference at 95% confidence level.***

***Though empirically, Both users observed the rod tool to be much easier to use as compared to separation by hand***

# Concept feedback- handle



handle in seating posture in use by Mr Suresh

Handle concept fared better than the plunge concept across both users. Certain mechanical difficulties could not allow a fair apple-to-apple comparison of the concepts with manual separation and separation by a rod alone, hence it has not been included in the heart rate or time analysis



handle concept tried by other members farmers



handle (raised platform) in use by Mr. Suresh

it was also observed that raising the platform would allow for additional space beneath the handle machine for keeping a seed collecting vessel.



In use by Mrs jyoti

# Concept feedback- plunge



Plunge concept became harder to push once fruit was kept at the bottom. This may have occurred due to some tolerance issue as well (since o bushes were present in the metal-to-metal joints) - a note taken for further product development.

The overall form also did not augur well with mr. Suresh or Ms Jyoti, as they were overwhelmed with the serrated rods alone. When made to choose between the handle and the plunge concept- they chose the handle one.

# Final Concept



**Manufacturing drawing**

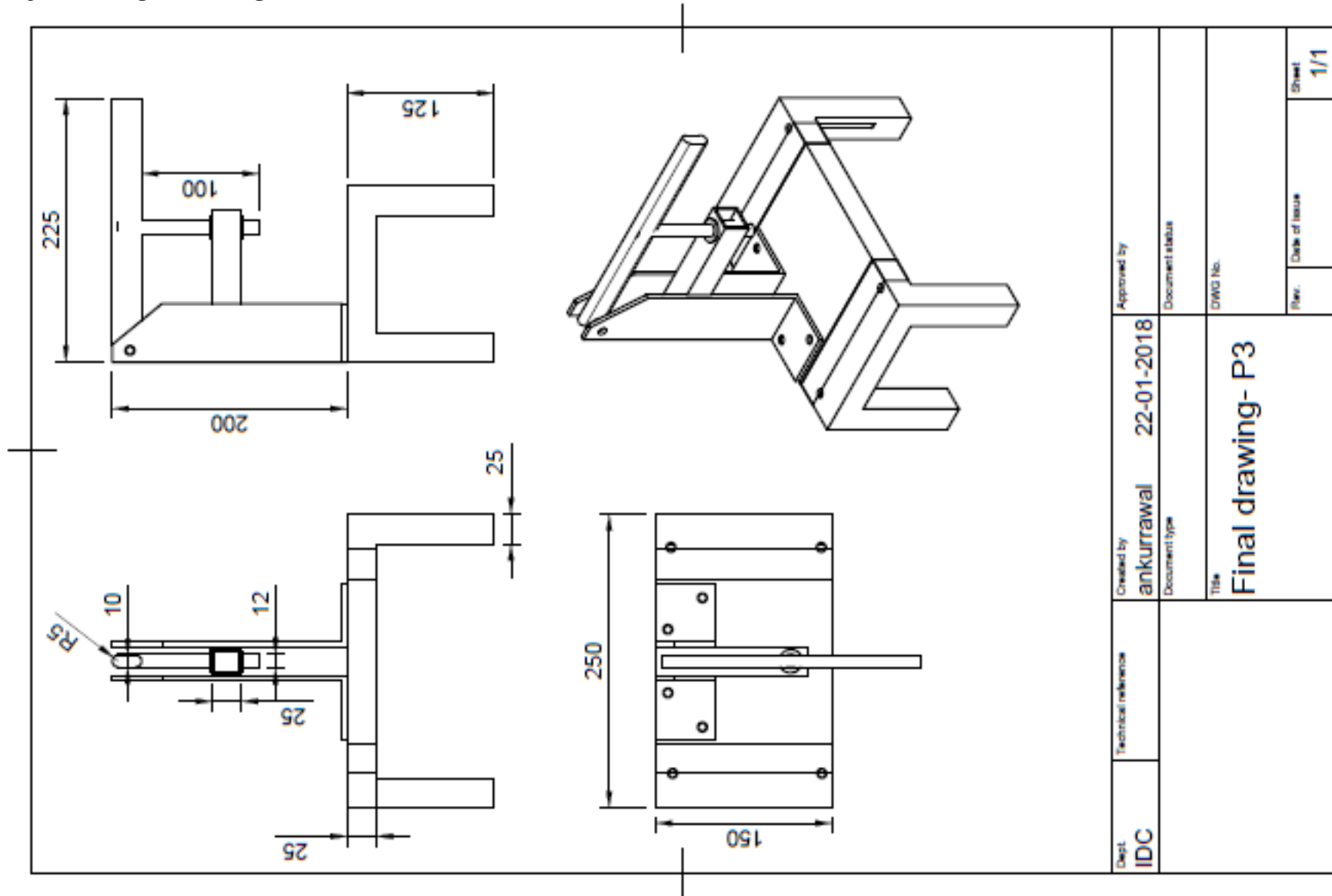

Dept. <b>IDC</b>	Technical reference	Created by <b>ankurawal</b>	22-01-2018	Approved by	
		Document type		Document status	
		Title <b>Final drawing- P3</b>		DWG No.	
		Rev.	Date of issue	Sheet	<b>1/1</b>

# Ergonomic Audit

*Container Orientation was tested for ease of access, time taken per unit and restricting the number of hand shifts*



Fresh Ambadi fruit container and calyx container on either sides of machine  
(slower, requires hand switching)



Ambadi fruit and Calyx containers on same side of machine  
(faster, and does not require hand switching)

*Dimensions for an array of seating options and worktable height*



From top left: seating stool for working on floor, stool height for table top arrangement, seat for table top, table height, seat height for lower workstation, lower workstation, shoulder height for posture

## *Ergonomic Audit*

Seated on the floor



Most  
Comfortable



With stand with stool  
Seat height- 19 cm



With stand on floor



Without stand on stool  
Seat height- 19cm

## *Ergonomic Audit*

Seated on a table/  
workbench



With stand on table  
Table height- 81cm  
Seat height- 72cm



Without stand on table  
Table height- 81cm  
Seat height- 44cm



✓  
Most  
Comfortable



Without stand on table  
Table height- 81cm  
Seat height- 72cm

*Muscles at work*



User felt slight strain in upper arm triceps upon extended use



In lower positions, wrist muscles also flexed beyond comfort

Based on strain incurred in various positions, the user's feedback helped -

***Usability inspiration from Day to Day items in the user environment***

Stove lighters use a spring loaded striker, which releases the piezoelectric charge in an instant. The same mechanism could be adapted in a hand held calyx separator



Actuation by palm



Actuation by thumb

# Additional work

*Ideation sketches for hand-held form using same pipe bore technique*

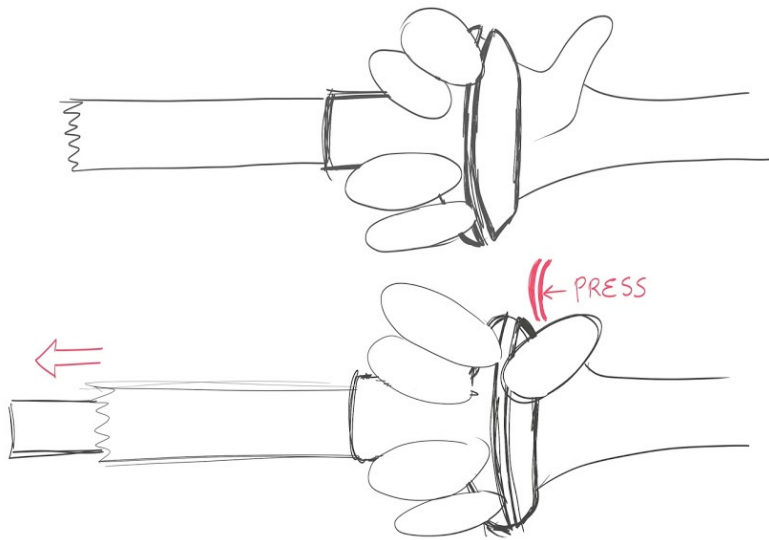

Handheld form actuation and working- spring loaded plunger concept

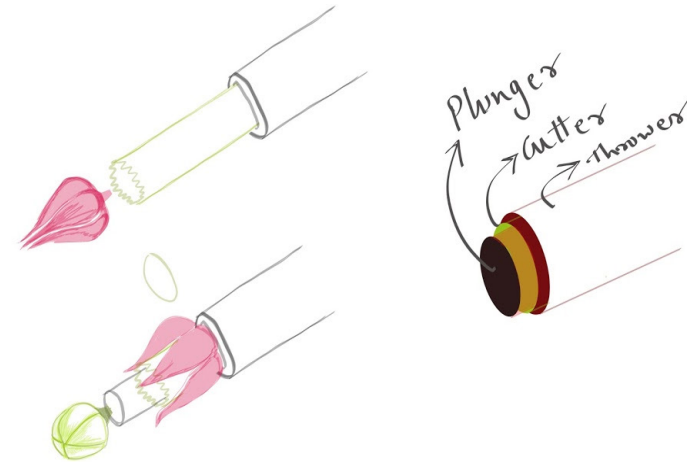

Plunger, cutting head and thrower for ejecting calyxes once separated

***Renders of a frugal approach to the hand held concept, where a silicon gun is modified and repurposed for a plunge and bore type operation***

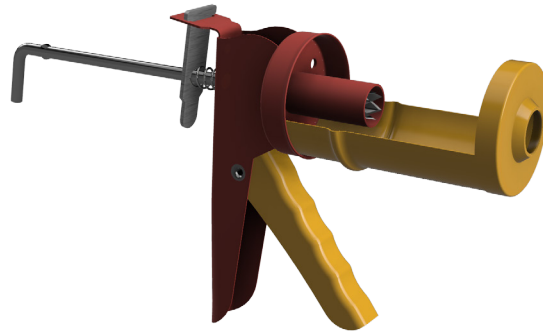

Concept with retracted blade

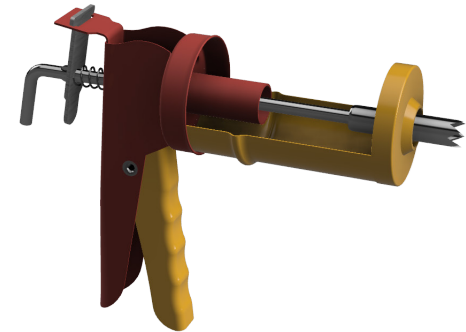

When pressed, the blade edge pierces through the hold in front

# References

## ***Commercial alternatives:***

<http://www.thesurvivalgardener.com/survival-plant-profile-florida-cranberry/>

<https://www.sowexotic.com/product-page/fresh-hibiscus-fruit-hibiscus-sabdariffa>

<https://lansdownefarm.wordpress.com/2016/05/10/rosella-jam/>

## ***Agricultural machine design inspirations:***

<https://www.youtube.com/watch?v=nn7GmuXYKLQ>

[https://www.alibaba.com/product-detail/MAYJOY-SUS304-Peach-Mango-Apricot-Seeds\\_60112442530.html?spm=a2700.details.maylikehoz.8.697a8c3ewoaYBH](https://www.alibaba.com/product-detail/MAYJOY-SUS304-Peach-Mango-Apricot-Seeds_60112442530.html?spm=a2700.details.maylikehoz.8.697a8c3ewoaYBH)

[https://www.alibaba.com/product-detail/cherry-seed-removing-machine-fruit-seed\\_536065662](https://www.alibaba.com/product-detail/cherry-seed-removing-machine-fruit-seed_536065662)

## ***DIY core removal applications***

<https://food-hacks.wonderhowto.com/how-to/pit-apricots-plums-nectarines-other-stone-fruits-like-chef-0156873/>

<https://www.thecoconuttool.com/wordpress/wp-content/uploads/2016/06/ToolWithCoconutPackaged-1.jpg>

## ***Market conditions and Developmental Economics***

[http://www.fao.org/fileadmin/user\\_upload/inpho/docs/Post\\_Harvest\\_Compodium\\_-\\_Hibiscus.pdf](http://www.fao.org/fileadmin/user_upload/inpho/docs/Post_Harvest_Compodium_-_Hibiscus.pdf)

## ***Post harvest management***

<http://pib.nic.in/archieve/others/2012/mar/d2012031309.pdf>

<https://www.amazon.in/Postharvest-Management-Processing-Technology-Chavan/dp/817035787X>  
(IITB Library)

***Cost benefit Analysis of Agronomic ventures***

[http://iad.ucdavis.edu/files/4415/0065/2866/Michael\\_Wallace.pdf](http://iad.ucdavis.edu/files/4415/0065/2866/Michael_Wallace.pdf)

Similar research for Filipino market:  
<https://www.slideshare.net/bardotgov/development-of-production-post-production-and-utilization-technologies-of-roselle-hibiscus-sabdariffa-l-in-region-10-juanita-b-salvani-fe-n-abragan-antonieta-s-tumapon>

***Playlist of youtube videos referenced:***

[https://www.youtube.com/watch?v=nJFq6iv-VI4E&list=PLROC8NmxF12uDWyfxP6RqPH-hAU64bx\\_0g](https://www.youtube.com/watch?v=nJFq6iv-VI4E&list=PLROC8NmxF12uDWyfxP6RqPH-hAU64bx_0g)

***List of patents:***

Sorrel harvesting machine (jamaica):

<http://www.google.com/patents/US9629390>

Decorticator:

<http://www.google.com/patents/US4173177>

