



DESIGN OF HEADGEAR & PERSONAL PROTECTIVE SUIT FOR WILD HONEY BEE HARVESTERS

ARJUN PRASANTH

|

GUIDE- PROF. SANDESH

APIS DORSATA



HOW IS IT DIFFERENT?



Known for their aggressive defense strategies and vicious behavior

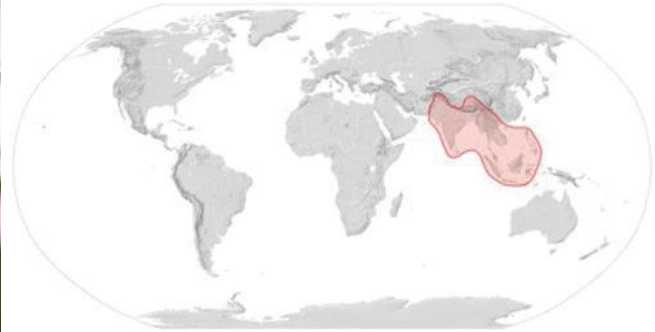

Main weapons are stingers that are up to 3 mm long

Key Pain:

1

2

3

4

Type:



BEE



WASP



HORNET



ANT

SIZE

APPROXIMATE
DURATION

SOUTHERN FIRE ANT
5 mins

MEXICAN HONEY WASP
5 mins

DIGGER BEE
2 mins

SONORAN BUMBLE BEE
5 mins

TROPICAL FIRE ANT
5 mins

BALD FACED HORNET
4 mins

ASIATIC HONEY BEE
10 mins

MEXICAN TWIG ANT
5 mins

SUNFLOWER WASP
5 mins

FOUR-TOOTHED MASON WASP
0-1 mins

HAIRY PANTHER ANT
10 mins

PAPER WASP
5-10 mins

BULLDOG ANT
5 mins

BULLET ANT
300 mins

MOST SMALL BEES
2 mins

RED FIRE ANT
5 mins

ASIAN GIANT HORNET
10 mins

NORTHERN PAPER WASP
5 mins

GIANT HUNTING ANT
10 mins

WESTERN HONEY BEE
10 mins

RED PAPER WASP
5-10 mins

METRICUS PAPER WASP
0-1 mins

TARANTULA HAWK
5 mins

WESTERN PAPER WASP
2 mins

WHITE FACED BEE
2 mins

TRAPJAW ANT
0-10 mins

ECITON ARMY ANT
5 mins

YELLOW JACKET
10 mins

GIANT HONEY BEE
10 mins

VELVET ANT
30 mins

WARRIOR WASP
150 mins

BEE HIVE

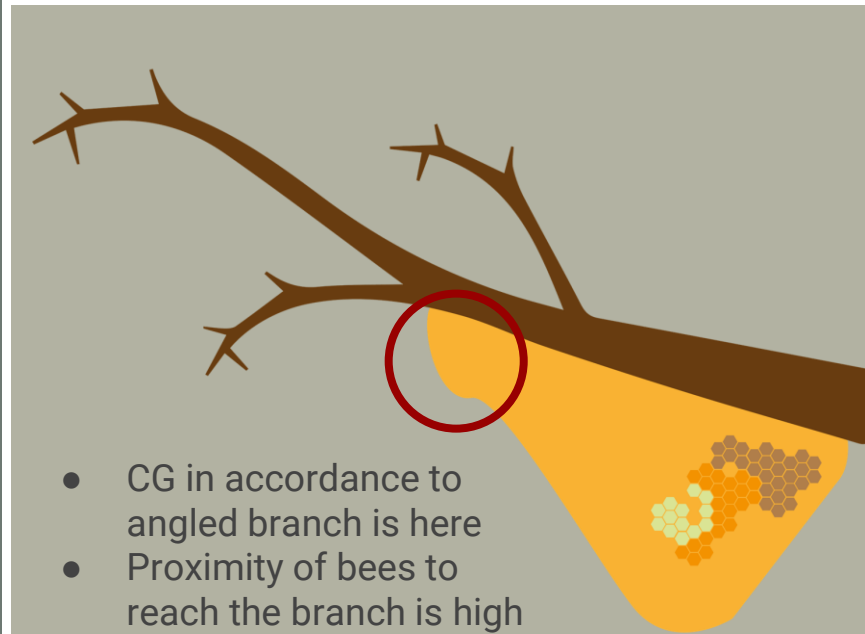
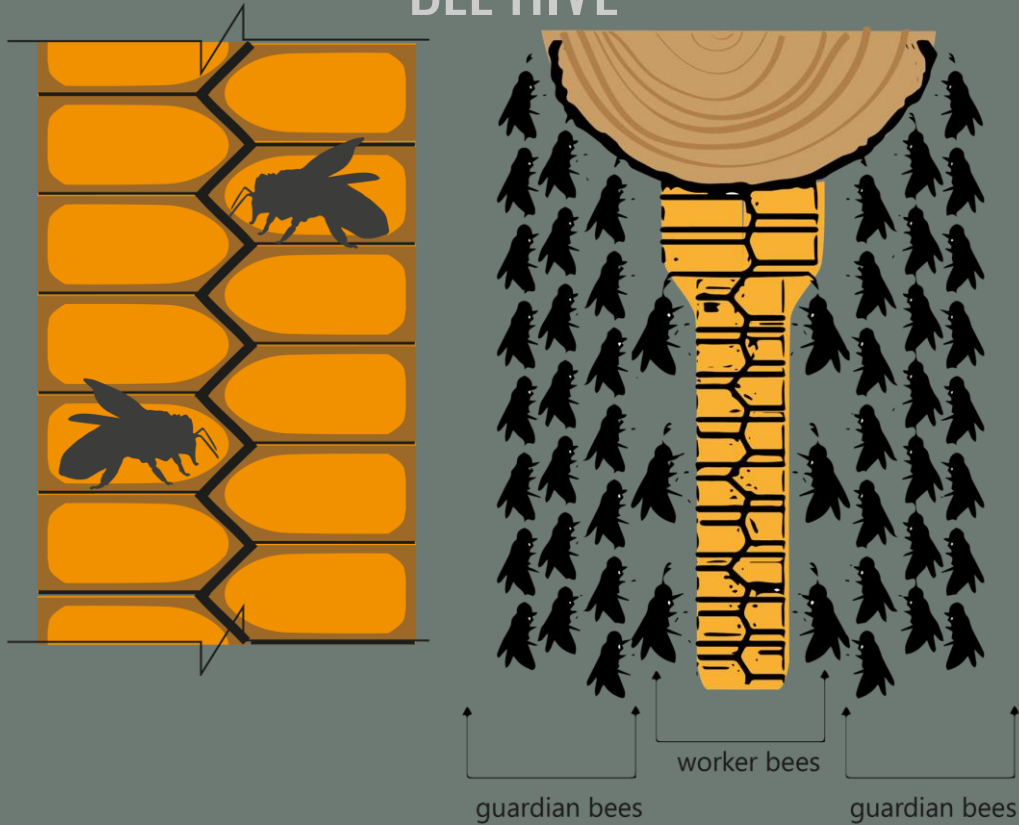

- CG in accordance to angled branch is here
- Proximity of bees to reach the branch is high at this zone

70% of the stock honey is present in the 30% of the total beehive located upper portion of a slanting branch, bulged portion.

POLLEN & PRODUCTIVITY

SUMMER



Amla



Mango



Karvand

WINTER



Utran



Mehandi



Bawachi

RAINY



Nirgudi



Teakwood



Yellow gulmohar



WILD HONEY HARVESTING

TRADITIONAL METHOD

IN CLIFFS





WILD HONEY HARVESTING

TRADITIONAL METHOD

IN TREES





VISIT TO WARDHA

EQUIPMENTS USED



PROCESS OF COLLECTING HONEY



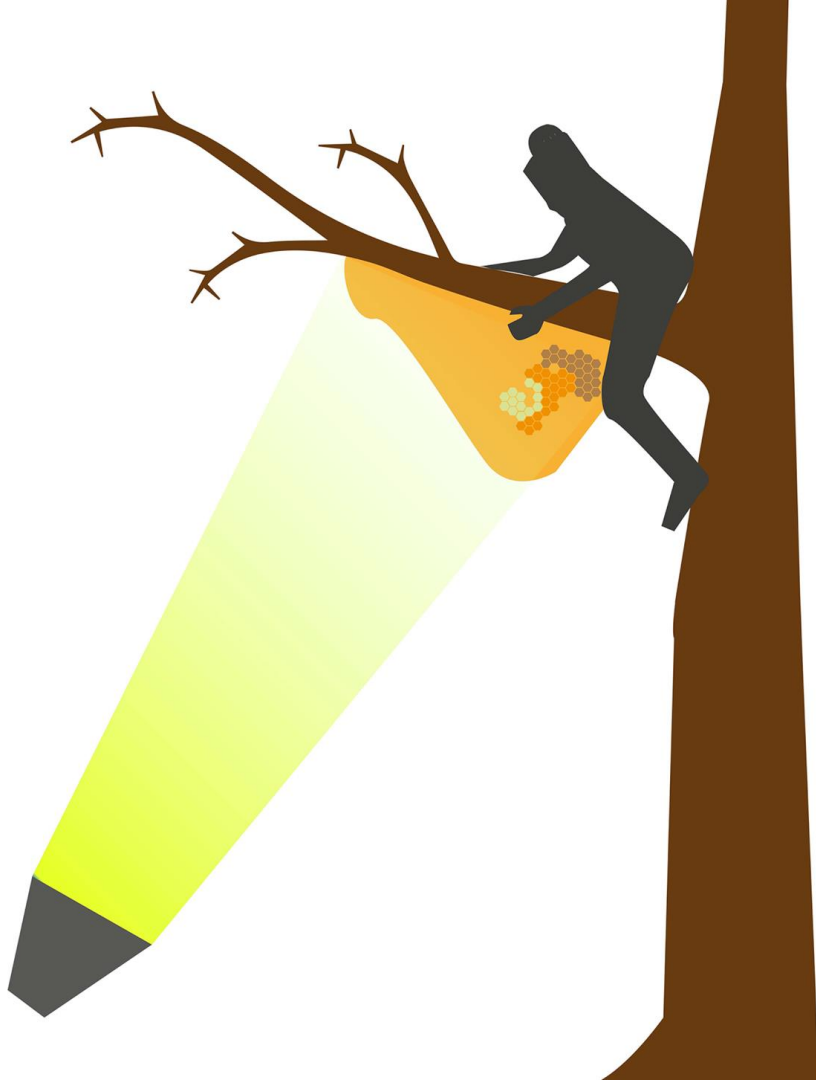

FACTS

- Honey collecting process happens at night most of the times, so no smoke is used to scare away the bees.
- Honey harvested during March, April, May, June, November and December.
- 70% of the stock honey is present in the 30% of the total beehive located upper portion of a slanting branch, bulged portion.
- Second harvesting is done after 30 days as the rebuilding of the cut portion of the nest takes place during this time.
- 10-15 trees a month is climbed by a honey harvester on an average.
- ~10 min to climb up the rope, ~20 min to cut the bulky honeycomb, ~7min to climb down the rope
- On an average of 500 protective suits are made and distributed in a year

EXISTING SUIT

MAKING





Metal punching tool



Frame with GI mesh is riveted with the helmet



Mesh is bend 90° to the plane of surface of helmet



Making the hole in GI sheet from the mark of the hole in the helmet



Holes are drilled in the helmet for air ventilation



Aluminium plates as framework



Holes are drilled and tied with the framework and canvas



EXISTING SUIT



ISSUES

- Difficult to be worn by a single person and needs help from another person as the head part is slightly bulky head part and tight elastic at the sleeve end
- Tight waistline elastic of the upper part of the suit impedes the process of wearing it comfortably
- Lack of air circulation due to double layered denim in the entire length of the suit used for clothing.
- Double layered denim throughout the length of the suit results in suffocation for the harvester
- The bee veil does not provide adequate viewing angle





ISSUES

- The seating position for the assembly of mesh, helmet and GI sheets for 3- 4 hours
- 8-10 hours taken to make(cut, assembly and stitch) a single suit
- Excess usage materials (GI sheets, rivets, nut and bolt)
- Bending the exposed sharp edge of GI using plier one by one
- Thick GI wire mesh used(results in corrosion)





ISSUES

- Aluminium strips placed over the helmet vaguely creating sharp edges
- 45 drills, 25 rivets and 2 nut and bolt in the head part of the protective suit.
- Only hand stitching can be carried out for stitching denim at the head part
- The entire process of manufacturing the head part is done vaguely without any proper jig or measurements resulting in non uniformity of design from one suit to another
- Needs an experienced personnel to make the head part

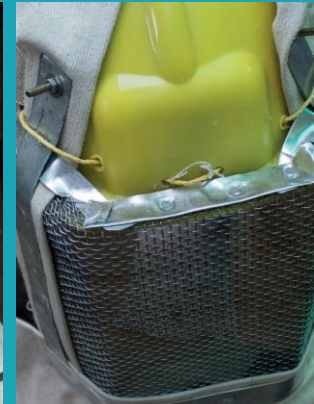

DESIGN DIRECTION

POSITIVE TAKEAWAYS FROM CBEED

Fabric chosen- Canvas

- The cloth withstands from minor injuries while crawling on trees
- Durable to withstand the poking of bees and twigs of trees
- Wild honey harvesting generally happens during night time , so outside temperature factor need not be considered

Protective helmet

- Hard hats are designed to protect the head against falling objects and the side of the head, eyes, and neck from any impacts, bumps, scrapes, and electrical exposure. Head protection is extremely important because traumatic brain injury (TBI), a common outcome of impact to the head, can cause physical, cognitive, social, emotional, and behavioral effects that may result in short-term or permanent impairment.

PROJECT GOALS

- The suit to be fully packed with no sort of air gap in the sense to not to allow any chance of wild bee entering in the suit.
- To be worn for approx 40 min during the entire process, so it should be comfortable wearing
- The benchmark price of the protective suit to be below than the current price of Rs2500 (Rs1700- raw materials, Rs1400- labour cost, Rs 400- inventory cost)
- The protective suit should withstand from injuries due to any accidents while climbing up or down from the trees, primarily head part(Safety of the personnel)
- The material chosen should be durable enough to withstand the poking of bees and twigs of the trees while climbing trees
- To ensure smooth working with several beehives and to get higher efficiency
- Quick to wear the suit before the harvesting process single handedly.
- The suit needs to be washed after every honey collecting process.

PROJECT BRIEF

- To study the existing wild honey collecting process and find an integrated solution for the development of headgear and personal protective suit for wild honey bee harvesters.
- To ensure safety and personal protection for honey harvesters of central India who has to climb and crawl tall trees in order to conduct the harvesting process.
- To reduce or eliminate injury to body of the collector because of the rough conditions which involves wear and tear through the entire process
- To increase the degree of usability of the protective suit for the honey collector during the harvesting process
- Optimisation and standardization in the manufacturing of headgear and protective suit to enable
 - a) Efficient and easy tailoring
 - b) Quick manufacturing process reducing drudgery for the people who work in the production of suits
, in the context of frugality to keep the cost as low as possible

DESIGN IDEATIONS

INITIAL IDEATIONS

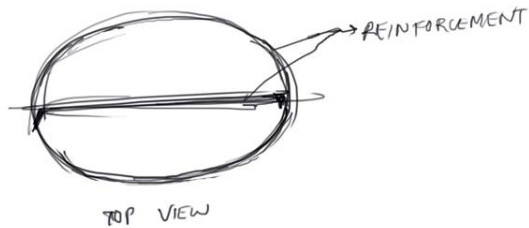
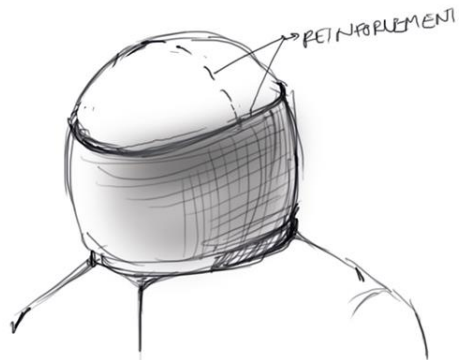
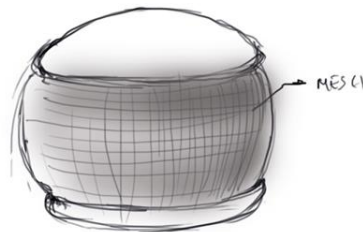
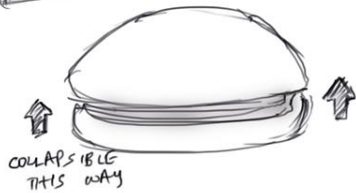
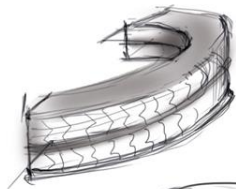

INITIAL IDEATIONS

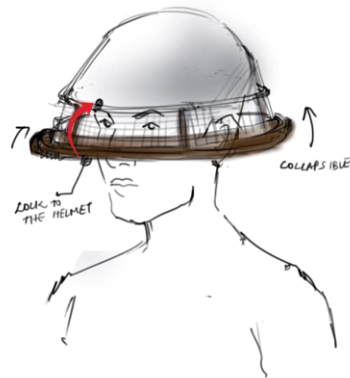
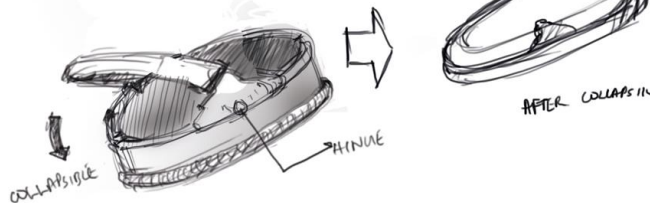
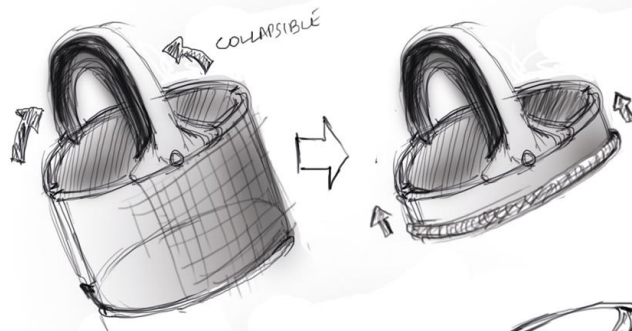
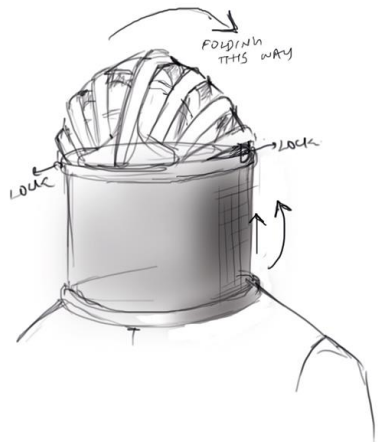

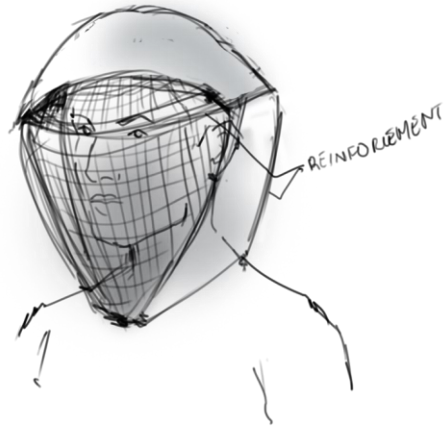
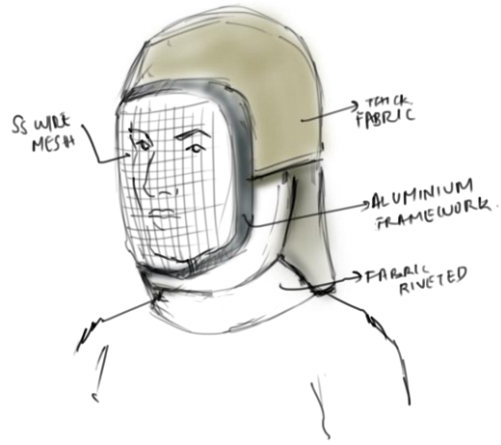

HEAD PART INTEGRATION WITH THE SUIT

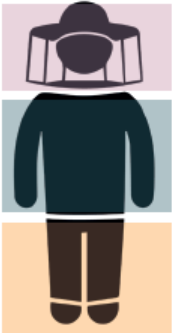

BASIC CONCEPT

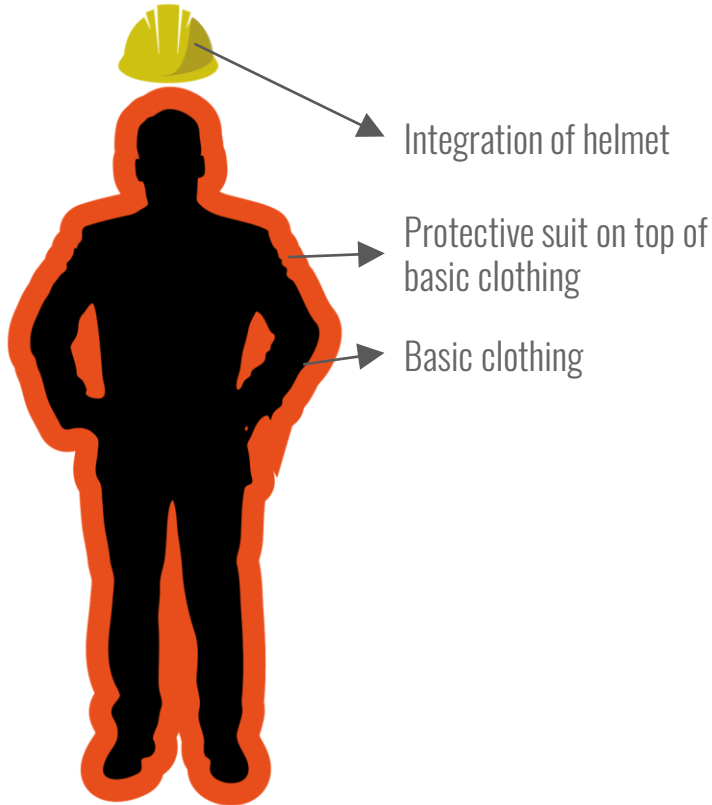

A trade off between safety and comfort to be achieved through

- Thick fabric is used so that even if the bee stings, the sting doesn't reach the other side
- Double layered fabric to be used in the regions of the body where bees sting the most and where stretching of the body parts happens due to the activities of the personnel during the process of honey harvesting
- Integration of hard hat to ensure safety and personal protection for honey harvester, who has to climb and crawl tall trees in order to conduct the harvesting process, .
- Design methodology to increase the degree of usability of the protective suit for the honey collector during the harvesting process

IDEATION 1

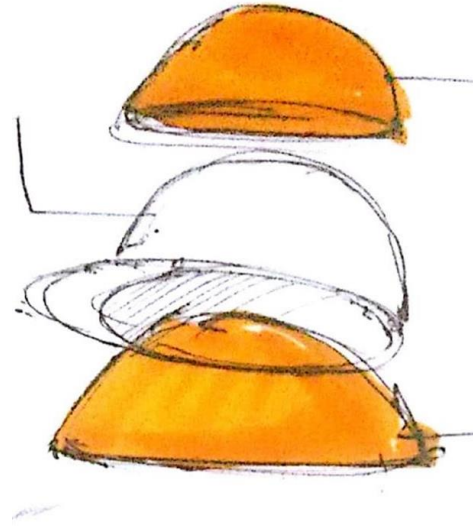
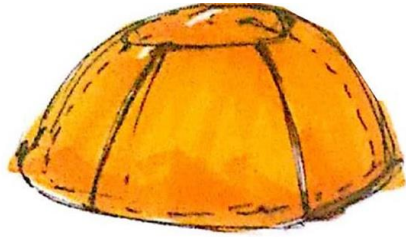



- Protective head part can be made with efficient and easy tailoring.
- Quick manufacturing method which involves processes that are less drudgery

ISSUES



- Plastic mesh will get damaged in time by rough handling and penetration of twigs
- Mesh is not sturdy and is in contact with the face during the movement of head.
- Proper offset from face is not achieved
- Washing of the suit is a problem as the helmet integrated is not removable and has two layers of canvas at the helmet region

IDEATION 2

Easy assembly of parts

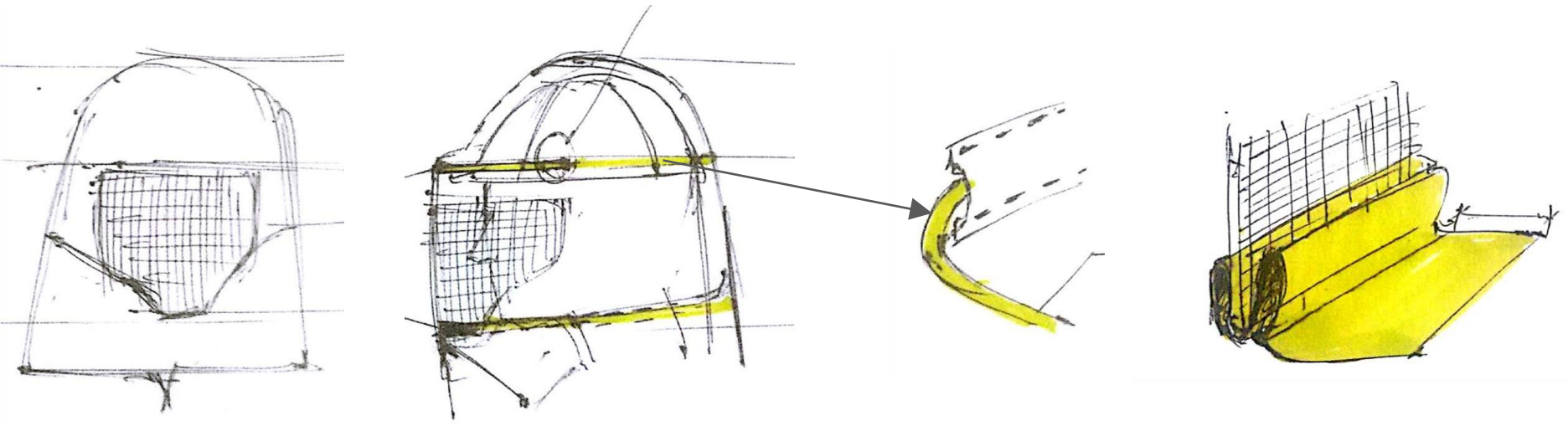

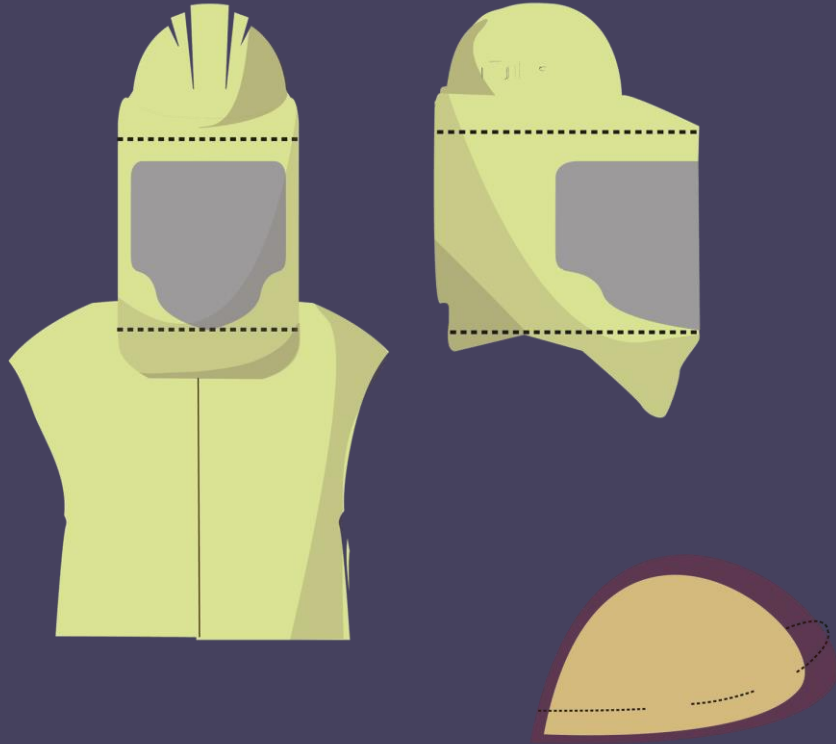

- Protective helmet integrated to the hood and easy assembling of parts
- Aluminium mesh offers sturdiness to the structure
- The materials chosen is durable enough to withstand the poking of bees and twigs and bark of the trees while climbing and crawling during the harvesting process.
- GI wire offers offset from face which is necessary during the movement of head while conducting honey harvesting process

ISSUES

- Difficult to stitch in the curved areas of wire mesh visor
- Wastage of material due to the curved design of the visor
- Washing of the suit is a problem as the helmet integrated is difficult to remove because of GI wire runs and connects two parts, and has two layers of canvas at the helmet region and on top of that an additional layer of canvas layers that covers the entire head part

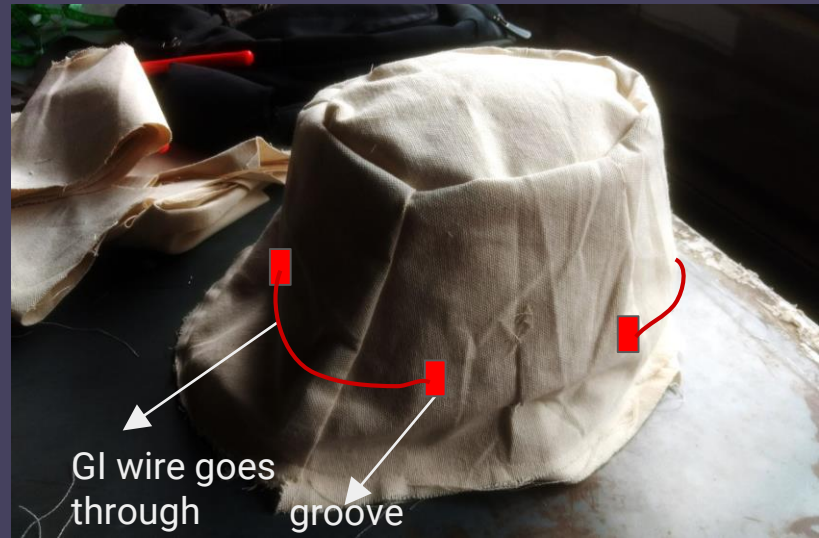

IDEATION 3

To enable quick fixing of canvas with the helmet



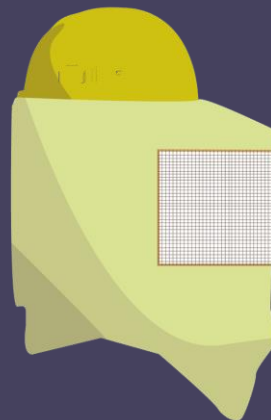
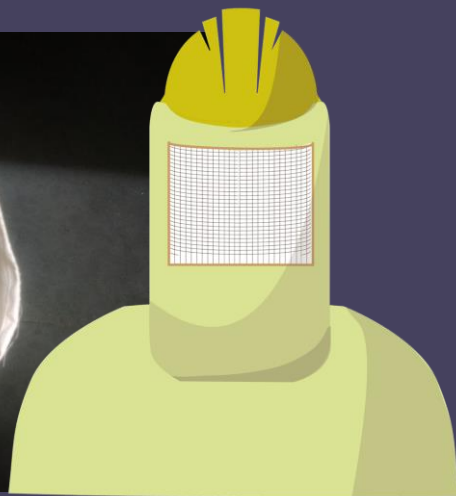
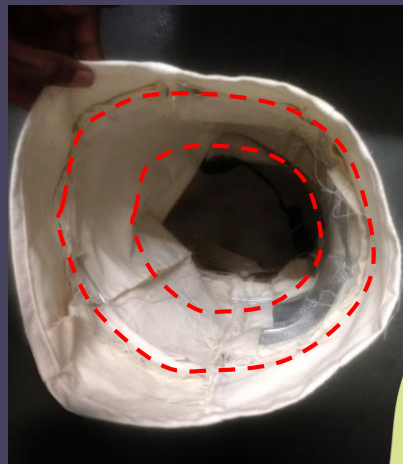

Strategic placement of channel





- Ease of manufacturing
- Ease of assembling of helmet and the rest of the part of head protection
- Washable without the contact of helmet as it is removable
- Less wastage of material as the shape of veil is rectangular, which can be cut accurately, reducing the drudgery for the workers during production
- The materials chosen are durable enough to withstand the poking of bees and twigs and bark of the trees while climbing and crawling during the harvesting process.
- Aluminium wire mesh helps the bee collector for better vision and to stay secured and can be easily cleaned
- Metal wire offering offset from face which is required during harvesting process

IDEATION 4

No connection between helmet and hood



Sequence of wearing the head part of the protective suit



As the helmet is completely detached from the suit, wearing the helmet becomes an option and there is a high possibility of not wearing it during the honey harvesting process



IDEATION 5

Providing rigidity with juxtaposition of additional framework with the canvas structure

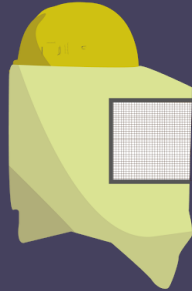
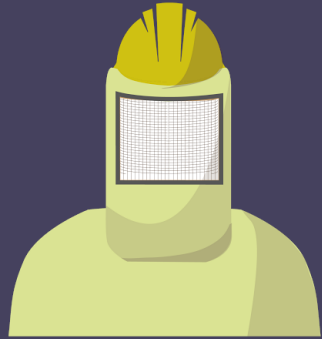

Sequence of manufacture of head part



Helmet



Canvas with veil connection



Riveting Aluminium framework to canvas



- Quick fixing of canvas with the helmet
- Lightweight and durable
- Easy to wash as helmet can be completely detached from the rest of the suit
- Ease of manufacturing

1



2



3

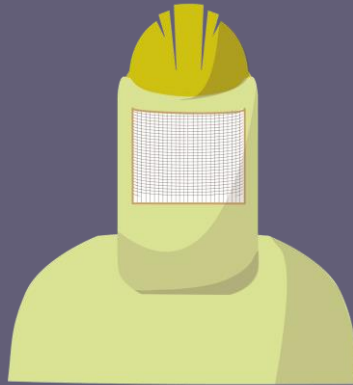

4



5



IDEATION SELECTION

PROTOTYPE TESTING

AT CBEED

IDEATION 3



The prototype

TAKEAWAYS

In discussion with by Dr. Paliwal

Pros

IDEATION

3

- Lightweight
- 2.5 hours taken to make (cut, assembly and stitch)
- 3 drills in the helmet
- Optimisation of materials
- Easy to construct
- More breathing space in the head region
- Aluminium wire mesh used (corrosion resistant)

Cons

- Flexible around mesh region

Pros

Current design

- Sturdiness achieved through thick mesh and GI sheet framework

Cons

- Heavy and bulky
- 8-10 hours taken to make (cut, assembly and stitch)
- 45 drills in the helmet
- Excess usage materials (GI sheets, rivets, nut and bolt)
- Needs an experienced personnel to make
- Congested in the head region
- Thick GI wire mesh used (results in corrosion)

CONCEPT DEVELOPMENT

IDEATION 3 TAKEN FORWARD

TYPE A

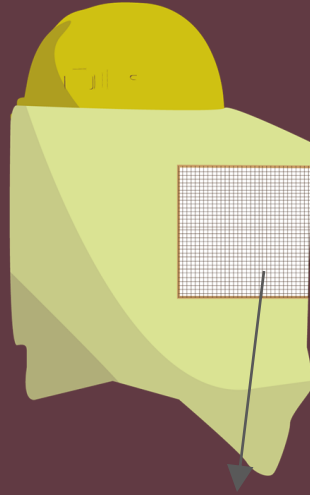
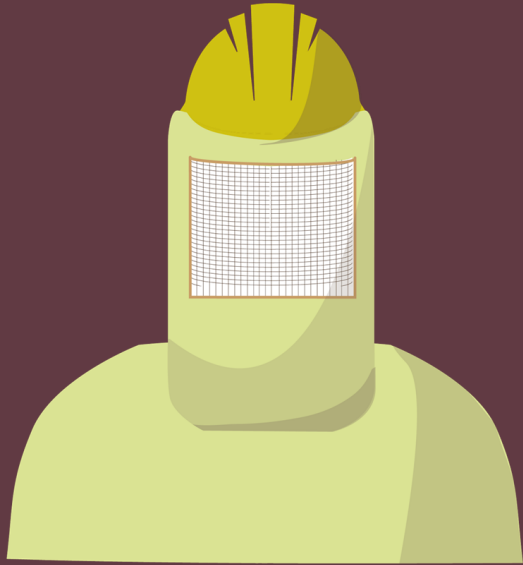

SS wire mesh

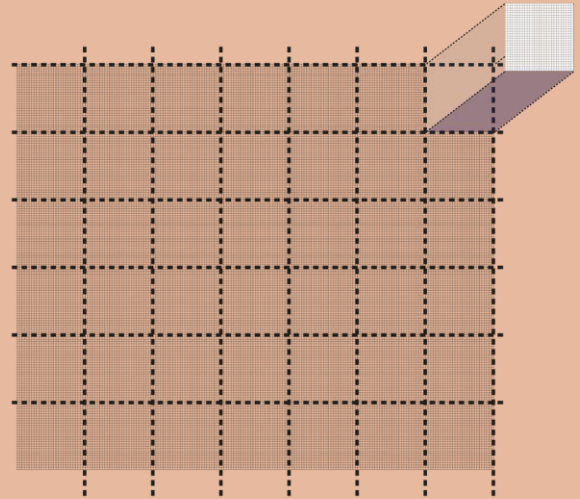

TYPE B

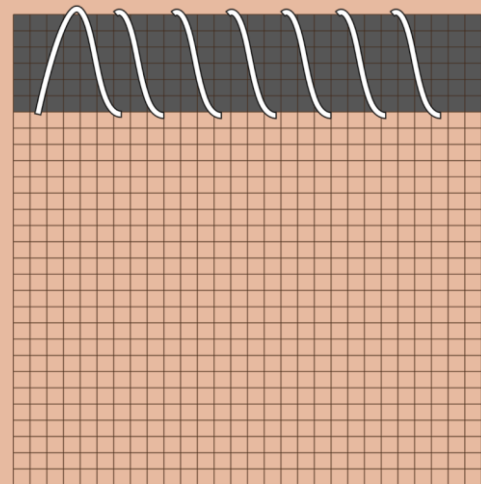
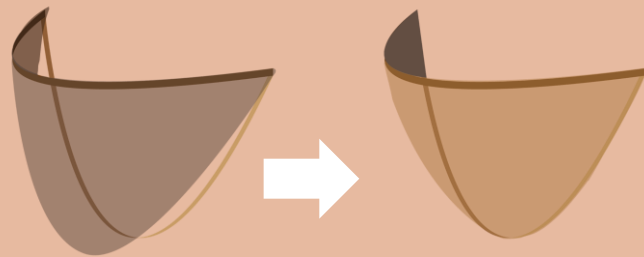
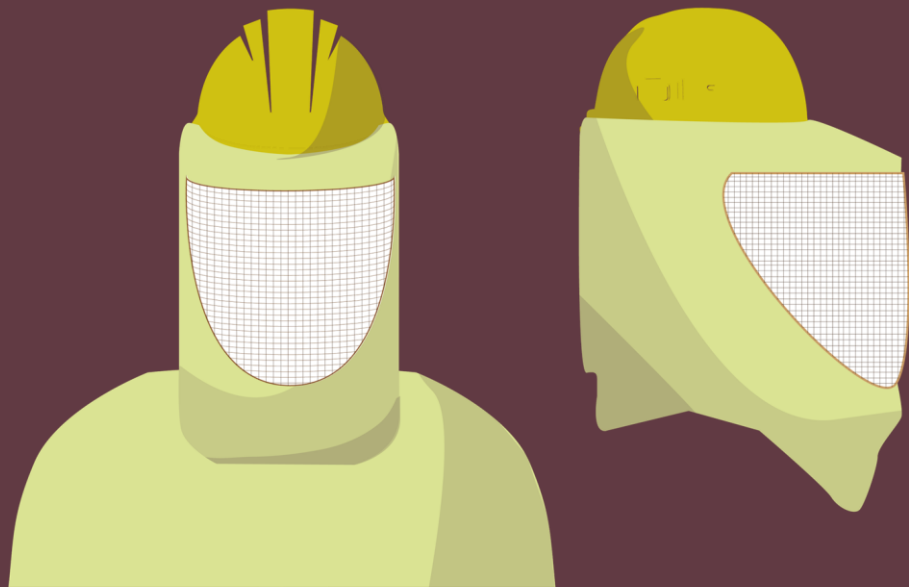



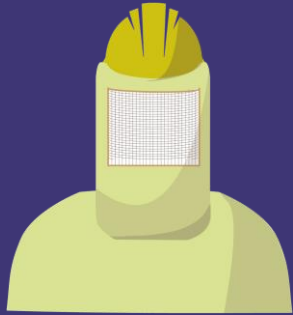

TYPE A



TYPE B

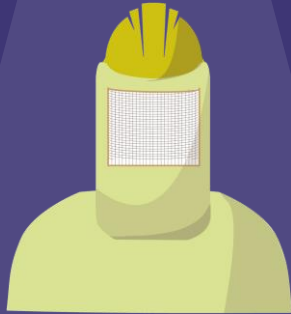

TYPE A

Trade- off between the positive features and manufacturing aspect of the product



TYPE B

CLOTH CUT OUT DRAWING

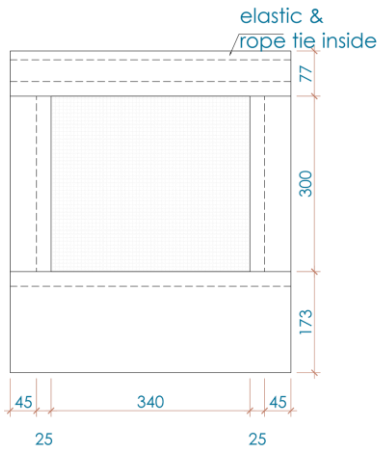

1st PART

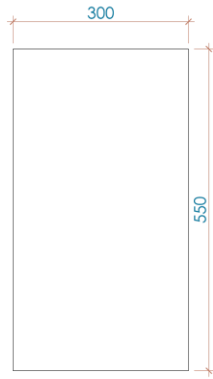

2nd PART

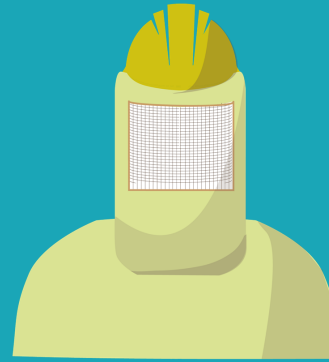

2nd PART 1st PART

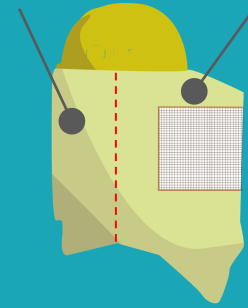

**CONNECTION WITH THE
REST OF THE SUIT**

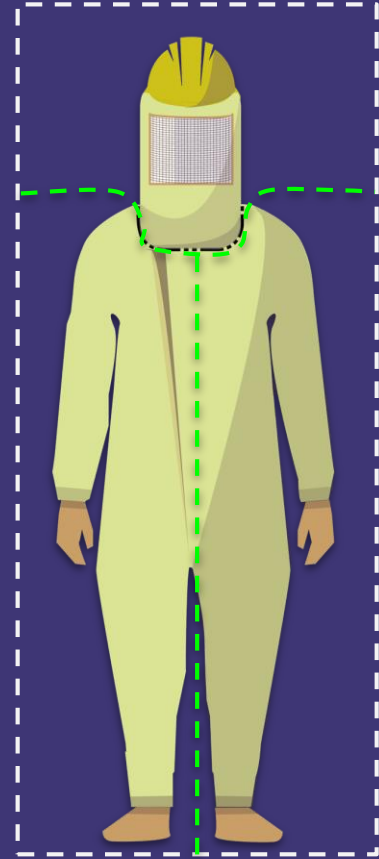
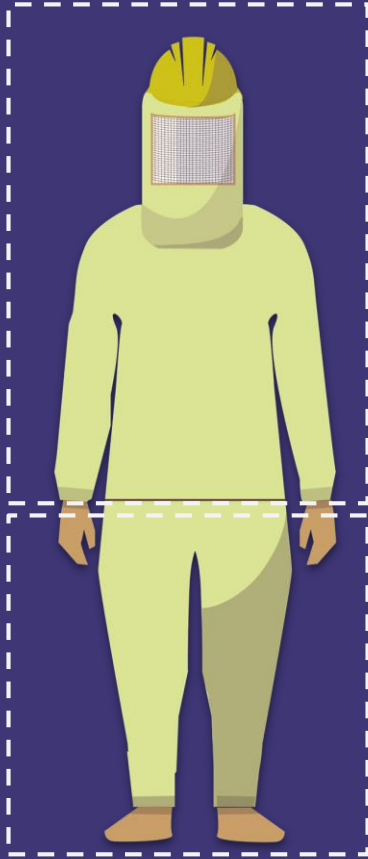

- Difficult to be worn by a single person and needs help from another person as the head part is slightly bulky head part and tight elastic at the sleeve end
- Tight waistline elastic of the upper part of the suit impedes the process of wearing it comfortably

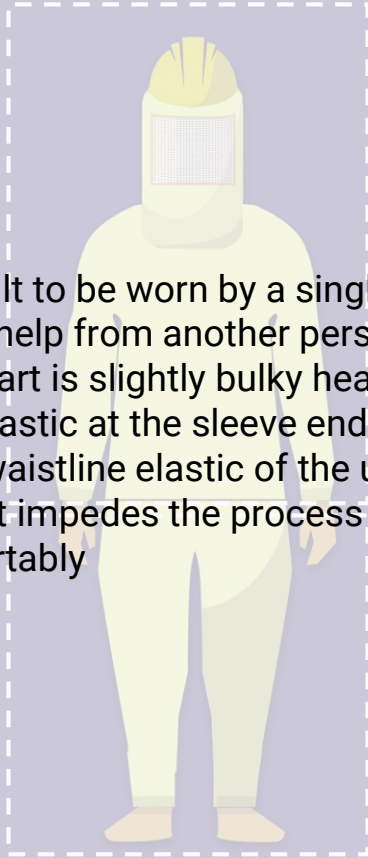

- Easy to be worn by a single person as the parts of the suit are connected by zips, tich buttons and velcros.
- The suit is more flexible during harvesting process activities.
- Easy to put chin strap of helmet and tighten it

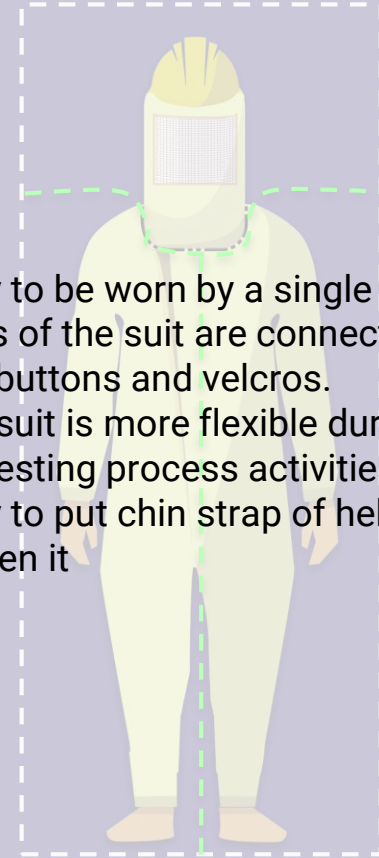



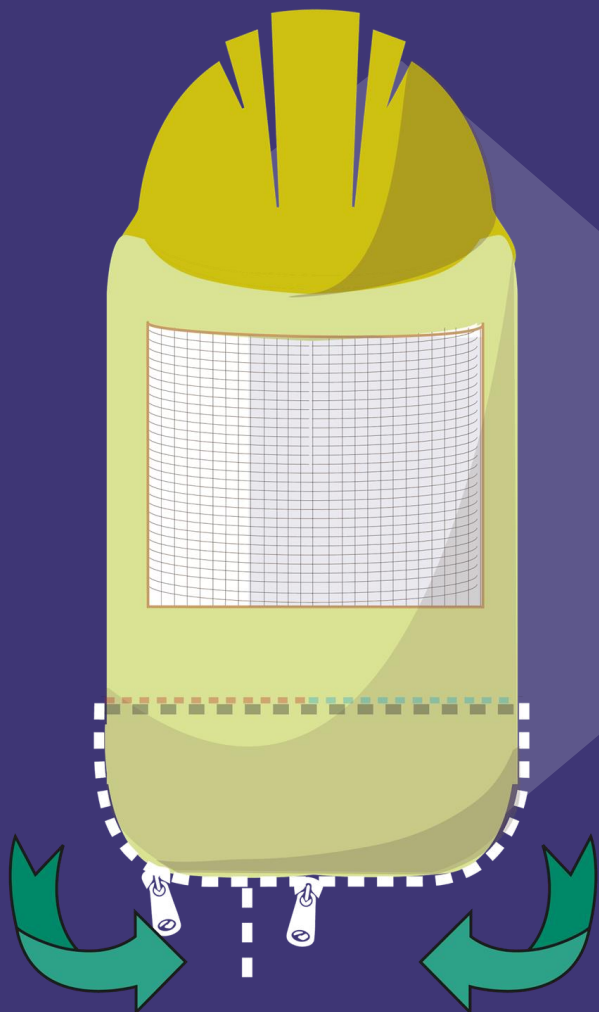

SEQUENCE OF WEARING THE SUIT

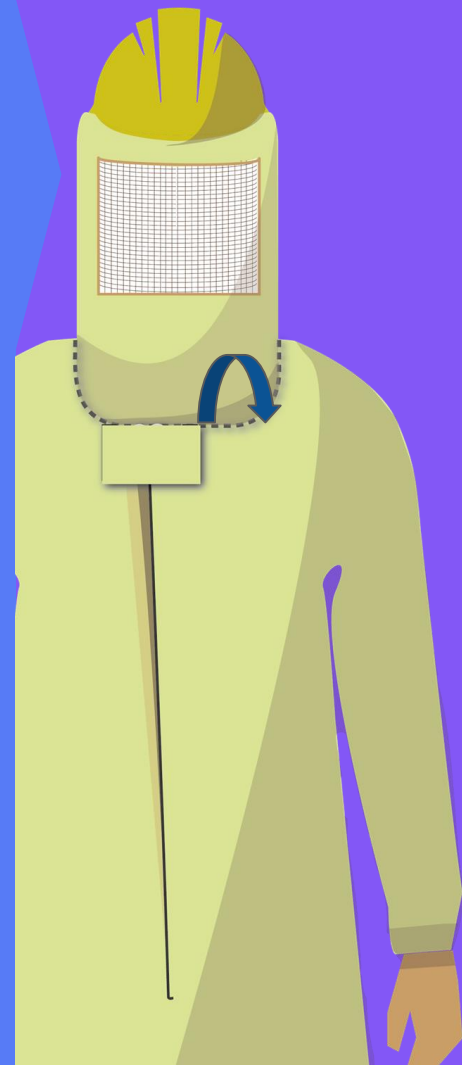
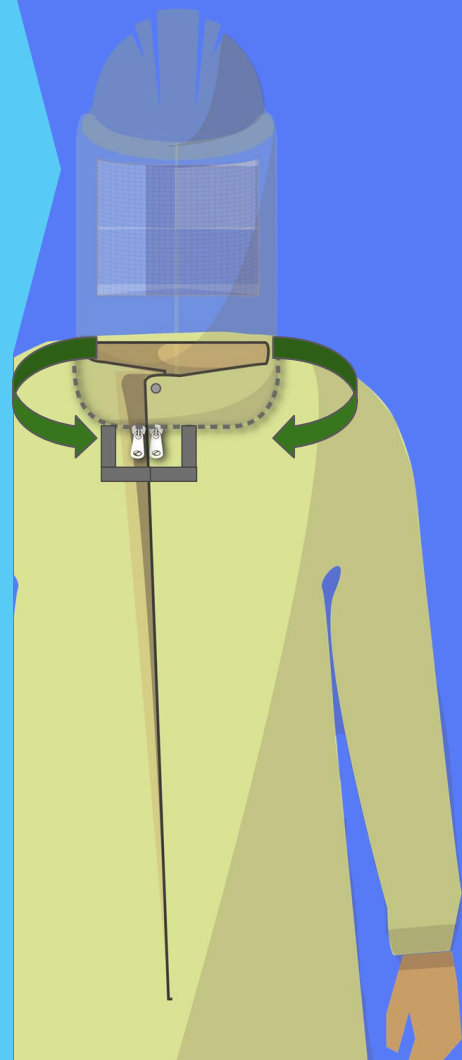
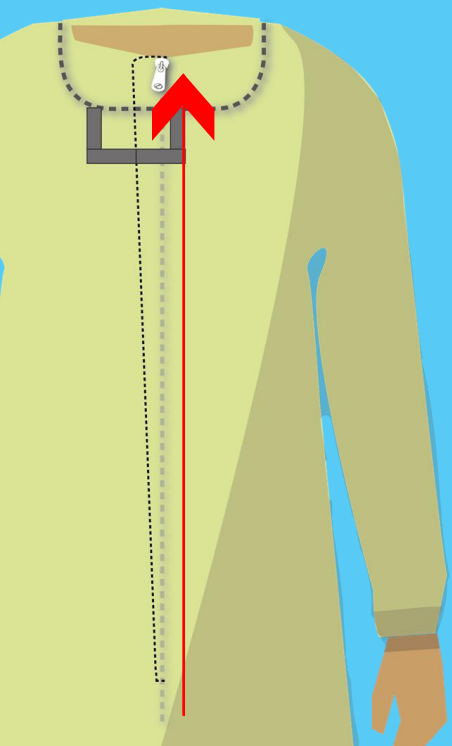

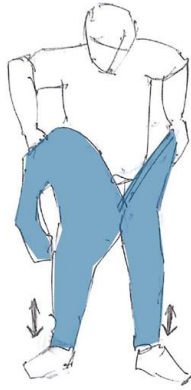

Steps of wearing the suit

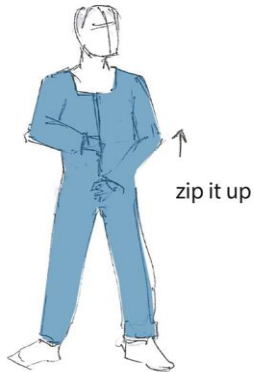

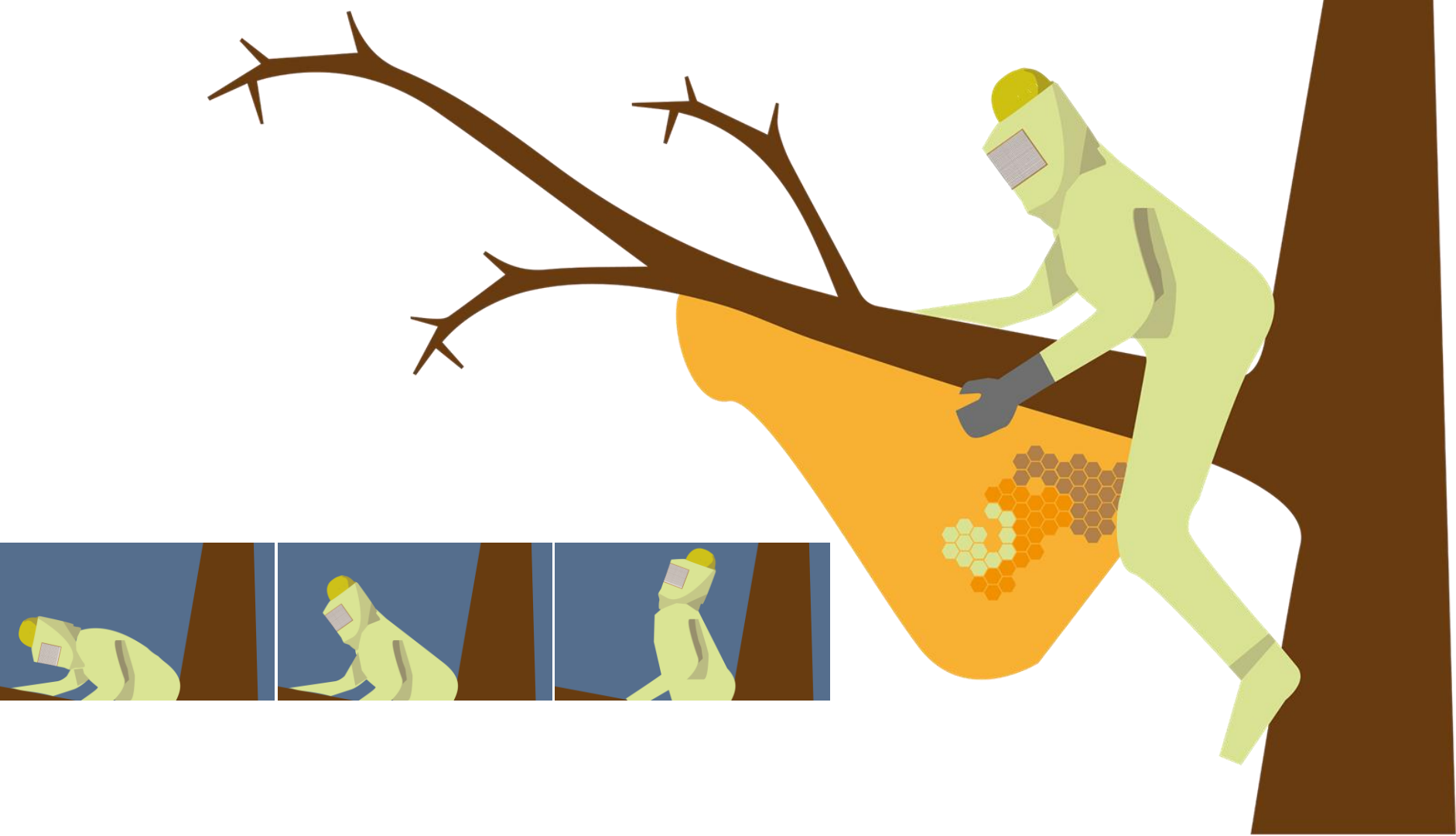

Mock up prototype



DEMONSTRATION AT CBeeD





FINAL PROTOTYPE

DETAILING & MAKING

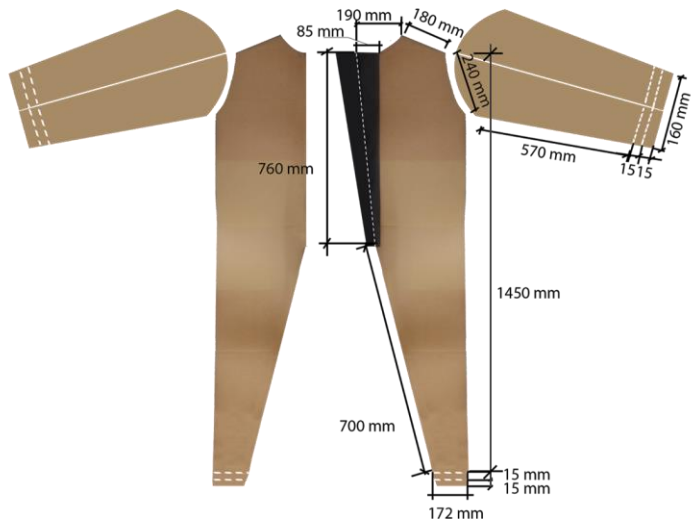

CLOTH CUT OUT DRAWING



FRONT

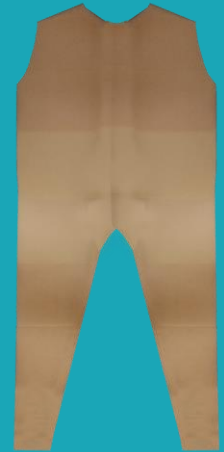

BACK

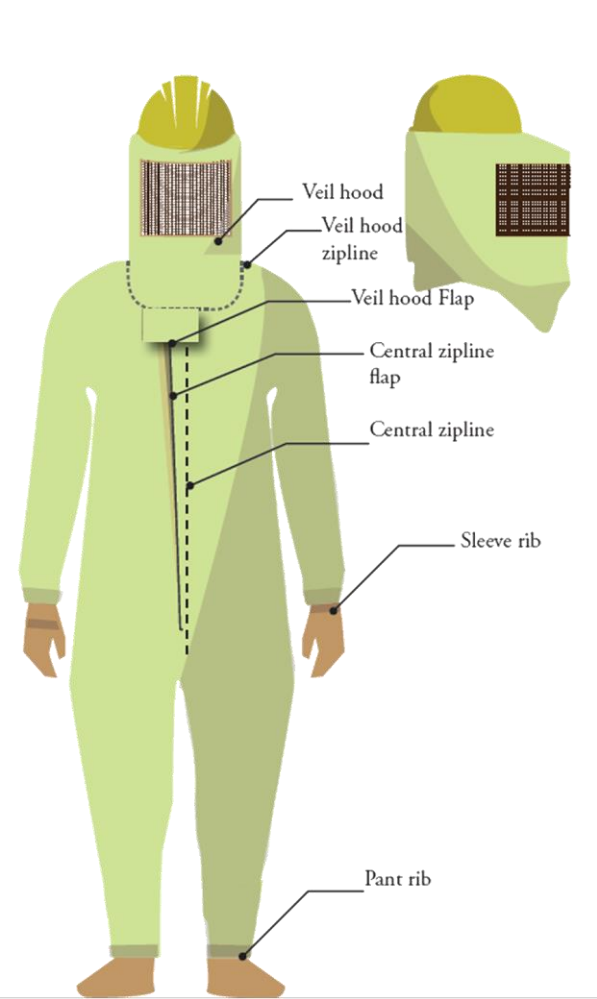



PROTOTYPE TESTING



PROTOTYPE TESTING

ENERGY EXPENDITURE ANALYSIS BY HEART RATE MONITOR

TIME TAKEN TO WEAR THE SUIT

WEIGHT

MANUFACTURING PRICE

Starting- 110 bpm
After wearing the suit- 140 bpm
Climbing- 182 bpm

2 min 15 sec

2.9 kg

Rs 2100

Starting- 135 bpm
After wearing the suit- 145 bpm
Climbing- 180 bpm

1 min 11 sec

1.6 kg

Rs 1950

(will be considerably less
when mass manufactured)





DOUBLE LAYERED CANVAS AREAS

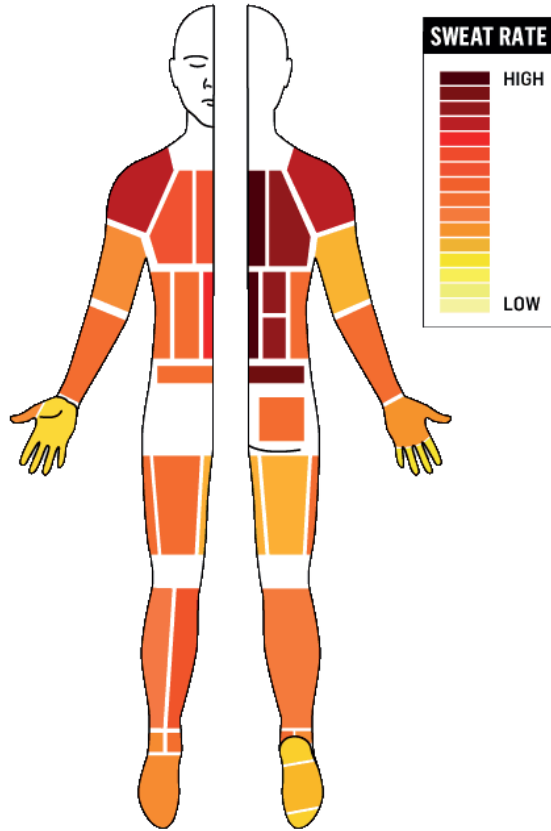

HEAT
MAP

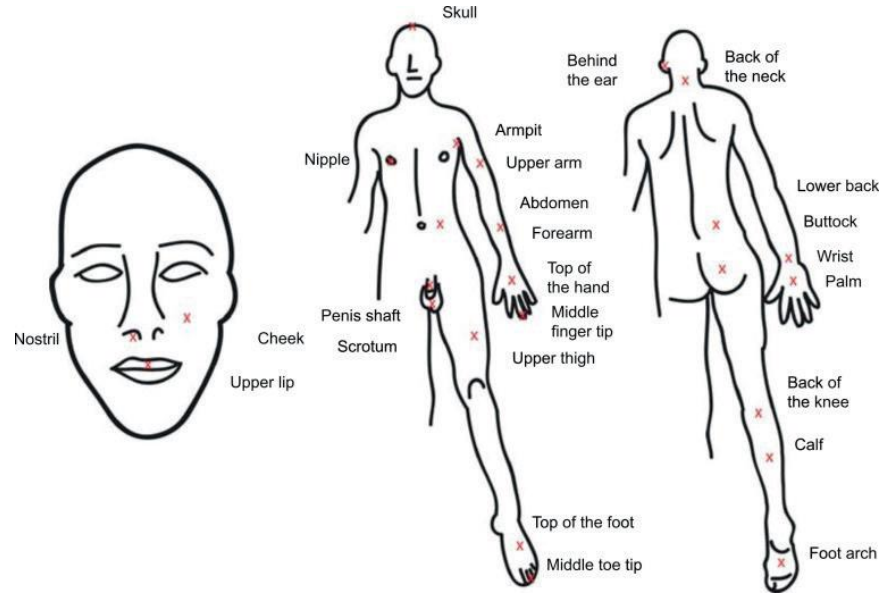

STING LOCATIONS

DOUBLE LAYERED CANVAS AREAS

