



*ATUL PARANJPE 05613802*

**LUGGAGE DESIGN**  **V.I.P.**





**Project III**  
**Luggage design**

**Atul Paranjpe**  
**05613802**

Project Guide  
**Prof. Chakravarthy**  
IDC, IIT Bombay

Co-guide  
**Mr. Satyajit Vetoskar**  
Design Head, VIP Luggage

**Product Design**  
Industrial Design Centre  
IIT Bombay

# JOURNEY



## A. About the project

1. Introduction
2. The thought
3. Objective and expected learning
4. Methodology

## B. Data collection for understanding luggage

1. Terminology
2. Types of luggage
3. Luggage accessories
4. Classification
5. Manufacturing & materials
6. Luggage & interaction

## C. Appreciation

1. Objective
2. User

## D. Analysis & ideation

## E. Product brief

## F. Concept generation

1. Concept 1
2. Concept 2
3. Concept 3
4. Concept evaluation

## G. Final concept

1. Concept detailing
2. illustration

## 1.Introduction

Luggage design as an industrial project with 'VIP luggage' is a project chosen to reconstruct all design learning that happened at IDC and recollecting it through direct implementation in industry. This is a six month project which started at June`07.

### About VIP



'VIP luggage' is second largest luggage brand in the world and the largest brand in Asia. It is highly trusted premium brand present in the markets since 1971.It caters to multiple categories-hard & soft luggage, business bags, duffels, backpacks etc. with focus on style & quality. VIP luggage aims to provide joyful travel through thought full & innovative products. Its no wonder then, that happy journeys begin with VIP.

## 2.The thought (rationale of the study)

I desire to learn design process that involves systematic research, planning and its implementation towards reaching a level that brings actual feasible product that is marketable and profitable as well.

Apart from redesigning and modification of existing luggage there could be new innovations and that is the very intention of this project work.



## objective

To design an **UPRIGHT, HARD/ HYBRID** luggage using **POLYCARBONATE** as material and **VACUUM FORMING** as manufacturing process.

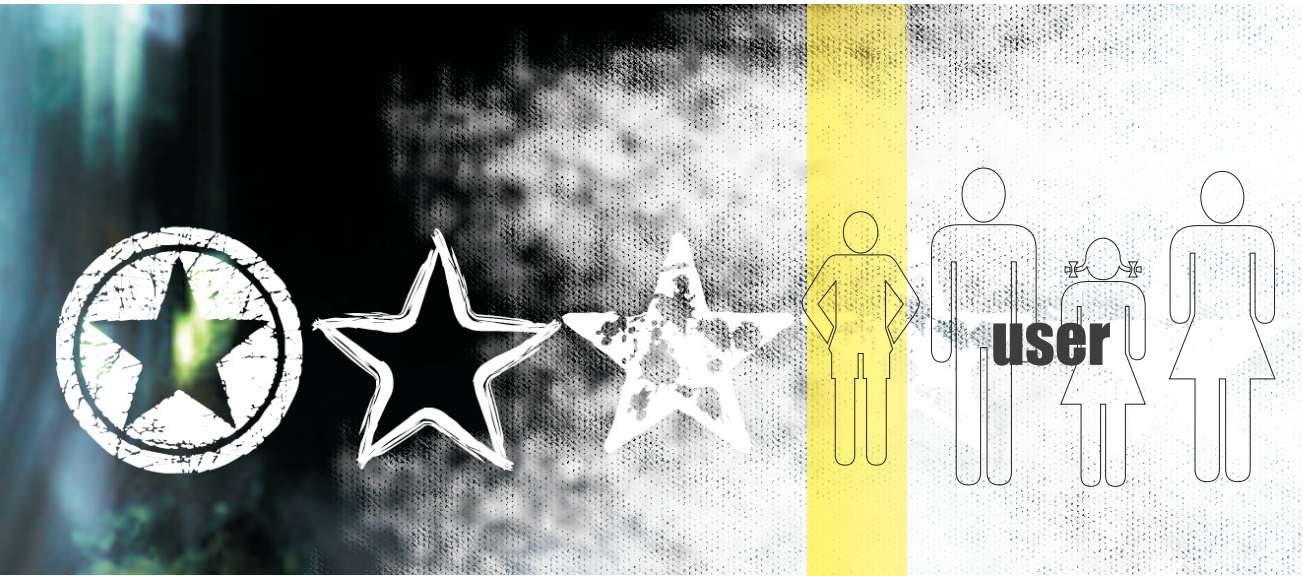

sex: male and/or female

age: 25 to 35 years

personality:

- outgoing, smart
- passionate about traveling
- aware about current fashion, trends

## 4. Methodology

Step 1: Data collection to understand luggage

Step 2: To grasp the detailed idea of the objective

Step 3: To understand the specified user category

Step 4: Analysis and ideation

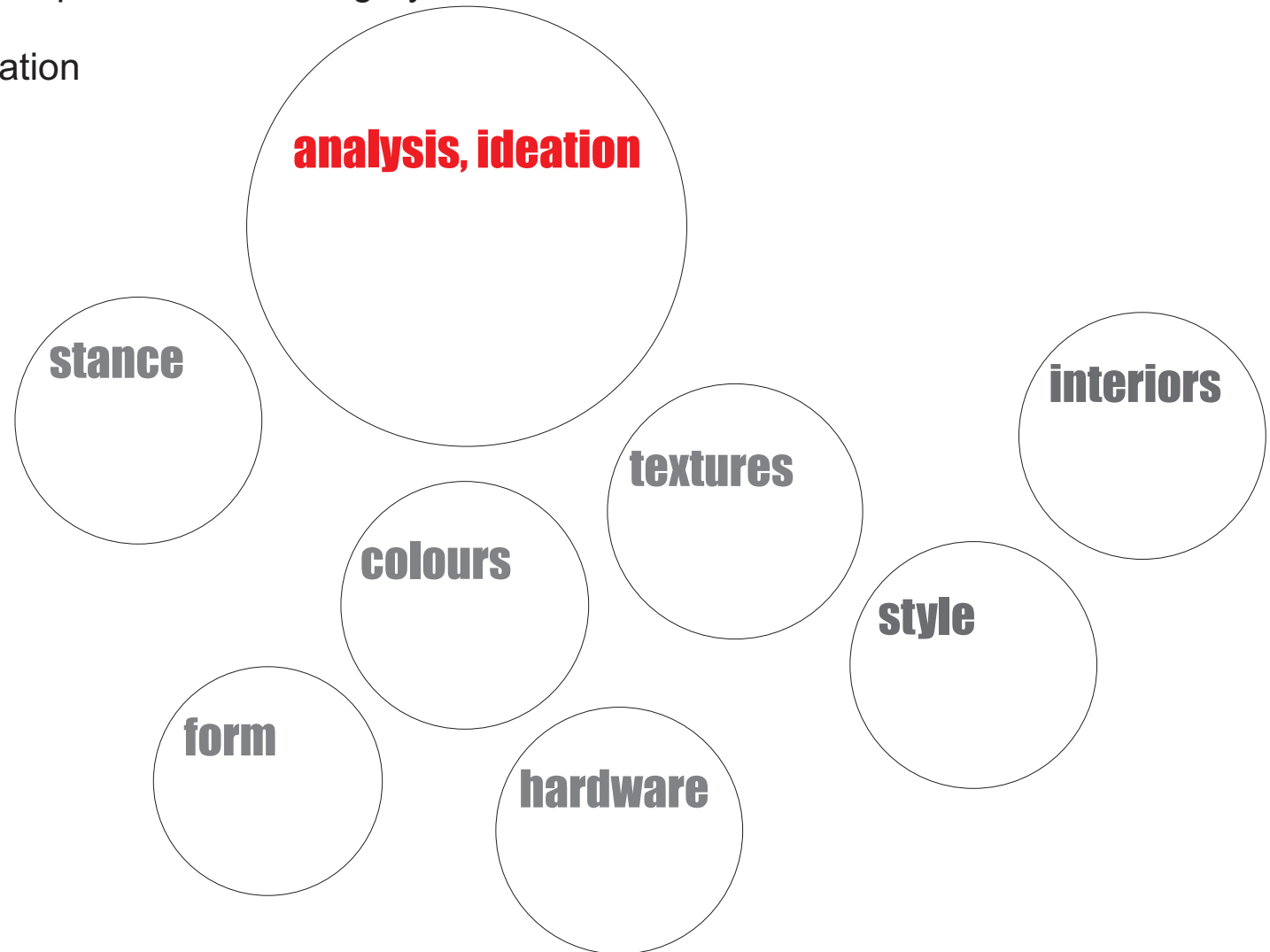

## Step 5: Product brief

## Step 6: Concept generation

3 concept designs are generated, such that each concept will have different concept hardware and style. Adopting idea derived in idea clusters of each component are judiciously merged together to come up with three primary concepts. These concepts are evaluated to get the best possible out of them.

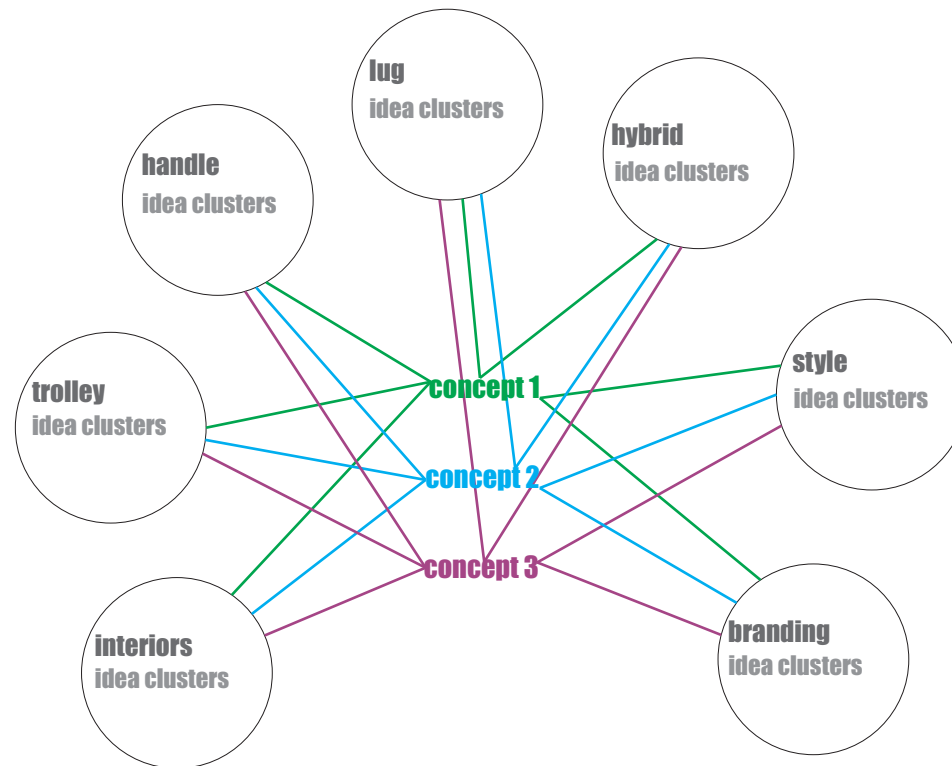

## Step 7: Final concept

choosing the best features out of each concept to blend them together to get the final concept

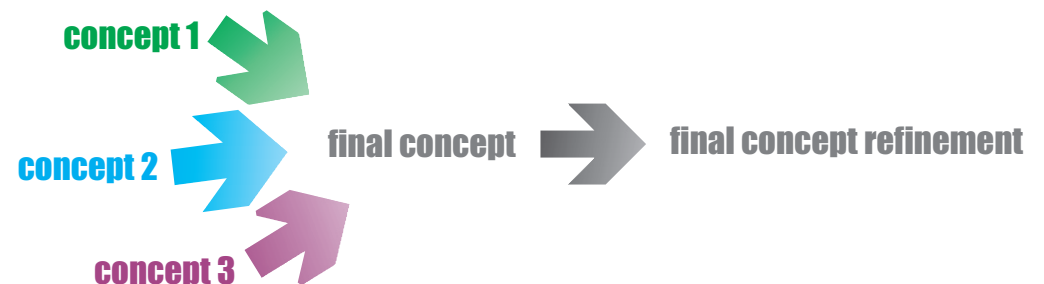

## Step 8: Final concept refinement

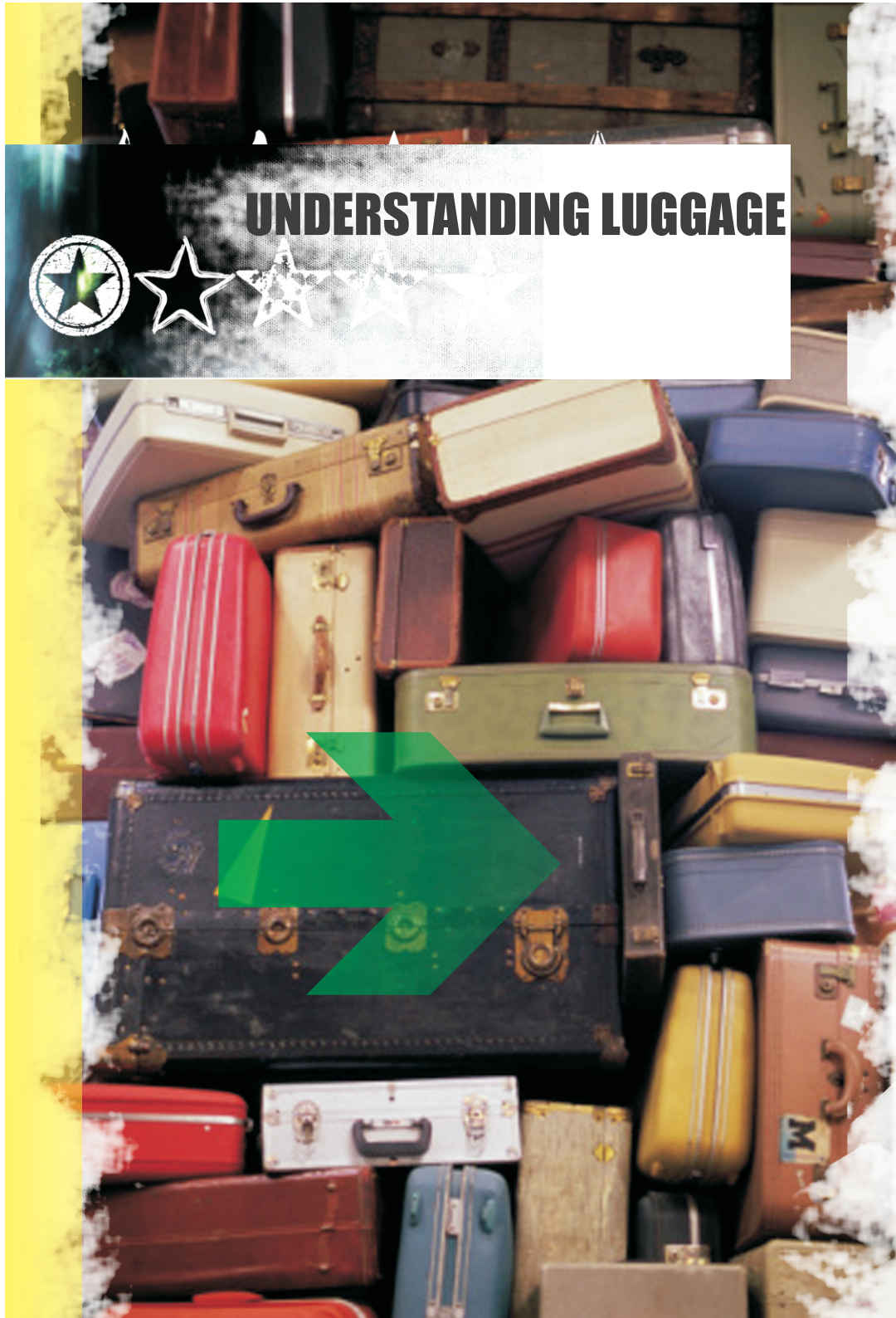

## UNDERSTANDING LUGGAGE

### *DATA COLLECTION*

1. Terminology
2. Types of luggage
3. Luggage accessories
4. Classification
5. Manufacturing & materials
6. Luggage & interaction

## 1. Terminology

the usual word for “baggage belonging to passengers

---

from lug "to drag"

“what has to be lugged about” or, “any thing of more bulk than value”

---

“baggage” is functionally related to the noun “bag,”  
and luggage related to the act of “lugging.”

Baggage can be synonymous with “luggage”,

---

Luggage is any number of bags, cases and containers  
which hold a traveler articles during transit.

---

luggage and the style thereof is representative of the owner's wealth.

---

Luggage is any number of bags, cases and containers which hold a traveler articles during transit.  
The modern traveler can be expected to have packages containing clothing, toiletries,  
small possessions, trip necessities, and on the return-trip, souvenirs.

For some, luggage and the style thereof is representative of the owner's wealth.

## 2. Different types of luggage



business cases



briefcase



cabin luggage



suitcase



backpack



air bags



laptop cases



messenger bag

### 3.Luggage accessories



travel document case



travel shoe pouch



multi organizer  
waist pouch



comfort neck pillow



carry on foldable



luggage security strap



anti-theft wallet



digital camera pouch



toiletry kit



travel safe wallet

## 4. Classification



**Hard luggage** is luggage manufactured by industrial process of injection molding or vacuum forming.

**Soft luggage** is the luggage which is stitched together using various soft materials.

**Hybrid luggage** is blend of hard & soft luggage, where soft material is stitched over hard skeleton or base. Some times bottom shell is hard and front shell is soft in hybrid type of luggage.

## 5.Manufacturing and materials

### Hard luggage manufacturing and materials

Polycarbonate and ABS shells are vacuum formed, PP shells are injection molded.

#### A. Injection molding

**Material** PP-Polypropelene  
lip to lip closing

Injection molded shells has lip to lip closing detail due to its dimensional accuracy stability.



#### B. Vacuum forming

vacuum formed shell has closing detail of either framed closing or zippered closing.

**Material** ABS  
framed luggage



**Material** PC  
zippered luggage



As Polycarbonate is strong impact resistant material low shell thickness is used hence the PC shells are stitch able hence zipper closing is used for PC luggage.

## Soft luggage manufacturing and materials



Soft luggage is the luggage which is stitched together using various soft materials such as polyester, EVA, nylon, neoprene, PVC. Soft luggage is stitched over molded EVA or formed PVC to get the hardness and the shape

### Hardware

Nylon, PP, PVC are used for manufacturing molded hardware for both hard & soft luggage.

## 6. Luggage & interaction

Luggage & accessories has become part of our daily life. Right from childhood to youth to professional or elderly stage of human life, there exist a human- luggage interaction.

Following **photo collages** give us hint about various types of interactions those take place



Luggage as a part of everyday life & various scenarios



Carrying luggage & various activities



Following **photo collages** give us hint about various types of interactions those take place



Luggage as a part of everyday life & various scenarios



Carrying luggage & various activities





### Luggage as a part of professional life

Business executives, managers, young professionals working in various fields carry luggage suitable to their lifestyle. At this part of professional life luggage and the style thereof is representative of the owner's wealth.



# Packing your luggage

Photo collage bellow represents most common type of human- luggage interaction that takes place during packing the luggage





## Emotions & luggage

### Luggage as a companion

Luggage we carry indirectly becomes companion during our journey. It helps us to get the feeling of having someone around or as a company.



### Luggage to rest over, sit & relax



### Luggage as footrest

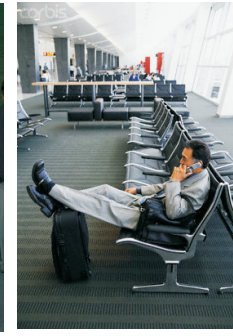

### Have u ever slept with luggage?





### Coolie`ing out with luggage



### On a car trip

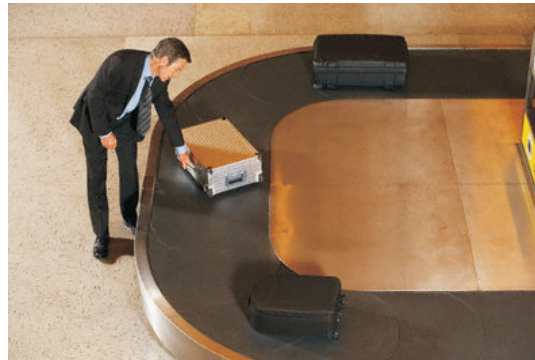

### At the airport belt

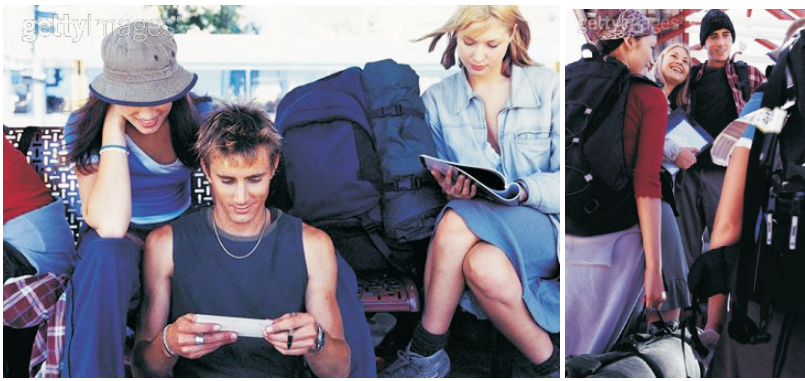

### Luggage & youth culture

Luggage one carries and the style thereof is representative of the owner's wealth attitude mindset and life-style.



### Luggage n` fashion





to grasp the idea of  
**objective statement**

To design  
an **UPRIGHT,**  
**HARD/ HYBRID**  
luggage using  
**POLYCARBONATE**  
as material and  
**VACUUM FORMING**  
as manufacturing process.

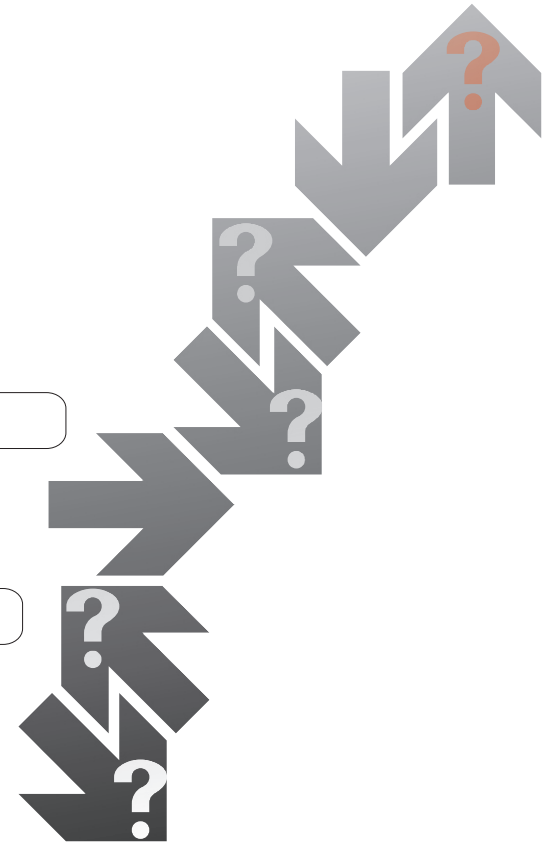

1. Appreciating the objective statement.



**HARD/ HYBRID**

To design an **UPRIGHT,**  
**HARD/ HYBRID**  
 luggage using  
**POLYCARBONATE**  
 as material and  
**VACUUM FORMING**  
 as manufacturing process.



**UPRIGHT**  
 vertical stance

**About POLYCARBONATE**

polymer with a unique blend of desirable properties

Polycarbonate sheets provide excellent value for money and perform effectively for years with minimum maintenance

various finishes, colours, textures possible

can be translucent or transparent

high impact resistance

light weight

expensive

**About VACUUM FORMING**

cost effective process for batch manufacturing

uniform thickness

rough edge details

less definition for the form

### Additional information

Other essential details those contribute towards better understanding of objective statement

About the luggage:

**unisex** version

not any particular location or culture specific

size 55cm cabin size or 65cm

**Journey:** 3-4 days of journey

Mode of transport:

By air or by higher class railways

## 2. Understanding the user

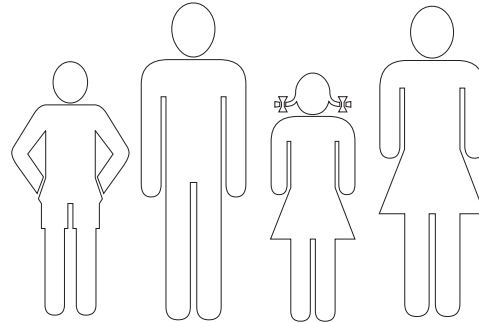

**sex:** male and/or female

**age:** 25 to 35 years

**Personality:**

- outgoing, smart
- passionate about traveling
- aware about current fashion, trends

User profession possibilities: user can be artist, designer, into creative work like advertising can be into marketing or can be post graduate student etc.

Financial status: middle class or upper middle class, uses his money smartly, opts for value for money products

## Understanding the user

How many days of travel?

**3-4 days approximately**

**what all he(considering)carries?**

Following are the list of things out of which a typical mentioned user will carry some, according to his area of interest or profession & life-style.

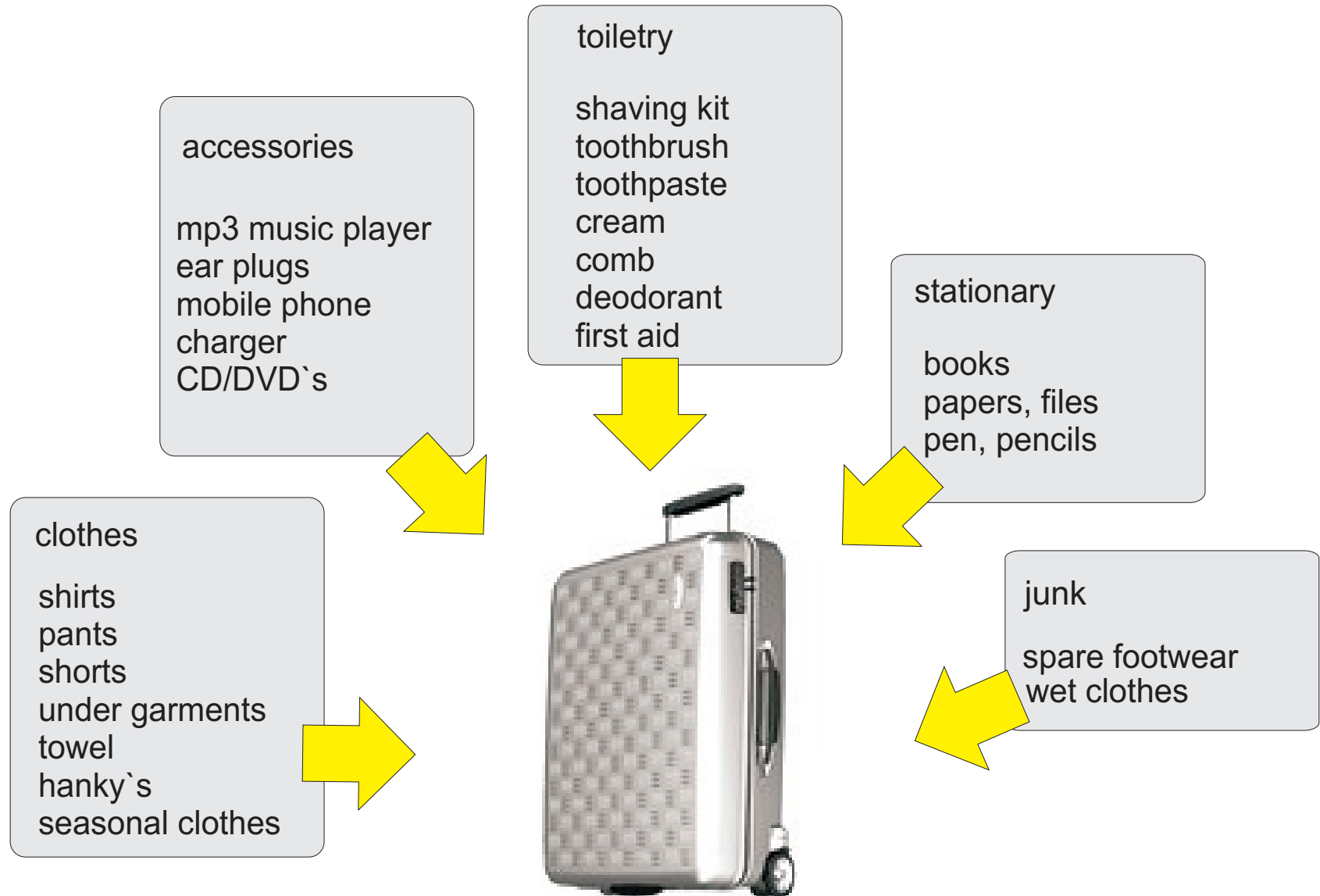

# Understanding the user

## clothes

- 2 shirts
- 3 t-shirts
- 3 pants
- 1 shorts
- 3 set of under garments
- 1 towel
- 1 napkin
- 4 hanky`s
- 2 pair of sock

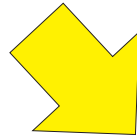

## accessories

- shades
- mp3 music player
- mobile phone
- charger
- CD/DVD`s
- digital camera, cables
- spare batteries

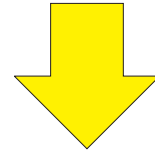

## stationary

- 1 books to read
- 1 sketchbook A4 size spiral
- 1 notebook or diary
- stationary pouch: pen, pencils

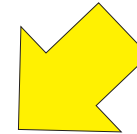

## toiletry

- shaving kit
- toothbrush
- toothpaste
- cream
- comb
- deodorant
- first aid

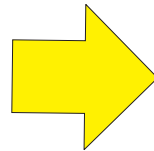

## junk

- spare footwear: chappals

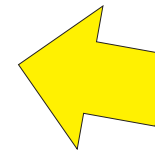

## *ANALYSIS & IDEATION*

1. Upright stance & form
2. Upright colours
3. Upright texture & finish
4. Upright sizes
5. Upright components
6. Trolley
7. Wheels
8. Lug
9. Handle
10. Lock
11. Interiors
12. Pullers
13. Hybrid variation
14. Visualizing bag as a whole

## 1. UPRIGHT STANCE & FORM



### Scope / Insight

Form of the upright should visually convince the user, customer that there is big space inside to keep maximum luggage at the same time it should not make it look like heavy or bulky. So there has to be equilibrium regarding these factors.

Hybrid upright luggage to be designed can have nu`age stance that portrays, on the ground rooted character at the same time form can be such that it makes it dynamic & youthful. Simple details like grooves, chamfered profiles will be interesting to try out.

## 2. UPRIGHT COLOURS



### Observation / Analysis

Dark colours shows off dust, dull colours shows off scratches.

### Scope / Insight

Hybrid luggage will certainly give scope to experiment ,tryout colour combinations.  
Bottom shell which will is more prone to rest on ground can have darker shade as compared to front shell. Bottom shell can be manufactured in fixed dark shade and front shell colours can be varied to get different combinations and to save the cost.

### 3. UPRIGHT TEXTURE & FINISH

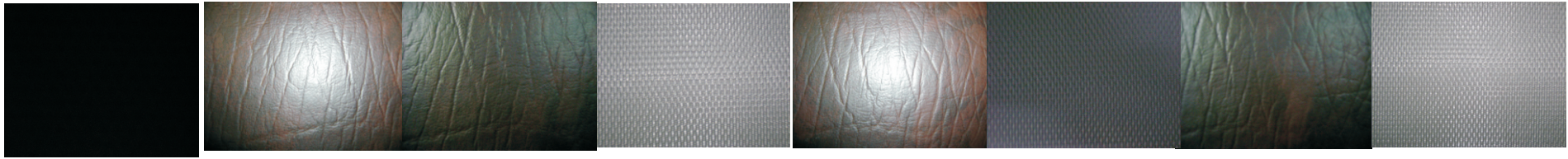

#### Observation / Analysis

Glossy, mirror finished luggage stands out and is preferred sometimes but it shows off dust and scratches. Matte finish is used in most of the luggage so as to make it more convenient to maintain.

#### Scope / Insight

Textures adds to the visual appearance of the luggage also makes it strong

Hybrid design has scope where one can have matte finish for the back shell as it rests on the ground while packing, the front shell can have combination finish or texture variation.

Polycarbonate has very wide range of textures and finish possibilities using it judiciously will enhance the visual appeal of the luggage.

## 4. UPRIGHT SIZES



55      65      75<sub>cms</sub>



55<sub>cms</sub>



### Observation / Analysis

Generally you get similar design of the luggage in various sizes 55cm, 65cm, 75cm, air-bag size 55 cm is referred to as cabin size luggage as that is the maximum allowable height for the luggage one can carry and fits in the cabin storage during air travel.

### Scope / Insight

While designing hybrid upright luggage its convenient to consider cabin size as preliminary size to start with. after successfully designing cabin size upright similar design considerations will be adopted for various other sizes

One more interesting point for cost reduction is, same hardware is used for different sizes of the same design. So handle size will be same (same handle will be used) for 55cm bag and 65 cm bag.

## 5. UPRIGHT COMPONENTS

lock



trolley



lugs



closing & opening details framed



lock

trolley



side handle



lock



wheels

side handle



lugs

wheel



### Scope / Insight

Its not mandatory to have all of these components, a smart design might reduce need for one of these components this will further reduce overall cost.

# 6. TROLLEY

## Observation / Analysis

### Interaction



Gives option of mounting axillary luggage on the bag resting on the trolley stem



Makes it very easy to carry heavy luggage



No space given around the trolley handle to make it easy comfortable grab



From the top view you can see two lifting handles

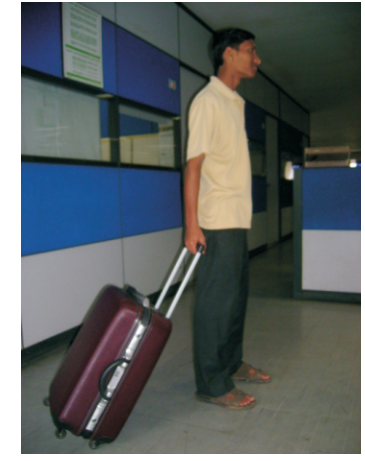

User needs to change wrist position and hand orientation during the whole interaction of pulling out or pushing down the trolley

TROLLEY

Observation / Analysis



single stem trolley



double stem trolley



if trolley is outside the bag there are chances of it getting damaged due to mishandling



trolley makes luggage heavy



various sizes



mechanism



interior of the bag look uneven due to trolley inside this makes problem for packing the luggage occupies inside volume of the bag

Scope / Insight  
Ideation sketches



single stem trolley

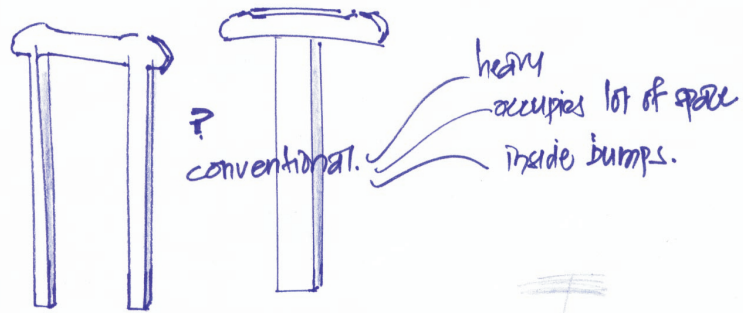

string trolley

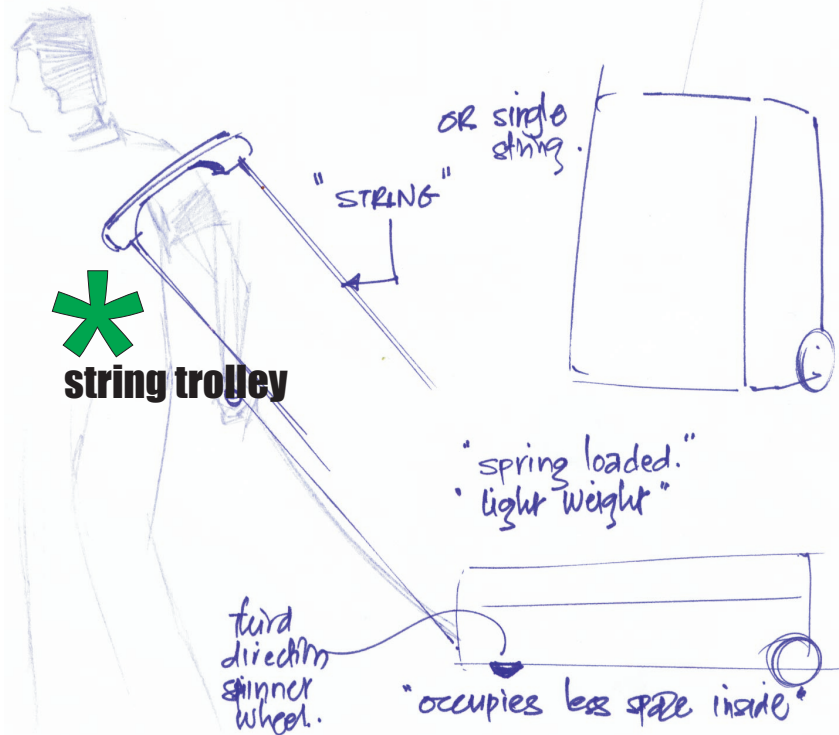

trolley that rotates to open up

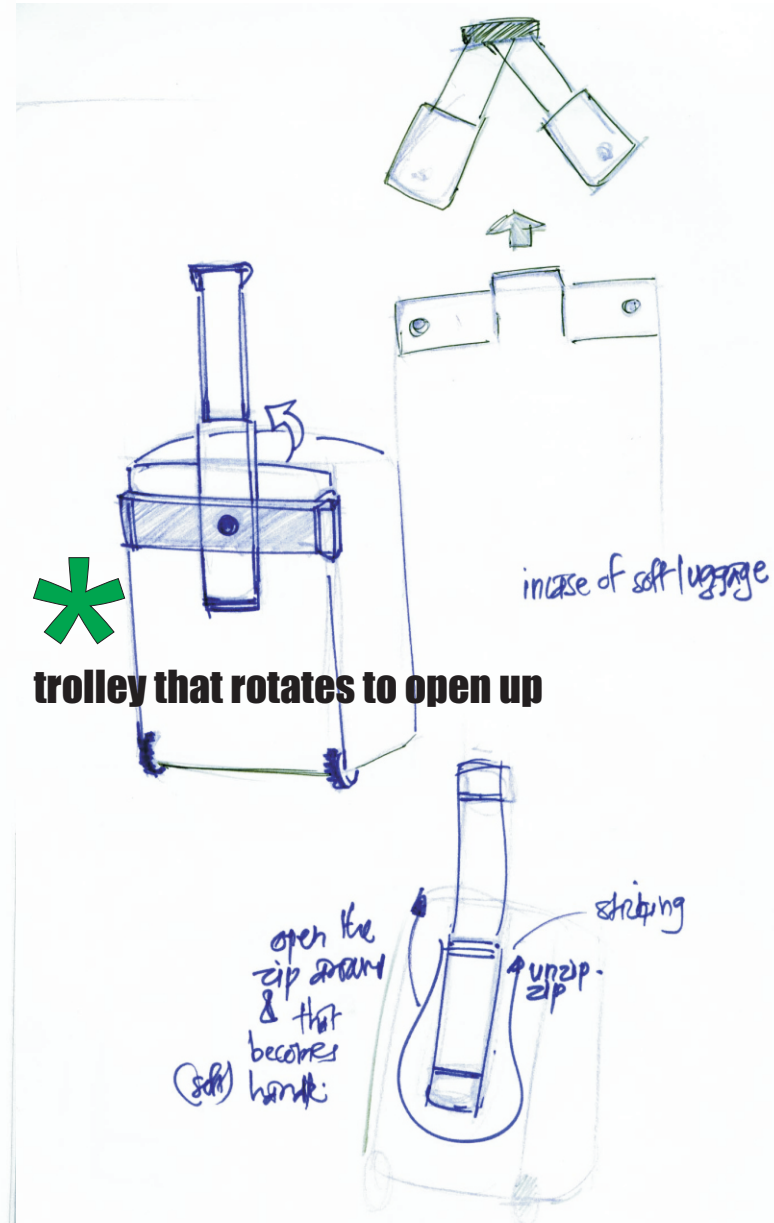

Ideation sketches

collapsible — needs rail space  
delicate

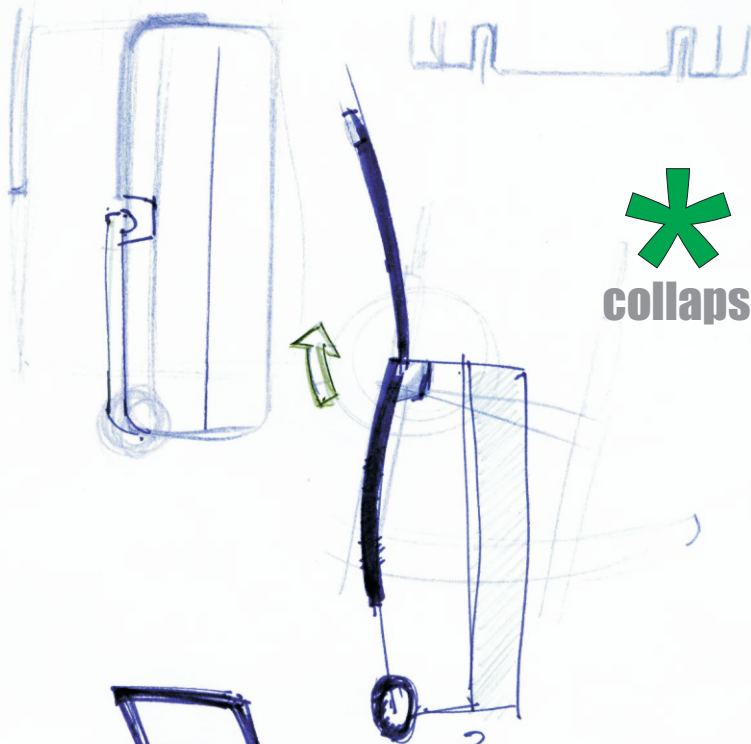

**collapsible trolley**

? anyway occupies space for depression

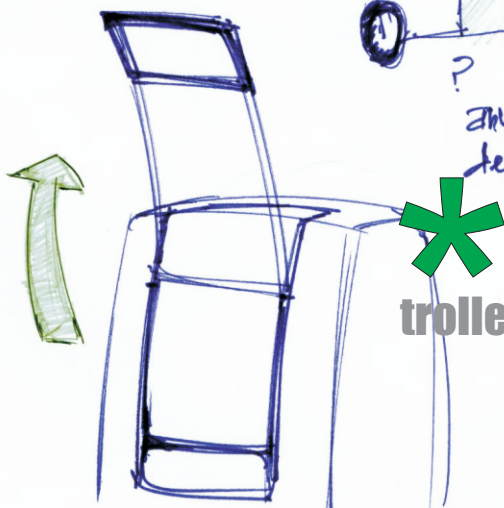

**trolley that opens out over the hinge**

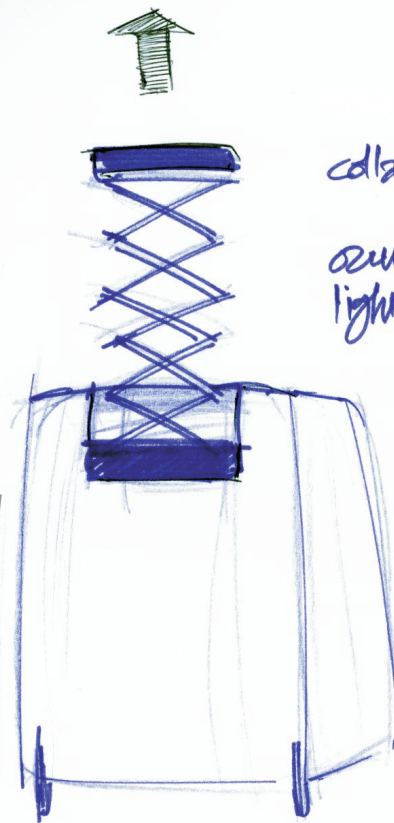

collapsible links

occupies less space,  
lighter w/o trolley

may might add visual element  
to bag if treated nicely  
useful for fashion range  
1 minor



occupies very  
less space.





trolley projecting out of the surface yet fitted from inside

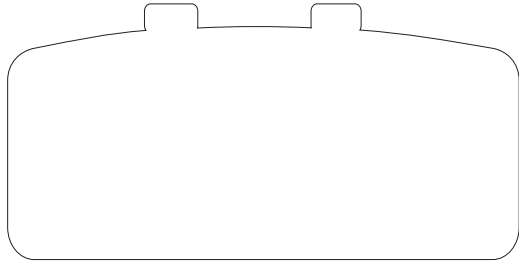

trolley integrated with top handle

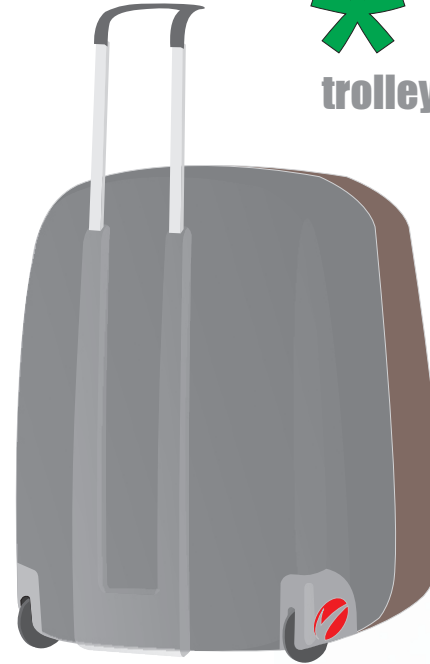

trolley with different objectives

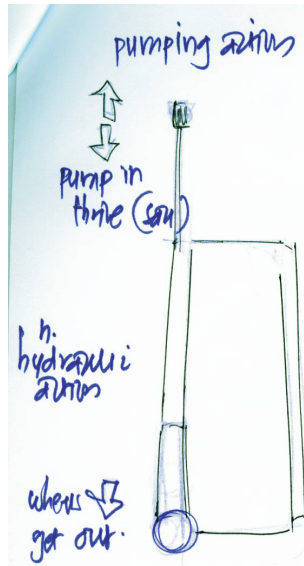

through screws complicated easy + sophisticatedly possible

how!! how to get back inside press the button, release air through valve...



trolley integrated with other functional possibilities

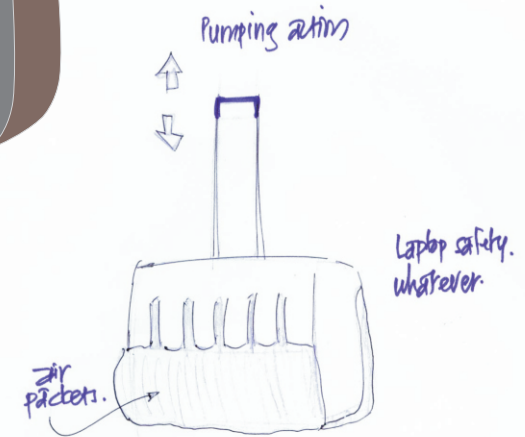

imagine : bubble packaging



such with fir bags. u can have even one safety bubbled belt over impact probable area.

it might give some different feel or act looks.



trolley+ wheels+back console

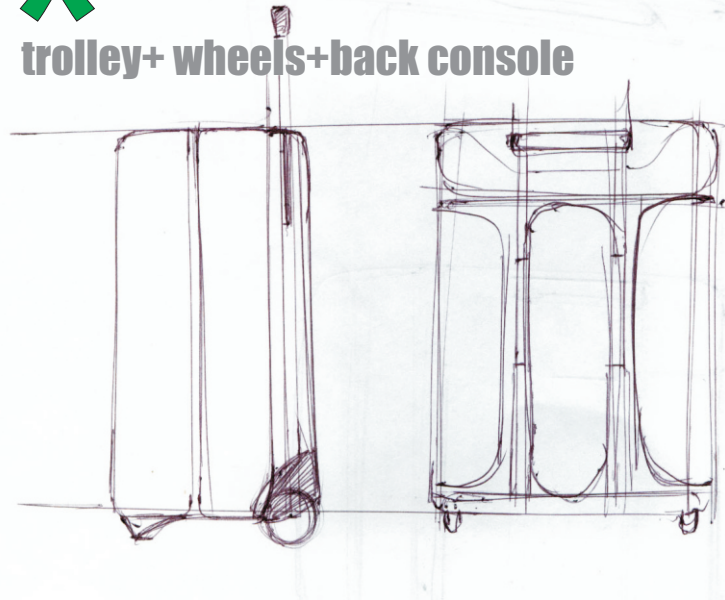

trolley with different mechanism



v- frame trolley

regular botkey

press

projecting catch to hold if air pressure. thank!!  
magnet here will reduce or chuck out whole mechanism. so that it stays at the position.

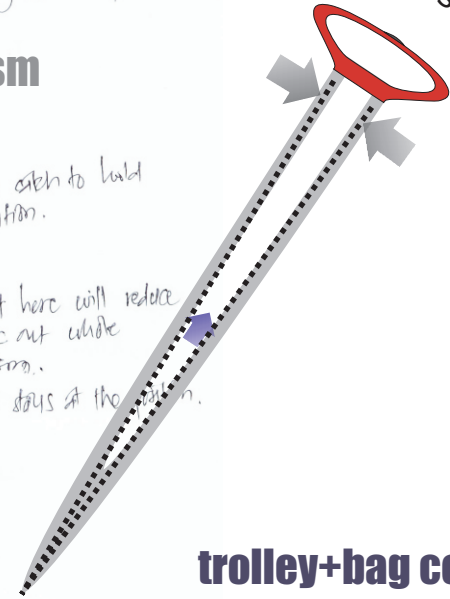

trolley + small detachable bag



trolley+bag cover

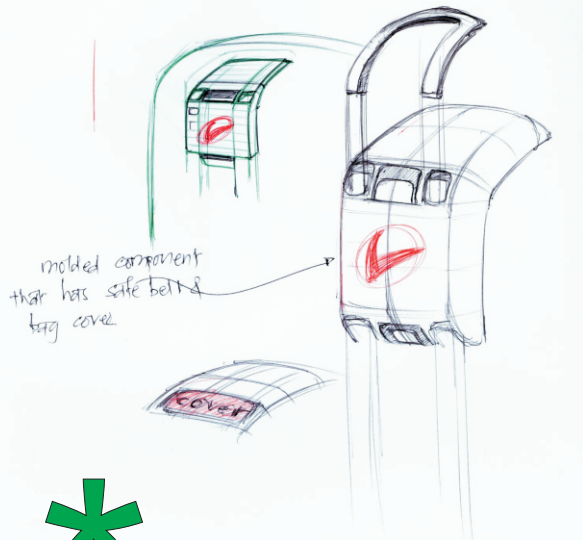

trolley integrated with other functional possibilities

trolley + safety belt

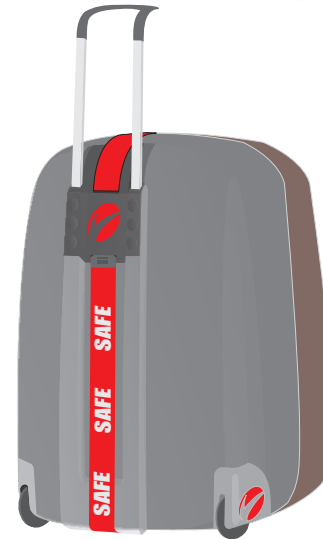

## 7. WHEELS

### Observation / Analysis



### Observation / Analysis

Normally wheel diameter for hard luggage is 9cm or even more than that.

Canopy or socket that holds the wheel together with bag consumes additional space

Wheels occupy space inside the corners

Wheels projecting out of the profile of the bag has possibility of getting knocked off or they get damaged

Wheels add to the total weight of the luggage hence they should be light weight, slick but sturdy enough to

Sustain large weight and volume

### Scope / Insight

Wheels should be noiseless and smooth

Most of the uprights have two wheels but some designs do have four wheels, these designs have two wheels on the front Which can rotate 360 degrees.

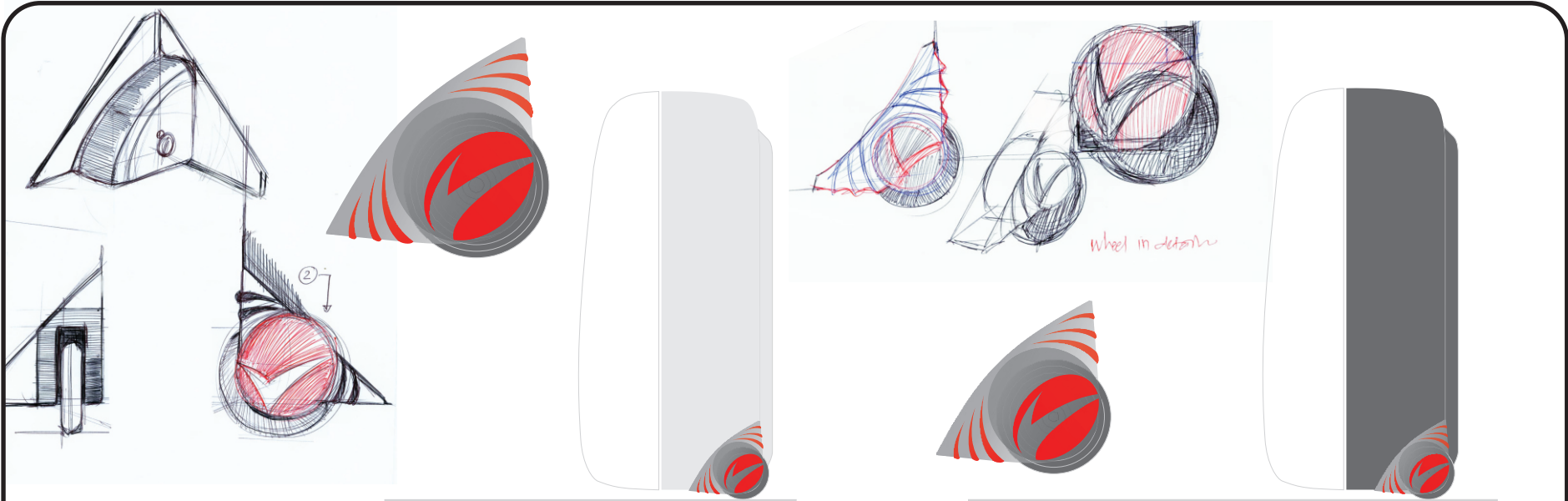

**\* branding on wheels**



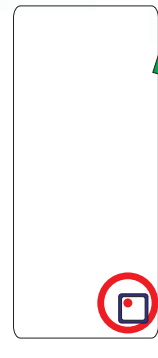
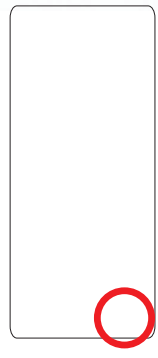
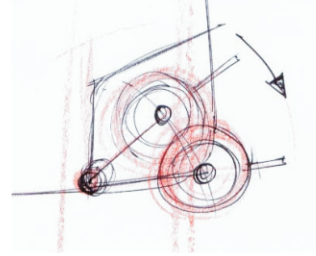
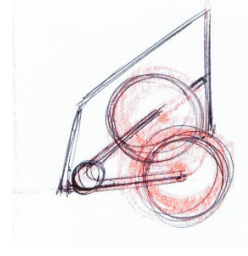
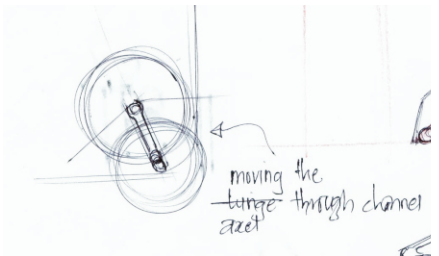
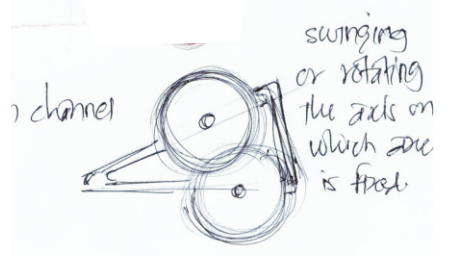

**projecting out wheels**

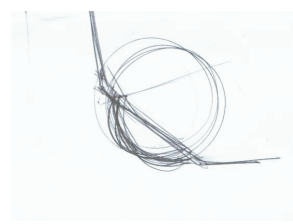
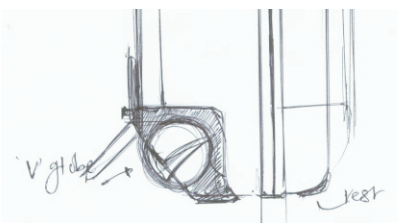
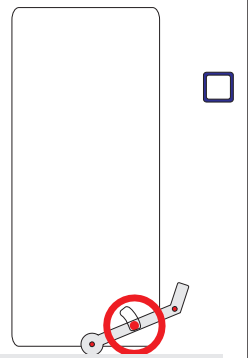
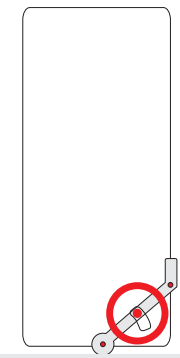
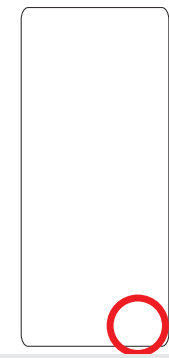

**functional when inclined type of wheels**

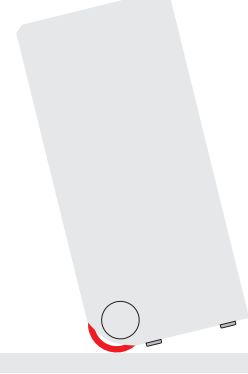
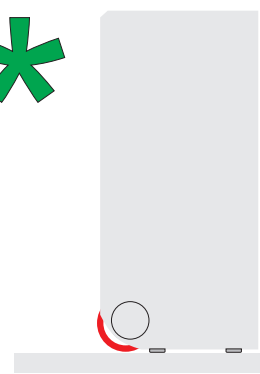

**flip open wheels**

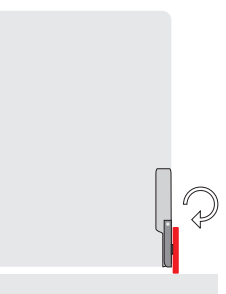
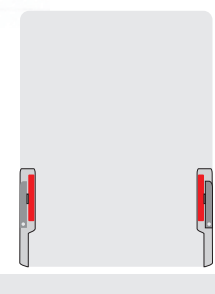
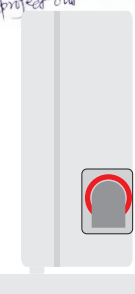
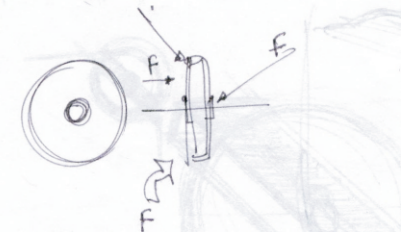
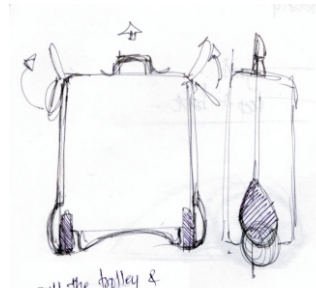

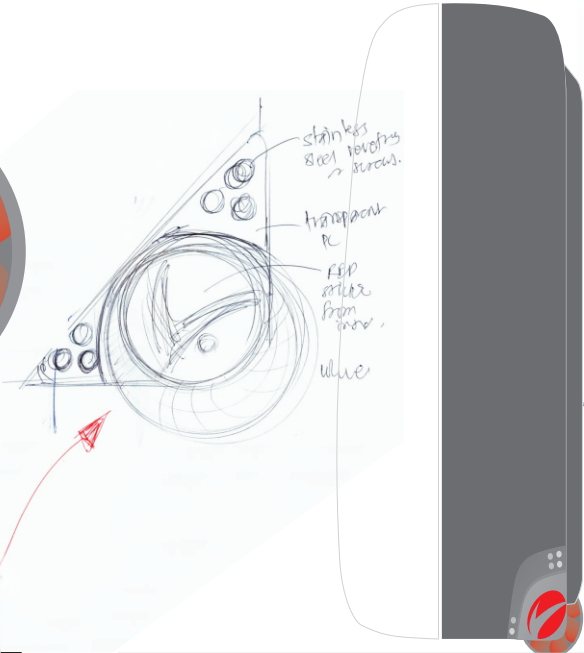
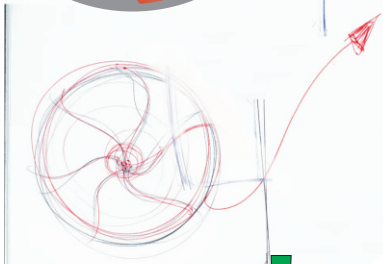
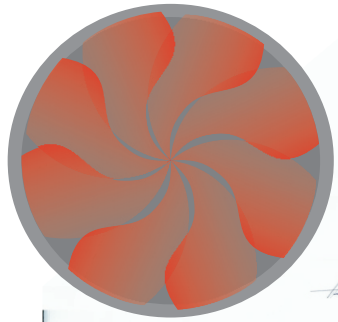

**\* transparent wheels**

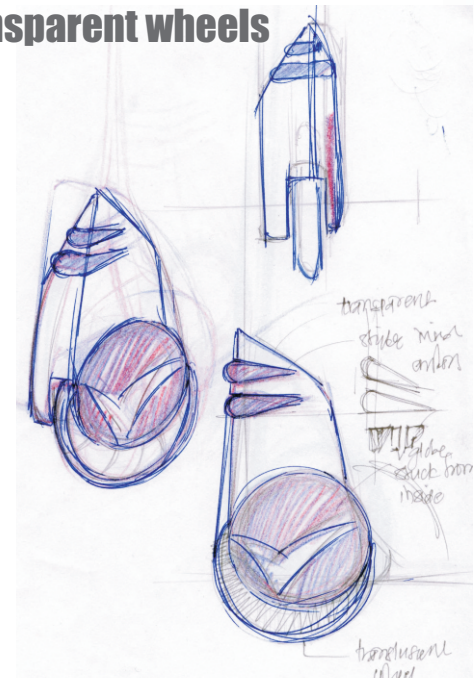
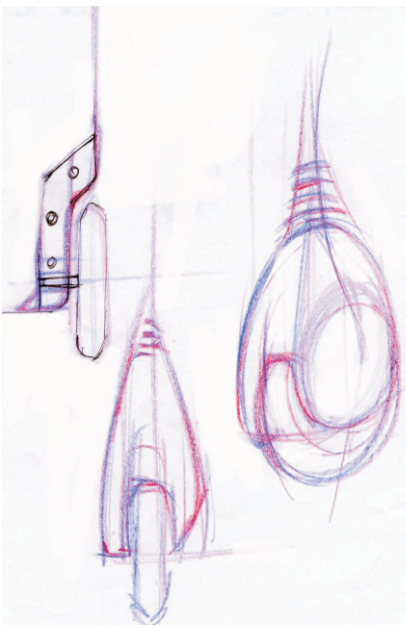

**\* wheels integrated with lugs**

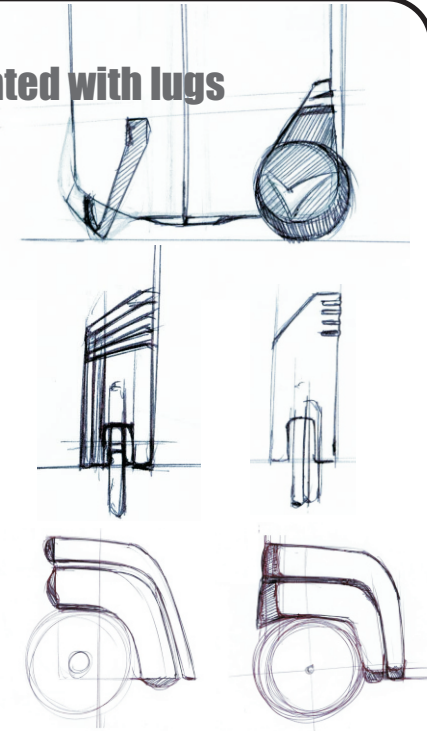
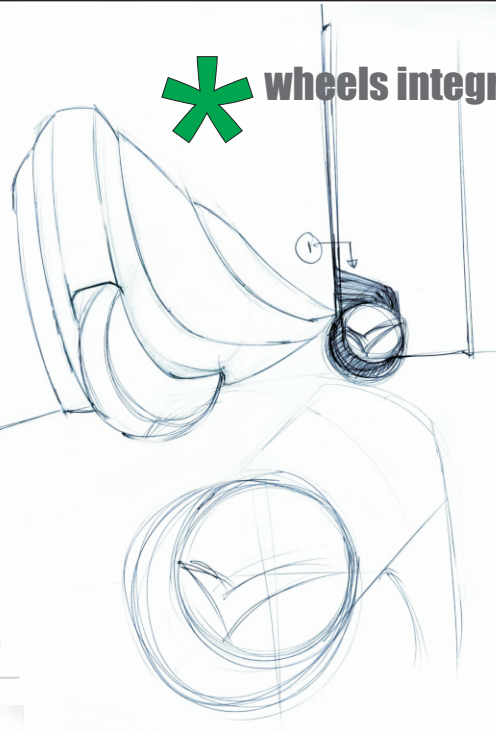

**\* noiseless wheels**

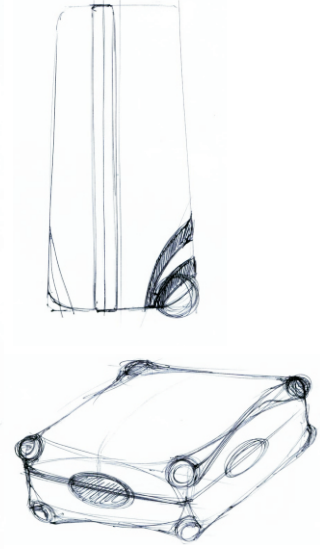
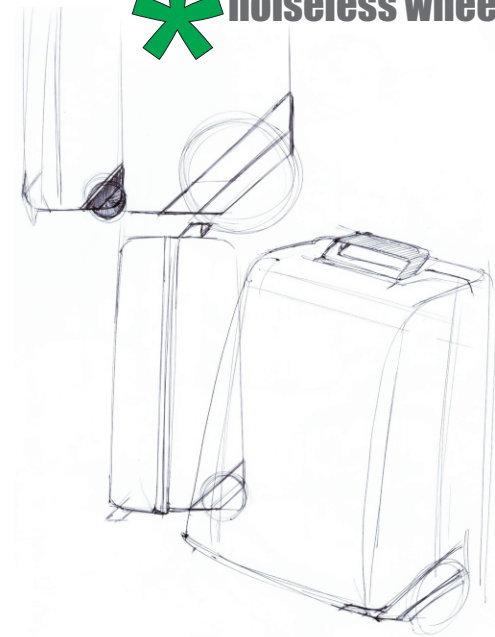

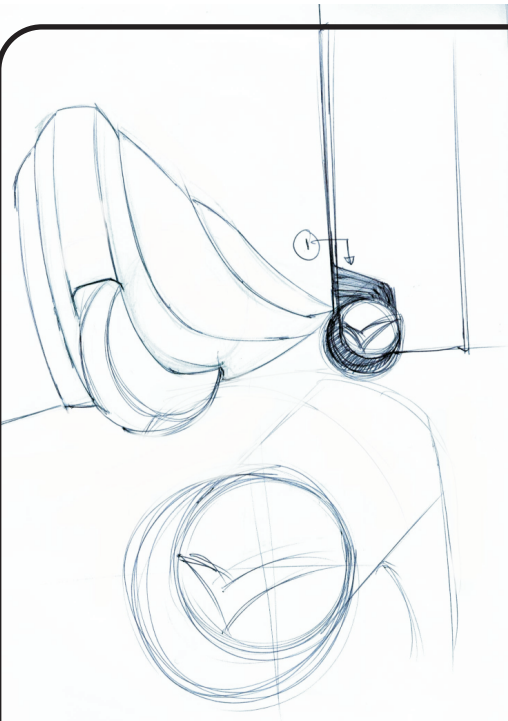

\* wheels integrated with lugs

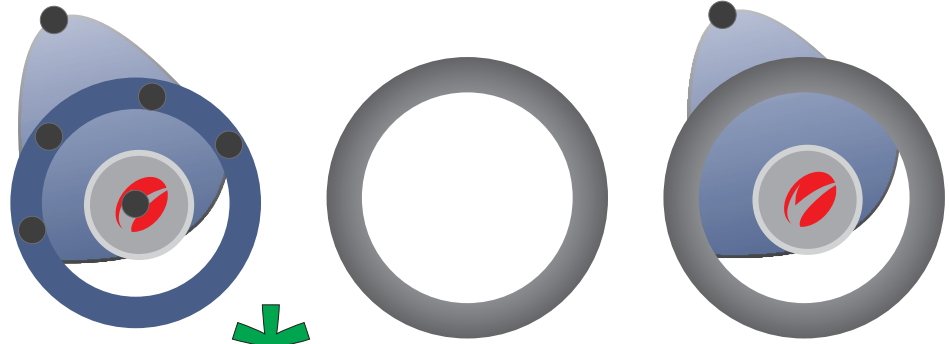
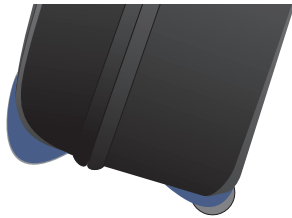
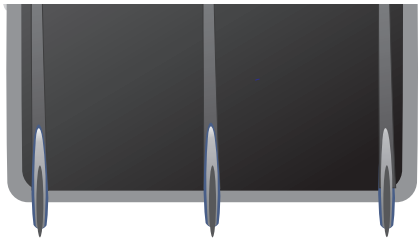

\*  
hubless wheels



\*  
ball and socket wheels  
360 degree wheel

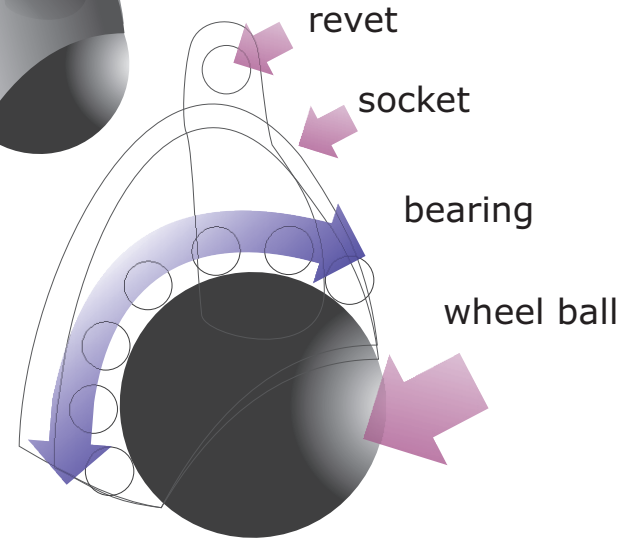

# 8. LUGS

Observation / Analysis

Scope / Insight

Ideation sketches

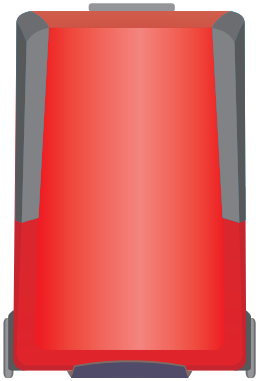

\* single lug at the centre

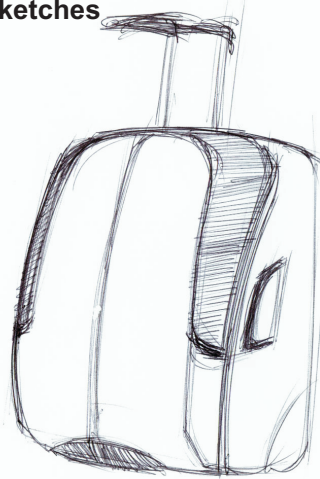

\* metallic lug

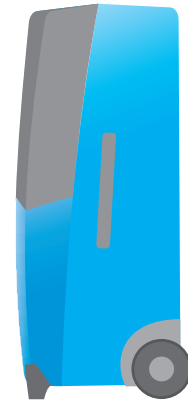

## LUGS

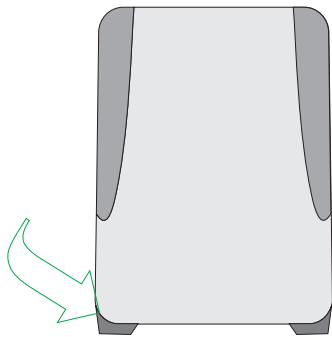

one or two number of lugs depending on the style/design

styling blends with the main styling of the bag

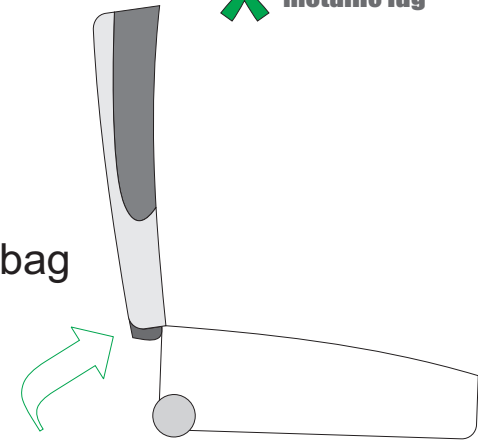

lugs will rest on the bottom shell wall when bag is opened this will keep front shell of the bag vertical in open position.

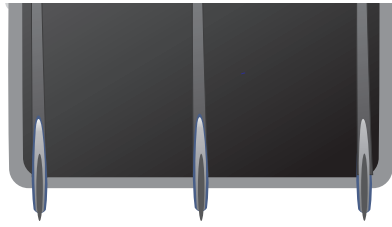

\* three lugs

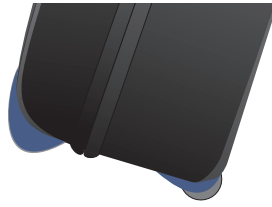

\* lug integrated with wheel

lugs will be hollow hence they will help during lifting the bag to keep into the cabin



GRAVA  
GRAVITY IS LAW. OBEY IT



\* loop lug

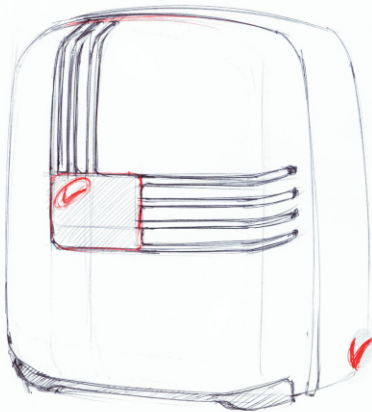

\* metallic lug

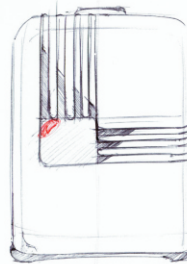

metal or nylon lug fitted with rivet

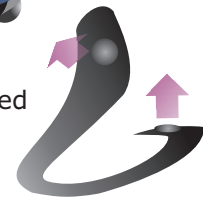

## 9. HANDLE

### Observation / Analysis

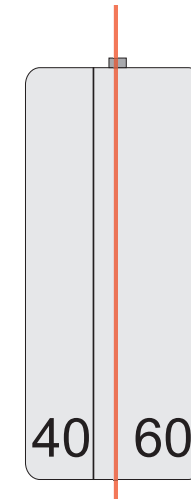

Side handle is also provided to an upright as lifting upright entirely with the top handle is not convenient as with side handle.

Infact top handle is very rarely used and hence some of the uprights even don't have top handle

Side handle is used to lift the luggage and put it over cabin or carrier

Side handle is useful to lift the luggage when one has to walk the stairs or at places where luggage can't be rolled over wheels.

Makes luggage asymmetrical with handle on one side and lugs on the other side

Position of the handle to make it comfortable lifting of the luggage  
centre of gravity and the lifting point should be colinear.

If handle projects out of the surface the chances of getting it damaged.

To avoid this retractable handle are used which slides out when you hold them

\* top handle integrated with trolley handle \*

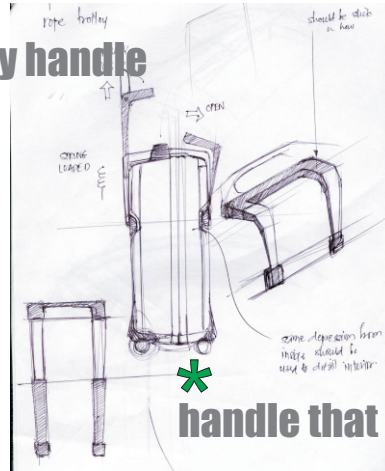
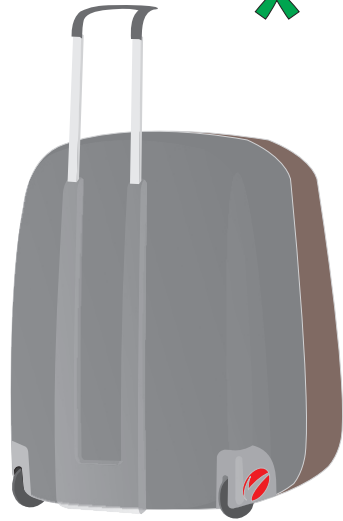

\* handle that lifts luggage as

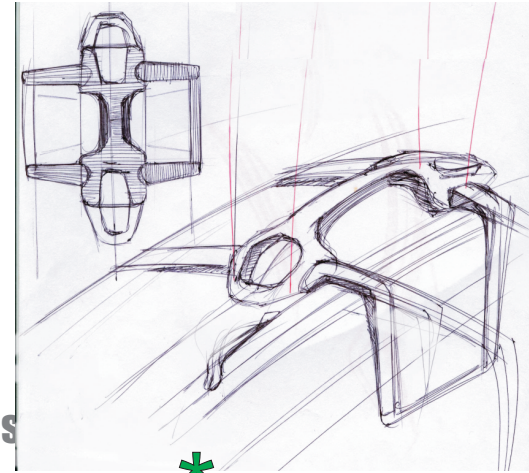

\* handle + locking

\* loop handle

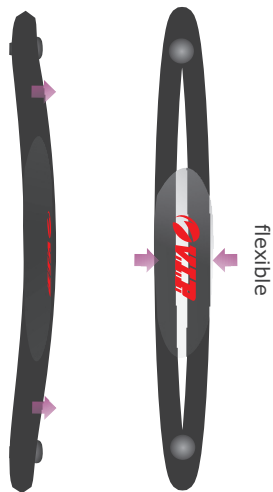

\* retractable handle with different mechanism

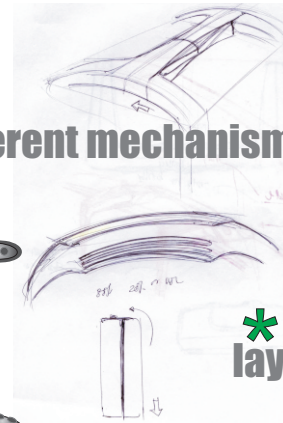
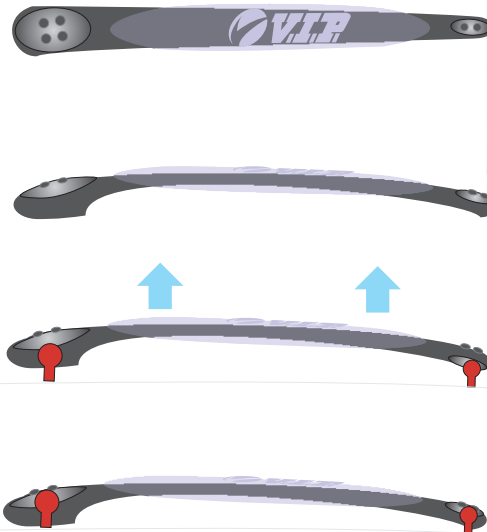

\* layered handle

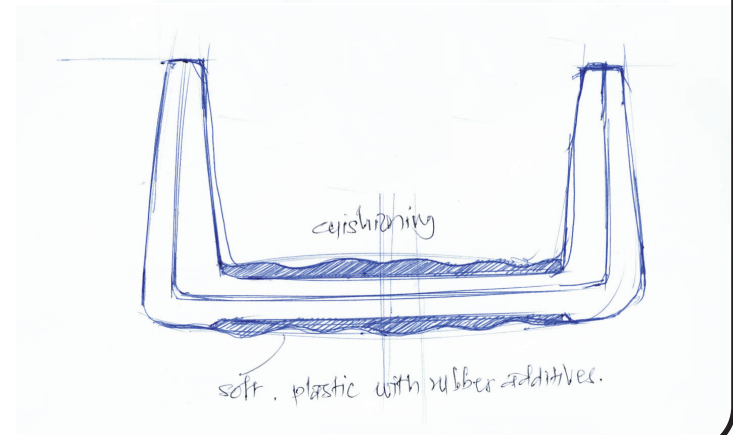

### Hinge

#### Observation / Analysis

upright luggage has hinge on one of it sides

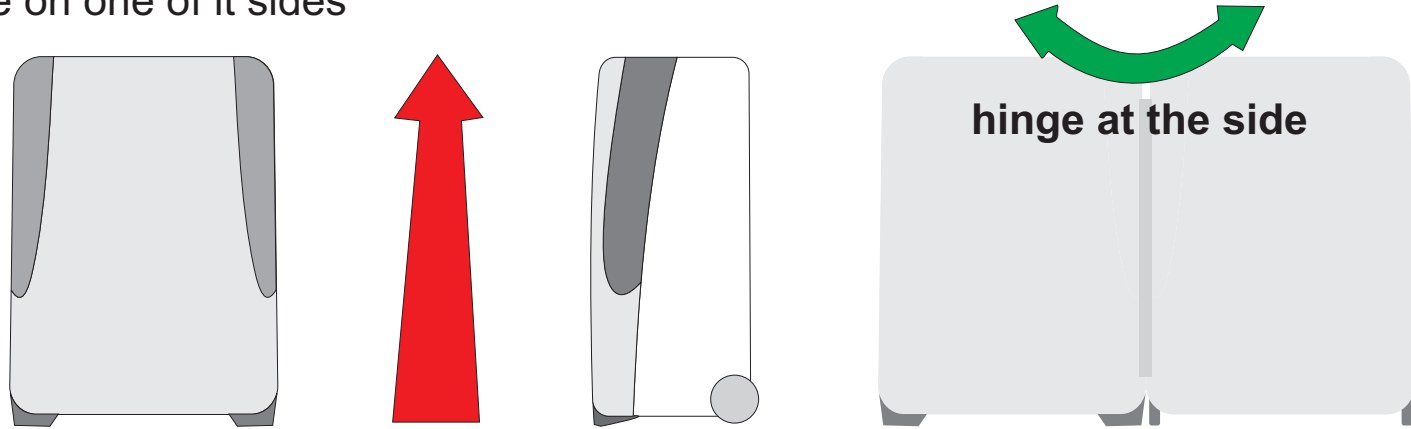

upright luggage has book opening where it entirely opens like a book and rests over ground

#### Scope / Insight

#### Ideation sketches

there is a possibility where upright luggage has hinge at the bottom

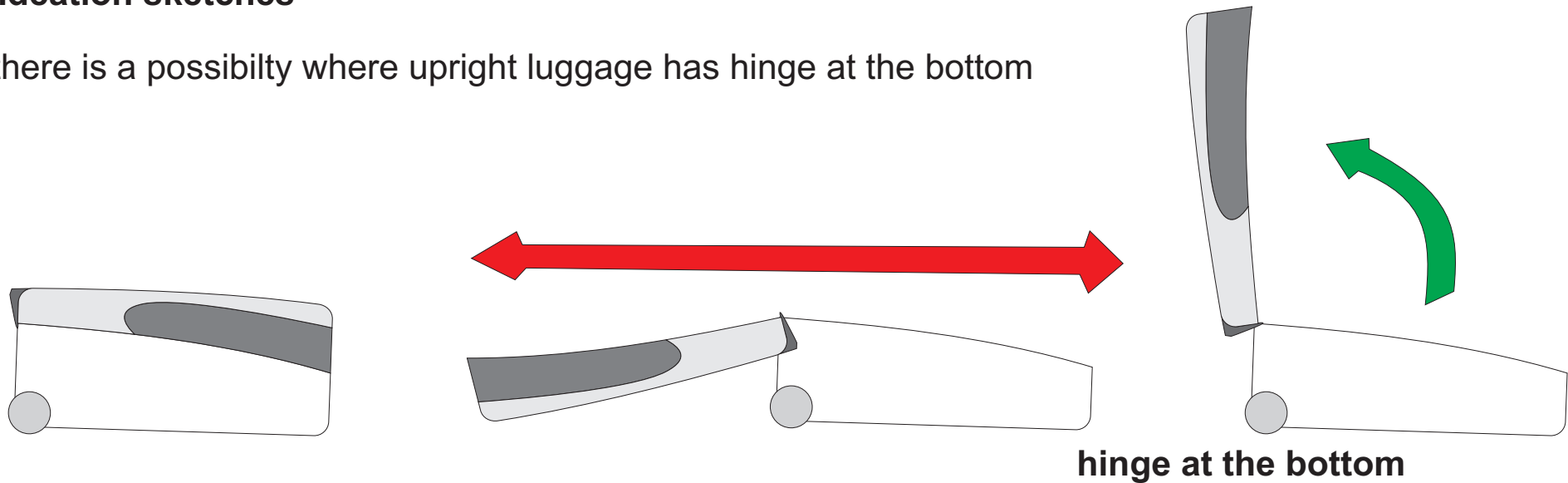

10. LOCK

Scope / Insight  
Ideation sketches

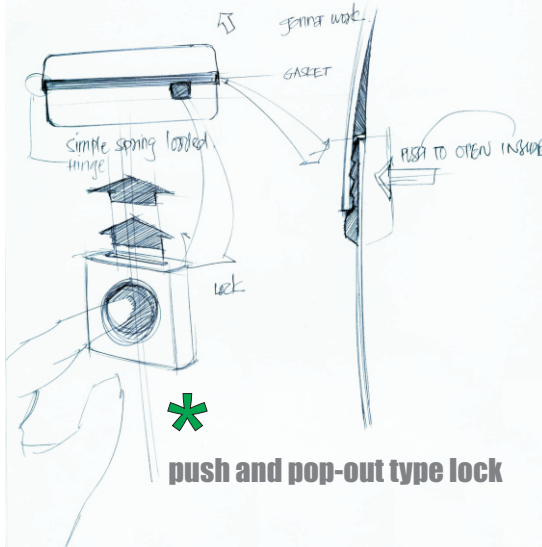

\* push and pop-out type lock

\*  
circular ring lock

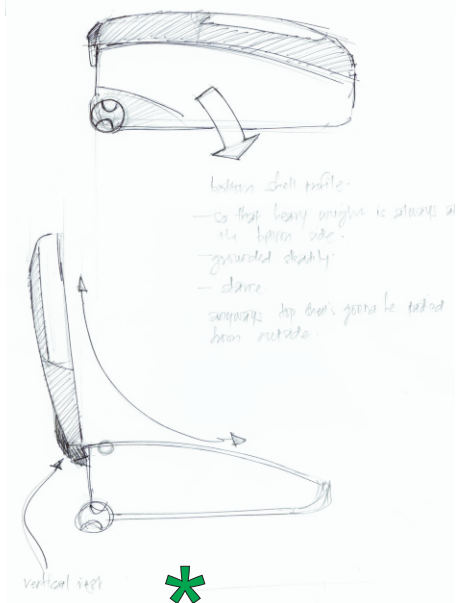
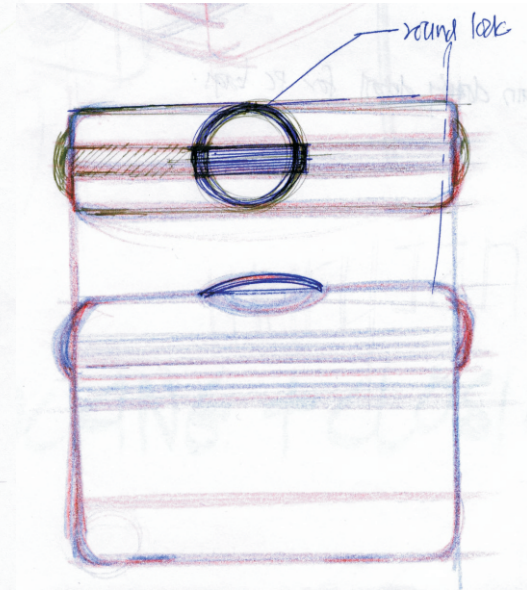
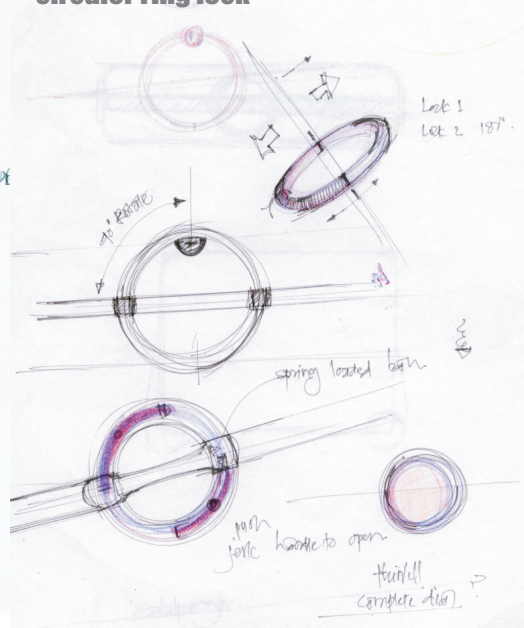

\* circular TSA lock

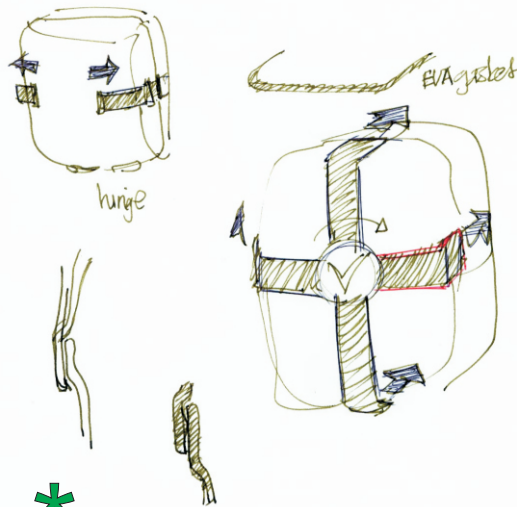

\* quadrant lock

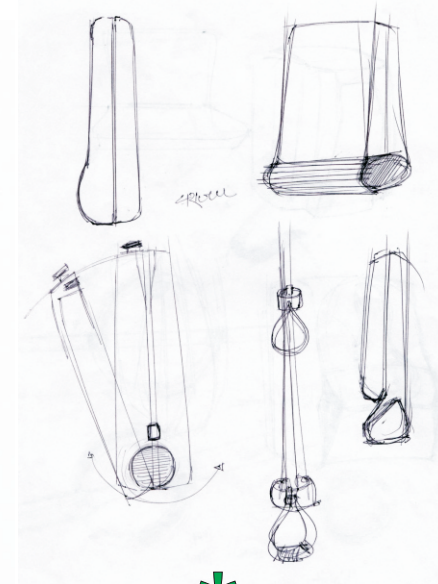

\* slide over lock

11. INTERIORS

Observation / Analysis



Interiors are one of the most important factors of the luggage design. Interiors should be as simple as possible so that it lets the user pack maximum stuff efficiently and systematically.

Scope / Insight

Ideation sketches

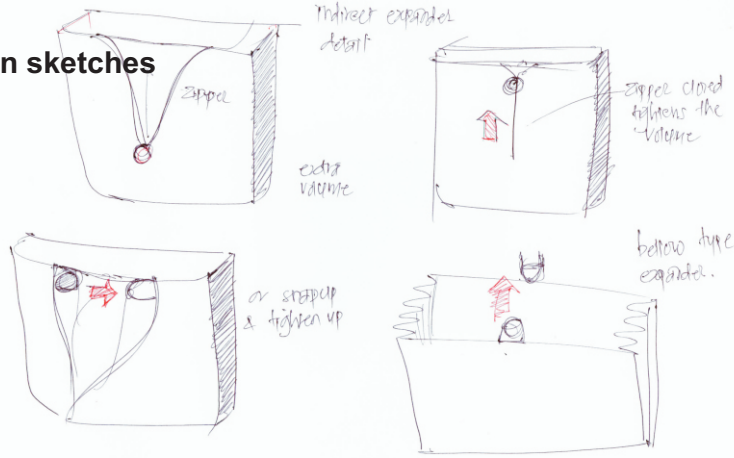

\* expander detail

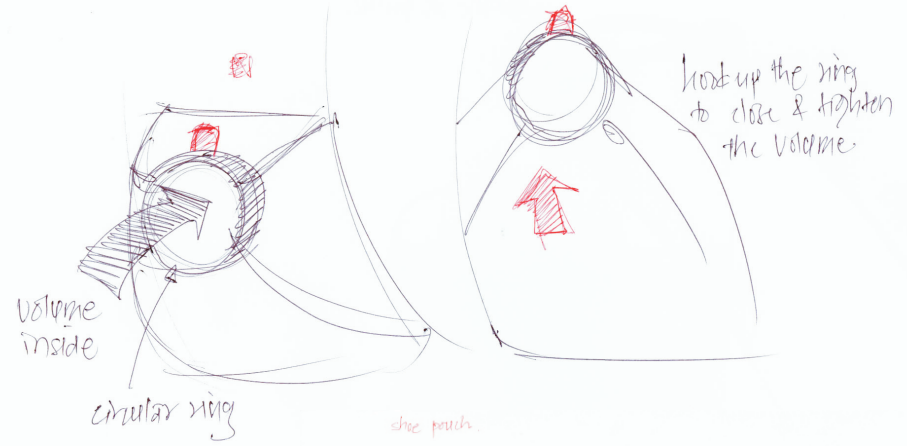

\* junk bag

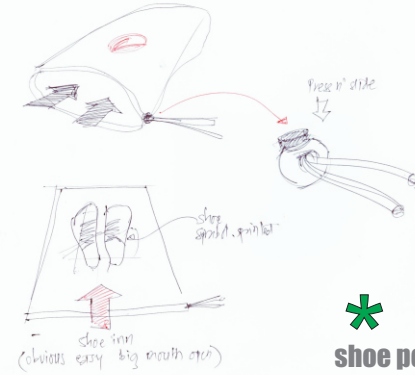

\* shoe pouch

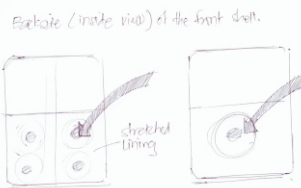

\* interior detail

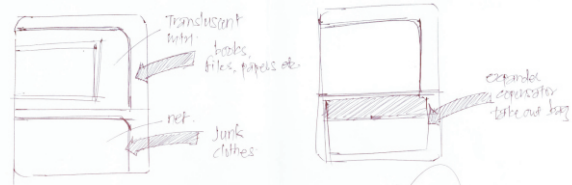

\* interior detail



\* toiletry pouch

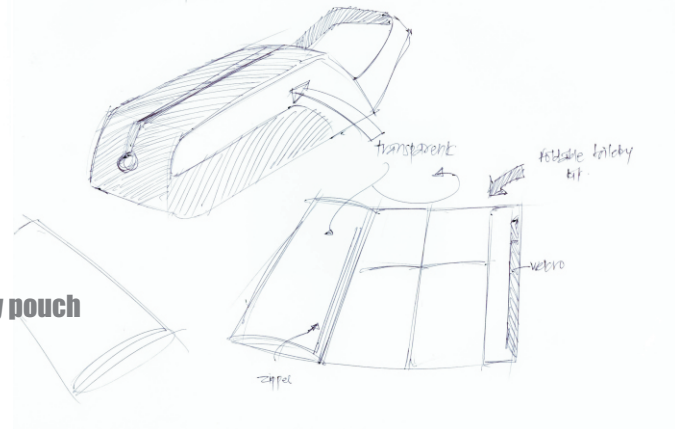

Bag is packed in horizontal position & carried in vertical. so clothes inside fry and slide over each other.

Vertical divider can solve this issue!

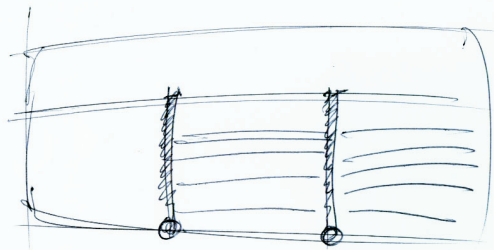

attached to the trolley stems.

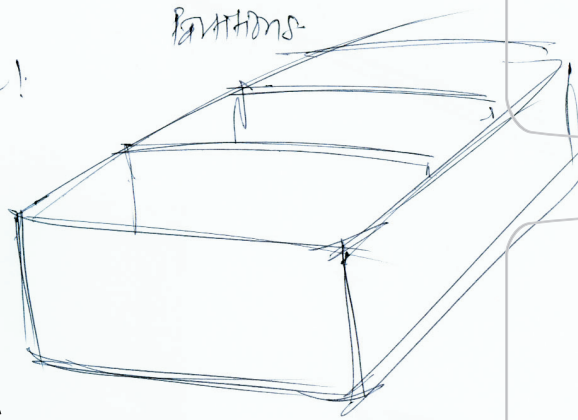

\*  
compartment

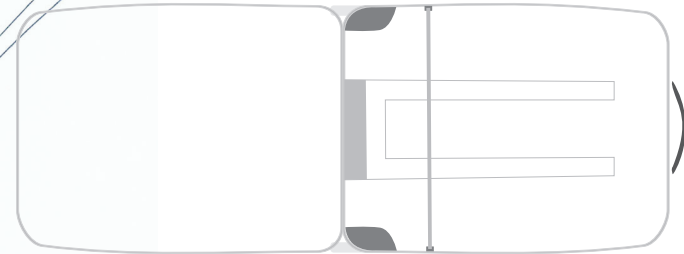
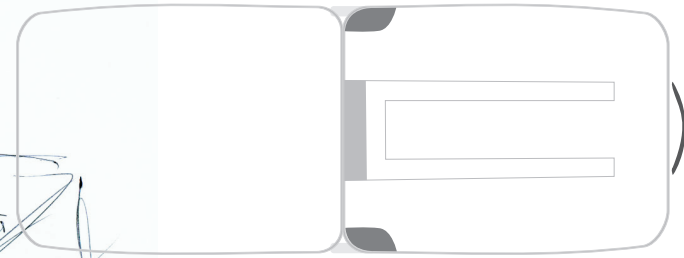

\*  
packing aid

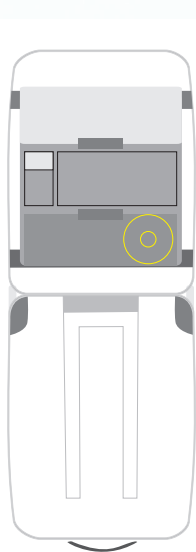

\*

expander compensator take away bag

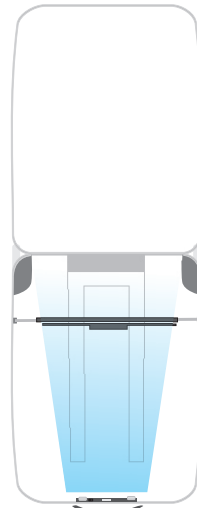
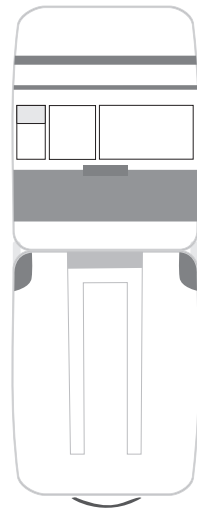

\*

LED light inside bag

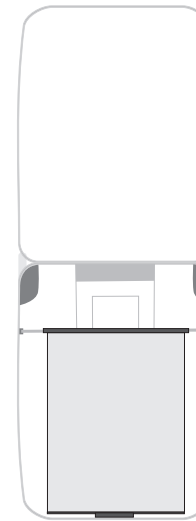
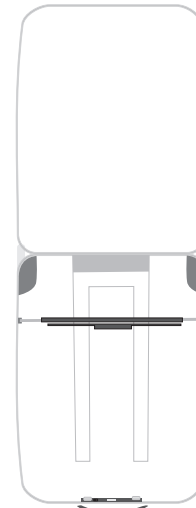

\*

Layered packaging aid

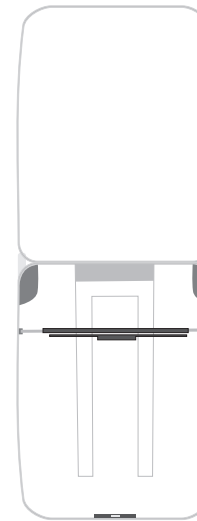

12. PULLERS

Scope / Insight  
Ideation sketches

**\* INTERLOCKING PULLERS**

pullers

zip

puller

puller lock, lock.

Puller 1.

Puller 2

two pullers meet & lock with each other.

magnetic tips in the puller make them stick together & hence inhibiting zipper noise.

**\* PULLER REST**

concept III - Bag with the hybrid front shell.

motive: allows user to access necessary stuff during the journey without the need for actually opening the bag.

puller rest here safely when zip is closed

zipper rest detail.

zipper opening:

dimensions: 40cms x 50cms

zipper rest detail.

zipper rest detail.

zipper rest detail.

**\* ANGLED PULLER**

pullers

TSANGLED PULLER

YELLOW ARROWS

**\* BIGGER SIZE ERGONOMIC PULLER**

puller

even bigger puller in size can be operated using palm grip which is much more comfortable than finger grip (helps others, specially).

Gives easy grip or strength to move puller easily.

TSA lock: hybrid front shell allows TSA lock to be on soft part that blends with the profile.

metal box.

press to open

number 10

bigger sized puller fits the reach till TSA lock.

Scope / Insight  
Ideation sketches

\* REVERSE TROUSER PULLERS

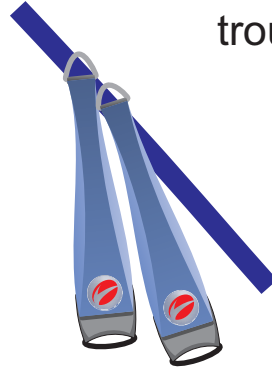

trouser pullers that has flip-up and lock feature

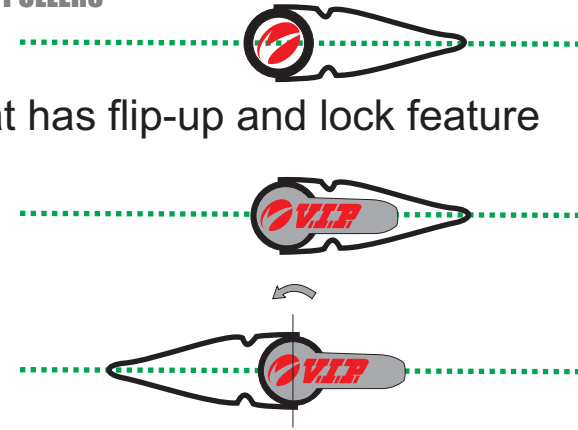

pressing the loop puller while opening the zipper makes it more comfortable and smoother operation

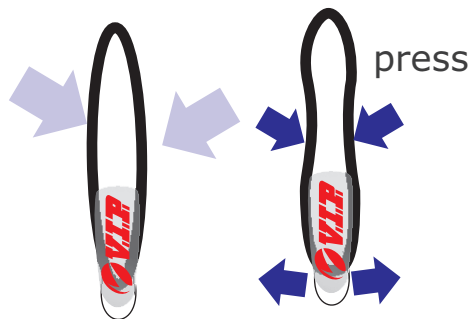

increases the tolerance and frees runner to travel over zipper

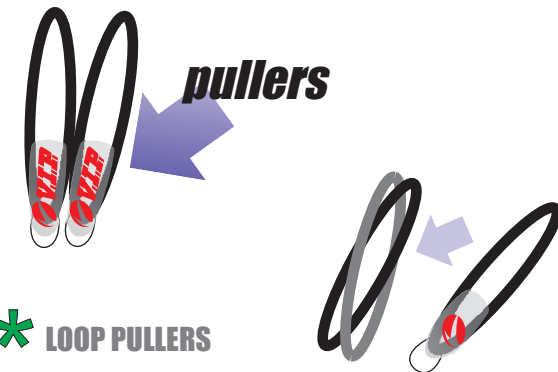

\* LOOP PULLERS

puller get entangled so they don't make irritating noise

### 13. HYBRID FRONT SHELL VARIATION

variations possible in the hybrid front shell according to the utilization of the shell volume and the access to it.

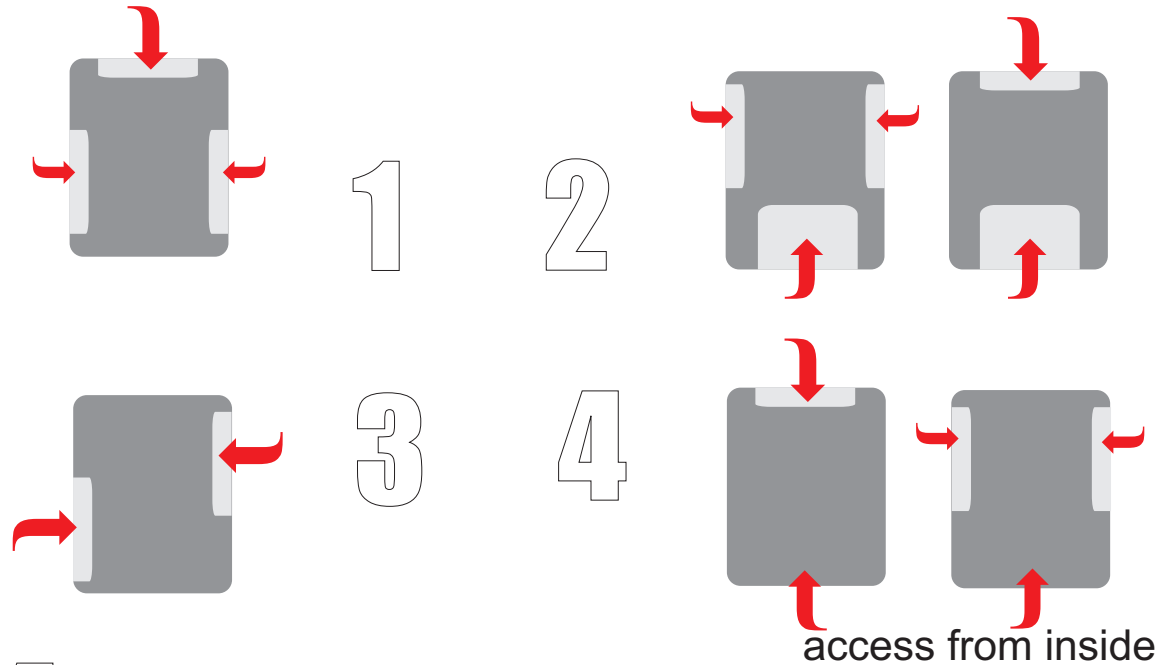

4 option 4 variations are tried out & actually made in a shell

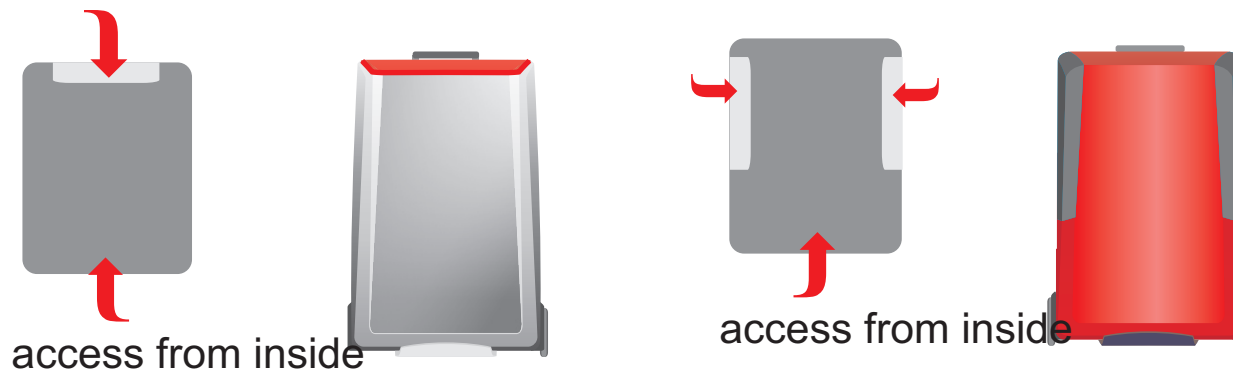

14. VISUALIZING BAG AS A WHOLE

*VISUALIZING BAG AS A WHOLE*

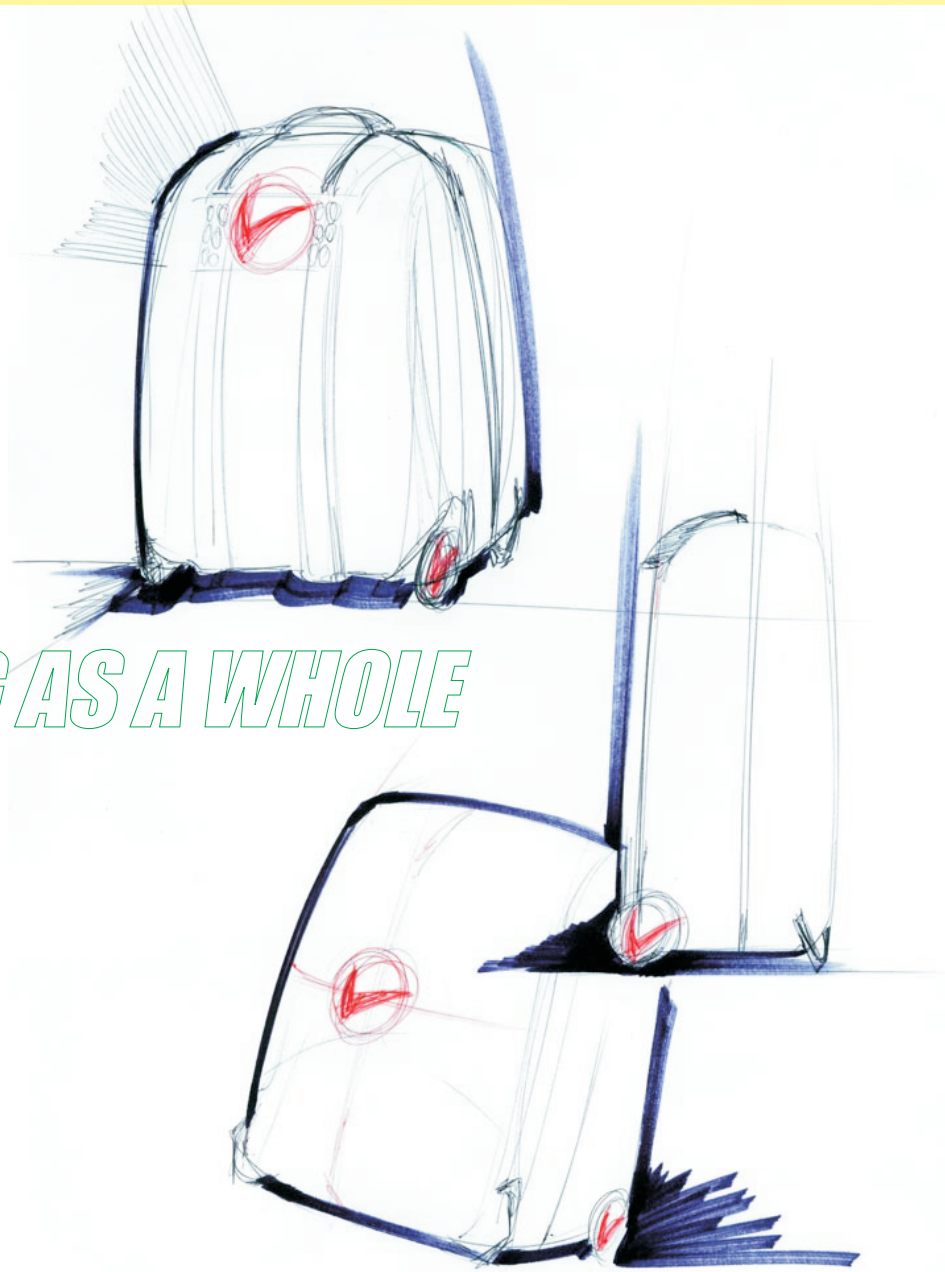

VISUALIZING BAG AS A WHOLE



GRAVA  
GRAVITY IS LAW. OBEY IT

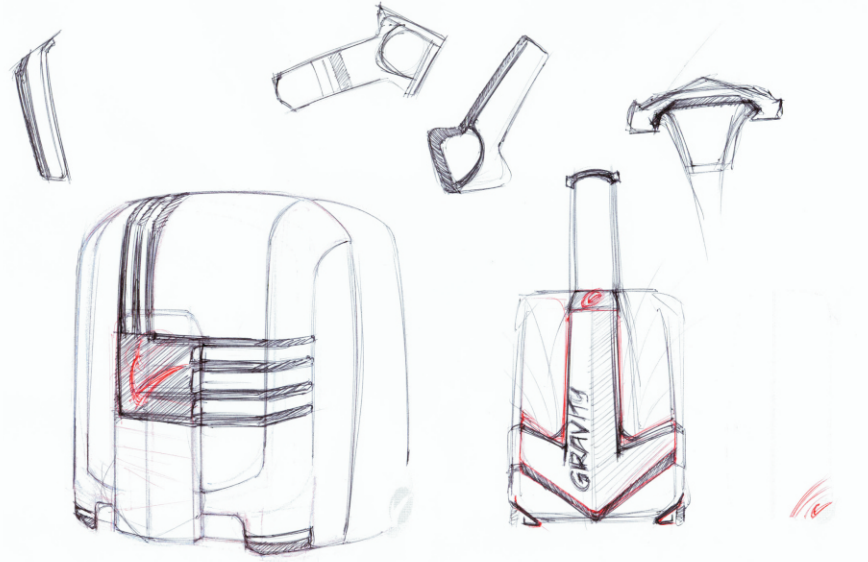

savor

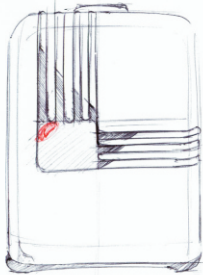
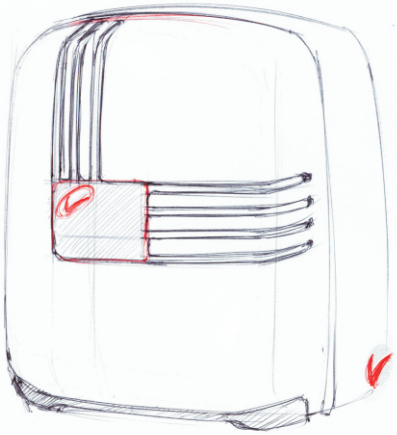

viola viola



VISUALIZING BAG AS A WHOLE



ANALYSIS & IDEATION

VISUALIZING BAG AS A WHOLE

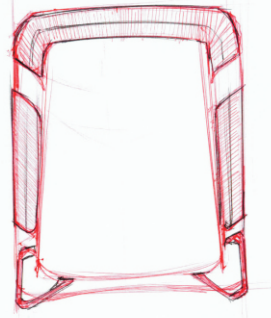
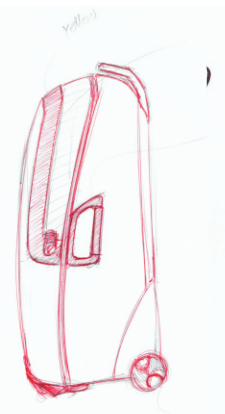
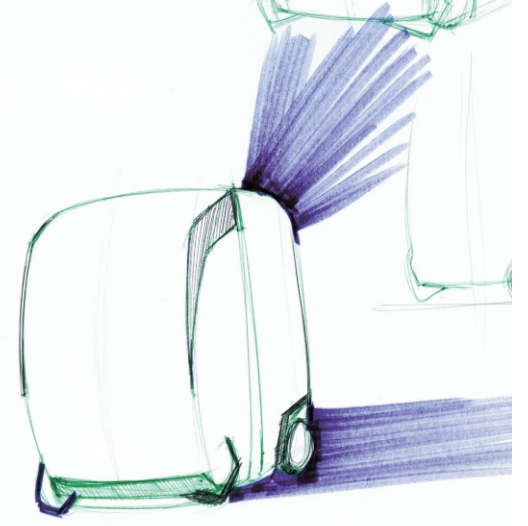
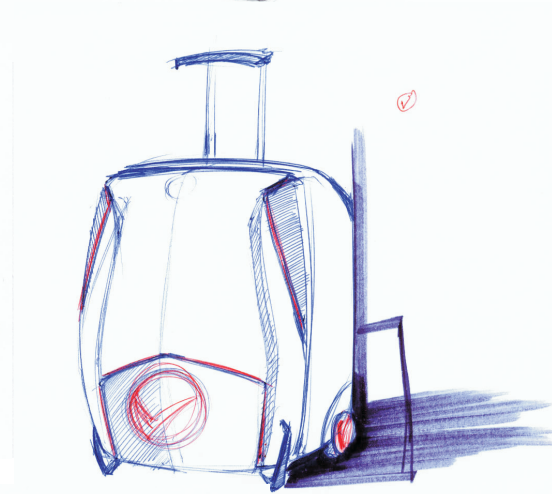
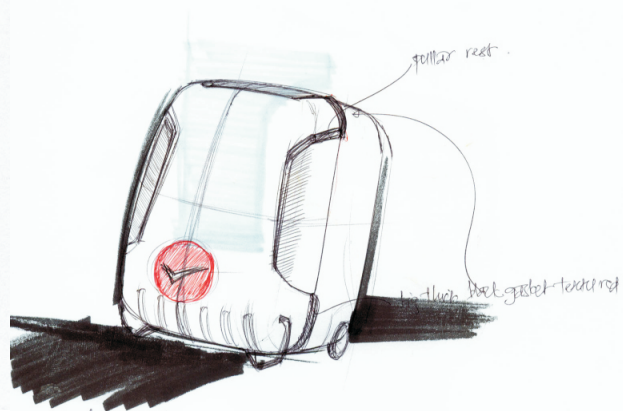
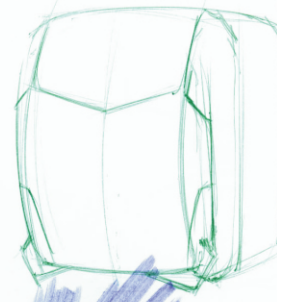
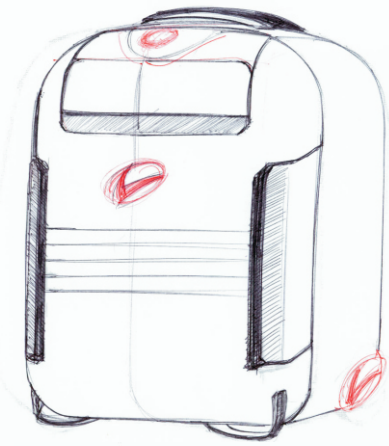

two handles of both sides:  
left side as handle + side lug.

rollbar  
elaborate

VISUALIZING BAG AS A WHOLE

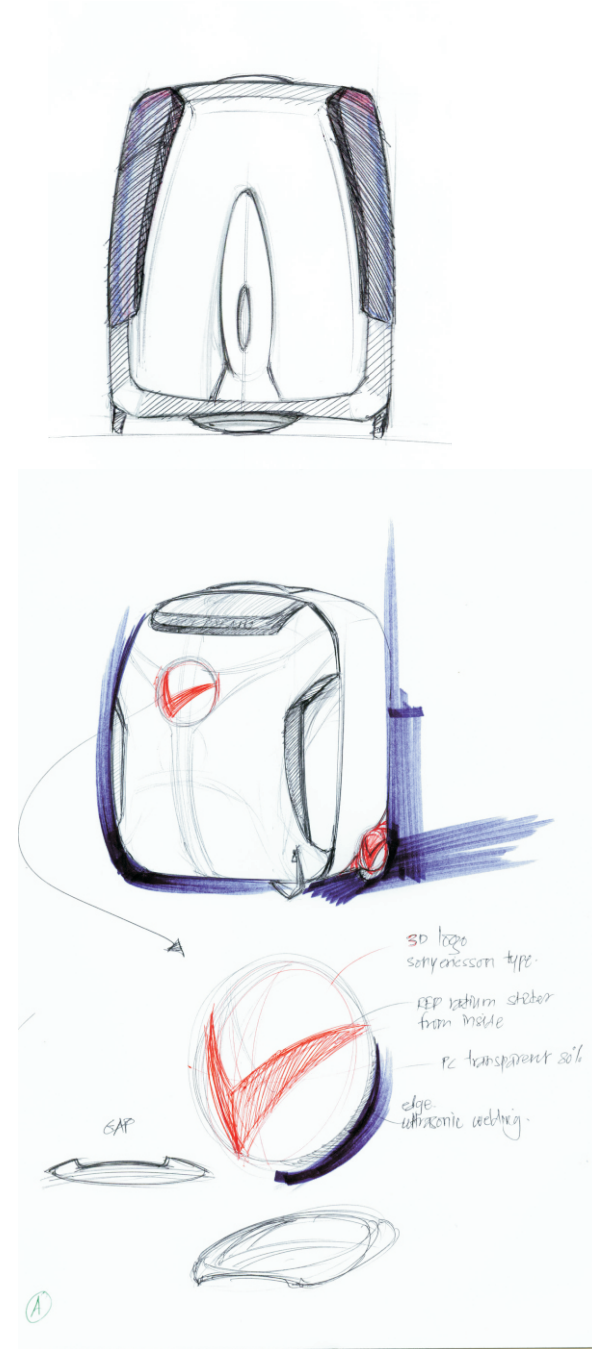

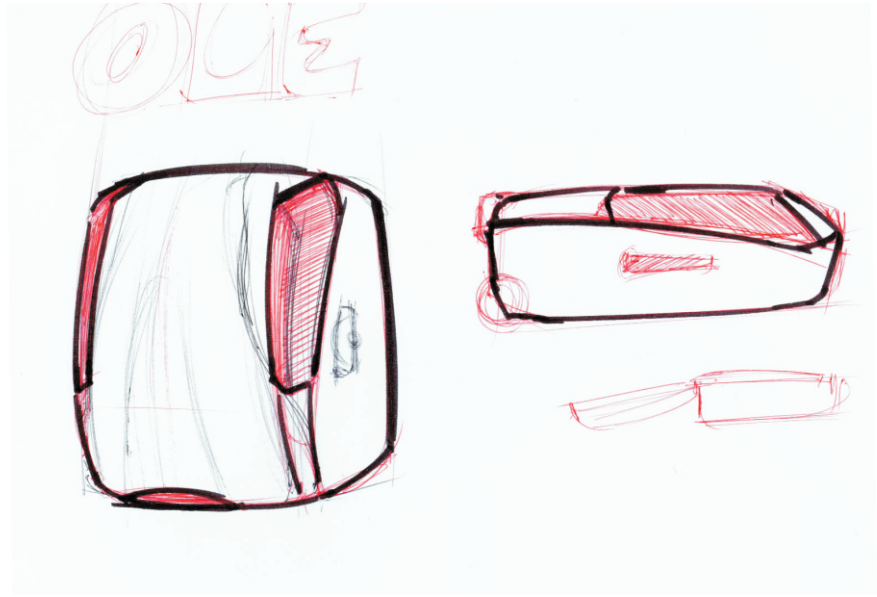
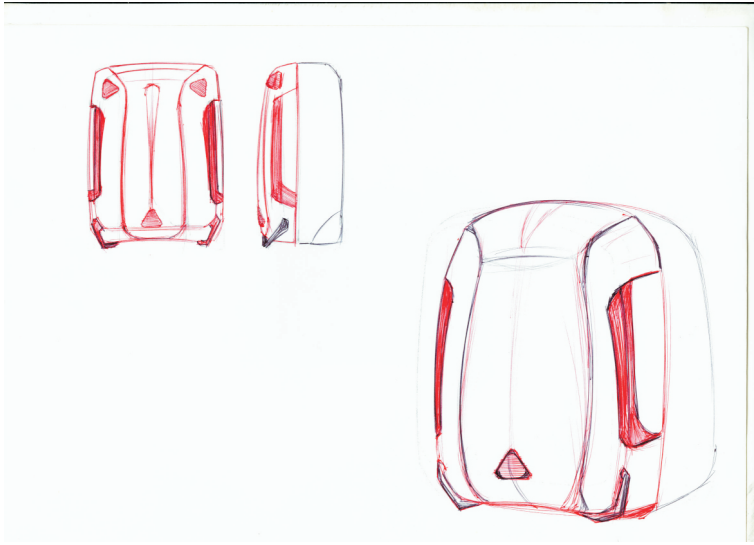

VISUALIZING BAG AS A WHOLE

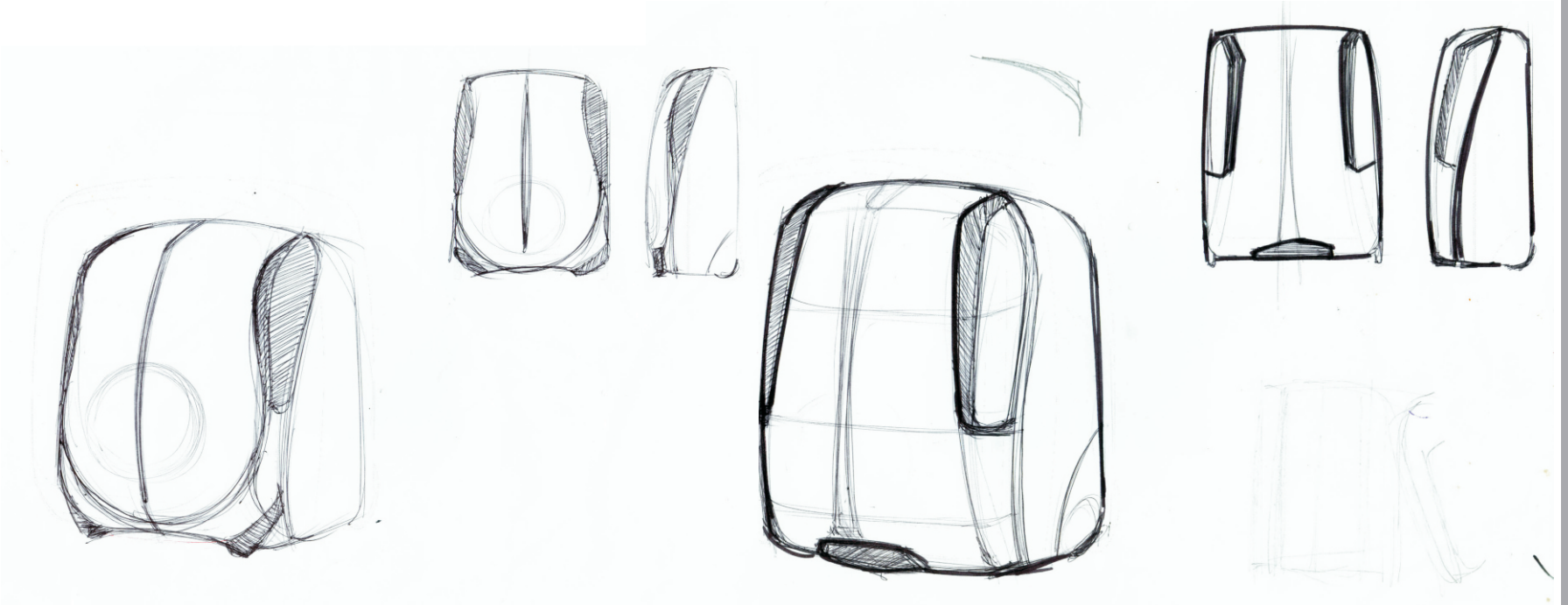

# PRODUCT BRIEF

Product brief further narrows down the design parameters. Possibilities regarding each component is stated & followed to help the process of concept generation

## stance orientation & size

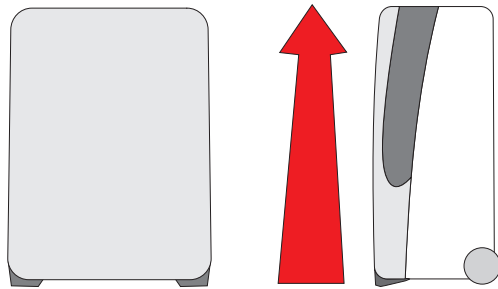

absolute vertical

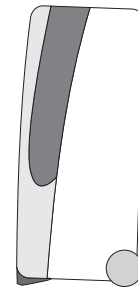

hinge at the bottom opens and stands vertical

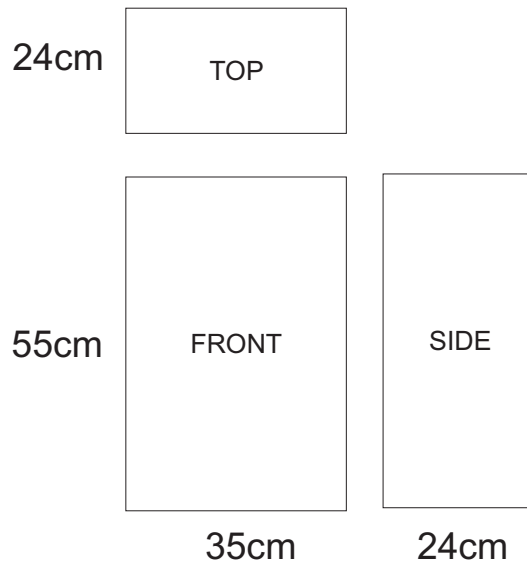
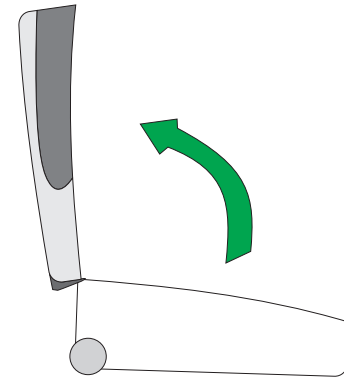

initially size in consideration is taken as 55cms that's cabin size luggage similar design will be adopted for the range of other luggage

*material combination*

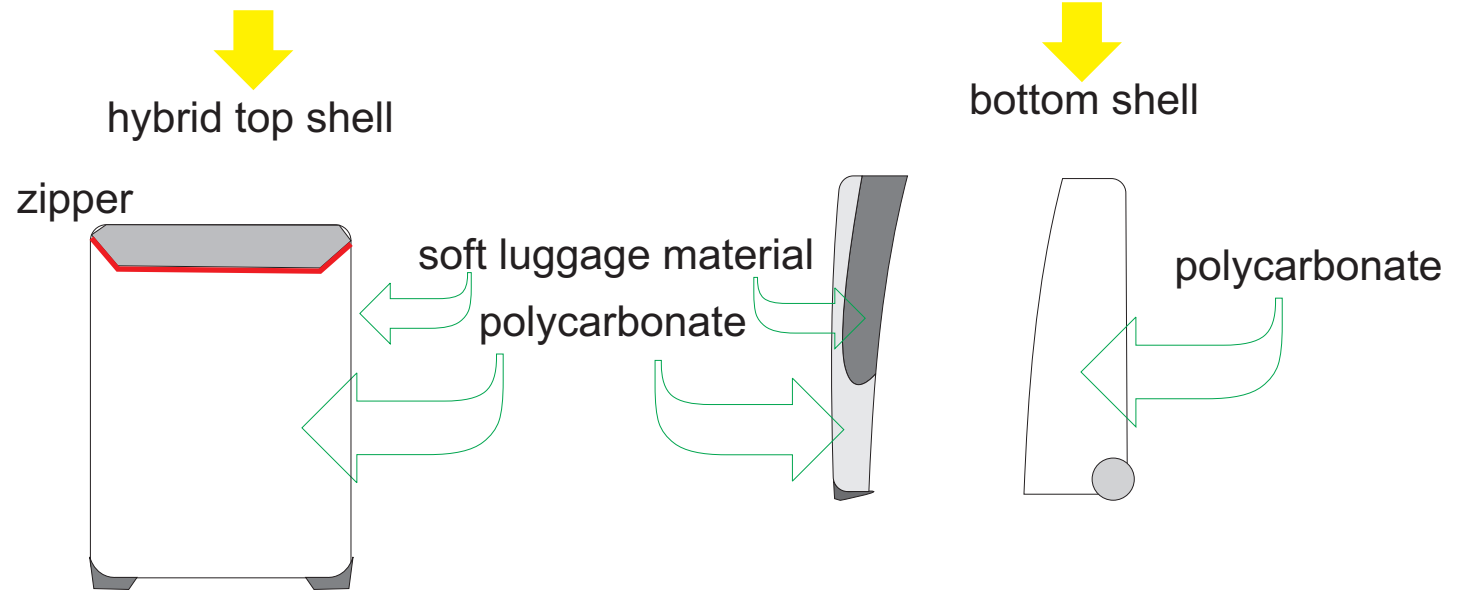

*colour & texture*

colour colours will be decided once the final design is complete  
bottom shell will have darker shade as compared top shell

colour combination for the hybrid front shell will be decided once the styling is freezed

texture polycarbonate surface will be glossy mirror finish for the top shell and can be relatively matte for the bottom shell

multi-textured finish is possible with dual mold impression vacuum forming

*locking & closing / opening*

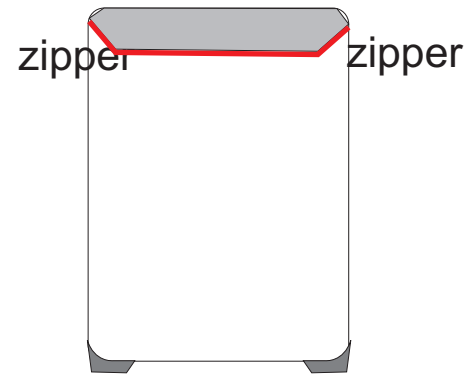

zipper closing will be such that minimizes the thickness of the bidding & closing detail  
pullers for the zippers will have styling blending with the bag styling

TSA lock for bigger size bag

TSA lock will be redesigned for better interaction and functional aspect  
optional locking for cabin size bag

*hybrid variation*

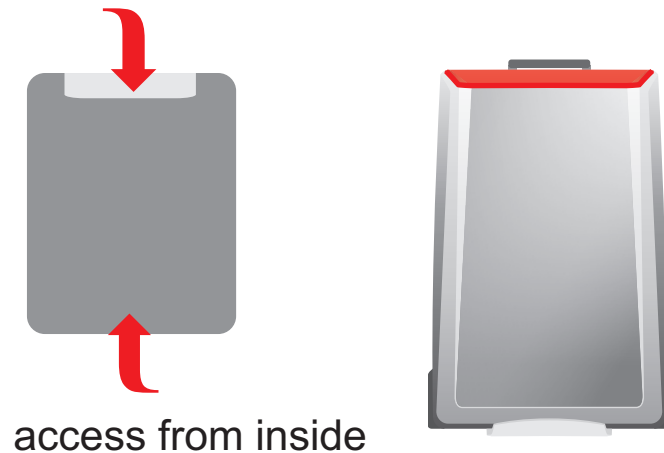

## trolley

**trolley projecting out of the surface  
yet fitted from inside**

**trolley integrated with top handle**

**v- frame trolley**

**collapsible trolley**

## wheels

**hubless wheels**

**ball and socket wheels**

**wheels integrated with lugs**

## lugs

**single lug at the centre**

**loop lug**

**three lugs**

**lug integrated with wheel**

## handle

**top handle integrated with trolley handle**

**loop handle**

**retractable handle with different mechanism**

## pullers

**reverse trouser pullers**

**magnetic puller**

**loop pullers**

## interior

**expander compensator take away bag**

**LED light inside bag**

**Layered packaging aid**

**compartment**

## *concepts* VARIATIONS

3 concept designs are generated, such that each concept will have different concept hardware and style. Adopting idea derived in idea clusters of each component are judiciously merged together to come up with three primary concepts. These concepts are evaluated to get the best possible out of them.



1



2



3

**CONCEPT 1**



**EVERLIFE**



**1**

 **EVERLIFE**



**ATUL PARANJPE 05613802 LUGGAGE DESIGN** 



EVERLIFE

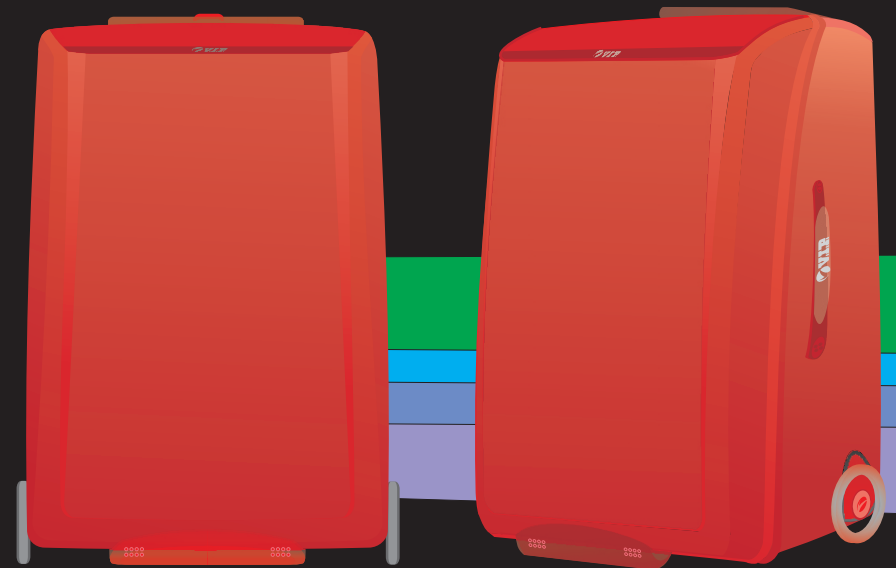

ATUL PARANJPE 05613802 **LUGGAGE DESIGN**  **V.I.P.**

EVERLIFE

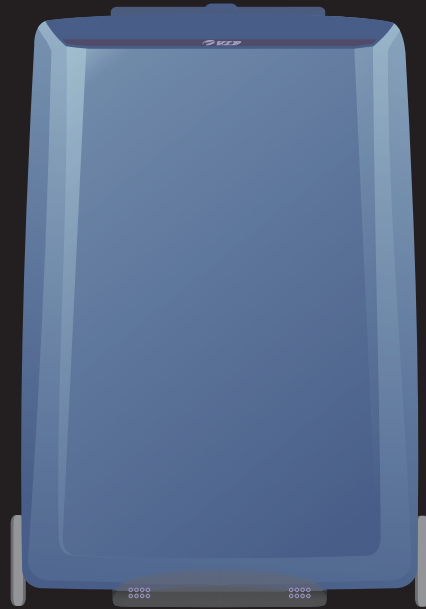
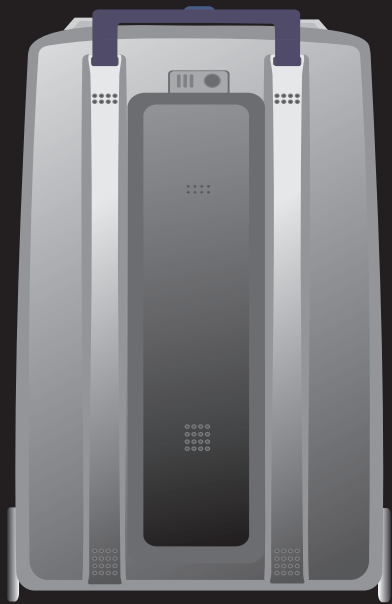

ATUL PARANJPE 05613802 **LUGGAGE DESIGN**  **V.I.P.**

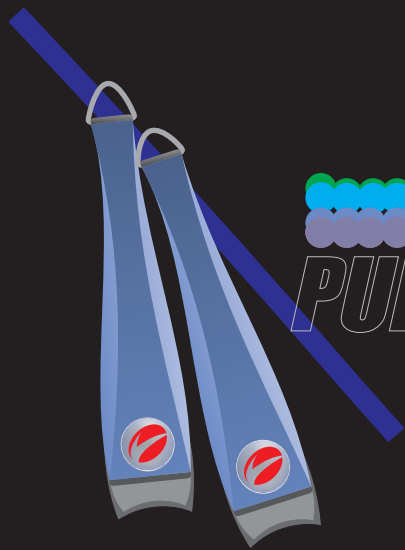

**PULLERS**

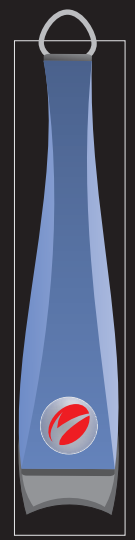

50MM

15MM

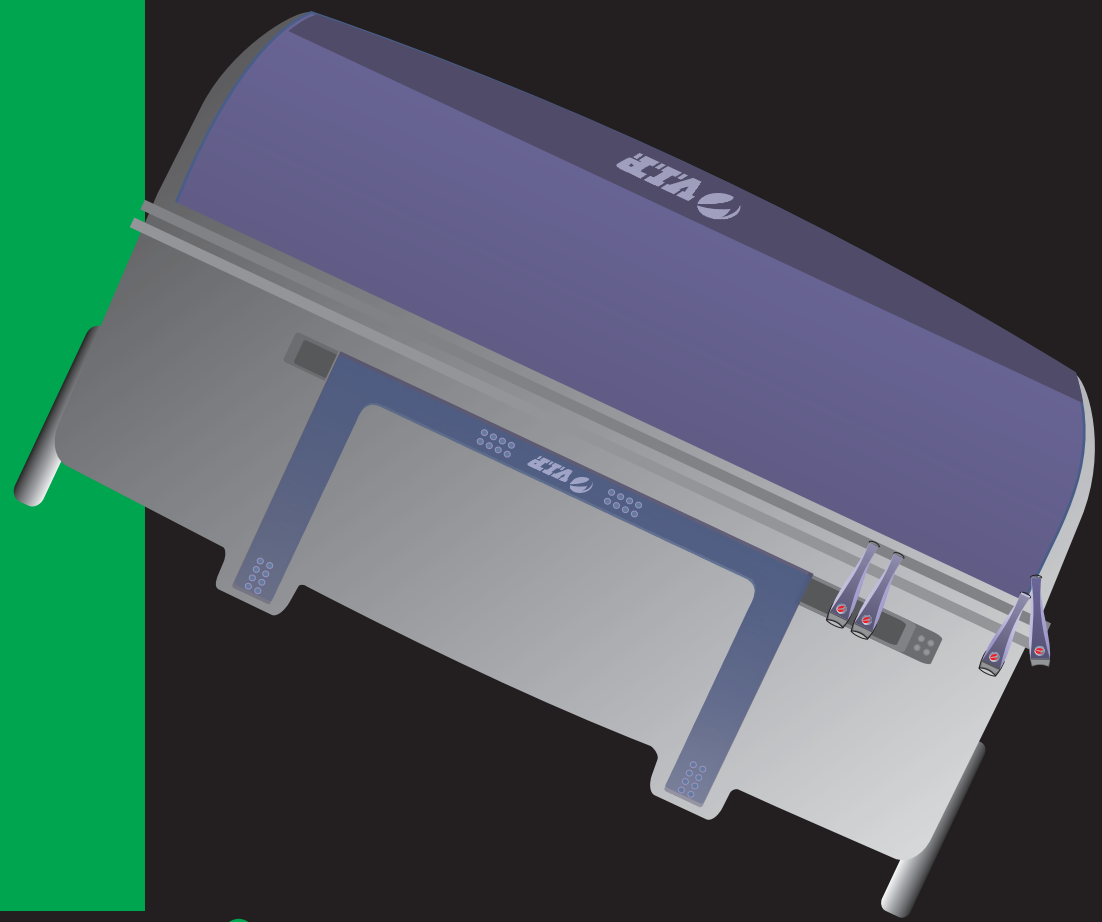

**TSA LOCK**



## WHEELS

HUB LESS WHEELS FITTED ON THE SIDE THAT HAS BRANDING AT THE CENTER AND IS ATTACHED TO BAG WITH RIVETS OR ULTRASONIC WELDING

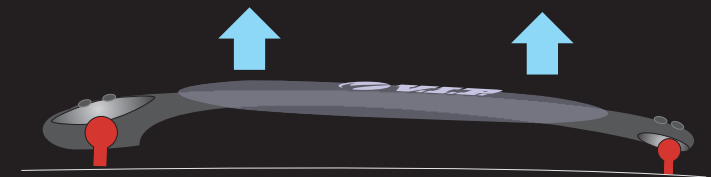

## SIDE HANDLE

SIDE HANDLE IS SYMMETRICALLY FITTED ON BOTH SIDES OF THE BAG, HENCE WHEN RIGHT SIDE HANDLE IS USED LEFT ONE SERVES AS GROUND REST AND VICE VERSA



## BOTTOM LUG

BOTTOM LUG IS FITTED AT THE CENTER AND HAS A CAVITY BENEATH THAT MAKES IT AS A LIFT HANDLE AND ALSO REDUCES WEIGHT & MATERIAL COST.

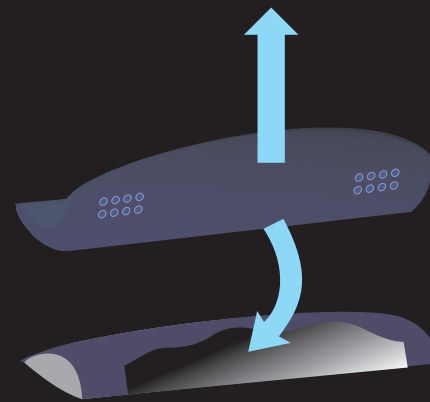

FRONT SHELL OPENS AT APPROXIMATELY 110 DEGREES AND STAYS THERE WITH THE LUGS RESTING ON BOTTOM SHELL SURFACE





*TROLLEY*

+



*HANDLE*

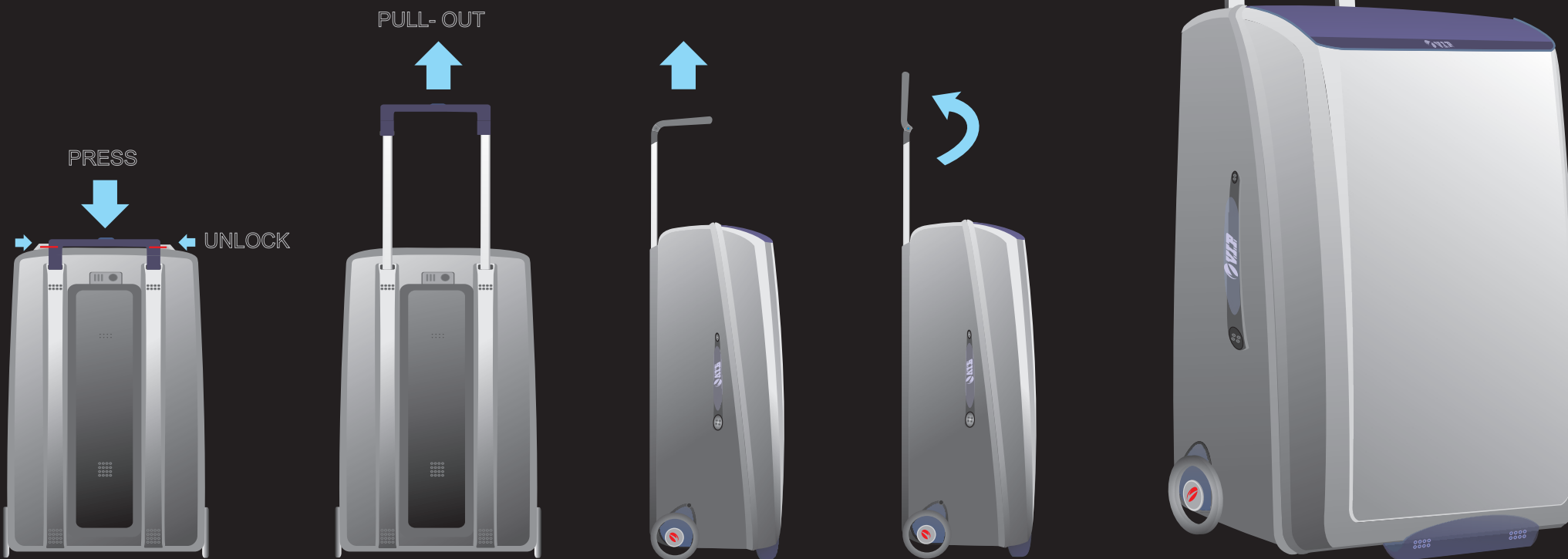

*ATUL PARANJPE* 05613802 **LUGGAGE DESIGN** 

USUALLY STUFF INSIDE LUGGAGE IS ALWAYS MORE WHILE JOURNEY BACK HOME BECAUSE OF SHOPPING ETC. HENCE NORMALLY EXPANDER HELPS YOU OUT WITH THAT. HERE THE MESSENGER BAG SERVES AS EXPANDER COMPENSATOR AND PROVIDES EVEN MORE SPACE FOR EXTRA STUFF.



## EXPANDER COMPENSATOR

COLLAPSIBLE MESSENGER BAG IS PLACES AT THE PLACE BETWEEN TROLLEY STEMS THIS BAG WILL BE IN USE WHILE LOCAL ROAM AROUND ONCE YOU REACH THE PLACE

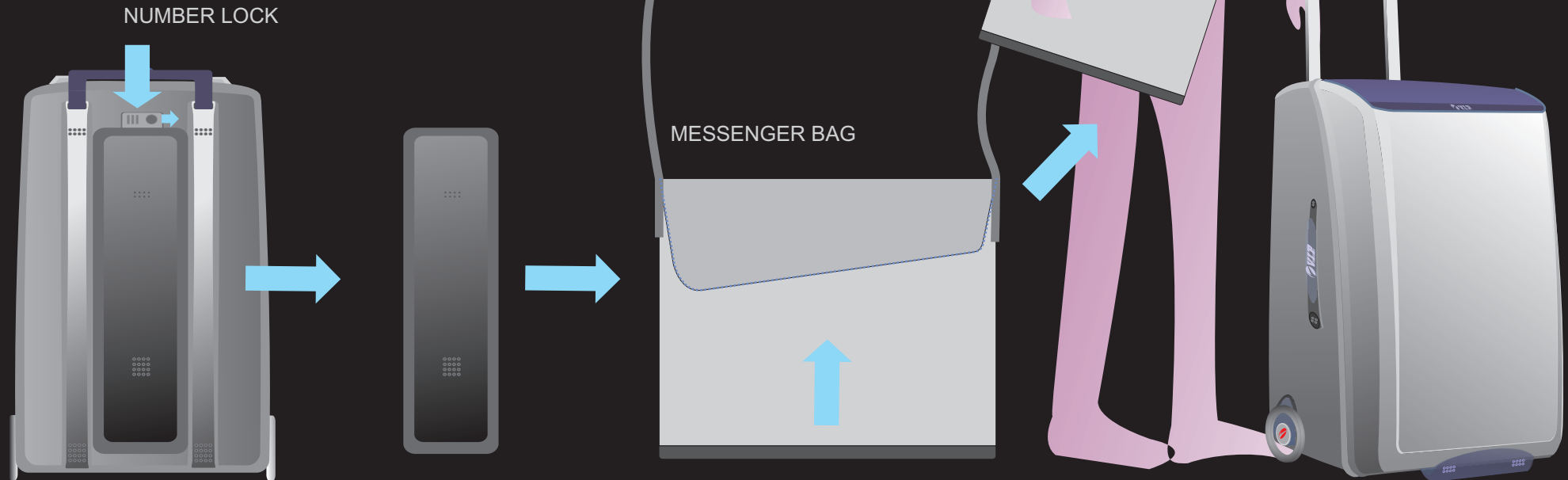



VOLUME 1  
EXTERNAL ACCESS

VOLUME 2  
INTERNAL ACCESS

FRONT SHELL

USUALLY THE THINGS WE NEED DURING THE TRAVEL ARE KEPT IN OUTER EXTERNALLY ACCESSIBLE POCKET IN THE FRONT SHELL. SO THAT USER DON'T NEED TO OPEN UP WHOLE BAG TO ACCESS THE THINGS HE NEEDS DURING THE JOURNEY. AT THE SAME TIME THIS KEEPS DIRTY FOOTWEAR OR WET TOILETRY POUCH AWAY FROM NEAT & IRONED CLOTHES

FORMED EVA TOP COVER

SHOE POUCH



TOILRTRY POUCH



EYE-WEAR ETC



**INTERIORS**

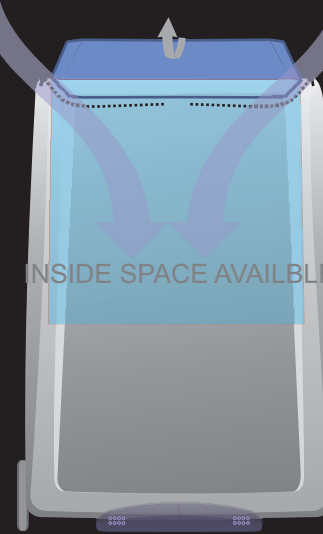

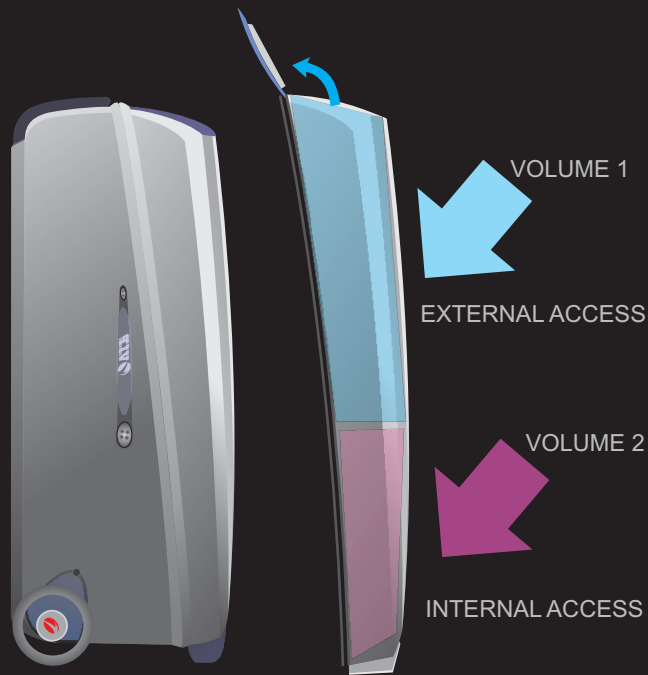

DETAIL SIMILAR TO SLING BAG

USED CLOTHES, JUNK WEAR,  
NIGHT WEAR ETC

TRANSPARENT POCKET  
WITH ZIPPER

PAPERS, DOCUMENTS  
BOOKS ETC

## FRONT SHELL

FRONT SHELL OPENS AT  
APPROXIMATELY 110 DEGREES  
AND STAYS THERE WITH THE LUGS  
RESTING ON BOTTOM SHELL SURFACE

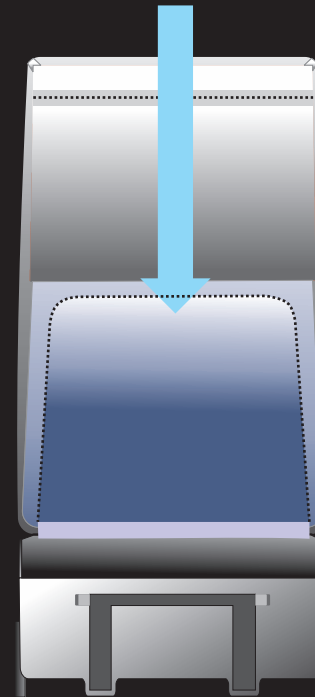
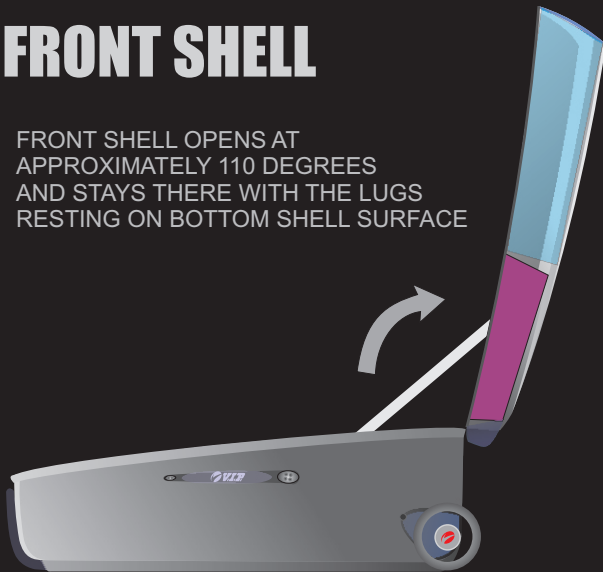

HINGE

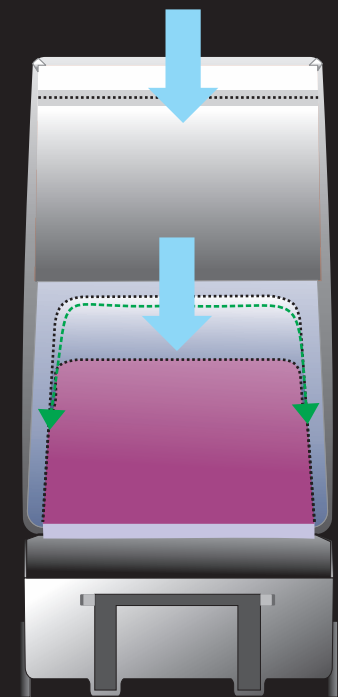



MAIN VOLUME

## BOTTOM SHELL

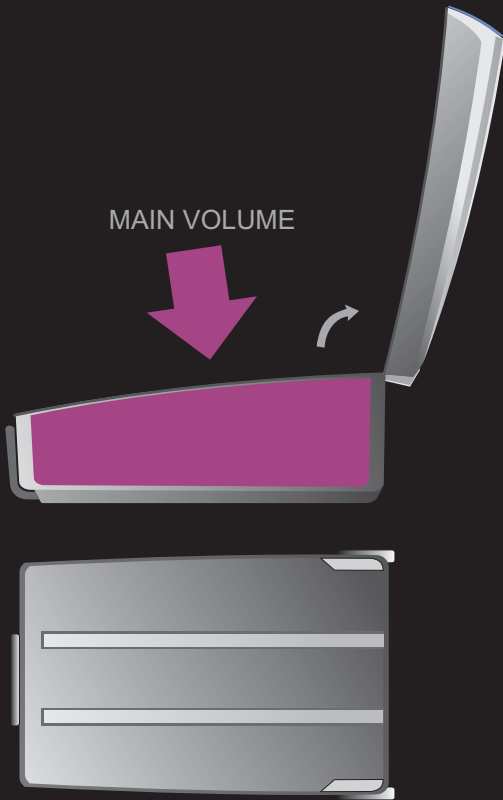

MAIN VOLUME

TOP VIEW

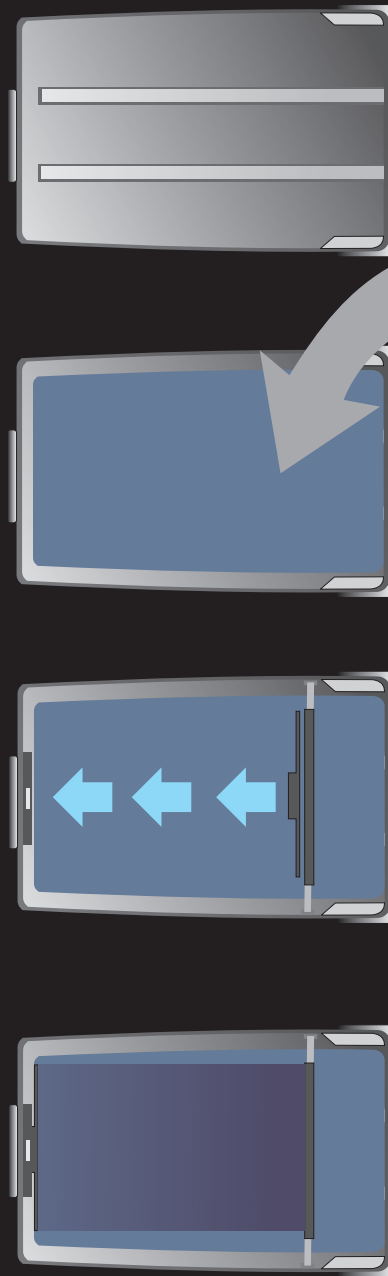

THIN PVC MAT STUCK ON THE BOTTOM THAT COVER UP THE TROLLEY STEMS AND INSIDE SURFACE IS SMOOTH, LEVELED AND NEAT.

DIVIDER THAT IS FITTED WITH THE (LPA) LAYERED PACKING AID COMPONENT. THIS HELPS IN PACKING THE LUGGAGE WHERE ONE CAN LAYER APART HIS FORMAL IRONED CLOTHES.

MAIN VOLUME

TOP VIEW

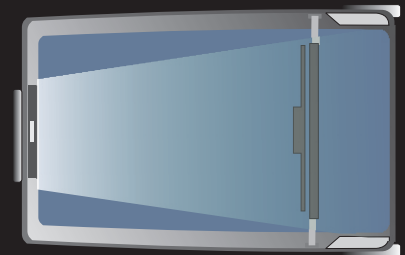

INTERNAL LIGHTING AID WITH PANEL FITTED WITH 4 LED'S AND A BUTTON BATTERY THAT THROWS ENOUGH BRIGHT LIGHT TO LOCATE THE THINGS INSIDE AT NIGHT THIS IS FITTED ON THE EXACT BACK SIDE OF THE LOCK FITTING AND ALSO HOOKS IN THE LPA

**CONCEPT 2**

**OLE!**

**ORIGINAL LIMITED EDITION** 

2

**OLE!**

ORIGINAL LIMITED EDITION 



ATUL PARANJPE 05613802 **LUGGAGE DESIGN** 

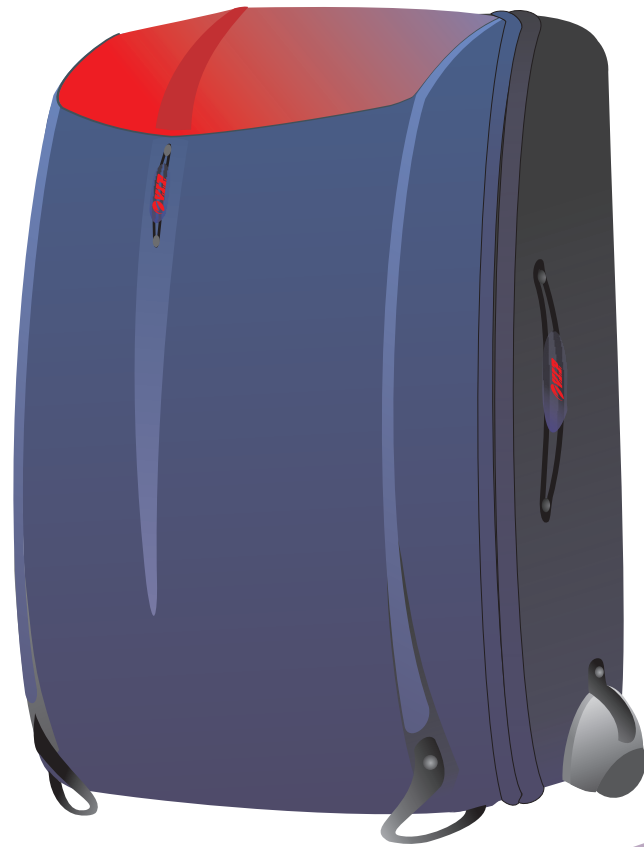

**OLE!**

**ORIGINAL LIMITED EDITION** 

**ATUL PARANJPE 05613802 LUGGAGE DESIGN** 

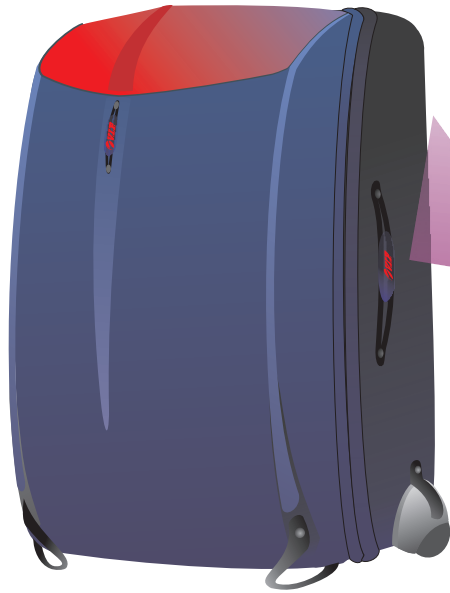

*side handle*

metal wire reinforced  
nylon loop

translucent flexible PC  
grip with logo embossed  
or painted

nylon stud that hold the  
handle with bag

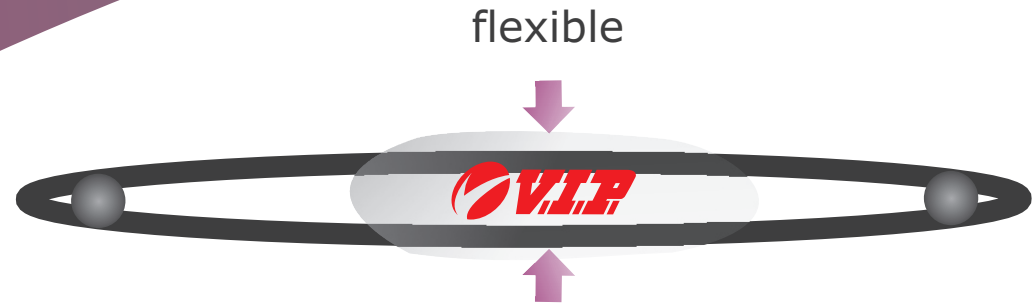



**bottom lug**



slight depression where  
lug is fitted

metal or nylon lug fitted  
with rivet

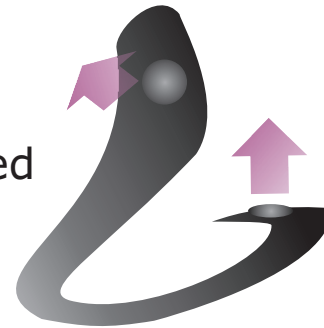

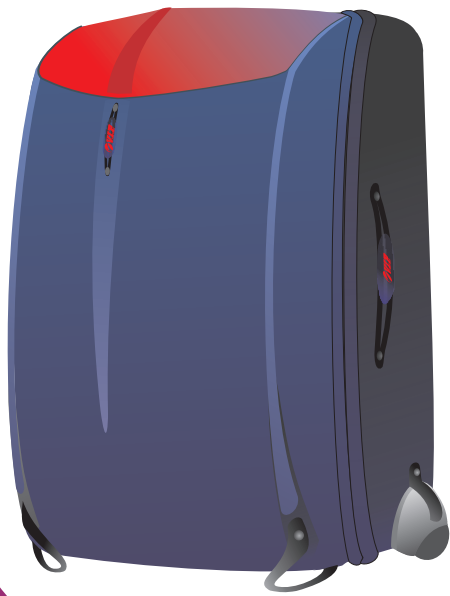

**wheels**



ball and socket 360 degree wheel

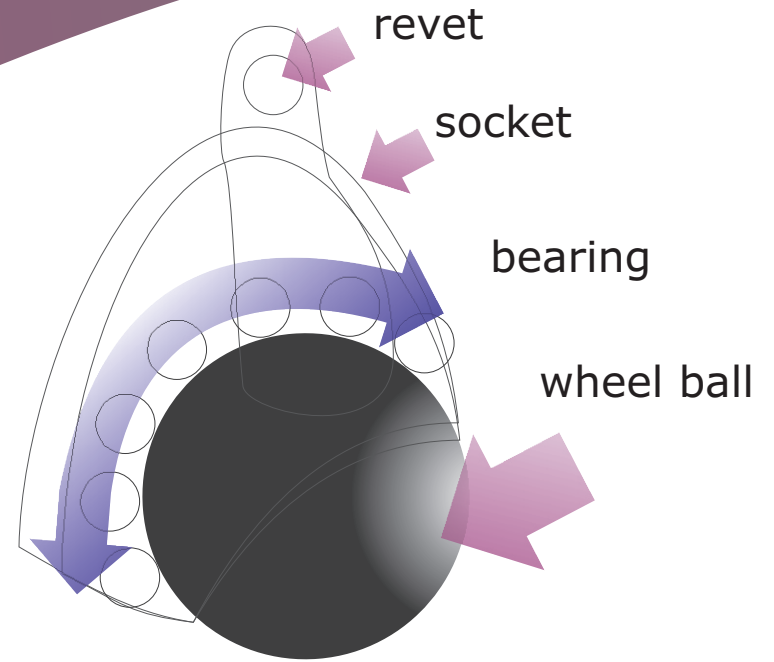



pressing the button reduces the angle for v framed trolley and thus it freely moves out

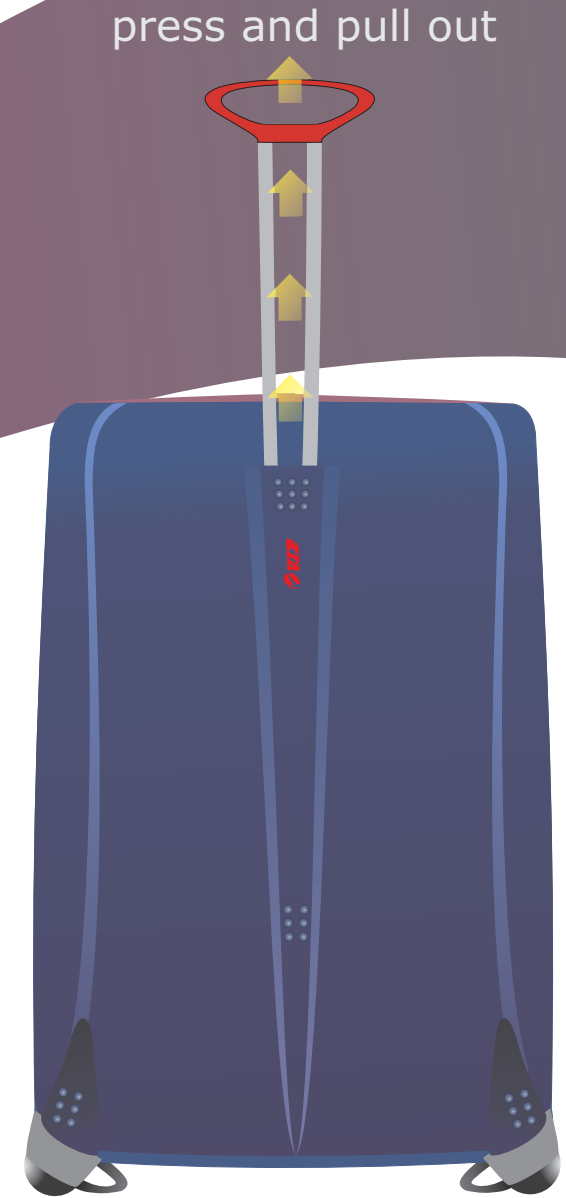
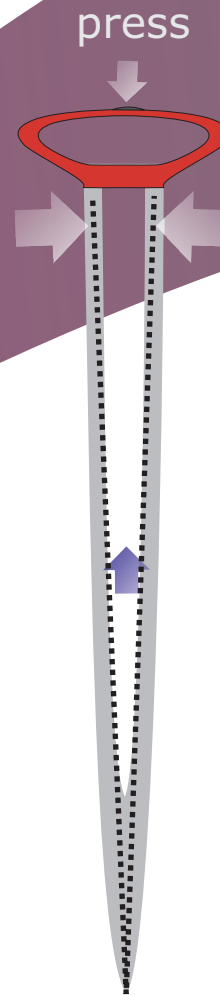

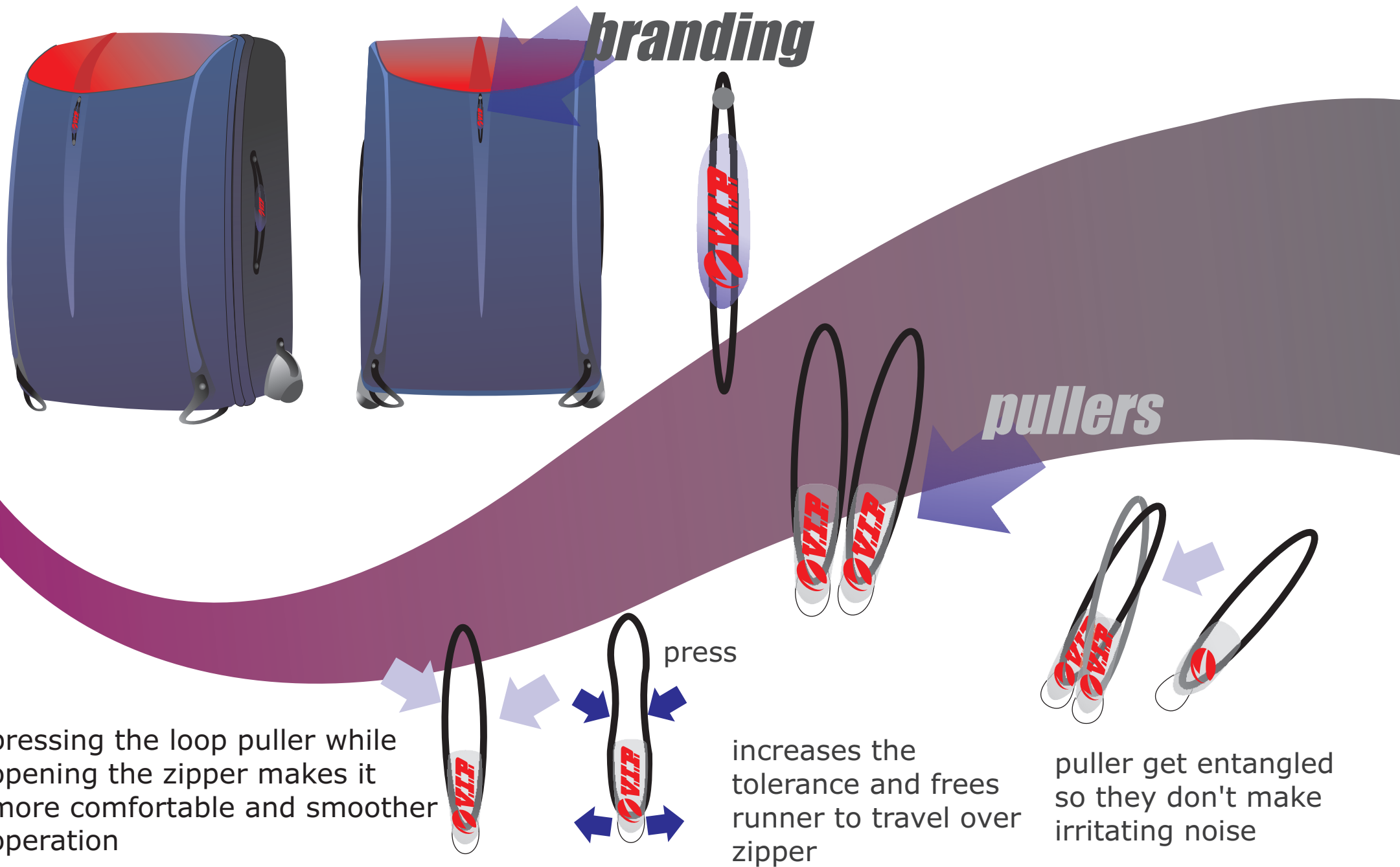

# interiors

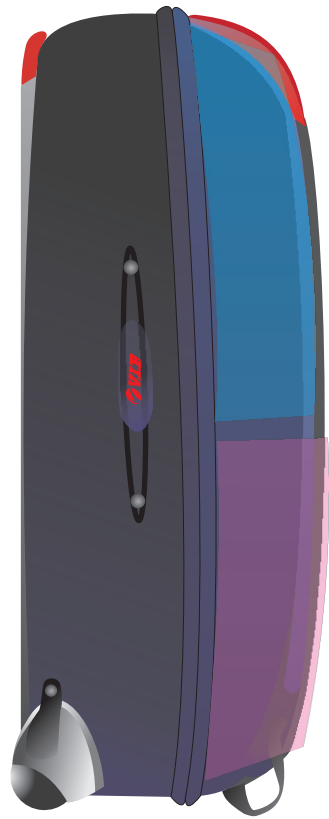

volume 1  
external access



volume 2  
internal access

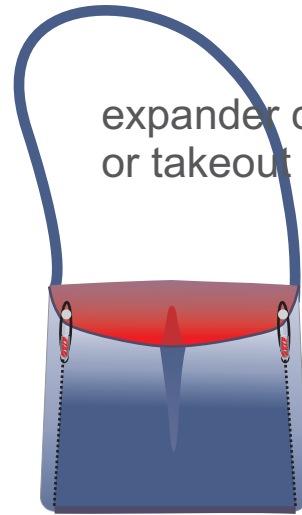

expander compensator  
or takeout bag

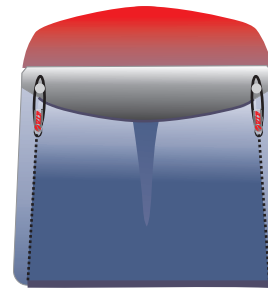

used clothes, junk wear,  
night wear etc

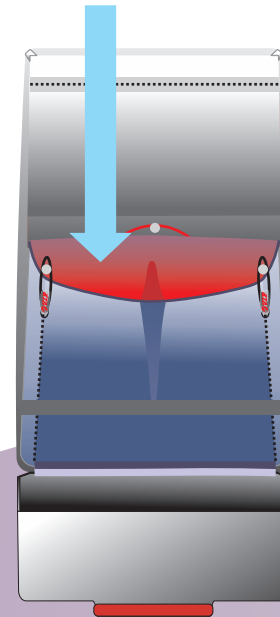

transparent pocket  
with zipper

papers, documents  
books etc

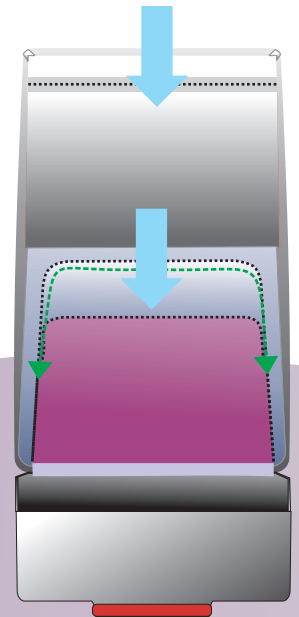

# CONCEPT 3

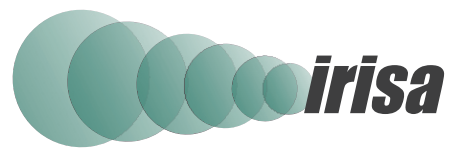



ATUL PARANJPE 05613802 **LUGGAGE DESIGN**  **VIER**

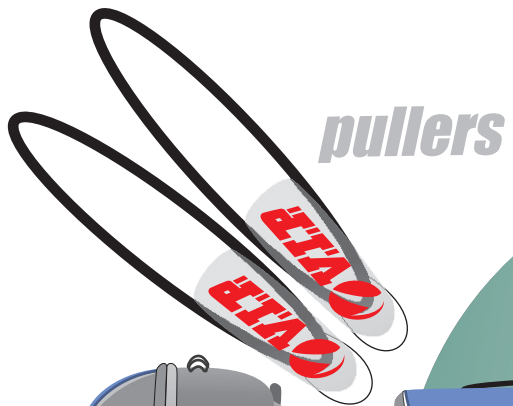

*irisa* <sup>loop</sup>

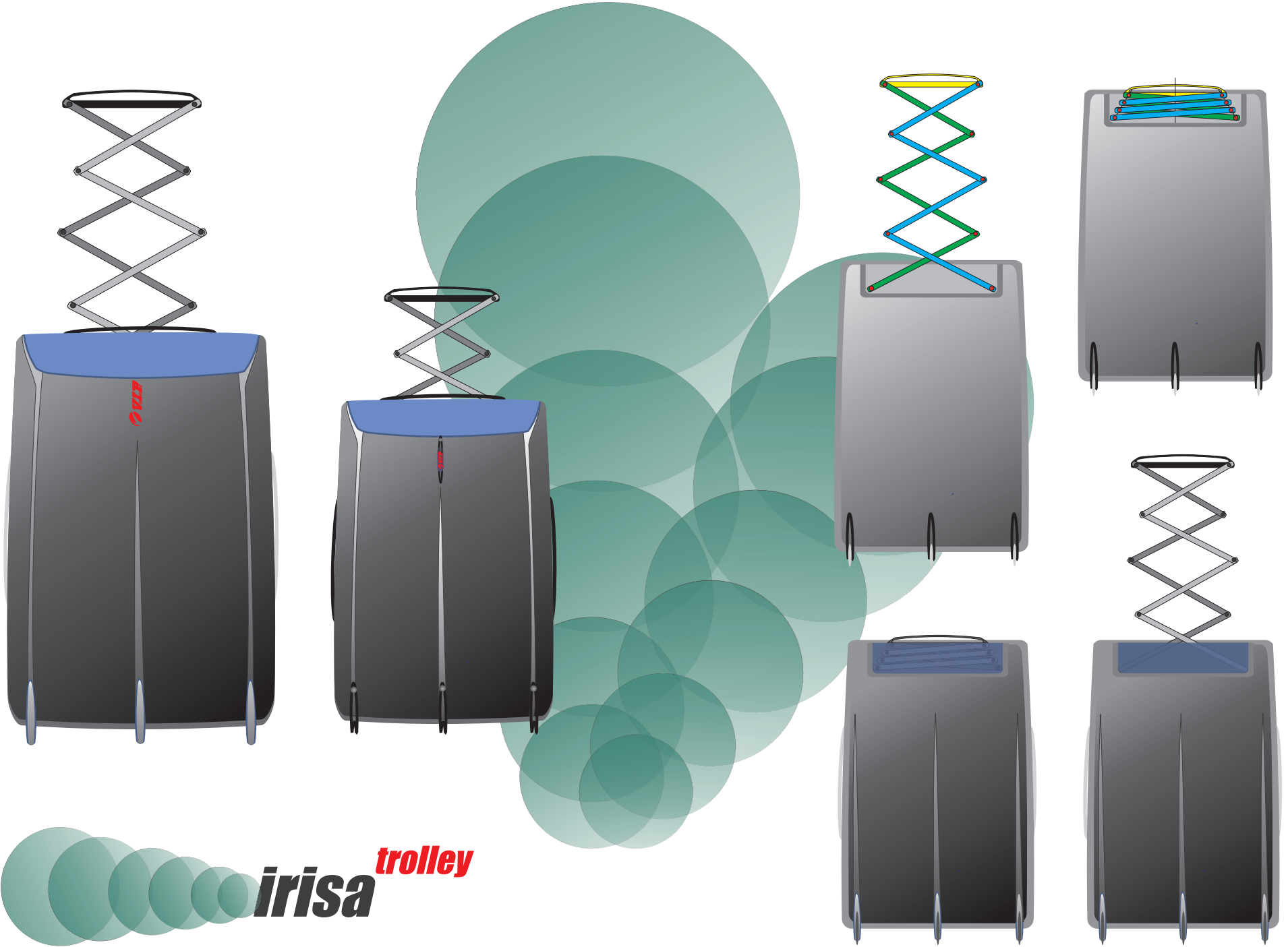

**irisa** *trolley*

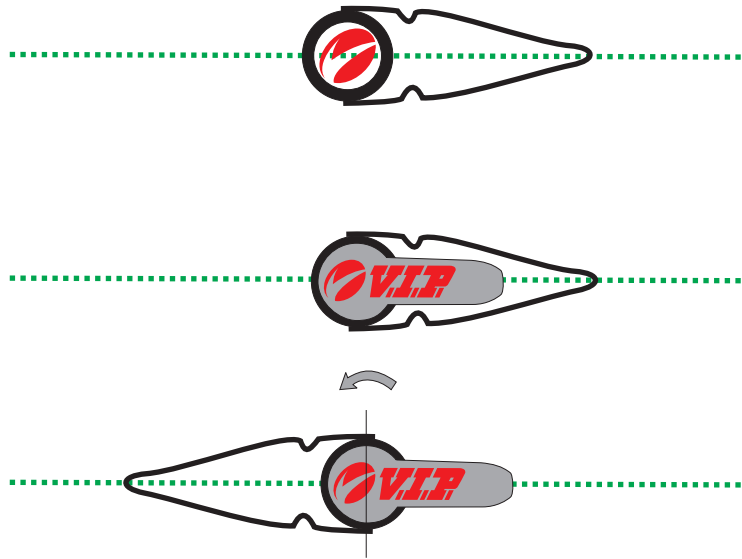

trouser pullers that has flip-up and lock feature



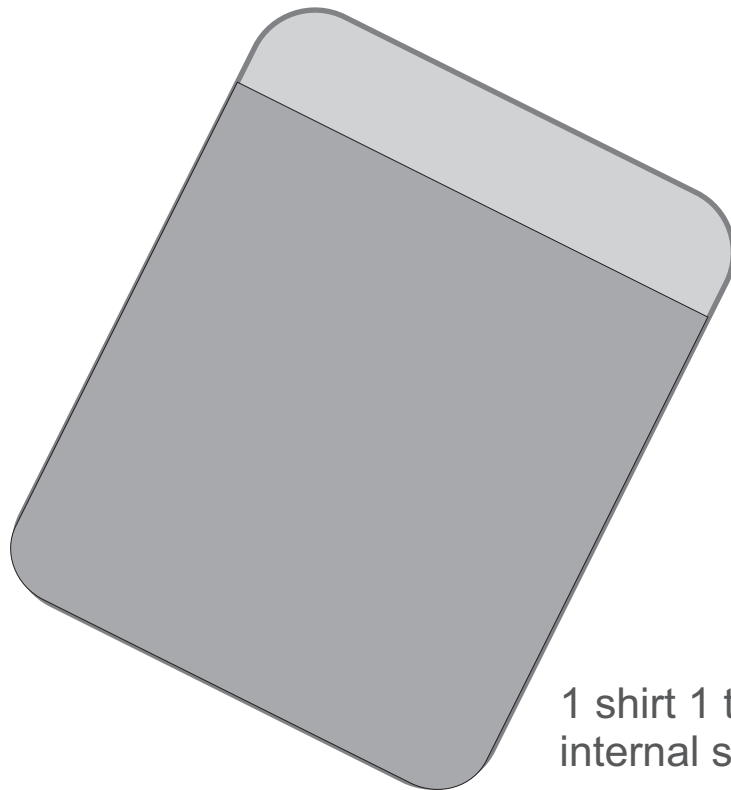

1 shirt 1 trousers and a tie fits in this internal seperator

# CONCEPT evaluation

## CONCEPT 1



## CONCEPT 2



## CONCEPT 3



	CONCEPT 1	CONCEPT 2	CONCEPT 3
overall styling	● ● ● ○ ○	● ● ● ● ● ○ thumbs up	● ● ● ● ● ○ thumbs up
trolley concept	● ● ● ○ ○	● ● ● ● ● thumbs up	● ● ○ ○ ○
wheel concept	● ● ● ○ ○	● ● ● ● ○	● ● ● ● ● thumbs up
lug concept	● ● ○ ○ ○ thumbs up	● ● ● ● ○ thumbs up	● ● ● ● ● thumbs up
interior concept	● ● ● ● ○ thumbs up	● ● ● ○ ○	● ● ● ○ ○
puller concept	● ● ● ● ● thumbs up	● ● ● ● ○	● ● ● ● ● thumbs up
branding concept	● ● ● ● ○ thumbs up	● ● ● ○ ○	● ● ● ● ○

none of the concept is entirely dominating so final concept is amalgamation of the best features from each concept.

# *final concept*

**final concept**

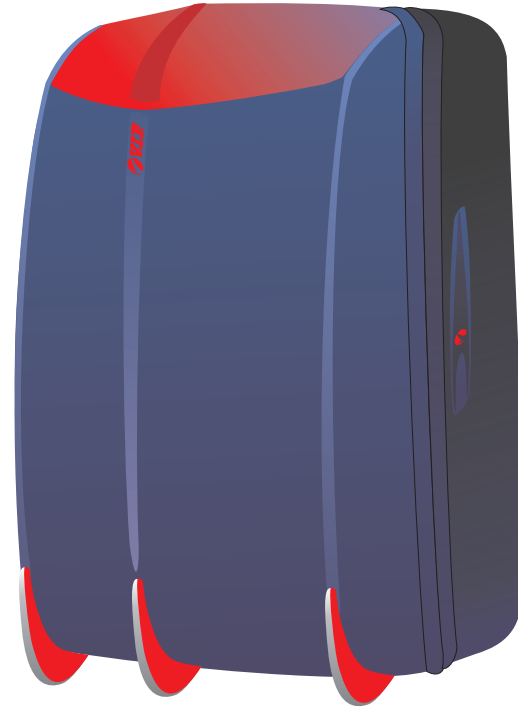
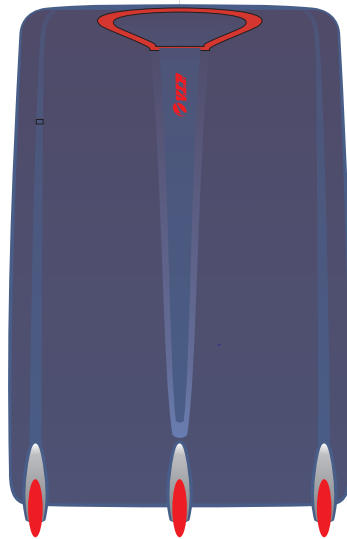
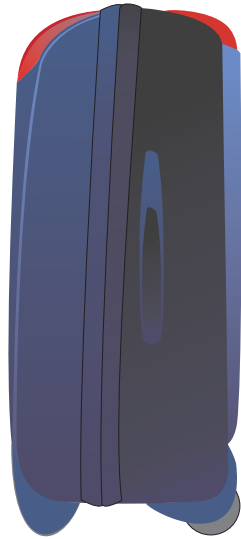
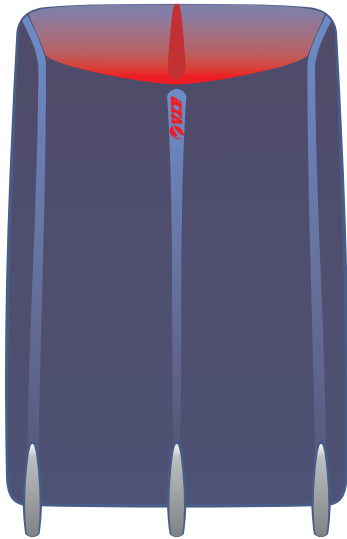
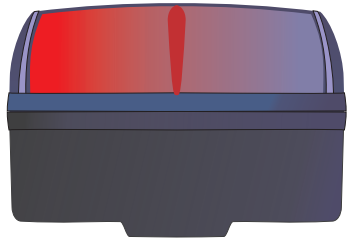



# SIDE HANDLE

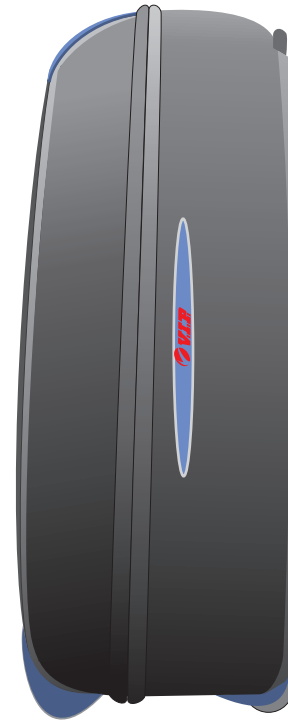
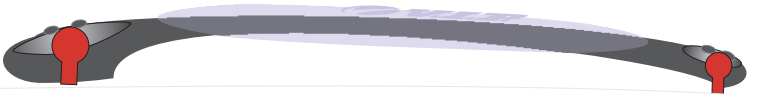
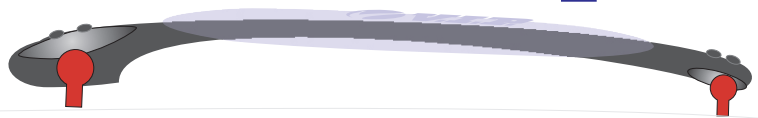



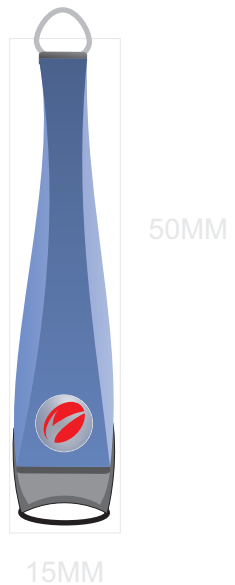
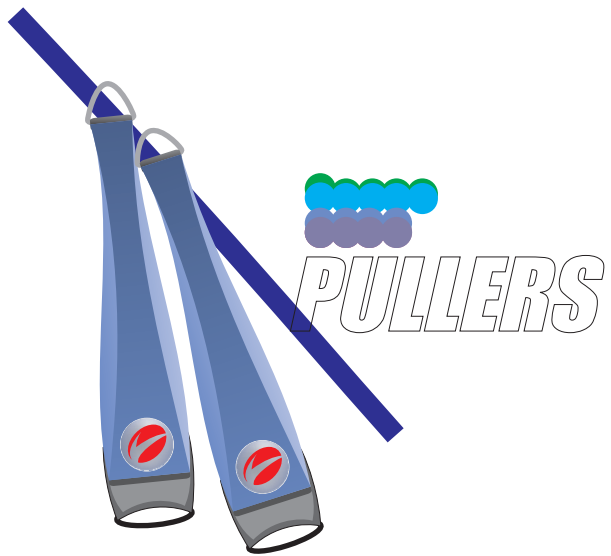

press

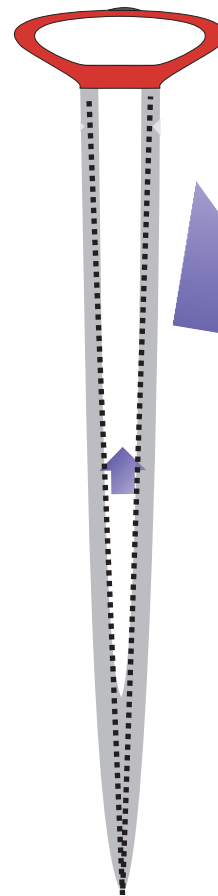
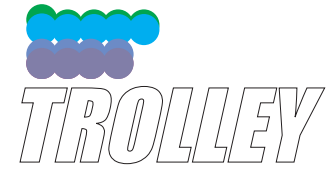

press and pull out





***branding***

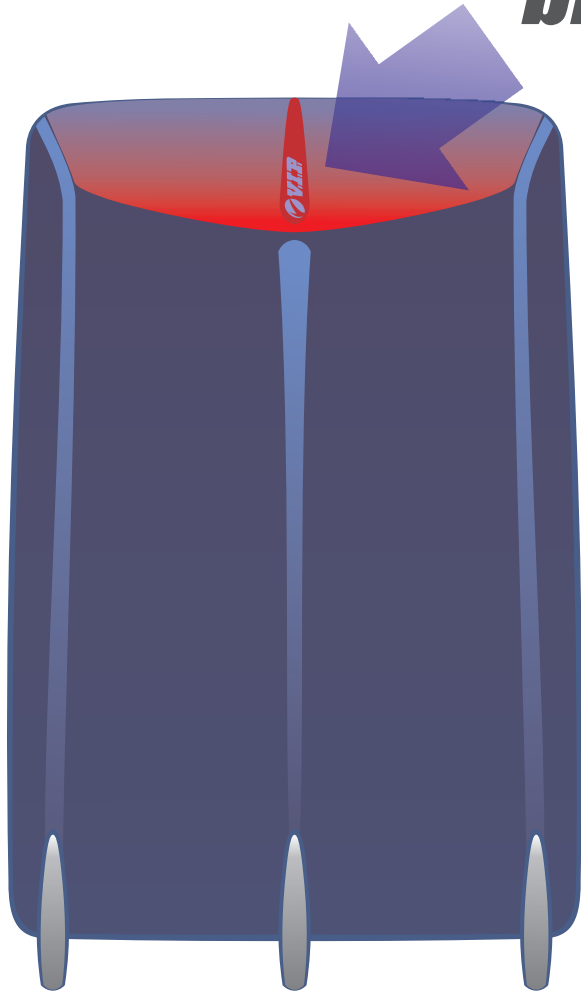

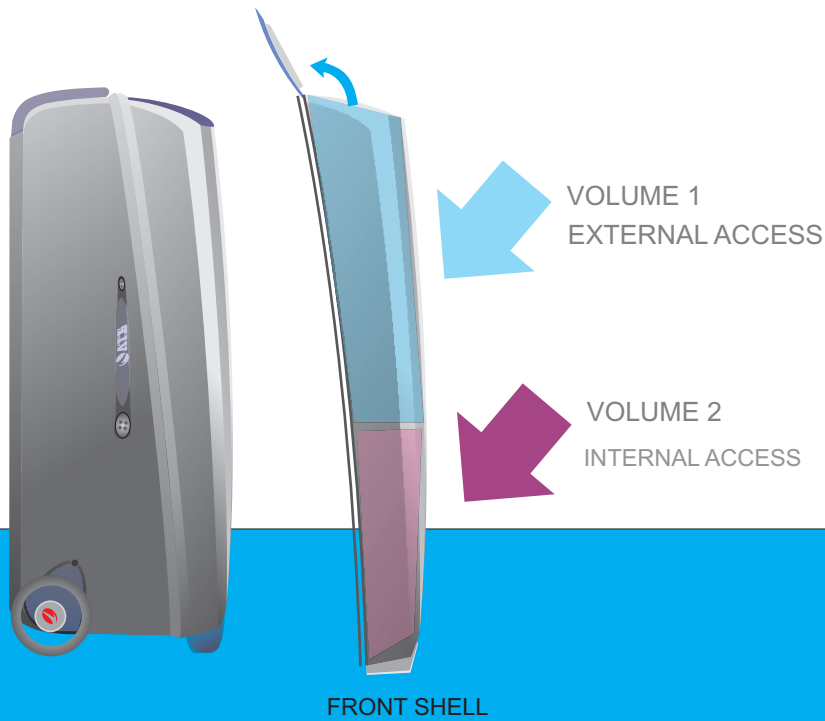

USUALLY THE THINGS WE NEED DURING THE TRAVEL ARE KEPT IN OUTER EXTERNALLY ACCESSIBLE POCKET IN THE FRONT SHELL. SO THAT USER DON'T NEED TO OPEN UP WHOLE BAG TO ACCESS THE THINGS HE NEEDS DURING THE JOURNEY. AT THE SAME TIME THIS KEEPS DIRTY FOOTWEAR OR WET TOILETRY POUCH AWAY FROM NEAT & IRONED CLOTHES

SHOE POUCH



TOILRTRY POUCH



EYE-WEAR ETC



FORMED EVA TOP COVER



INTERIORS

# interiors

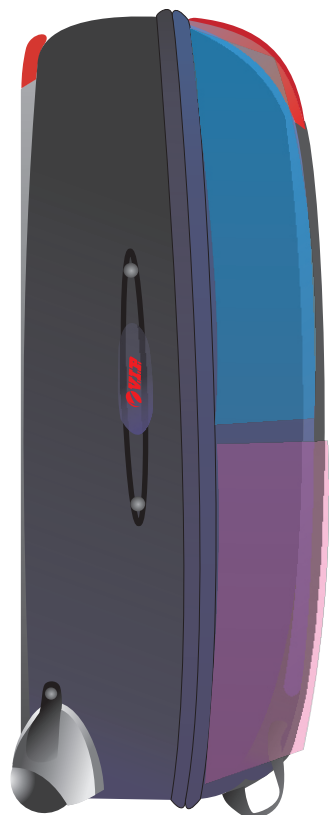

volume 1  
external access



volume 2  
internal access



expander compensator  
or takeout bag

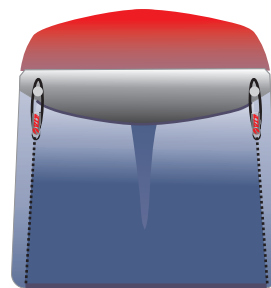
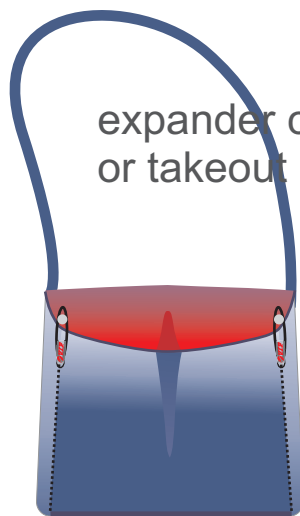

used clothes, junk wear,  
night wear etc

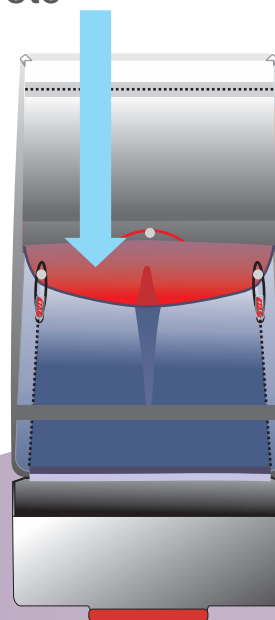

transparent pocket  
with zipper

papers, documents  
books etc

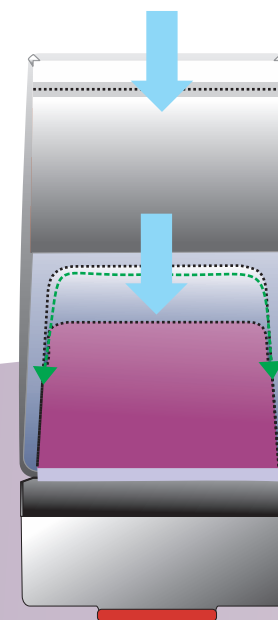



MAIN VOLUME

## BOTTOM SHELL

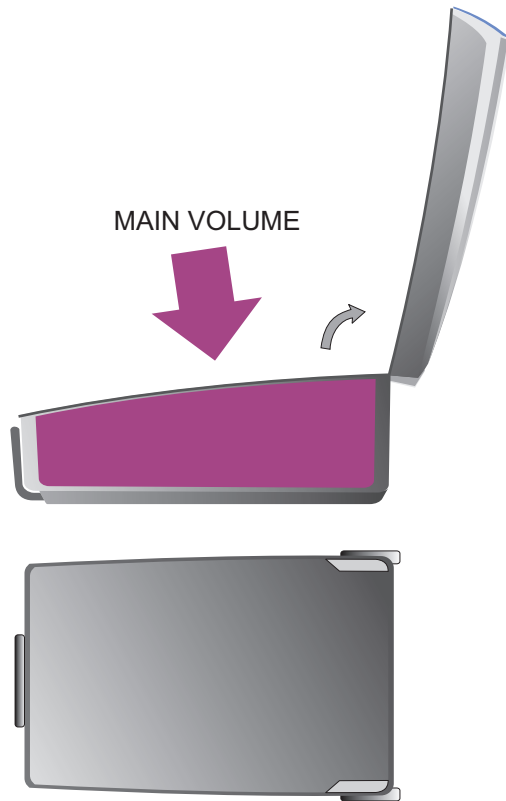

MAIN VOLUME

TOP VIEW

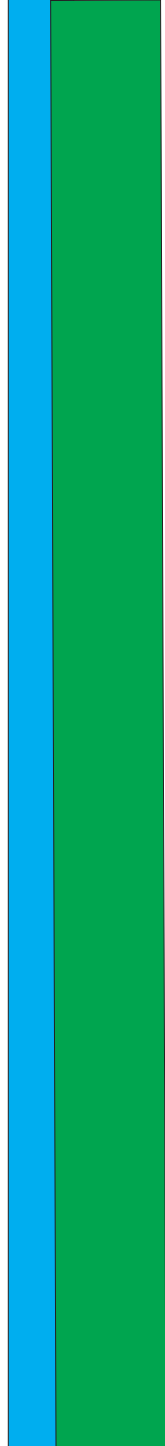

THIN PVC MAT STUCK ON THE BOTTOM THAT COVER UP THE TROLLEY STEMS AND INSIDE SURFACE IS SMOOTH, LEVELED AND NEAT.

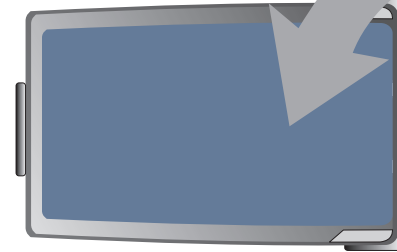

DIVIDER THAT IS FITTED WITH THE (LPA) LAYERED PACKING AID COMPONENT. THIS HELPS IN PACKING THE LUGGAGE WHERE ONE CAN LAYER APART HIS FORMAL IRONED CLOTHES.

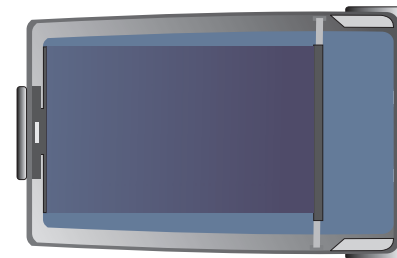
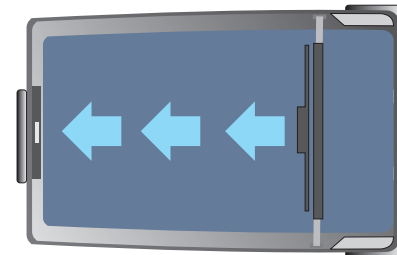

INTERNAL LIGHTING AID WITH PANEL FITTED WITH 4 LED'S AND A BUTTON BATTERY THAT THROWS ENOUGH BRIGHT LIGHT TO LOCATE THE THINGS INSIDE AT NIGHT  
THIS IS FITTED ON THE EXACT BACK SIDE OF THE LOCK FITTING AND ALSO HOOKS IN THE LPA

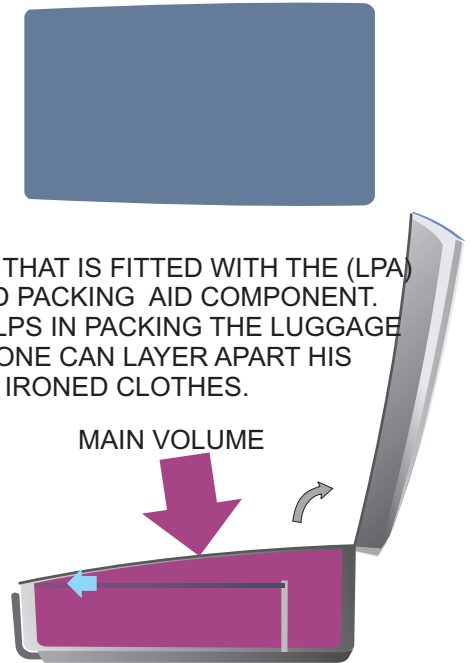

MAIN VOLUME

TOP VIEW

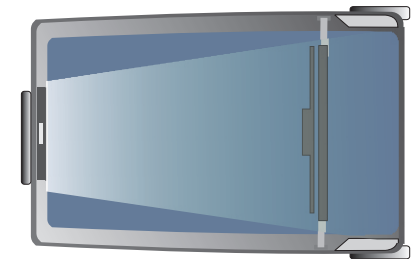

# Drawing

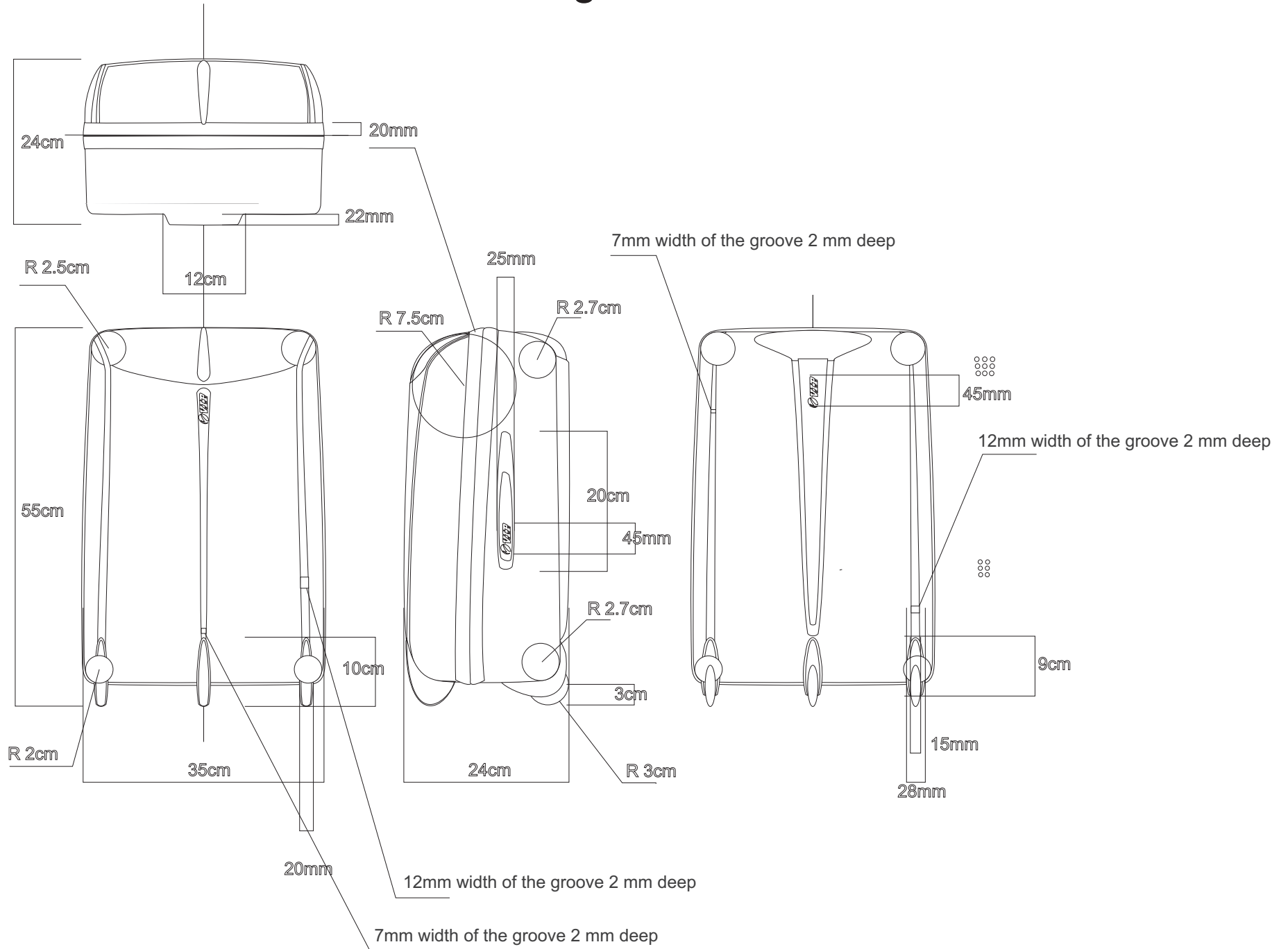



ATUL PARANIPE 05613802  
**LUGGAGE DESIGN** 



**journey in progress**