



ATUL PARANJPE 05613802

LUGGAGE DESIGN  **V.I.P.**





Project III
Luggage design

Submitted by
Atul Paranjpe
05613802

Project Guide
Prof. Chakravarthy
IDC, IIT Bombay

Co-guide
Mr. Satyajit Vetoskar
Design Head, VIP Luggage

Product Design
Industrial Design Centre
IIT Bombay

APPROVAL SHEET

The project titled "Luggage design" by Atul Paranjpe is approved for the partial fulfillment of the requirement for the degree of `Master of Design' in industrial design.

Guide: _____

Co-guide: _____

Chairperson: _____

Internal examiner: _____

External examiner: _____

Date: _____

CONTENT

Acknowledgement	1	E. Product brief	62
A. About the project		F. Concept generation	
1. Introduction	2	1. Concept 1	67
2. The thought	3	2. Concept 2	79
3. Objective and expected learning	4	3. Concept 3	88
4. Methodology	5	4. Concept evaluation	94
B. Data collection for understanding luggage		G. Final concept	
1. Terminology	8	1. Concept detailing	95
2. Types of luggage	9	2. Drawings	96
3. Luggage accessories	10		
4. Classification	11		
5. Manufacturing & materials	12		
6. Luggage & interaction	14		
C. Appreciation			
1. Objective	23		
2. User	24		
D. Analysis & ideation			
1. Upright stance & form	28		
2. Upright colours	29		
3. Upright texture & finish	30		
4. Upright sizes	31		
5. Upright components	32		
6. Trolley	33		
7. Wheels	39		
8. Lug	44		
9. Handle	46		
10. Lock	49		
11. Interiors	50		
12. Pullers	53		
13. Hybrid variation	55		
14. Visualizing bag as a whole	56		

ACKNOWLEDGEMENT

First and foremost, I would like to thank my guide Prof. Chakravarthy for his valuable inputs, help and support.

I would like to express my gratitude to Mr. Satyajit Vetoskar, Design Head, VIP Luggage for his valued guidance and suggestions. I am also grateful to him for pushing me to the edge so as to put in the kind of effort that is required for such a project.

I also acknowledge the worthy suggestions from the IDC faculty and my fellow colleagues at VIP at every stage of the project. This project would have not been possible without affirmative response from VIP luggage design studio, facilities & staff.

1.Introduction

Luggage design as an industrial project with 'VIP luggage' is a project chosen to reconstruct all design learning that happened at IDC and recollecting it through direct implementation in industry. This is a six month project which started at June`07.

About VIP

'VIP luggage' is second largest luggage brand in the world and the largest brand in Asia. It is highly trusted premium brand present in the markets since 1971.It caters to multiple categories-hard & soft luggage, business bags, duffels, backpacks etc. with focus on style & quality. VIP luggage aims to provide joyful travel through thought full & innovative products. Its no wonder then, that happy journeys begin with VIP.

2.The thought (rationale of the study)

I have chosen to consider the topic 'Luggage design' as an industrial project with 'VIP luggage' which is about understanding and designing luggage which has become part of everyday life for all of us.

More I travel around, observe, analyze luggage, accessories more I am convinced that it is purely functionality and convenience that is at the core of all successful traveling or trip or journey. Being a design student, and being genuinely interested in luggage and accessory design.

I desire to learn design process that involves systematic research, planning and its implementation towards reaching a level that brings actual feasible product that is marketable and profitable as well.

Apart from redesigning and modification of existing luggage there could be new innovations and that is the very intention of this project work.

3.Objective

To design an **upright, hard/ hybrid** luggage using **Polycarbonate** as material and **Vacuum forming** as manufacturing process.

for user

sex: male and/or female

age: 25 to 35 years

personality:

- outgoing, smart
- passionate about traveling
- aware about current fashion, trends

4. Methodology

Step 1: Data collection to understand luggage

Step 2: To grasp the detailed idea of the objective

Step 3: To understand the specified user category

Step 4: Analysis and ideation

Analysis of the existing product range is done on the basis of parameters such as stance, form, colours, textures, product hardware and interiors

The product to be designed, upright luggage, is analyzed considering each of its component as a sub-entity

Ideation is done for each component to get minimum three concepts for each.

Simultaneously styling and form exploration is done to visualize bag as a whole.

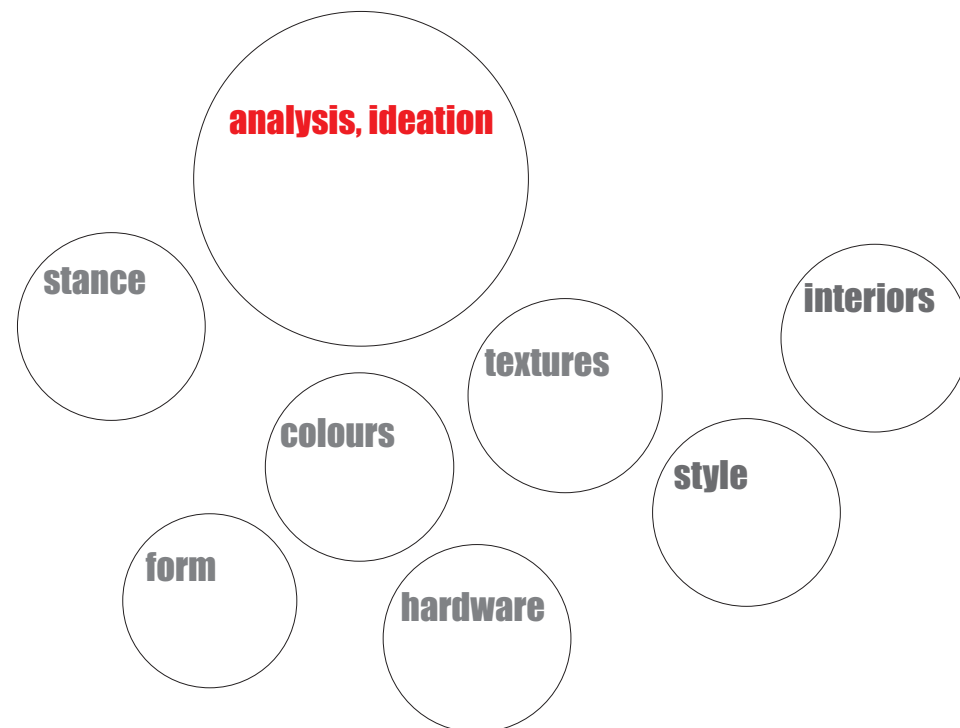

Step 5: **Product brief**

Step 6: **Concept generation**

3 concept designs are generated, such that each concept will have different concept hardware and style. Adopting idea derived in idea clusters of each component are judiciously merged together to come up with three primary concepts. These concepts are evaluated to get the best possible out of them.

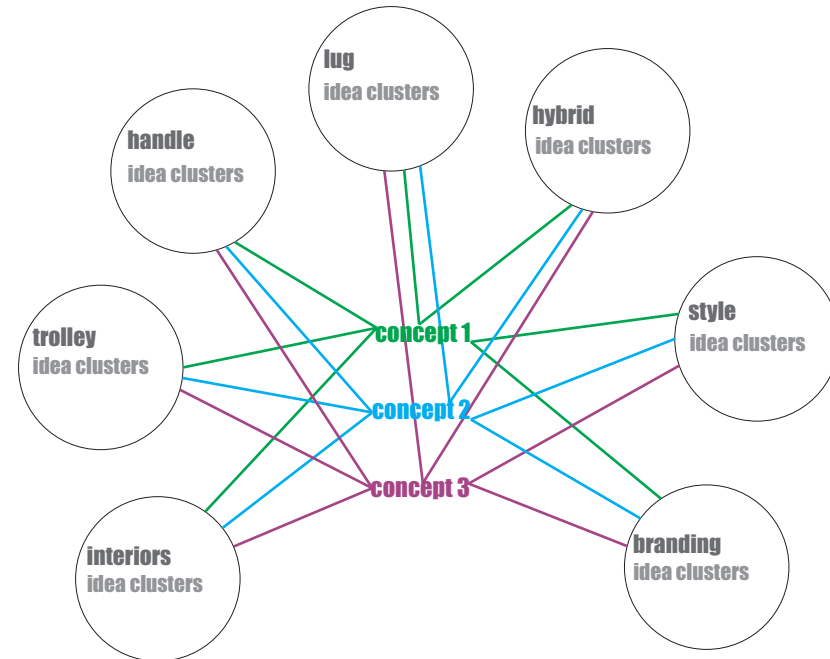

Step 7: **Final concept**

choosing the best features out of each concept to blend them together to get the final concept

Step 8: **Final concept refinement**

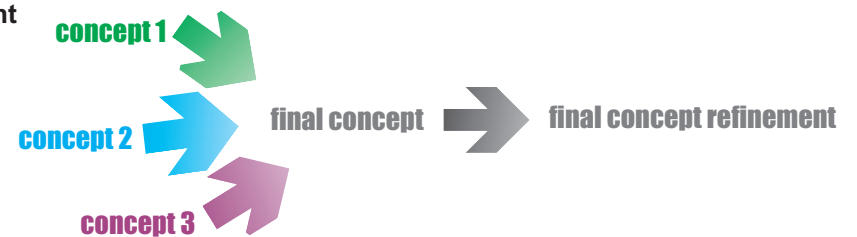

DATA COLLECTION for understanding luggage

1. Terminology
2. Types of luggage
3. Luggage accessories
4. Classification
5. Manufacturing & materials
6. Luggage & interaction

1. Terminology

the usual word for “baggage belonging to passengers

from lug “to drag”

“what has to be lugged about” or, “any thing of more bulk than value”

“baggage” is functionally related to the noun “bag,”
and luggage related to the act of “lugging.”
Baggage can be synonymous with “luggage”,

Luggage is any number of bags, cases and containers
which hold a traveler articles during transit.

luggage and the style thereof is representative of the owner’s wealth.

Luggage is any number of bags, cases and containers which hold a traveler articles during transit.
The modern traveler can be expected to have packages containing clothing, toiletries,
small possessions, trip necessities, and on the return-trip, souvenirs.

For some, luggage and the style thereof is representative of the owner’s wealth.

2. Different types of luggage



business cases



briefcase



cabin luggage



suitcase



backpack



air bags



laptop cases



messenger bag

3.Luggage accessories



travel document case



travel shoe pouch



multi organizer waist pouch



comfort neck pillow



carry on foldable



luggage security strap



anti-theft wallet



digital camera pouch



travel safe wallet



toiletry kit

4. Classification



Hard luggage is luggage manufactured by industrial process of injection molding or vacuum forming.

Soft luggage is the luggage which is stitched together using various soft materials.

Hybrid luggage is blend of hard & soft luggage, where soft material is stitched over hard skeleton or base. Some times bottom shell is hard and front shell is soft in hybrid type of luggage.

5.Manufacturing and materials

Hard luggage manufacturing and materials

Polycarbonate and ABS shells are vacuum formed, PP shells are injection molded.

A. Injection molding

Material PP-Polypropelene
lip to lip closing

Injection molded shells has lip to lip closing detail due to its dimensional accuracy stability.



B. Vacuum forming

vacuum formed shell has closing detail of either framed closing or zippered closing.



Material ABS
framed luggage

Material PC
zippered luggage

As Polycarbonate is strong impact resistant material low shell thickness is used hence the PC shells are stitch able hence zipper closing is used for PC luggage.



Soft luggage manufacturing and materials



Soft luggage is the luggage which is stitched together using various soft materials such as polyester, EVA, nylon, neoprene, PVC. Soft luggage is stitched over molded EVA or formed PVC to get the hardness and the shape

Hardware

Nylon, PP, PVC are used for manufacturing molded hardware for both hard & soft luggage.

6. Luggage & interaction

Luggage & accessories has become part of our daily life. Right from childhood to youth to professional or elderly stage of human life, there exist a human- luggage interaction.

Following **photo collages** give us hint about various types of interactions those take place



Luggage as a part of everyday life & various scenarios



Carrying luggage & various activities

Luggage & interaction

Following **photo collages** give us hint about various types of interactions those take place



Luggage as a part of everyday life & various scenarios



Carrying luggage & various activities



Luggage & interaction



Luggage as a part of professional life

Business executives, managers, young professionals working in various fields carry luggage suitable to their lifestyle. At this part of professional life luggage and the style thereof is representative of the owner's wealth.



Packing your luggage

Photo collage below represents most common type of human- luggage interaction that takes place during packing the luggage





Emotions & luggage

Luggage as a companion

Luggage we carry indirectly becomes companion during our journey. It helps us to get the feeling of having someone around or as a company.



Luggage to rest over, sit & relax



Luggage as footrest



Have u ever slept with luggage?

In emergency cases we always see people sleeping over the luggage.





Coolie`ing out with luggage



On a car trip

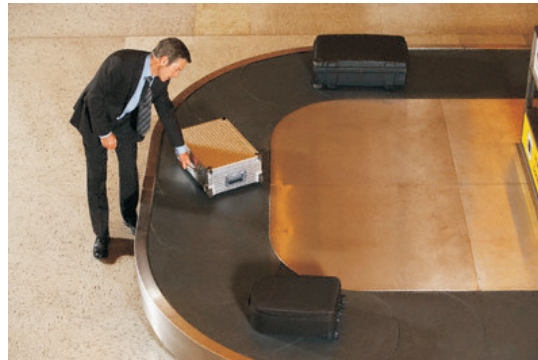

At the airport belt



Luggage & youth culture

Luggage one carries and the style thereof is representative of the owner's wealth attitude mindset and life-style.



Luggage n` fashion

APPRECIATION

1. Objective
2. User

1. Appreciating the objective statement.

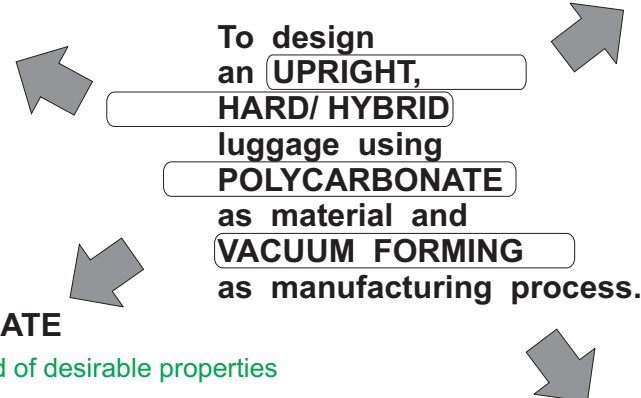

About POLYCARBONATE

- polymer with a unique blend of desirable properties
- Polycarbonate sheets provide excellent value for money and perform effectively for years with minimum maintenance
- various finishes, colours, textures possible
- can be translucent or transparent
- high impact resistance
- light weight
- expensive

About VACUUM FORMING

- cost effective process for batch manufacturing
- uniform thickness
- rough edge details
- less definition for the form

Additional information

Other essential details those contribute towards better understanding of objective statement

About the luggage:

unisex version

not any particular location or culture specific

size 55cm cabin size or 65cm

Journey: 3-4 days of journey

Mode of transport:
By air or by higher class railways

2. Understanding the user

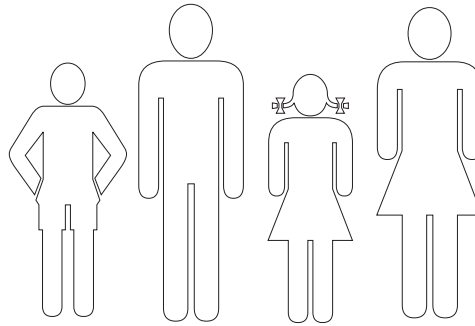

sex: male and/or female
age: 25 to 35 years

Personality:

- outgoing, smart
- passionate about traveling
- aware about current fashion, trends

User profession possibilities: user can be artist, designer, into creative work like advertising can be into marketing or can be post graduate student etc.

Financial status: middle class or upper middle class, uses his money smartly, opts for value for money products

Understanding the user

How many days of travel?
3-4 days approximately

what all he(considering)carries?

Following are the list of things out of which a typical mentioned user will carry some, according to his area of interest or profession & life-style.

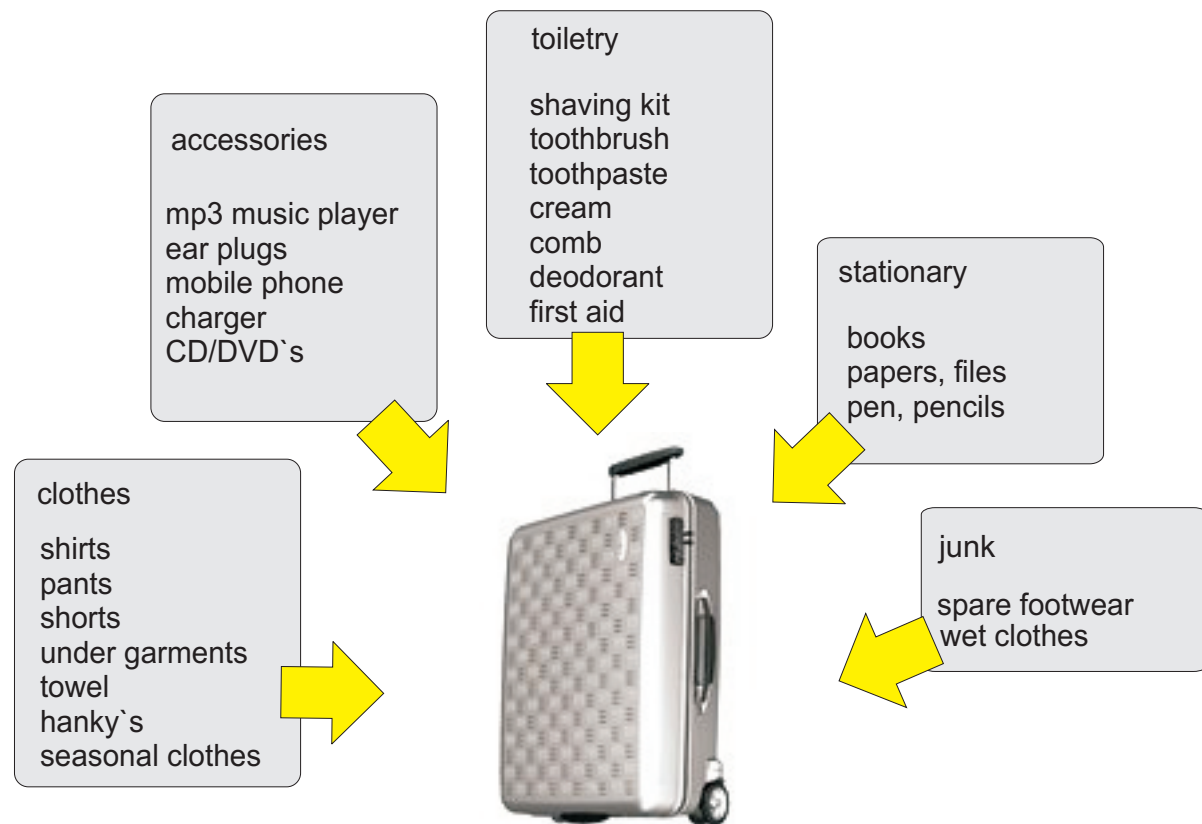

Understanding the user

considering me as one the prominent users:

what all I'll carry for 3-4 days of travel, over a trip that looks semiformal. Considering the scenario where I am traveling to Pune where I have some design work regarding my project and after that I am planning to attend musical concerts and I m going to stay at my friends farm house near Pune for a couple of days. I am going by train and details for my journey to back home are yet to be decided.



ANALYSIS & IDEATION

1. Upright stance & form
2. Upright colours
3. Upright texture & finish
4. Upright sizes
5. Upright components
6. Trolley
7. Wheels
8. Lug
9. Handle
10. Lock
11. Interiors
12. Pullers
13. Hybrid variation
14. Visualizing bag as a whole

Analysis of the existing product range is done on the basis of parameters such as stance, form, colours, textures, product hardware and interiors.

The product to be designed, upright luggage, is analyzed considering each of its component as a separate sub-entity

Ideation sketching is done for each of this component to get minimum three concepts for each.

Simultaneously styling and form exploration is done to visualize bag as a whole.

1. UPRIGHT STANCE & FORM

**Observation / Analysis**

Taking look at most of the uprights available in the market, there is bit of the variety among soft uprights. Hard upright luggage is much monotonous and plain that reflects association with suitcases regarding form and stance.

Each detail like groove, bulge you have on the outer profile eats space inside or makes inside profile irregular but adds strength to the shell specially in case of vacuum forming. Hence such details should be judiciously imparted to the design.

Scope / Insight

Form of the upright should visually convince the user, customer that there is big space inside to keep maximum luggage at the same time it should not make it look like heavy or bulky. So there has to be equilibrium regarding these factors.

Hybrid upright luggage to be designed can have nu`age stance that portrays, on the ground rooted character at the same time form can be such that it makes it dynamic & youthful. Simple details like grooves, chamfered profiles will be interesting to try out.

2. UPRIGHT COLOURS



Observation / Analysis

Above is the spectrum within in which the upright luggage colour variation that has successfully catered the users. Dark colours shows off dust, dull colours shows off scratches.

Scope / Insight

Hybrid luggage will certainly give scope to experiment ,tryout colour combinations. Bottom shell which will is more prone to rest on ground can have darker shade as compared to front shell. Bottom shell can be manufactured in fixed dark shade and front shell colours can be varied to get different combinations and to save the cost.

3. UPRIGHT TEXTURE & FINISH

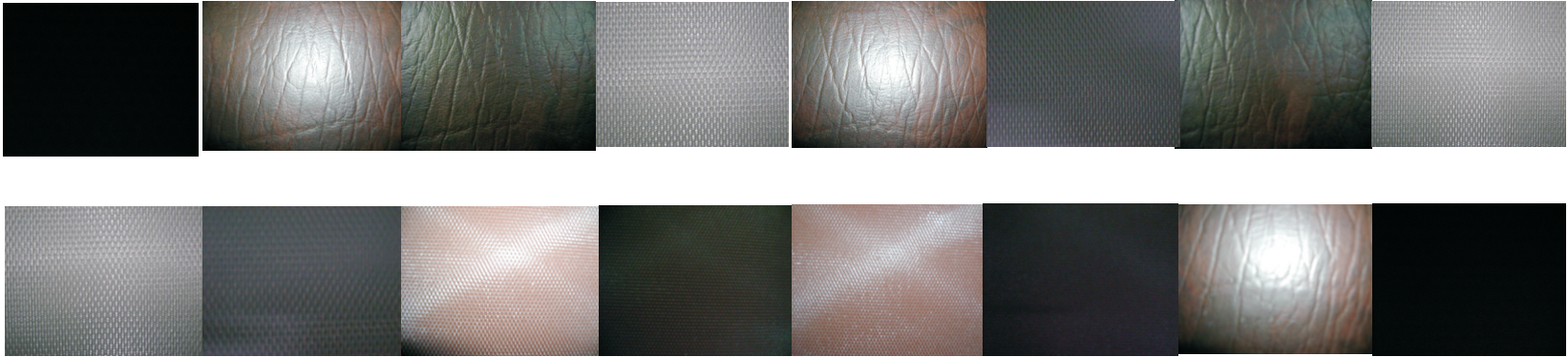
**Observation / Analysis**

Glossy, mirror finished luggage stands out and is preferred sometimes but it shows off dust and scratches. Matte finish is used in most of the luggage so as to make it more convenient to maintain.

Scope / Insight

Textures adds to the visual appearance of the luggage also makes it strong

Hybrid design has scope where one can have matte finish for the back shell as it rests on the ground while packing, the front shell can have combination finish or texture variation.

Polycarbonate has very wide range of textures and finish possibilities using it judiciously will enhance the visual appeal of the luggage.

4. UPRIGHT SIZES



55 65 75_{cms}



55_{cms}



Observation / Analysis

Generally you get similar design of the luggage in various sizes 55cm, 65cm,75cm, air-bag size
 55 cm is referred to as cabin size luggage as that is the maximum allowable height for the luggage one can carry and fits in the cabin storage during air travel.

Scope / Insight

While designing hybrid upright luggage its convenient to consider cabin size as preliminary size to start with.
 after successfully designing cabin size upright similar design considerations will be adopted for various other sizes

One more interesting point for cost reduction is, same hardware is used for different sizes of the same design.
 So handle size will be same(same handle will be used) for 55cm bag and 65 cm bag.

5. UPRIGHT COMPONENTS



Observation / Analysis

The product to be designed, upright luggage, is analyzed considering each of its component as a separate sub-entity. Ideation sketching is done for each of this component to get minimum three concepts for each. The typical upright has following components

- | | |
|-------------|--|
| trolley | lock TSA lock |
| wheels | interior |
| lugs | closing detail- zipper closing, framed closing, lip to lip closing |
| top handle | pullers in case of zippered closing |
| side handle | additional accessories |

Scope / Insight

Its not mandatory to have all of these components, a smart design might reduce need for one of these components this will further reduce overall cost.

6. TROLLEY

Observation / Analysis

Interaction



Gives option of mounting axillary luggage on the bag resting on the trolley stem



Makes it very easy to carry heavy luggage



No space given around the trolley handle to make it easy comfortable grab



From the top view you can see two lifting handles

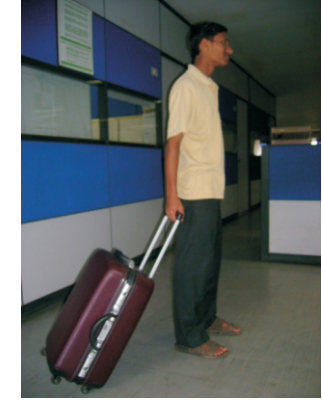
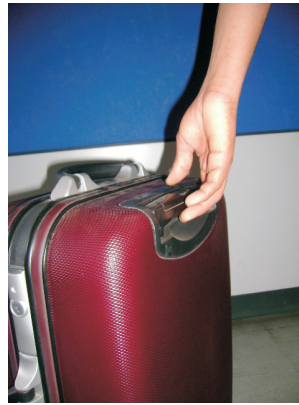

User needs to change wrist position and hand orientation during the whole interaction of pulling out or pushing down the trolley

TROLLEY

Observation / Analysis



single stem trolley



double stem trolley



if trolley is outside the bag there are chances of it getting damaged due to mishandling



trolley makes luggage heavy



various sizes



mechanism



interior of the bag look uneven due to trolley inside this makes problem for packing the luggage occupies inside volume of the bag



single stem trolley

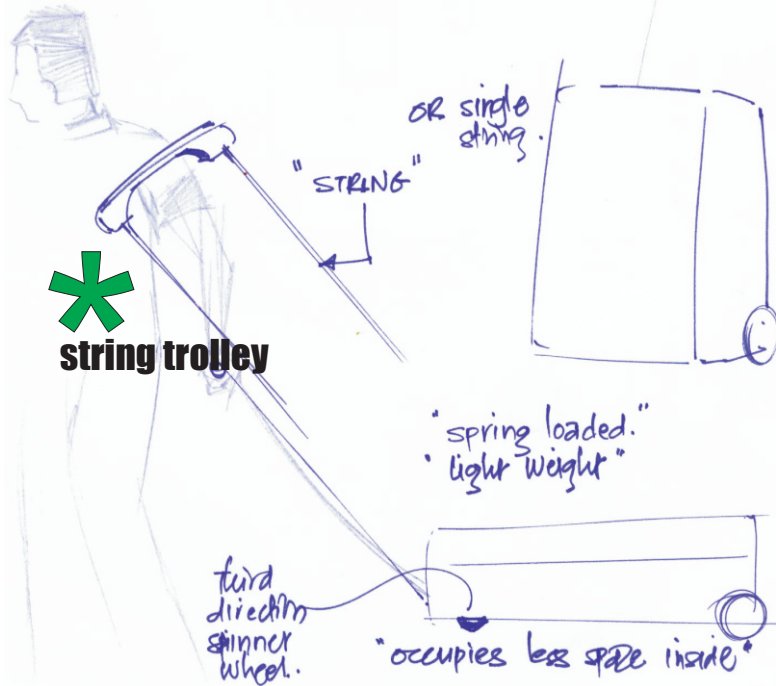
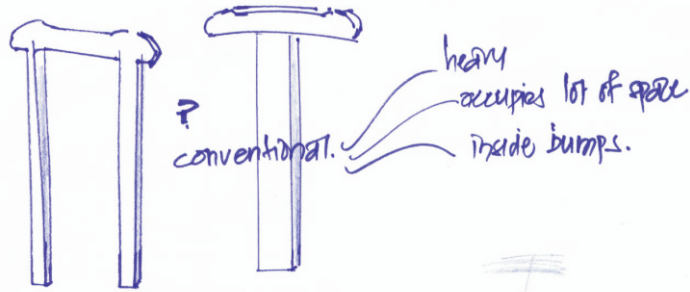

string trolley

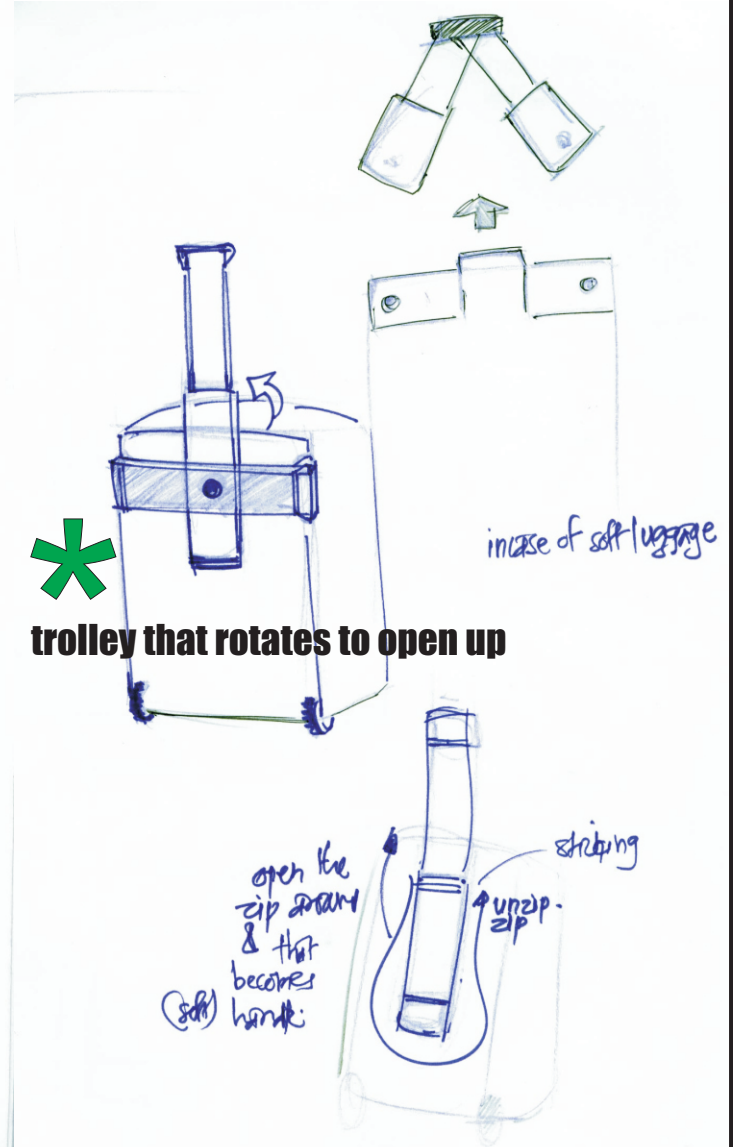

trolley that rotates to open up

Scope / Insight

Ideation sketches

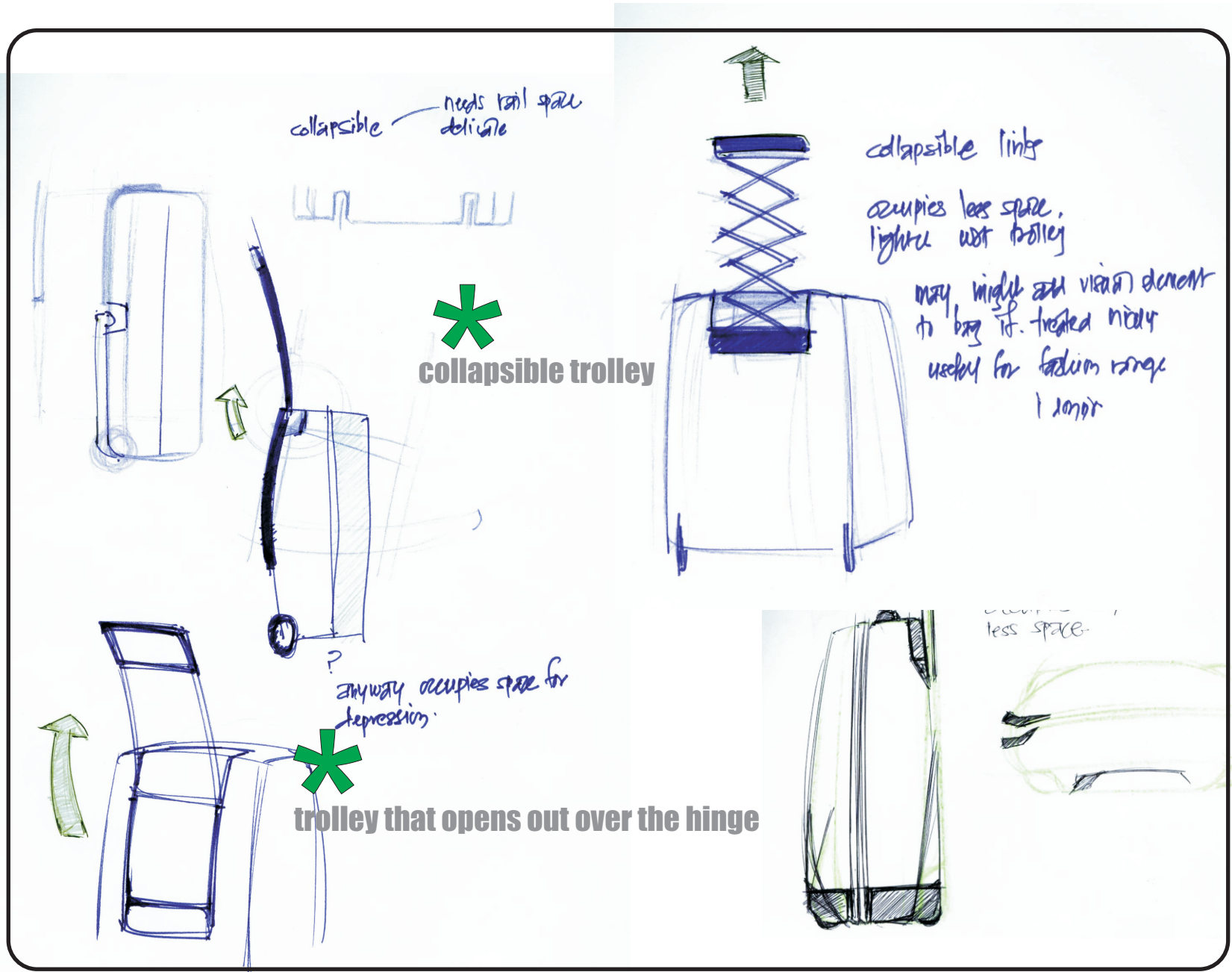

Scope / Insight

Ideation sketches



trolley projecting out of the surface yet fitted from inside

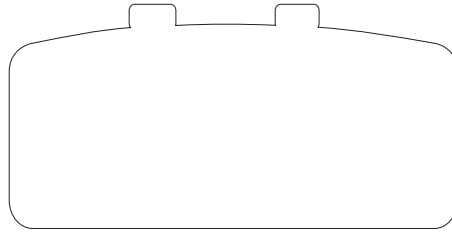

trolley integrated with top handle

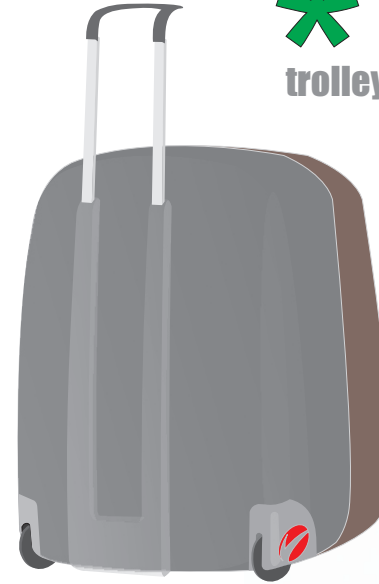

trolley with different objectives

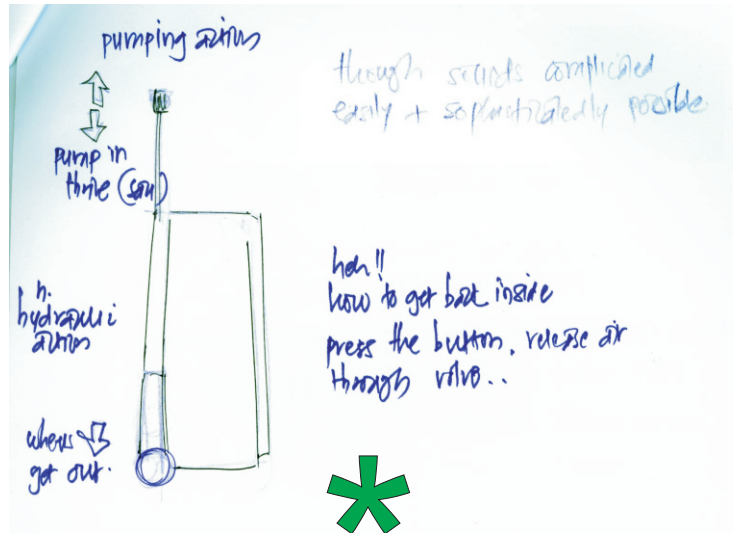

trolley integrated with other functional possibilities

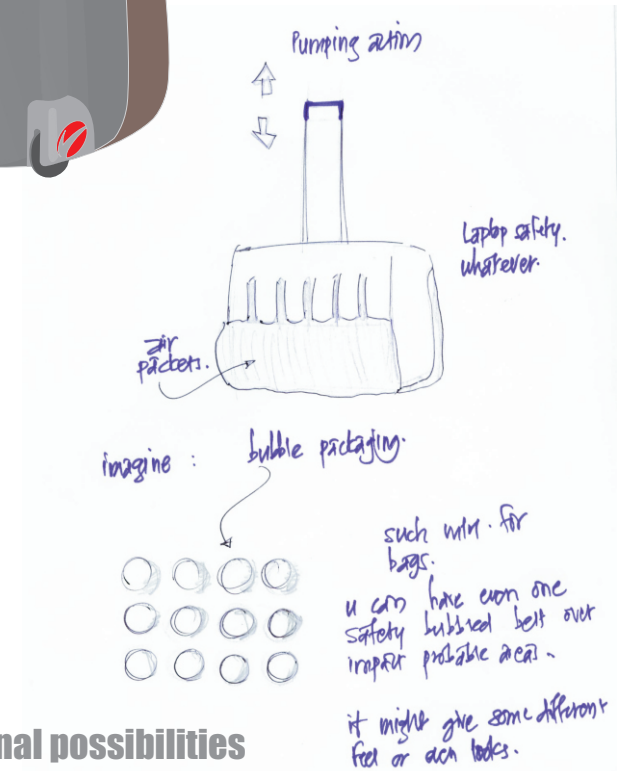

Scope / Insight

Ideation sketches

*** trolley+ wheels+back console**

*** trolley with different mechanism**

*** v- frame trolley**

*** trolley + small detachable bag**

*** trolley+bag cover**

*** trolley integrated with other functional possibilities**

*** trolley + safety belt**

regular botkey

projecting catch to hold it at position. thank!!

magnet here will reduce or chuck out whole mechanism. so that it stays at the position.

press

molded component that has safe belt bag cover

cover

SAFE SAFE SAFE

7. WHEELS

Observation / Analysis



Observation / Analysis

Normally wheel diameter for hard luggage is 9cm or even more than that.

Canopy or socket that holds the wheel together with bag consumes additional space

Wheels occupy space inside the corners

Wheels projecting out of the profile of the bag has possibility of getting knocked off or they get damaged

Wheels add to the total weight of the luggage hence they should be light weight, slick but sturdy enough to sustain large weight and volume

Scope / Insight

Wheels should be noiseless and smooth

Most of the uprights have two wheels but some designs do have four wheels, these designs have two wheels on the front which can rotate 360 degrees.

Scope / Insight

Ideation sketches

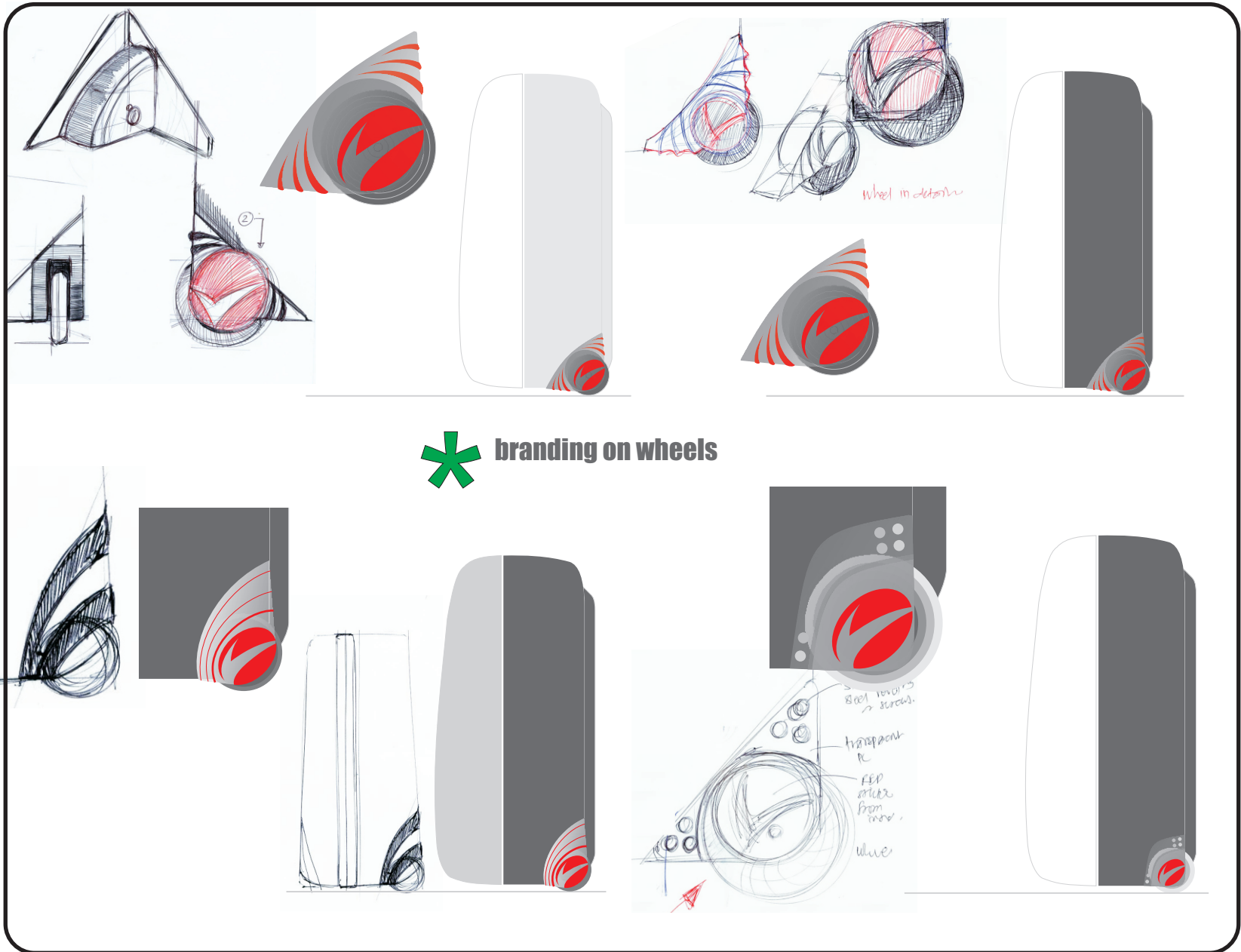

Scope / Insight

Ideation sketches

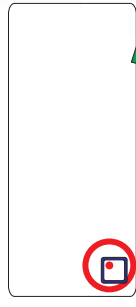
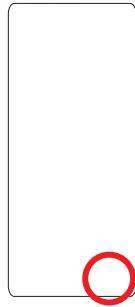
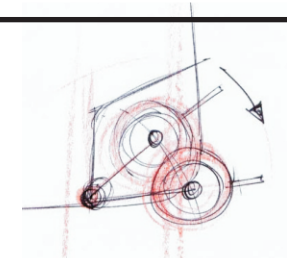
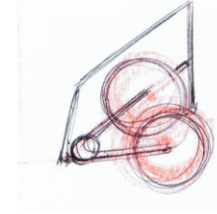
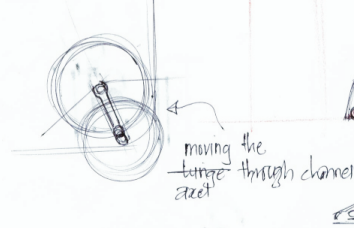
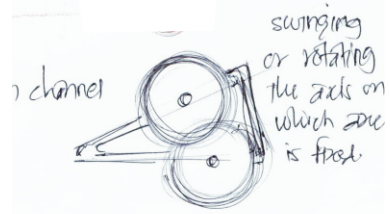

projecting out wheels

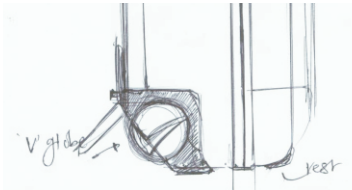

functional when inclined type of wheels

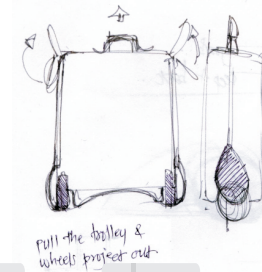
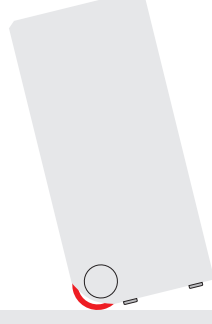
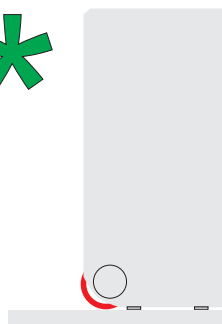

flip open wheels

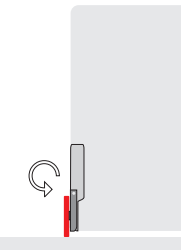
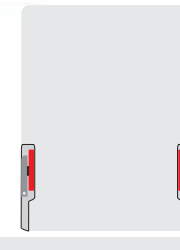
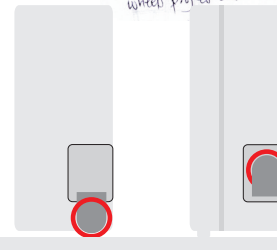
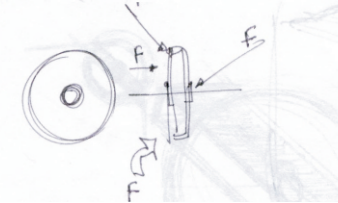

Scope / Insight

Ideation sketches

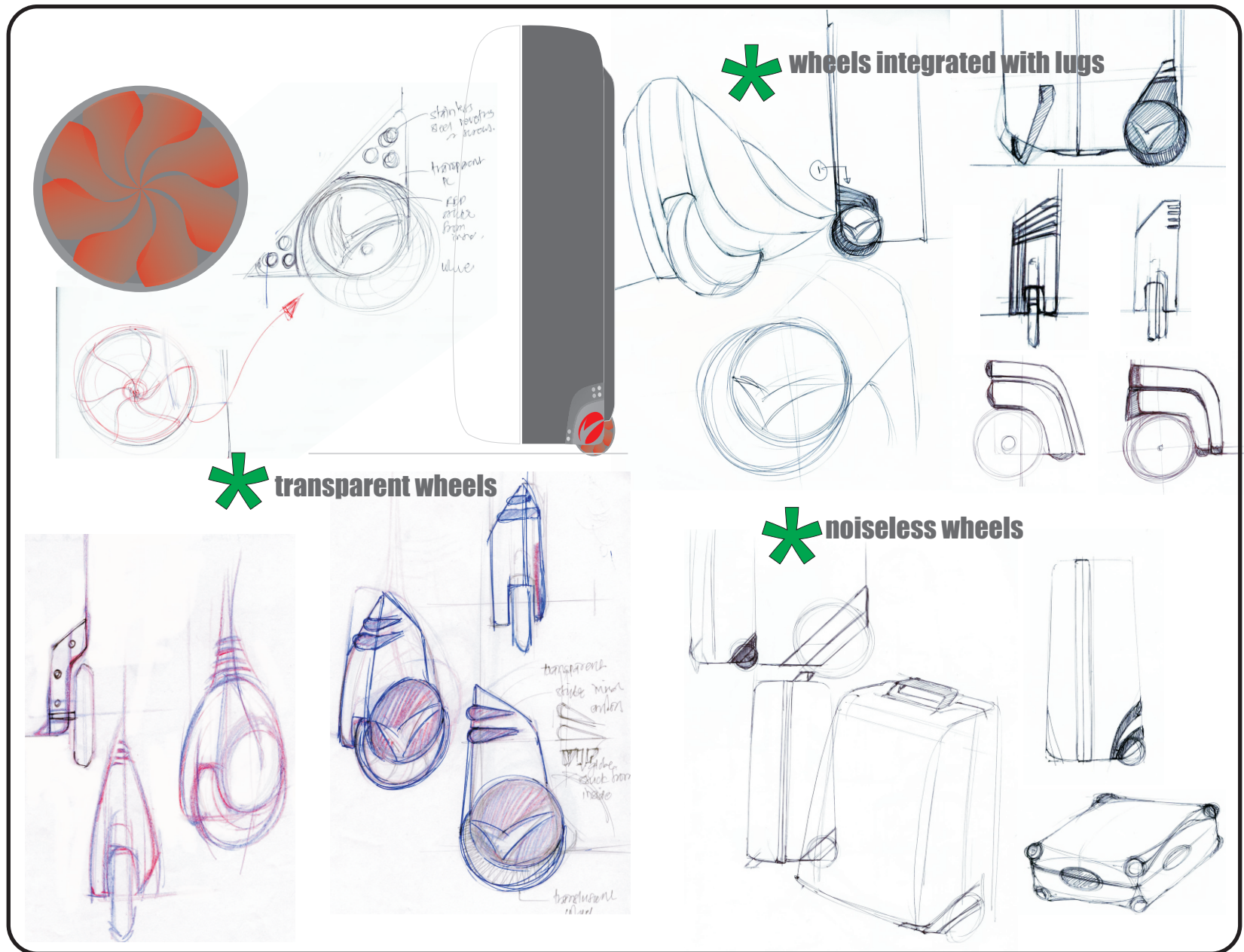

Scope / Insight

Ideation sketches

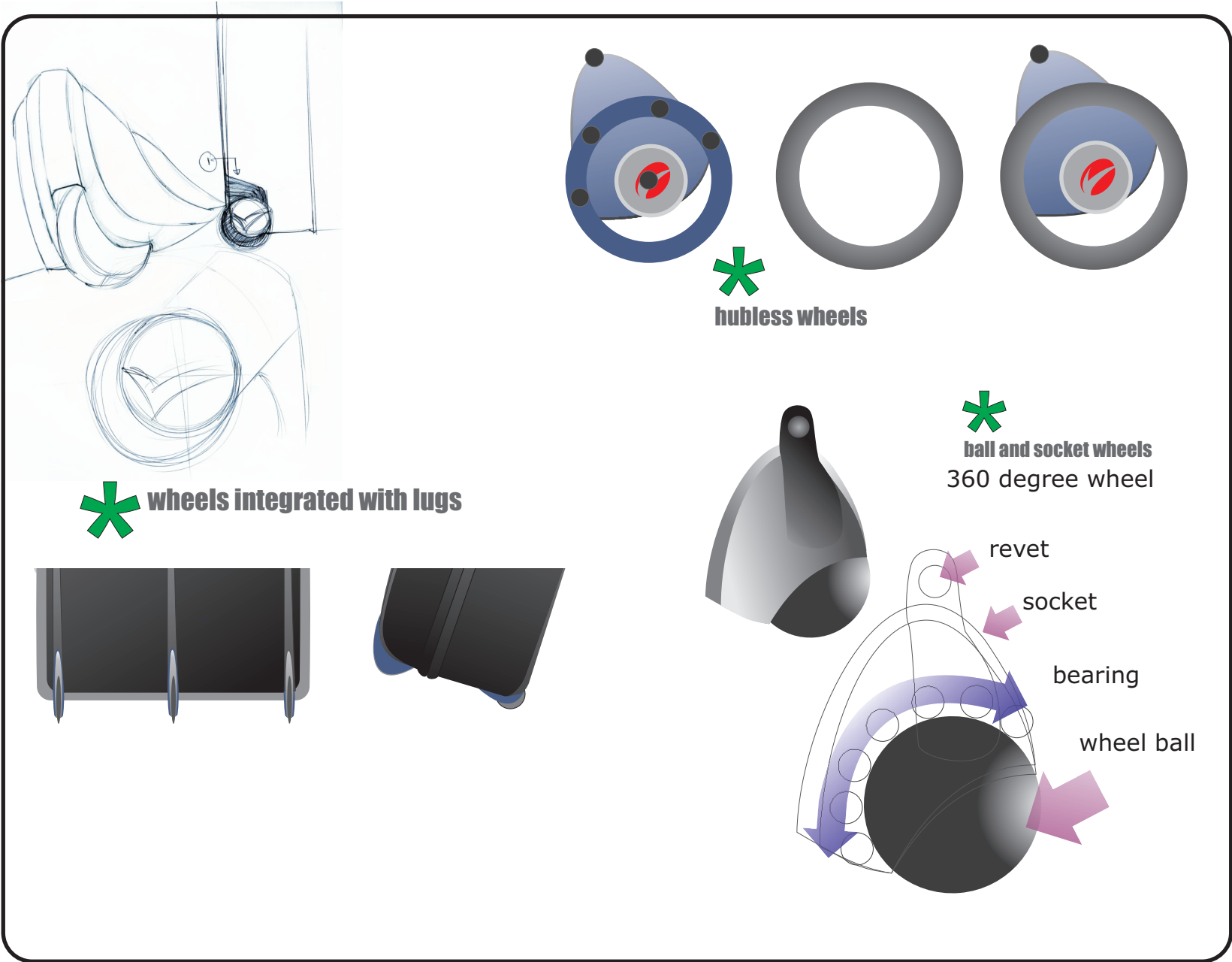

8. LUGS

Observation / Analysis

Scope / Insight

Ideation sketches

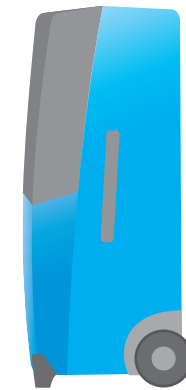
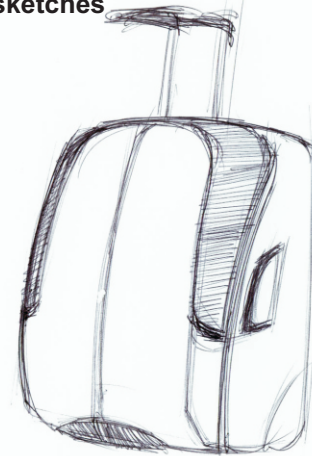
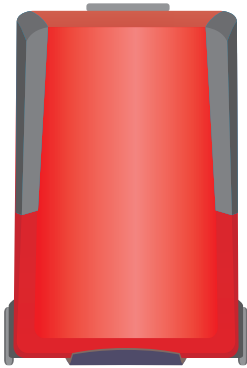

* single lug at the centre

* metallic lug

LUGS

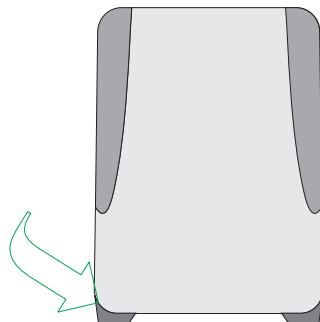

one or two number of lugs depending on the style/design

styling blends with the main styling of the bag

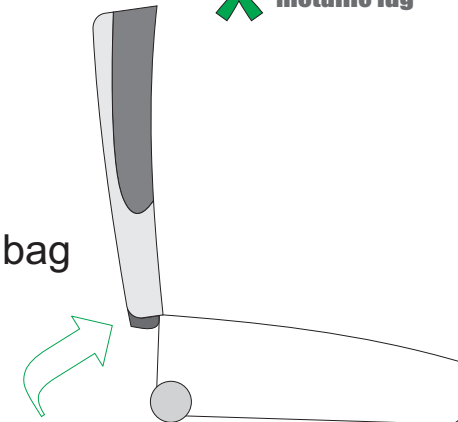

lugs will rest on the bottom shell wall when bag is opened this will keep front shell of the bag vertical in open position.

Scope / Insight

Ideation sketches

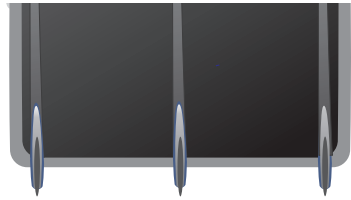

* three lugs



* lug integrated with wheel



GRAVA
GRAVITY IS LAW. OBEY IT



* loop lug

lugs will be hollow hence they will help during lifting the bag to keep into the cabin

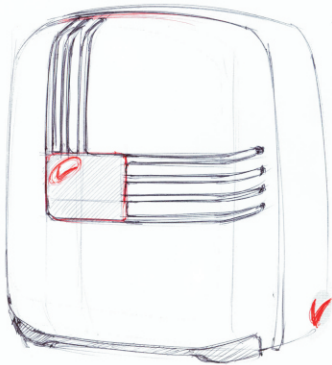

* metallic lug

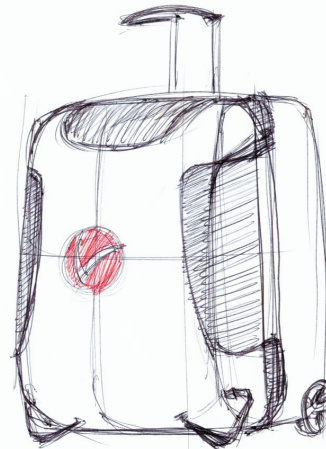
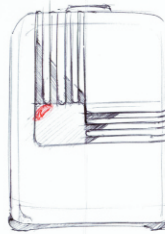

metal or nylon lug fitted with rivet

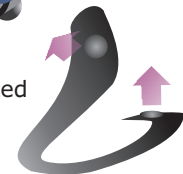

9. HANDLE

Observation / Analysis



Side handle is also provided to an upright as lifting upright entirely with the top handle is not convenient as with side handle.

In fact top handle is very rarely used and hence some of the uprights even don't have top handle

Side handle is used to lift the luggage and put it over cabin or carrier

Side handle is useful to lift the luggage when one has to walk the stairs or at places where luggage can't be rolled over wheels.

Makes luggage asymmetrical with handle on one side and lugs on the other side

Position of the handle to make it comfortable lifting of the luggage centre of gravity and the lifting point should be colinear.

If handle projects out of the surface the chances of getting it damaged.

To avoid this retractable handle are used which slides out when you hold them

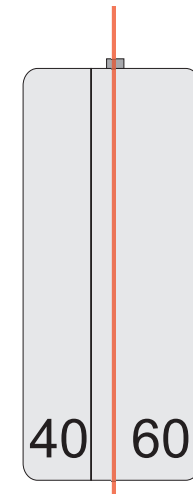

Scope / Insight

Ideation sketches

* top handle integrated with trolley handle

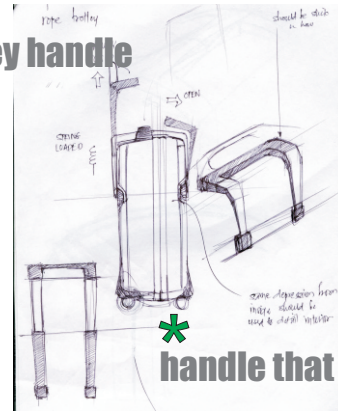
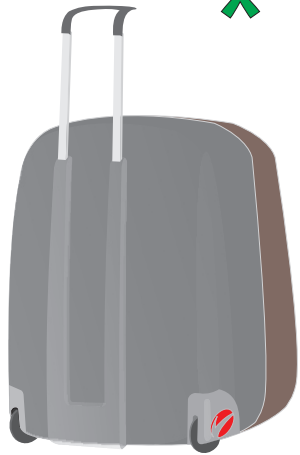

* handle that lifts luggage as

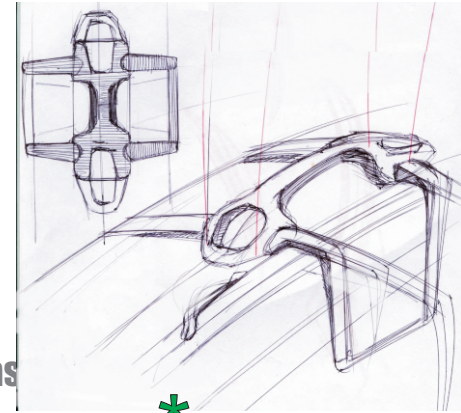

* handle + locking

* loop handle

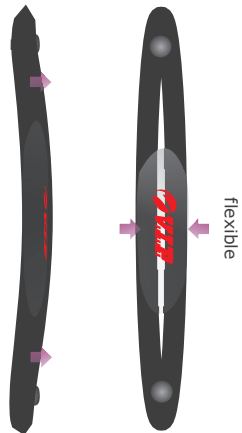

* retractable handle with different mechanism

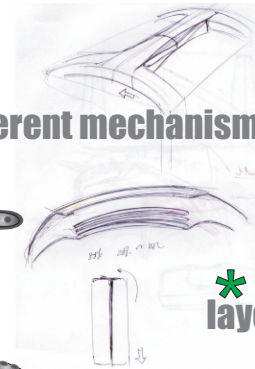
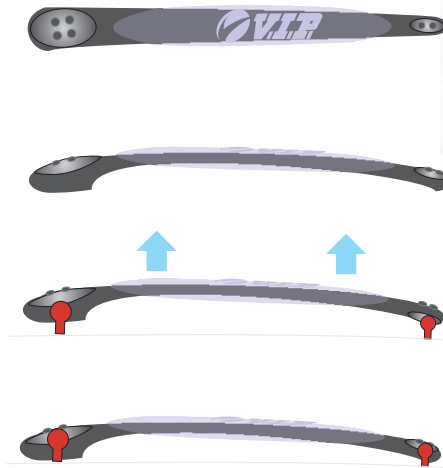

* layered handle

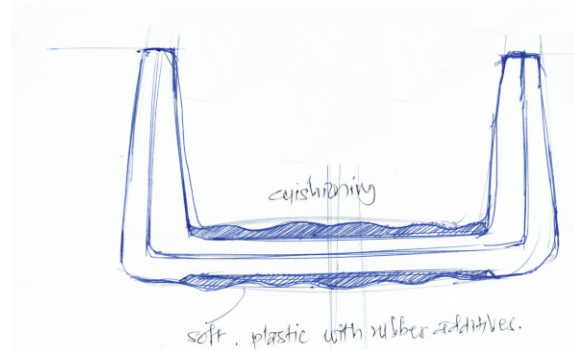

Hinge

Observation / Analysis

upright luggage has hinge on one of its sides

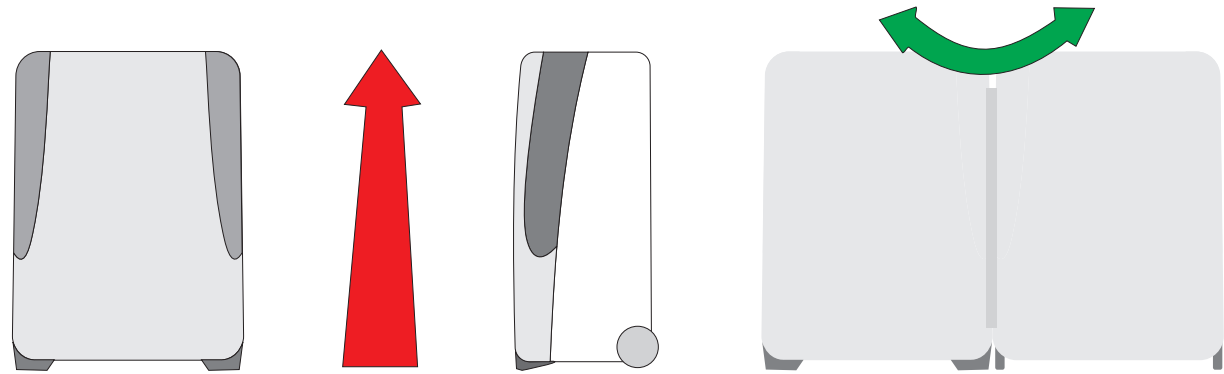

upright luggage has book opening where it entirely opens like a book and rests over ground

hinge at the side

Scope / Insight

Ideation sketches

there is a possibility where upright luggage has hinge at the bottom

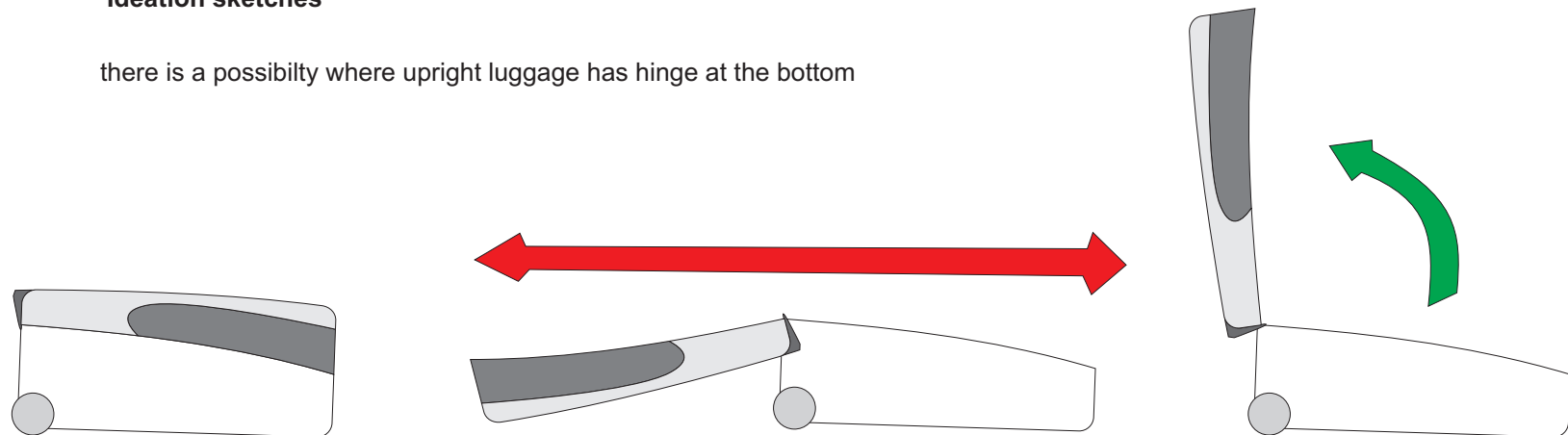

hinge at the bottom

10. LOCK

Scope / Insight
Ideation sketches

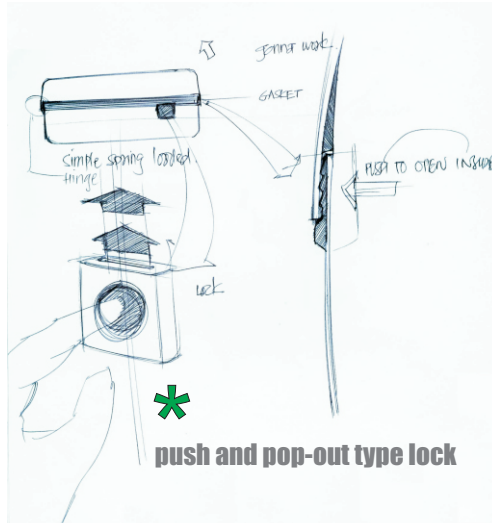

push and pop-out type lock

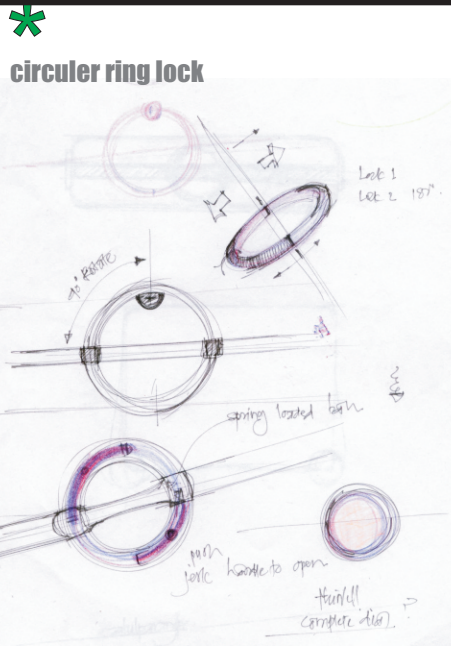

circular ring lock

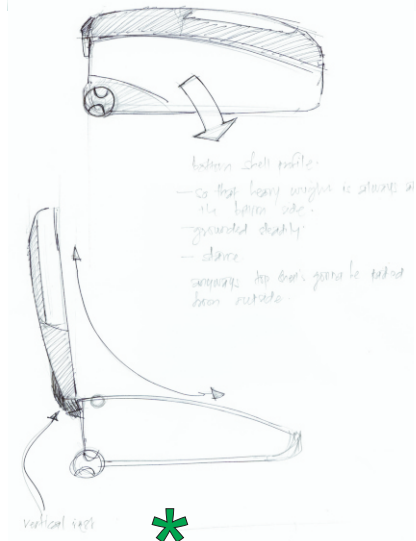
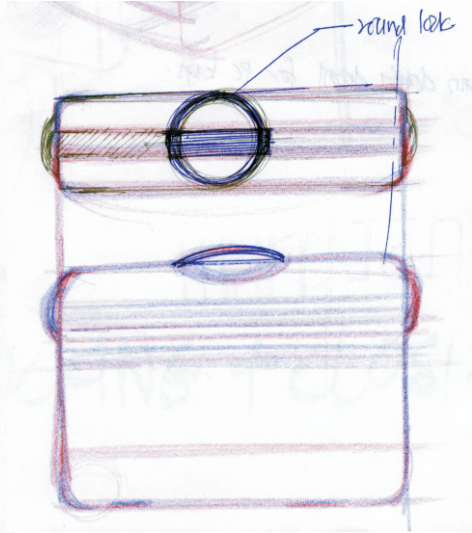

circular TSA lock

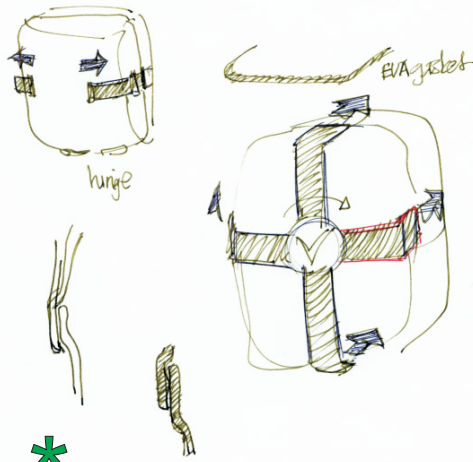

quadrant lock

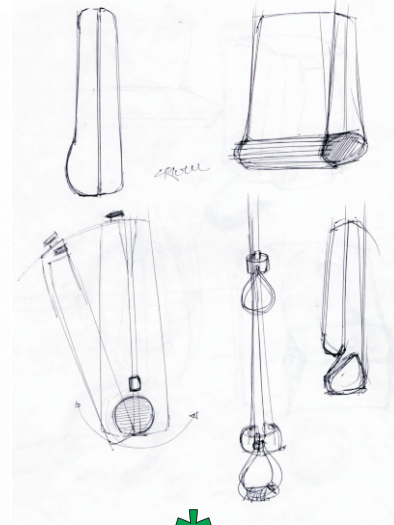

slide over lock

11. INTERIORS

Observation / Analysis



Interiors are one of the most important factors of the luggage design
 Interiors should be as simple as it is so that it lets user pack maximum
 stuff efficiently and systematically

Scope / Insight

Ideation sketches

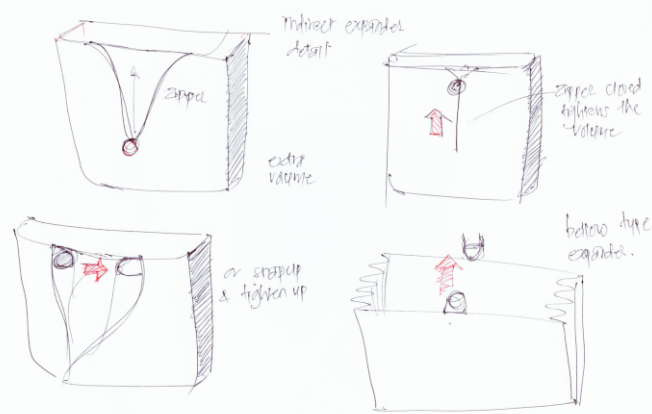

*
expander detail

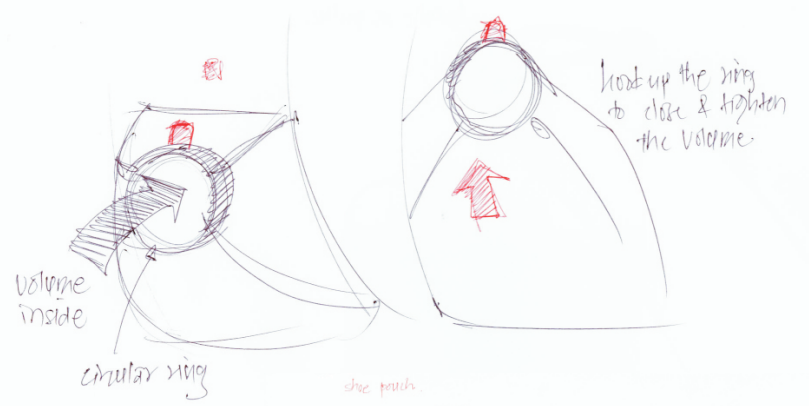

*
junk bag

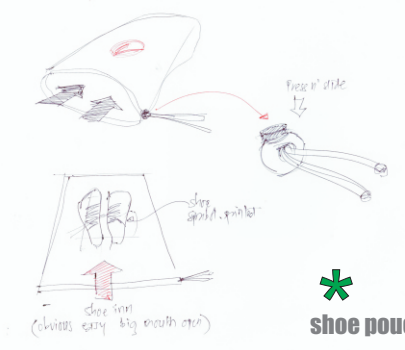

*
shoe pouch

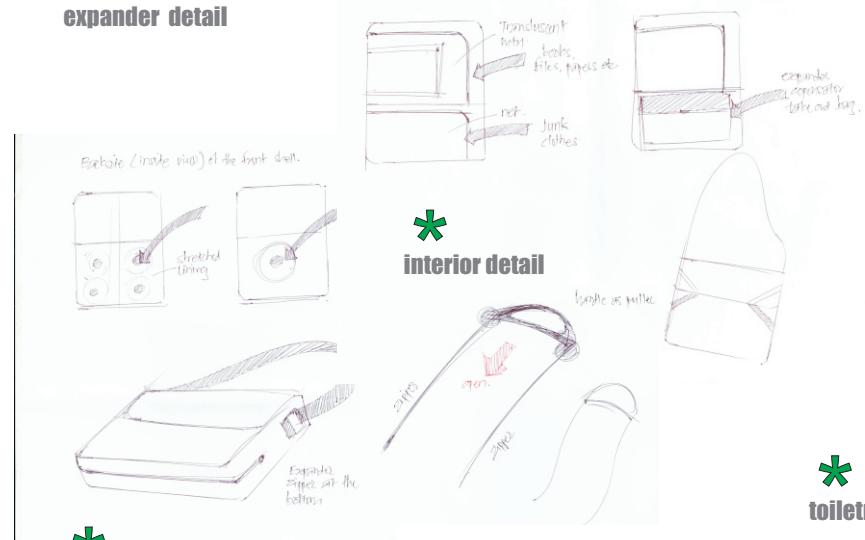

*
interior detail

*
interior detail

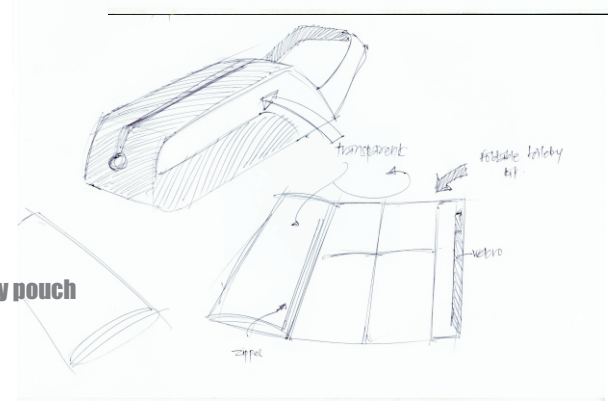

*
toiletry pouch

Scope / Insight

Ideation sketches

Bag is packed in horizontal position & carried in vertical. so clothes inside fry and slide over each other.

Vertical divider can solve this issue!

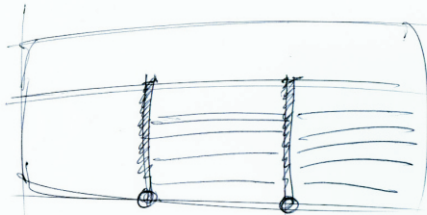

attached to the trolley stems.

* packing aid

* compartment

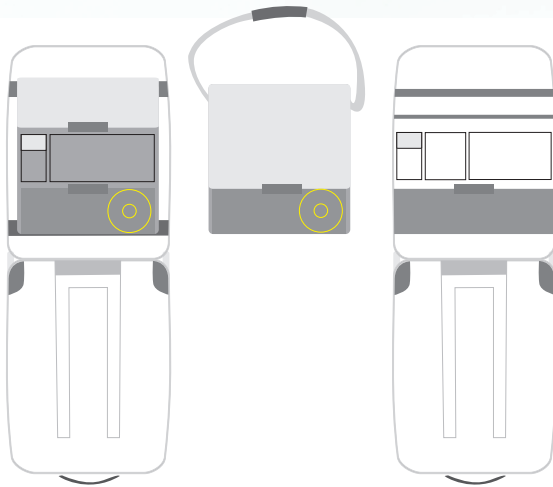
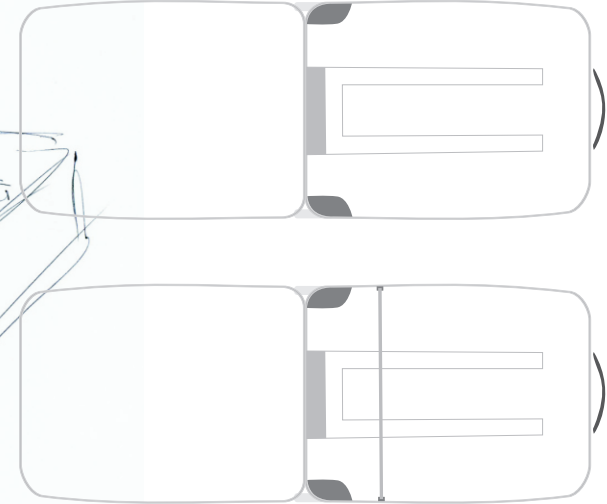
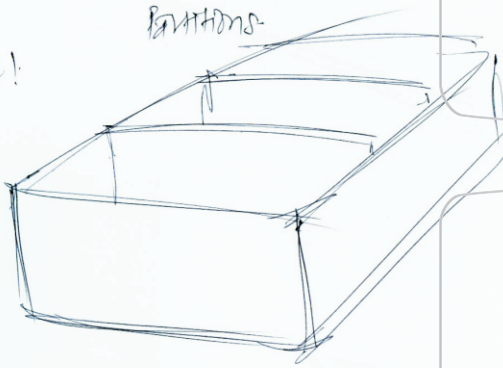

* expander compensator take away bag

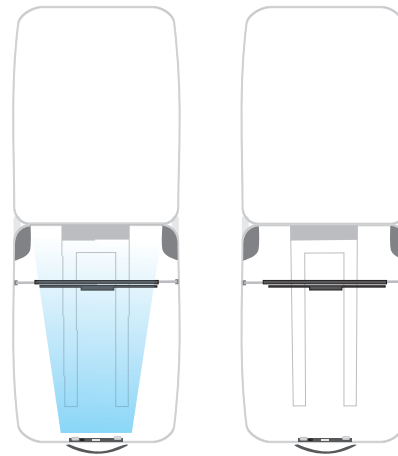

* LED light inside bag

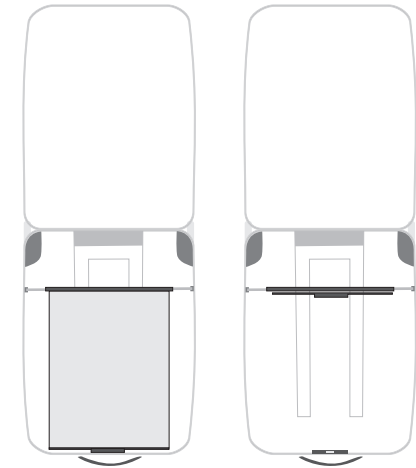

* Layered packaging aid

12. PULLERS

Scope / Insight

Ideation sketches

*** INTERLOCKING PULLERS**

*** PULLER REST**

*** PULLER INTEGRATED WITH LOCKING**

concept III Bag with the hybrid front shell.

note: allows user to access necessary stuff during the journey without the need for actually opening the bag.

*** BIGGER SIZE ERGONOMIC PULLER**

*** ANGLED PULLER**

*** YELLOW ARROWS**

TSA lock: hybrid front shell allows TSA lock to be on soft part that blends with the profile.

Scope / Insight

Ideation sketches

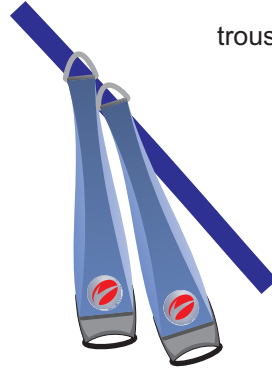

*** REVERSE TROUSER PULLERS**
trouser pullers that has flip-up and lock feature

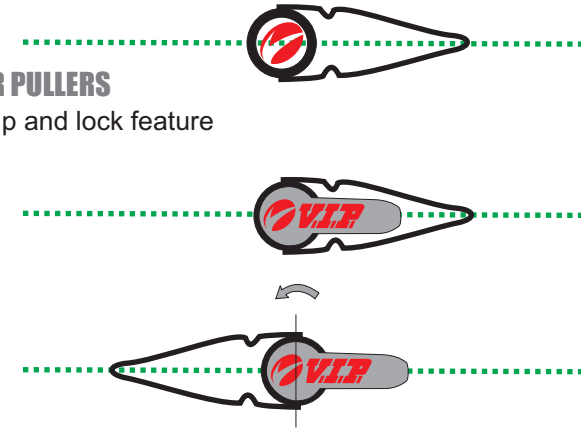

pressing the loop puller while opening the zipper makes it more comfortable and smoother operation

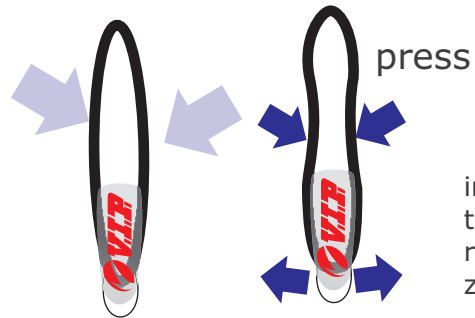

increases the tolerance and frees runner to travel over zipper

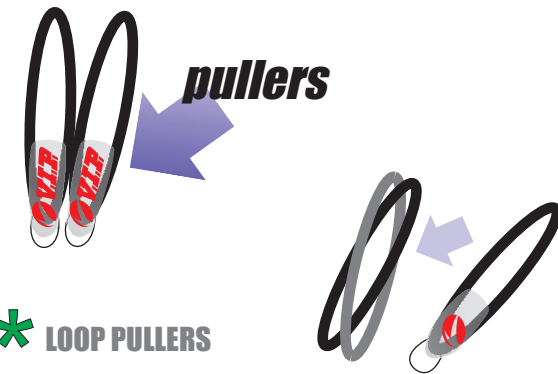

*** LOOP PULLERS**

puller get entangled so they don't make irritating noise

13. HYBRID FRONT SHELL VARIATION

variations possible in the hybrid front shell according to the utilization of the shell volume and the access to it.

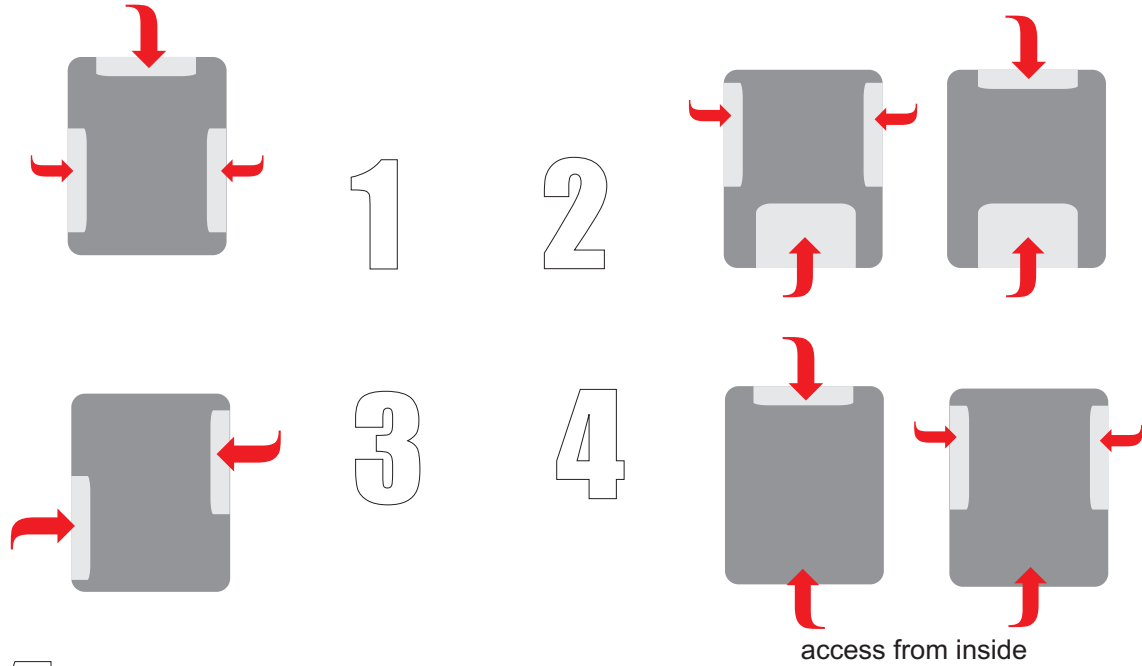

4 option 4 variations are tried out & actually made in a shell

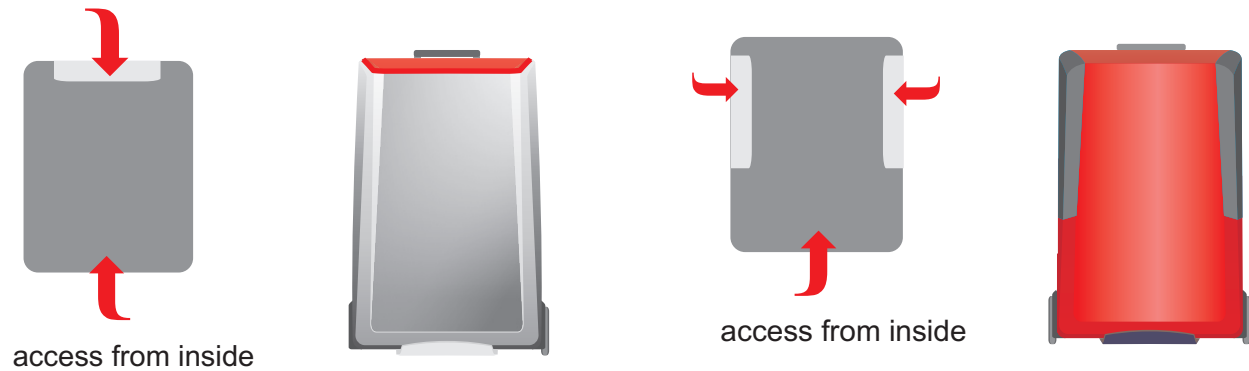

14. VISUALIZING BAG AS A WHOLE

VISUALIZING BAG AS A WHOLE

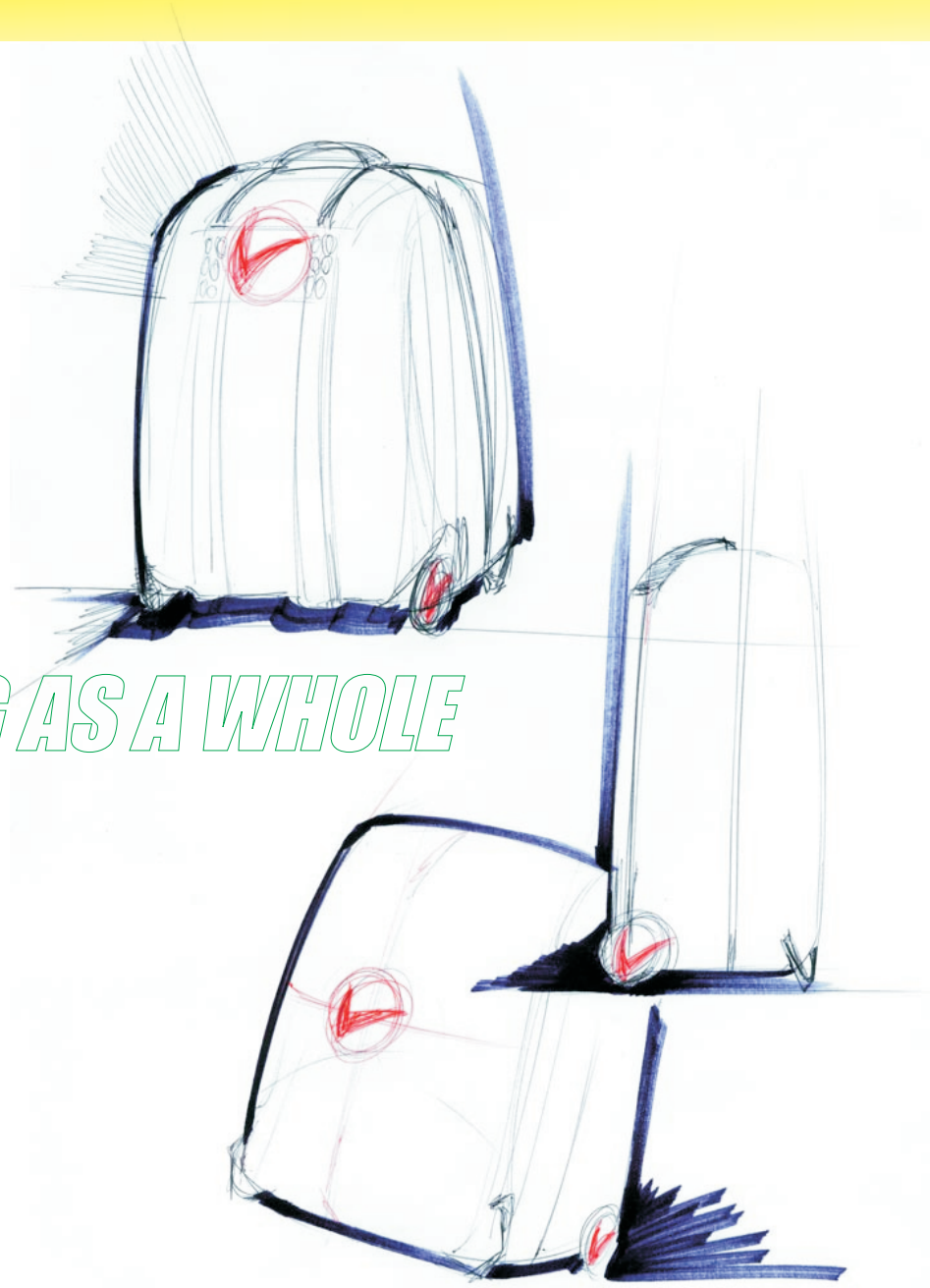

VISUALIZING BAG AS A WHOLE



GRAVA
GRAVITY IS LAW. OBEY IT



Savor

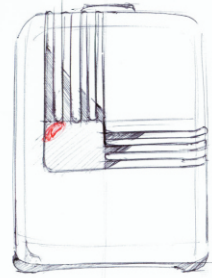
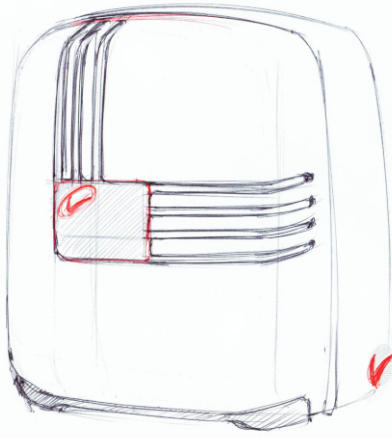

viola viola

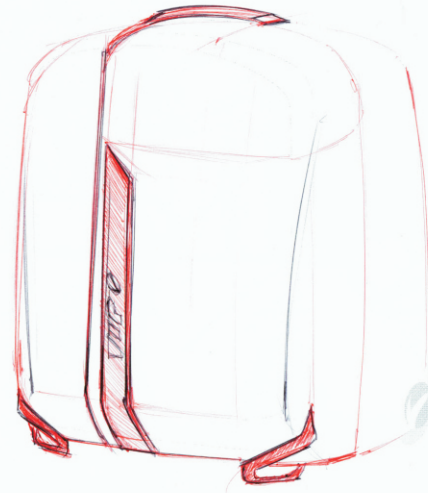

VISUALIZING BAG AS A WHOLE



VISUALIZING BAG AS A WHOLE

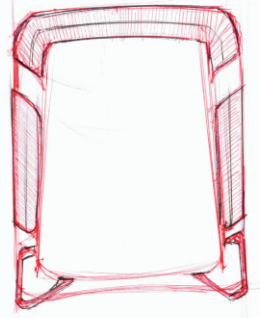
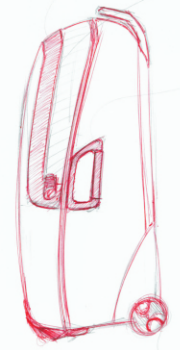
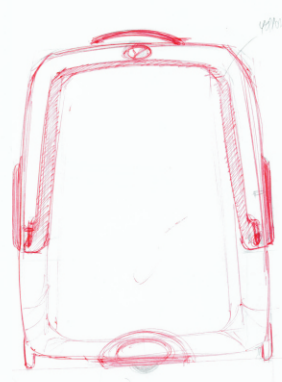
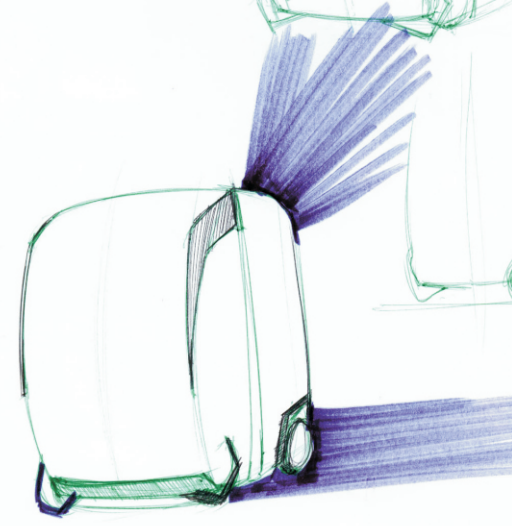
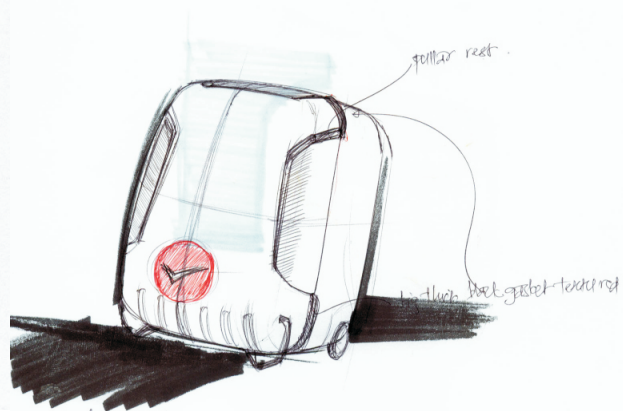
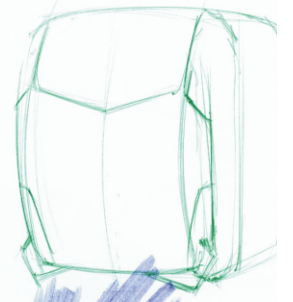
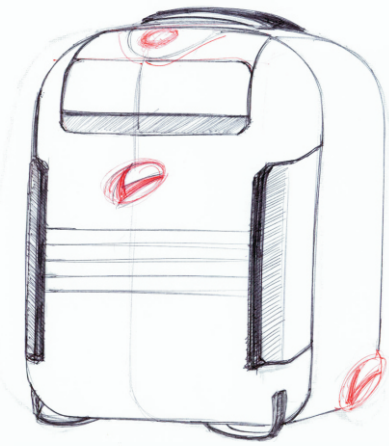

two handles of both sides:
left side as handle + side lug.

yellow
elaborate

VISUALIZING BAG AS A WHOLE

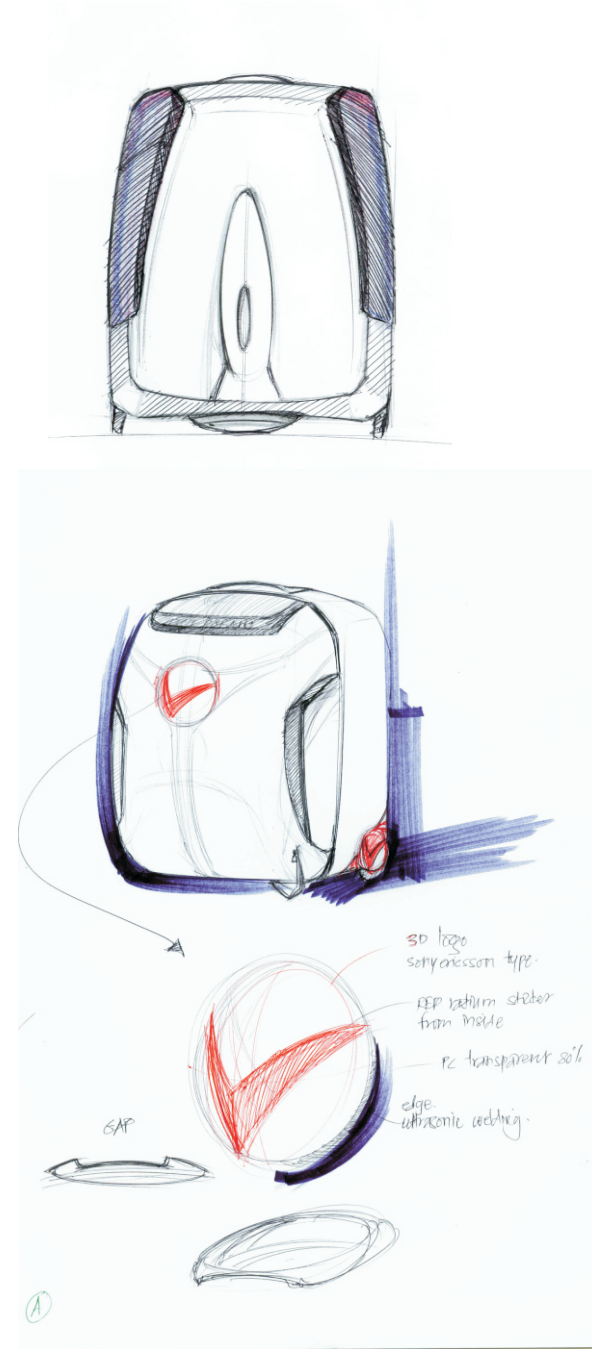



VISUALIZING BAG AS A WHOLE

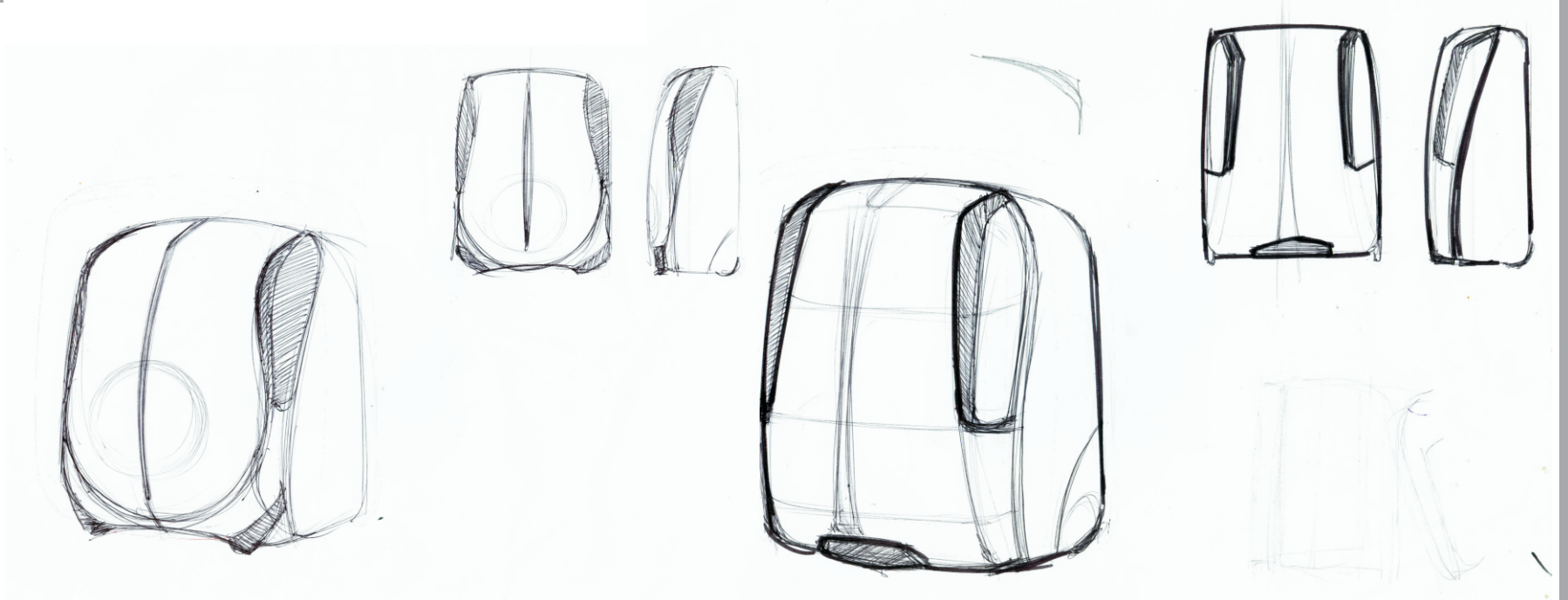
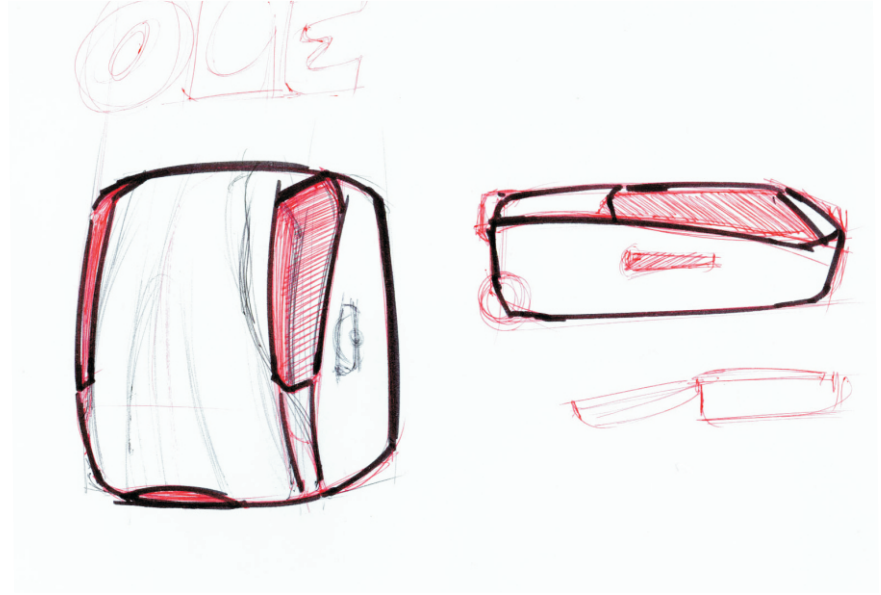

PRODUCT BRIEF

Product brief further narrows down the design parameters. Possibilities regarding each component is stated & followed to help the process of concept generation

stance orientation & size

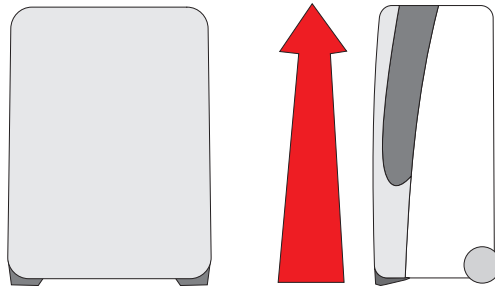

absolute vertical

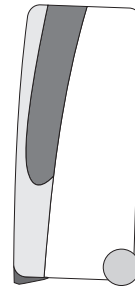

hinge at the bottom

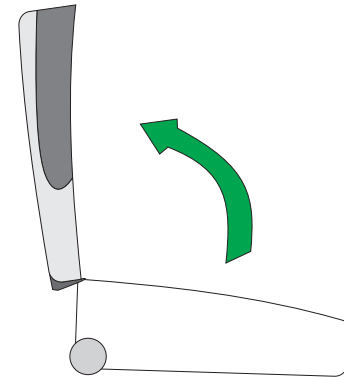

opens and stands vertical

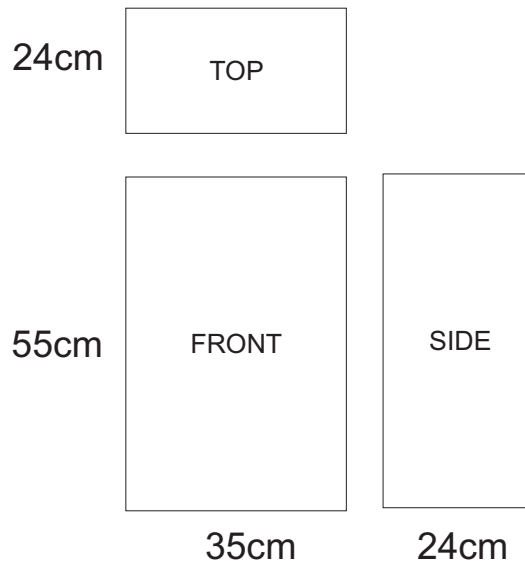

initially size in consideration is taken as 55cms thats cabin size luggage

similar design will be adopted for the range of other luggage

material combination

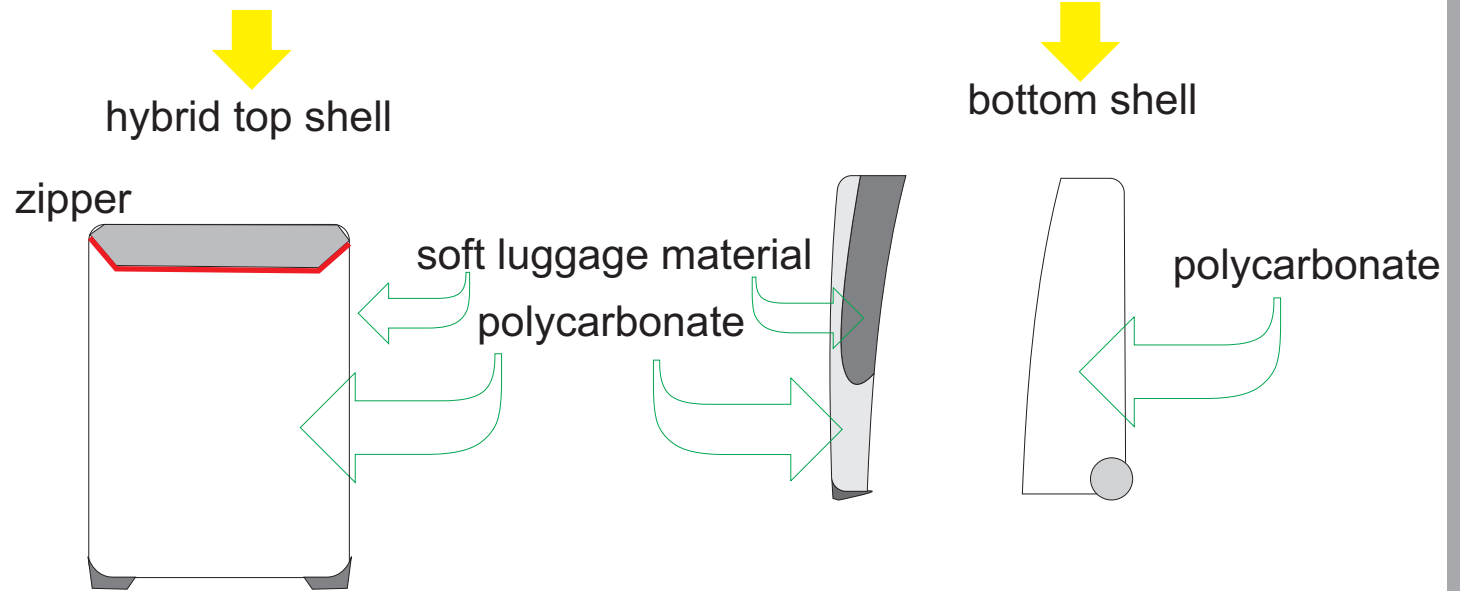

colour & texture

colour colours will be decided once the final design is complete
 bottom shell will have darker shade as compared top shell

colour combination for the hybrid front shell will be decided
 once the styling is freezed

texture polycarbonate surface will be glossy mirror finish for the top shell
 and can be relatively matte for the bottom shell

multi-textured finish is possible with dual mold
 impression vacuum forming

locking & closing / opening

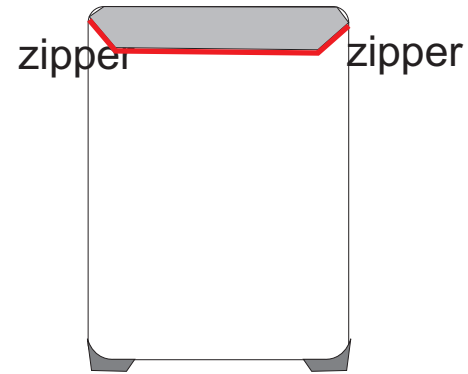

zipper closing will be such that minimizes the thickness of the bidding & closing detail
pullers for the zippers will have styling blending with the bag styling

TSA lock for bigger size bag

TSA lock will be redesigned for better interaction and functional aspect
optional locking for cabin size bag

hybrid variation

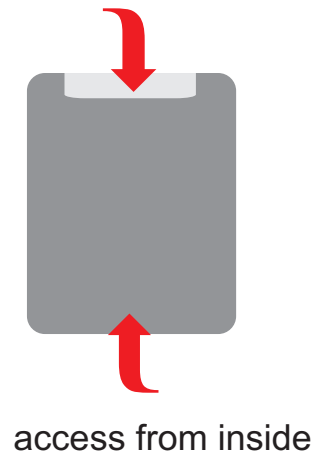

trolley

trolley projecting out of the surface yet fitted from inside

trolley integrated with top handle

v- frame trolley

collapsible trolley

wheels

hubless wheels

ball and socket wheels

wheels integrated with lugs

lugs

single lug at the centre

loop lug

three lugs

lug integrated with wheel

handle

top handle integrated with trolley handle

loop handle

retractable handle with different mechanism

pullers

reverse trouser pullers

magnetic puller

loop pullers

interior

expander compensator take away bag

LED light inside bag

Layered packaging aid

compartment

concepts VARIATIONS

3 concept designs are generated, such that each concept will have different concept hardware and style. Adopting idea derived in idea clusters of each component are judiciously merged together to come up with three primary concepts. These concepts are evaluated to get the best possible out of them.



1



2



3

CONCEPT 1



EVERLIFE

The logo features the word "EVERLIFE" in a bold, italicized, sans-serif font. The letters are white with a thin black outline. To the left of the word, there are two rows of colored dots: a top row of five blue dots and a bottom row of five purple dots. Above the letter 'I', there is a vertical stack of four colored dots: green, blue, light blue, and purple.



1

A large, white, italicized number '1' with a thin black outline, positioned to the right of the "EVERLIFE" text. It has a slight shadow effect.

CONCEPT 1

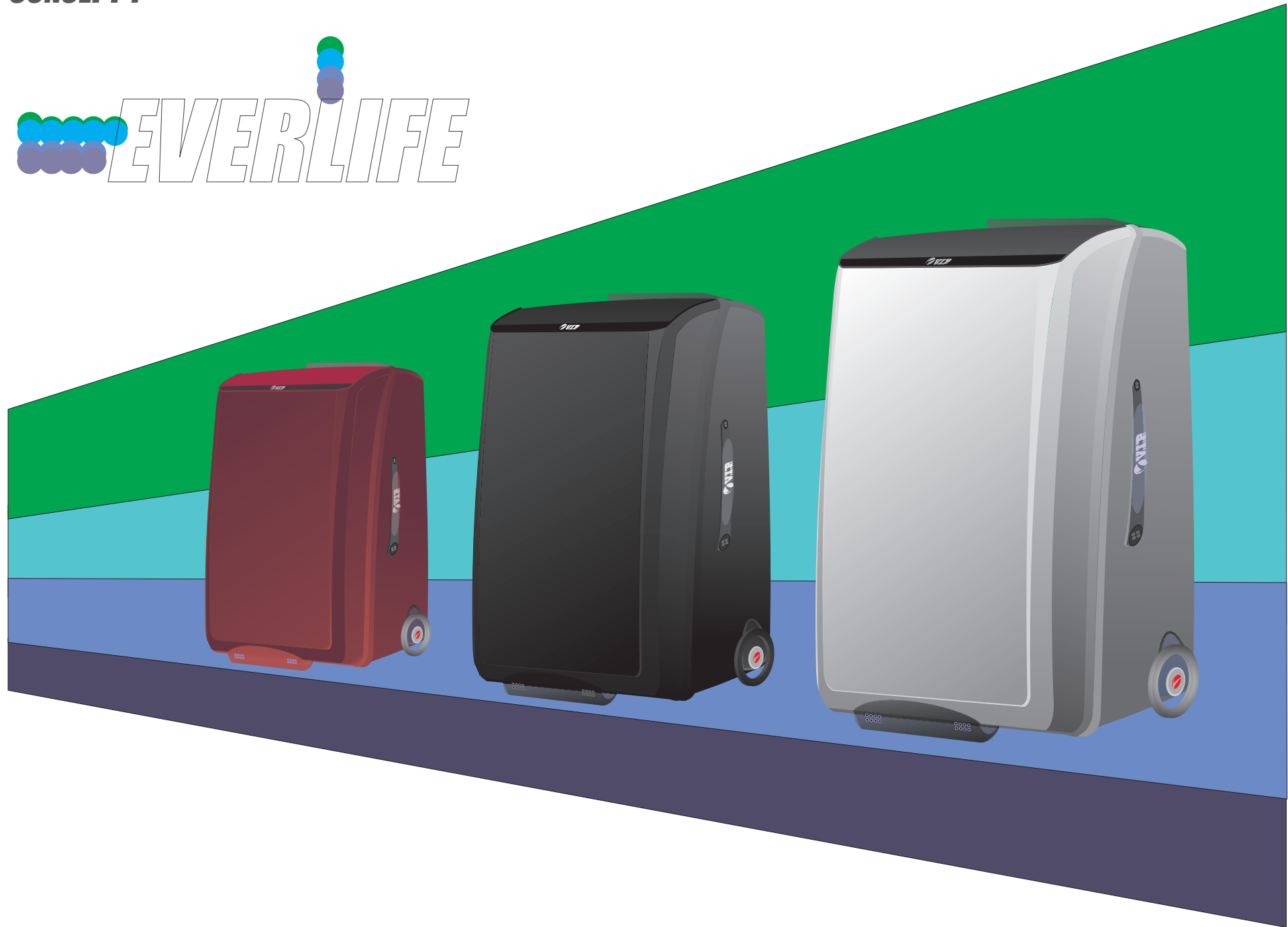

CONCEPT 1



CONCEPT 1

 **EVERLIFE**

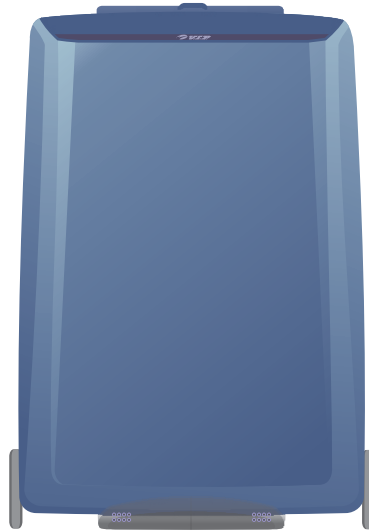

CONCEPT 1

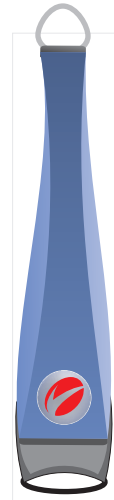
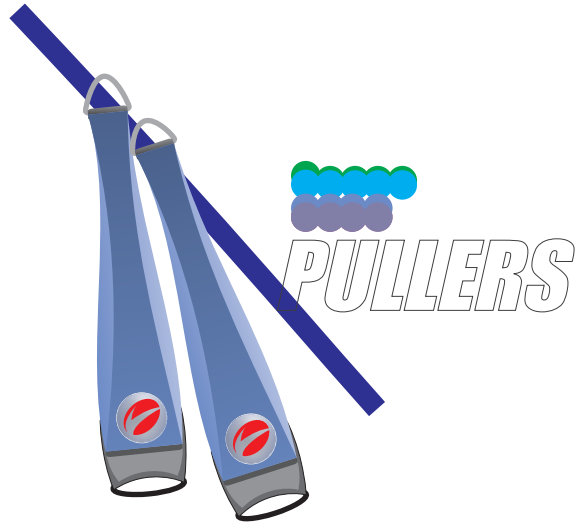

50MM

15MM

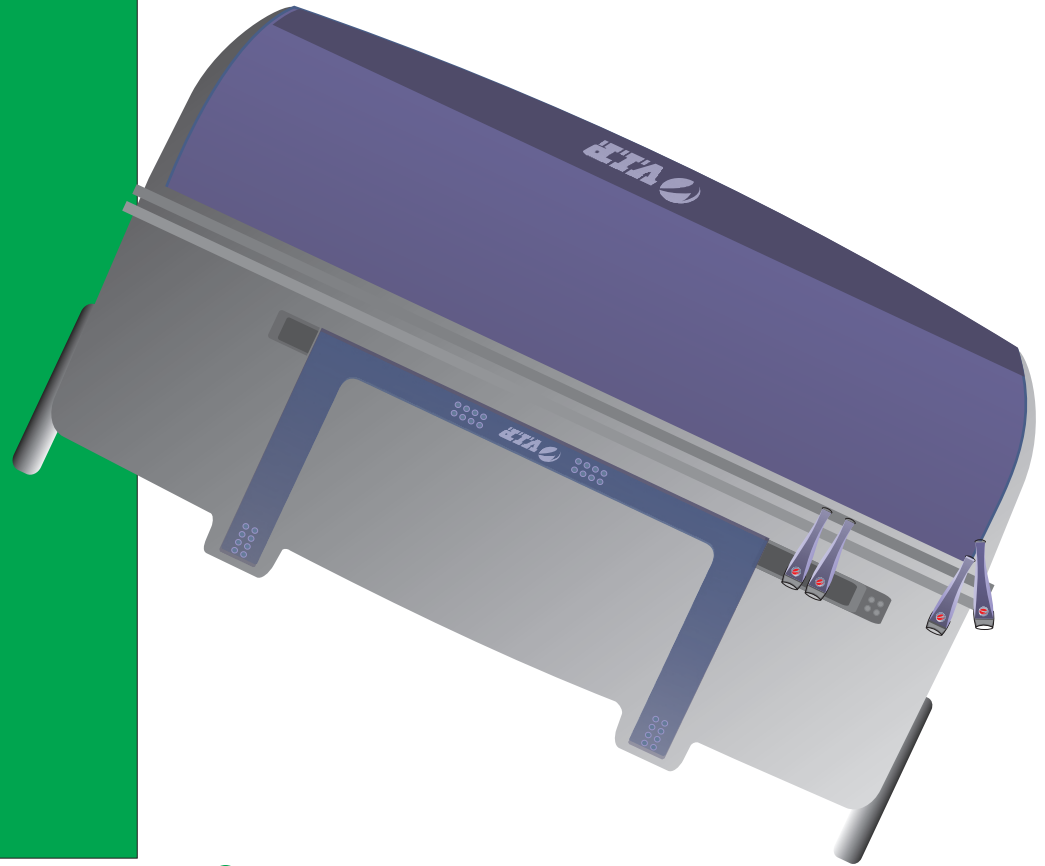

CONCEPT 1

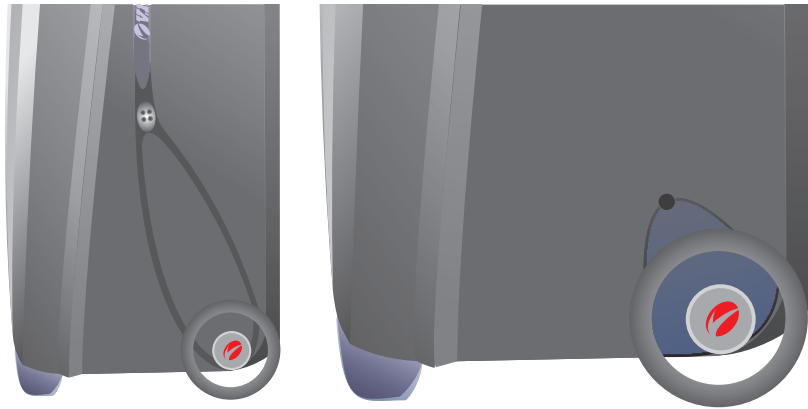

WHEELS

HUB LESS WHEELS FITTED ON THE SIDE THAT HAS BRANDING AT THE CENTER AND IS ATTACHED TO BAG WITH RIVETS OR ULTRASONIC WELDING

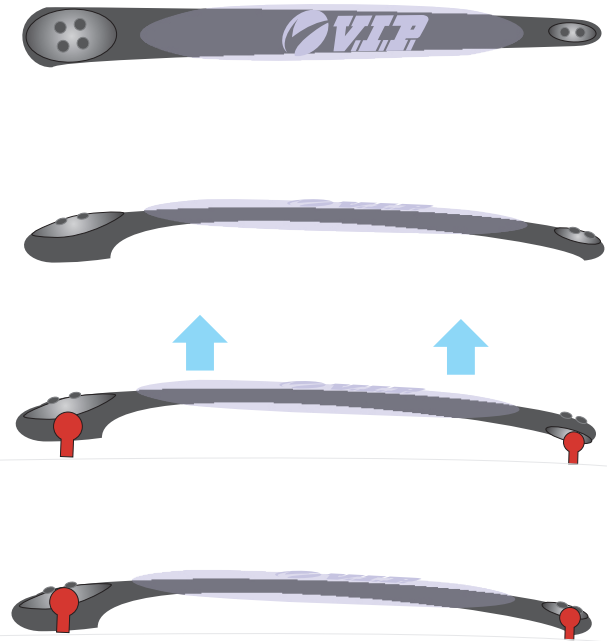
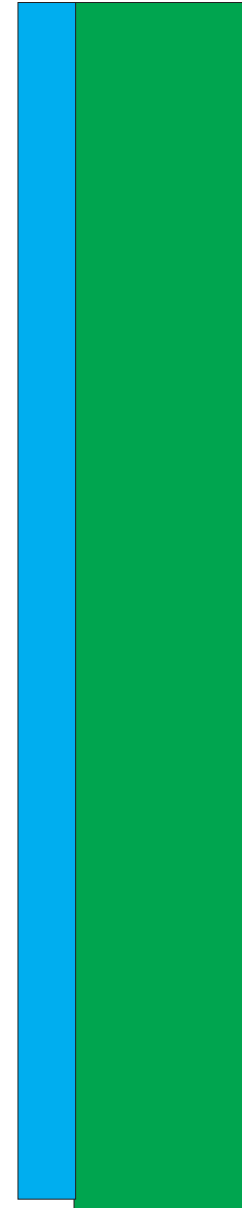
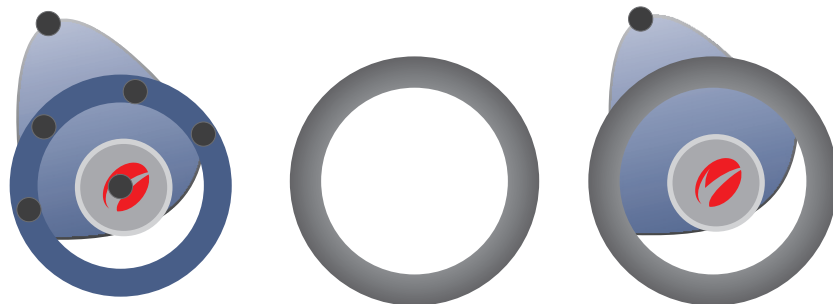

SIDE HANDLE

SIDE HANDLE IS SYMMETRICALLY FITTED ON BOTH SIDES OF THE BAG, HENCE WHEN RIGHT SIDE HANDLE IS USED LEFT ONE SERVES AS GROUND REST AND VICE VERSA

CONCEPT 1



BOTTOM LUG

BOTTOM LUG IS FITTED AT THE CENTER AND HAS A CAVITY BENEATH THAT MAKES IT AS A LIFT HANDLE AND ALSO REDUCES WEIGHT & MATERIAL COST.



FRONT SHELL OPENS AT APPROXIMATELY 110 DEGREES AND STAYS THERE WITH THE LUGS RESTING ON BOTTOM SHELL SURFACE



CONCEPT 1

 *TROLLEY* +  *HANDLE*



CONCEPT 1

USUALLY STUFF INSIDE LUGGAGE IS ALWAYS MORE WHILE JOURNEY BACK HOME BECAUSE OF SHOPPING ETC. HENCE NORMALLY EXPANDER HELPS YOU OUT WITH THAT. HERE THE MESSENGER BAG SERVES AS EXPANDER COMPENSATOR AND PROVIDES EVEN MORE SPACE FOR EXTRA STUFF.

EXPANDER COMPENSATOR

COLLAPSIBLE MESSENGER BAG IS PLACES AT THE PLACE BETWEEN TROLLEY STEMS THIS BAG WILL BE IN USE WHILE LOCAL ROAM AROUND ONCE YOU REACH THE PLACE

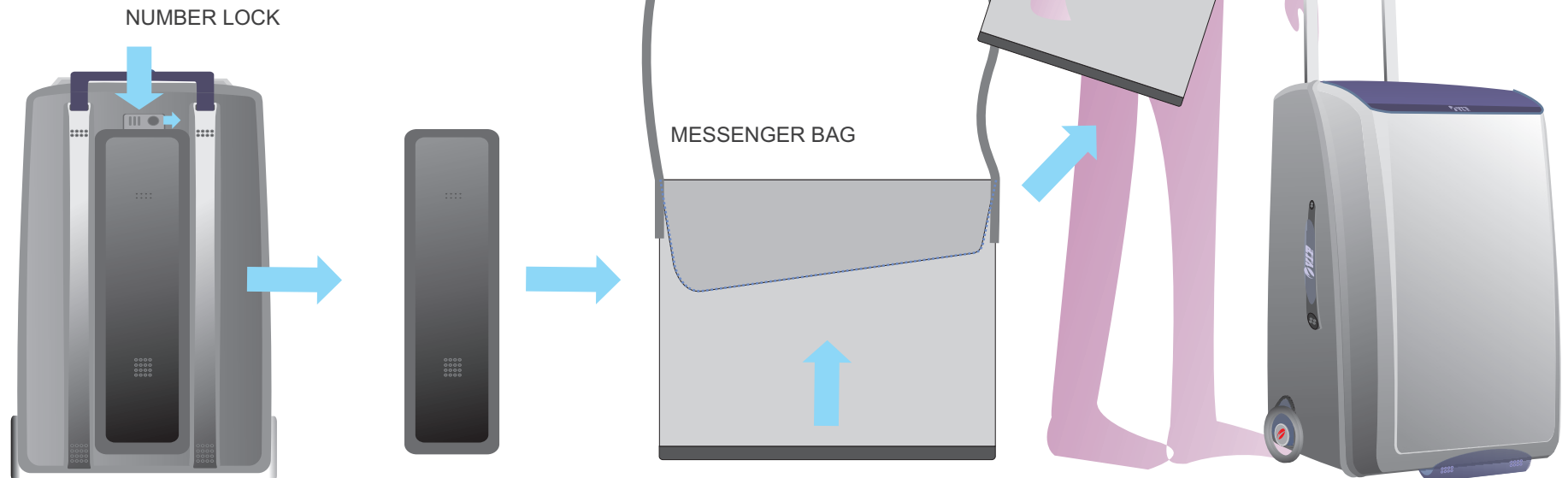

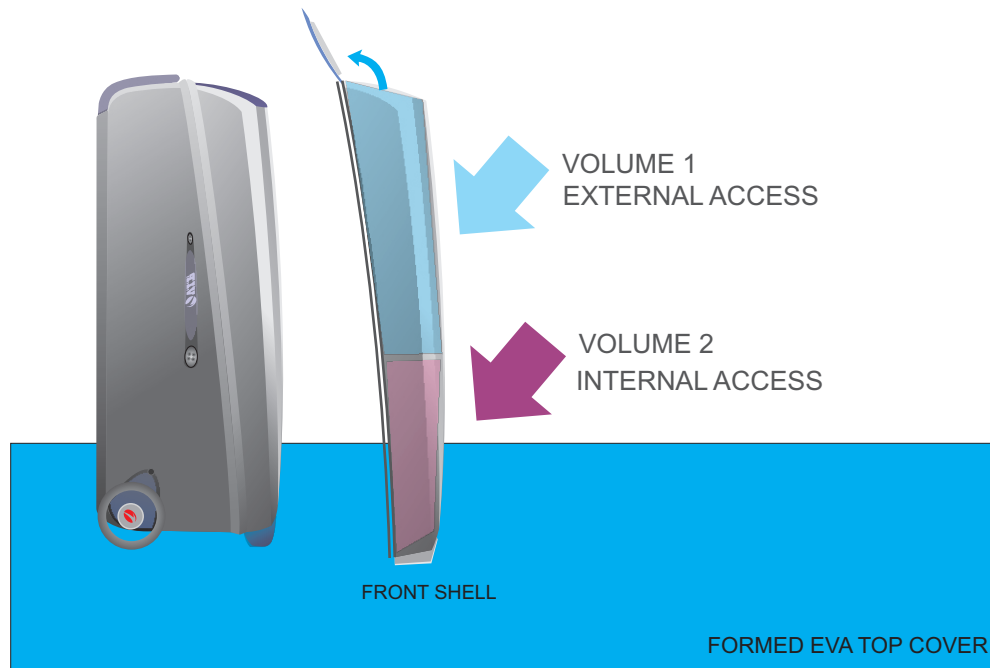

USUALLY THE THINGS WE NEED DURING THE TRAVEL ARE KEPT IN OUTER EXTERNALLY ACCESSIBLE POCKET IN THE FRONT SHELL. SO THAT USER DON'T NEED TO OPEN UP WHOLE BAG TO ACCESS THE THINGS HE NEEDS DURING THE JOURNEY. AT THE SAME TIME THIS KEEPS DIRTY FOOTWEAR OR WET TOILETRY POUCH AWAY FROM NEAT & IRONED CLOTHES

SHOE POUCH



TOILRTRY POUCH



EYE-WEAR ETC



INTERIORS



CONCEPT 1

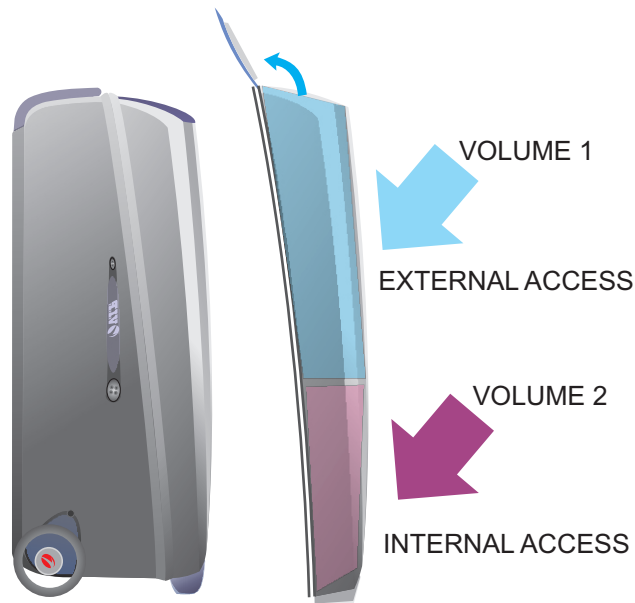

FRONT SHELL

FRONT SHELL OPENS AT APPROXIMATELY 110 DEGREES AND STAYS THERE WITH THE LUGS RESTING ON BOTTOM SHELL SURFACE

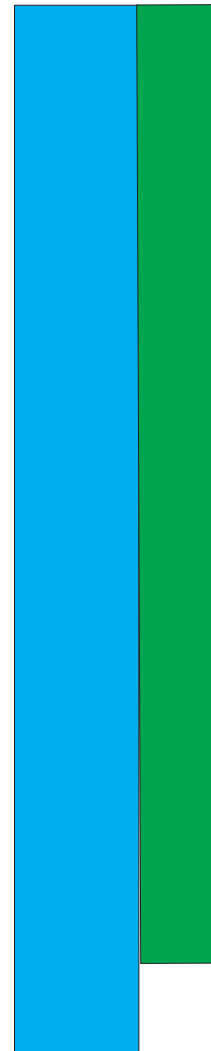
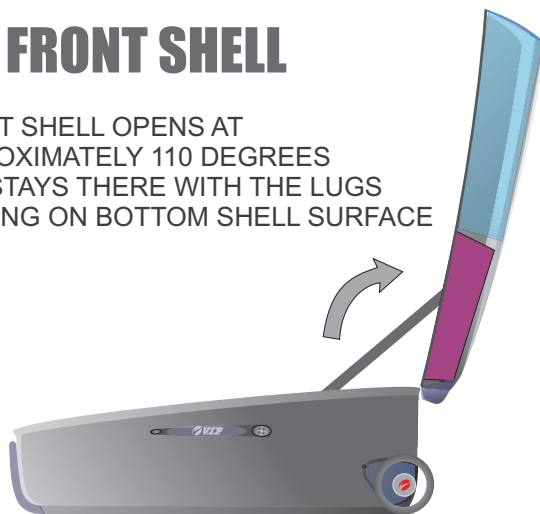

DETAIL SIMILAR TO SLING BAG

USED CLOTHES, JUNK WEAR, NIGHT WEAR ETC

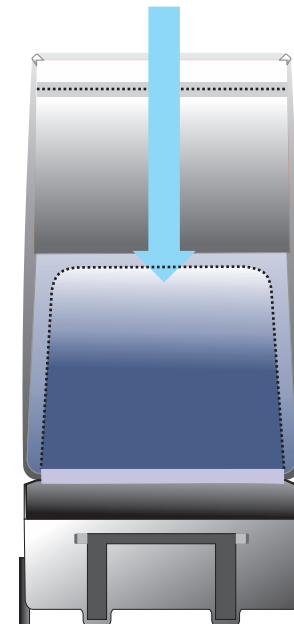

TRANSPARENT POCKET WITH ZIPPER

PAPERS, DOCUMENTS BOOKS ETC

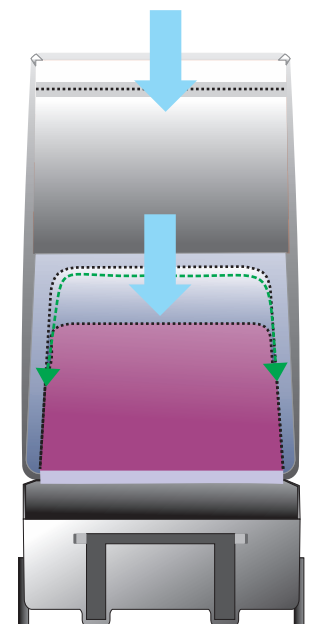

HINGE

CONCEPT 1



BOTTOM SHELL

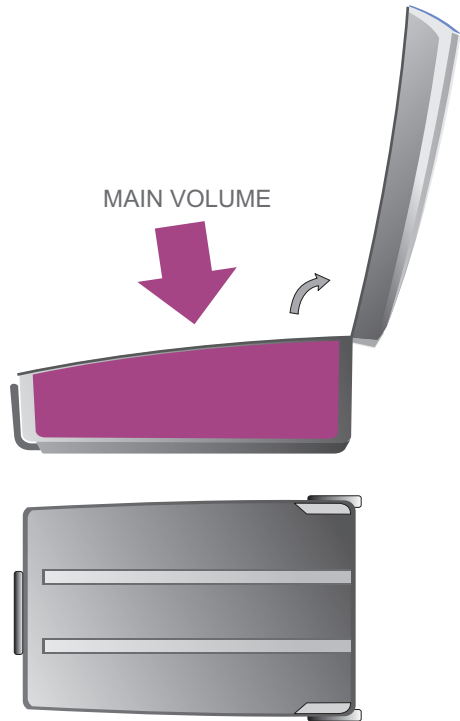

TOP VIEW

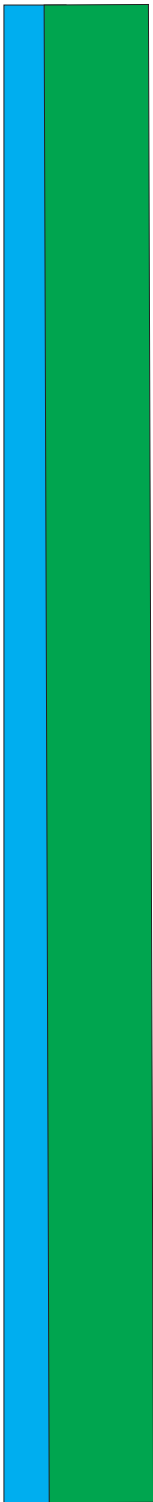

THIN PVC MAT STUCK ON THE BOTTOM THAT COVER UP THE TROLLEY STEMS AND INSIDE SURFACE IS SMOOTH, LEVELED AND NEAT.

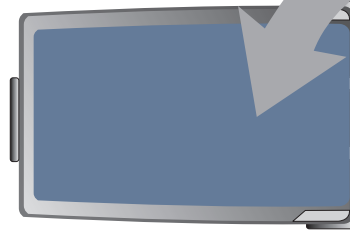

DIVIDER THAT IS FITTED WITH THE (LPA) LAYERED PACKING AID COMPONENT. THIS HELPS IN PACKING THE LUGGAGE WHERE ONE CAN LAYER APART HIS FORMAL IRONED CLOTHES.

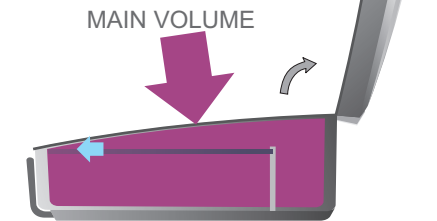
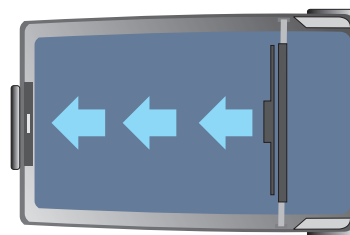

TOP VIEW

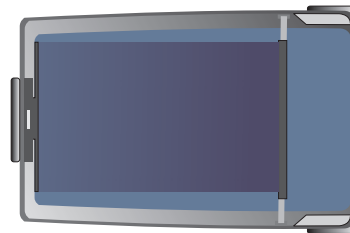

INTERNAL LIGHTING AID WITH PANEL FITTED WITH 4 LED'S AND A BUTTON BATTERY THAT THROWS ENOUGH BRIGHT LIGHT TO LOCATE THE THINGS INSIDE AT NIGHT THIS IS FITTED ON THE EXACT BACK SIDE OF THE LOCK FITTING AND ALSO HOOKS IN THE LPA

CONCEPT 2

OLE!

ORIGINAL LIMITED EDITION 

2

CONCEPT 2

OLE!

ORIGINAL LIMITED EDITION **VIP**



CONCEPT 2

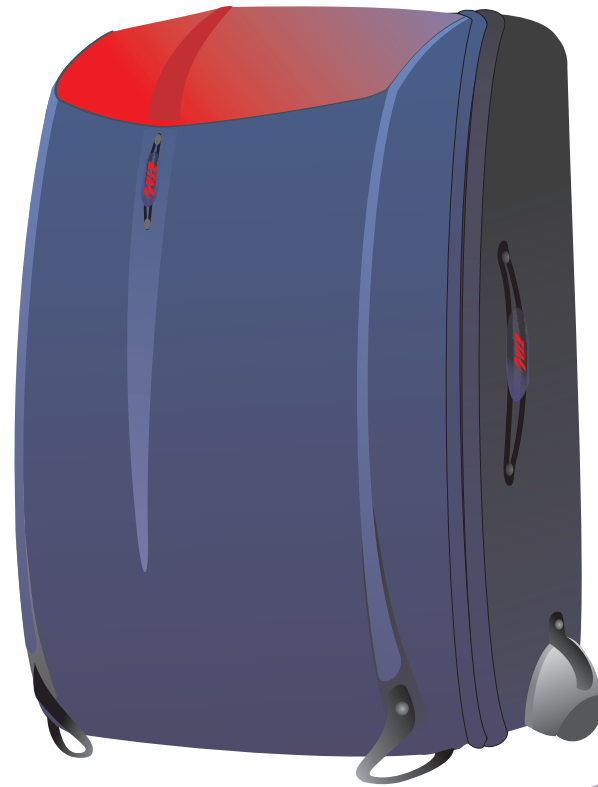

OLE!

ORIGINAL LIMITED EDITION 



CONCEPT 2



CONCEPT 2

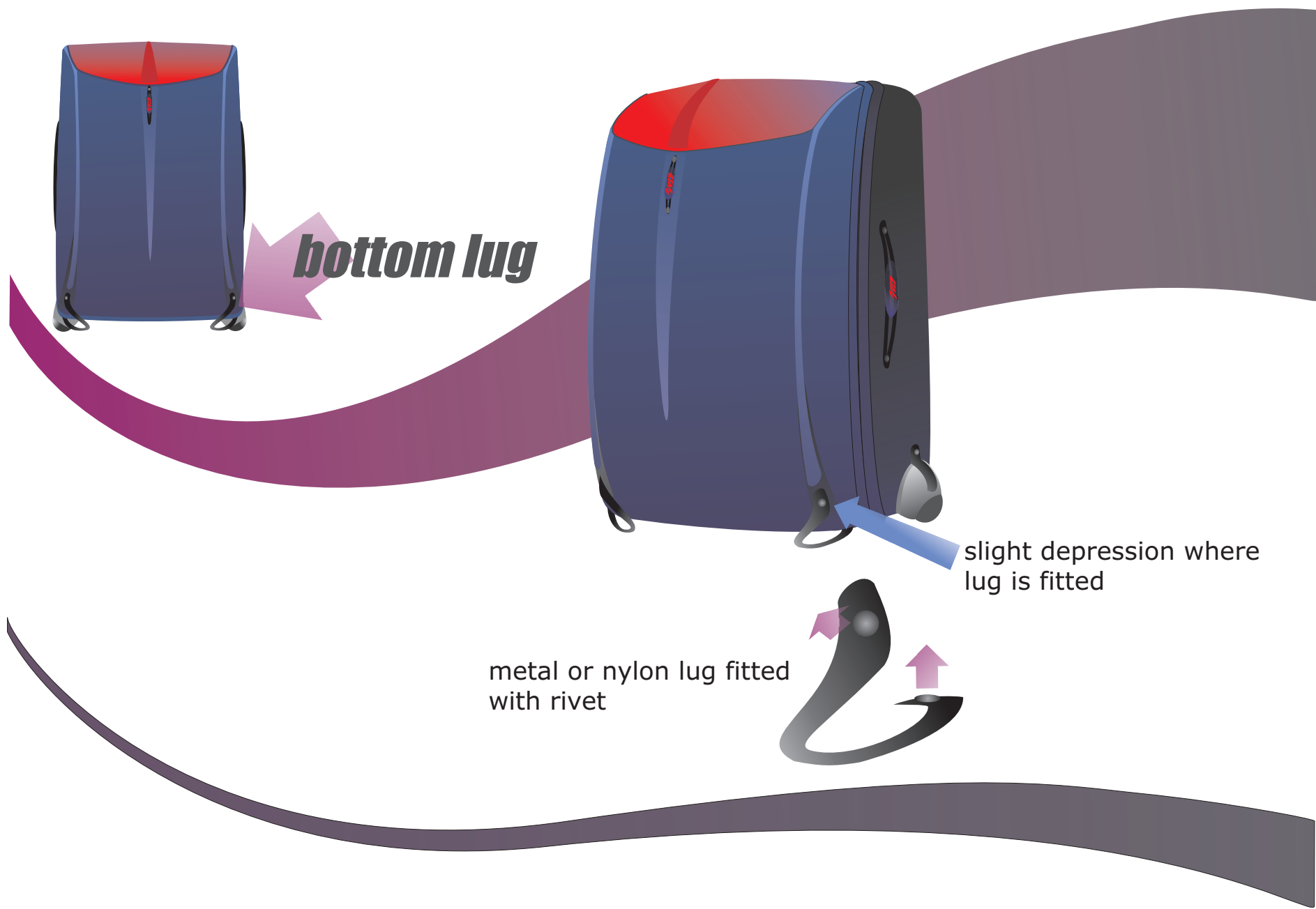

CONCEPT 2



wheels



ball and socket 360 degree wheel

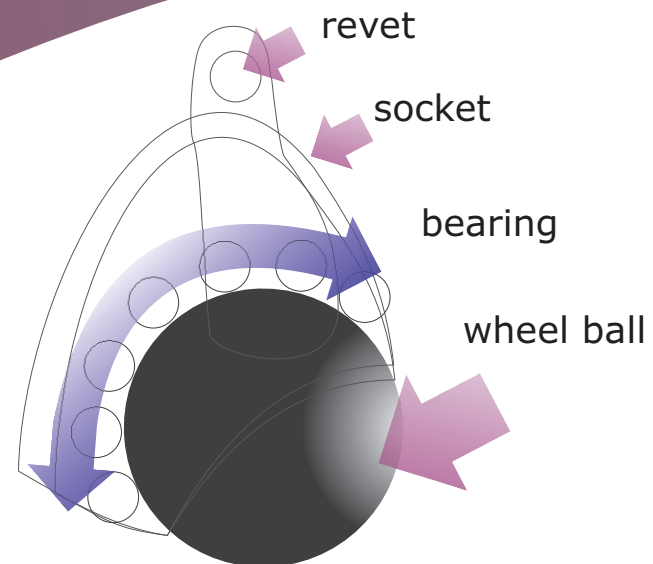

CONCEPT 2

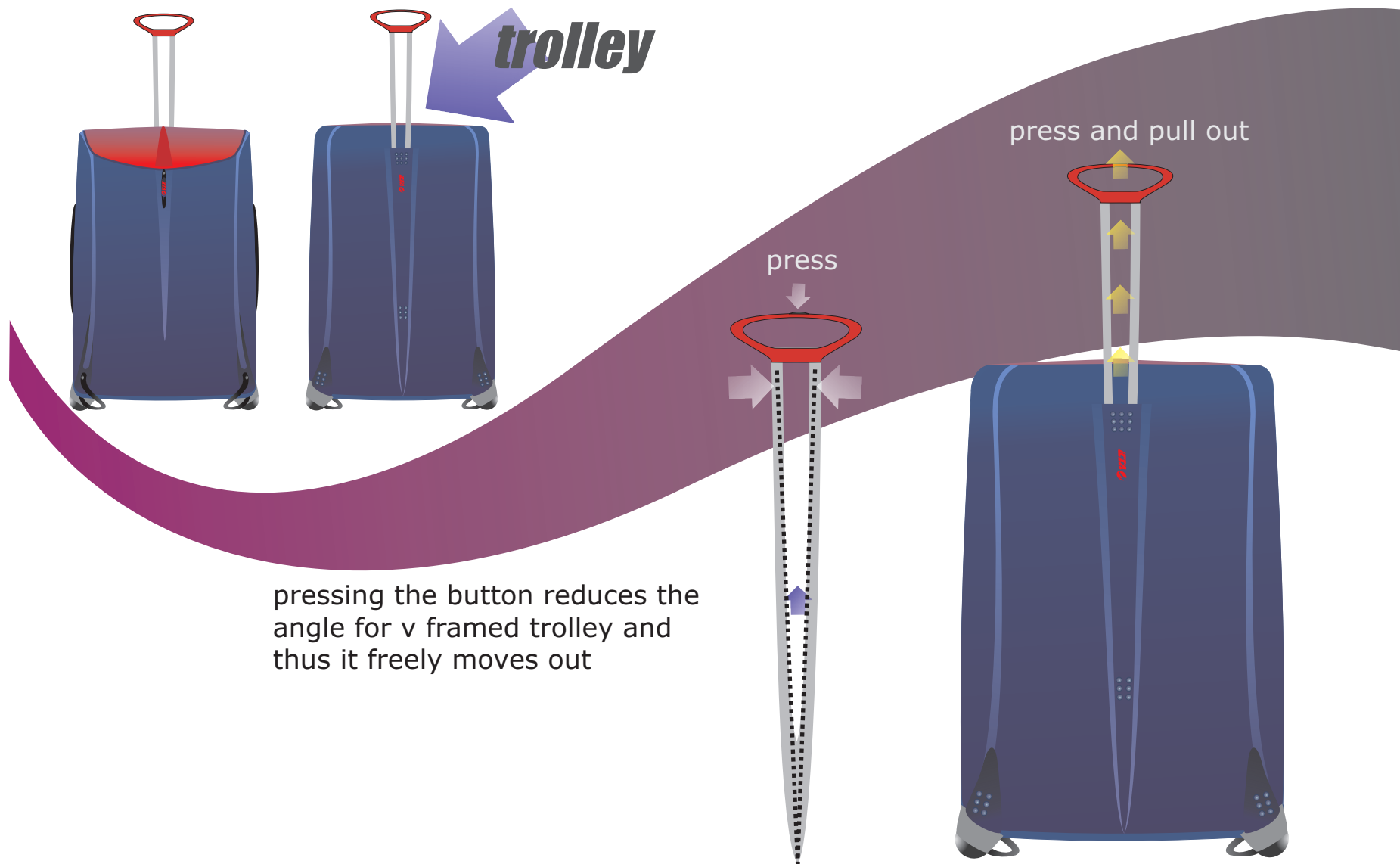

CONCEPT 2

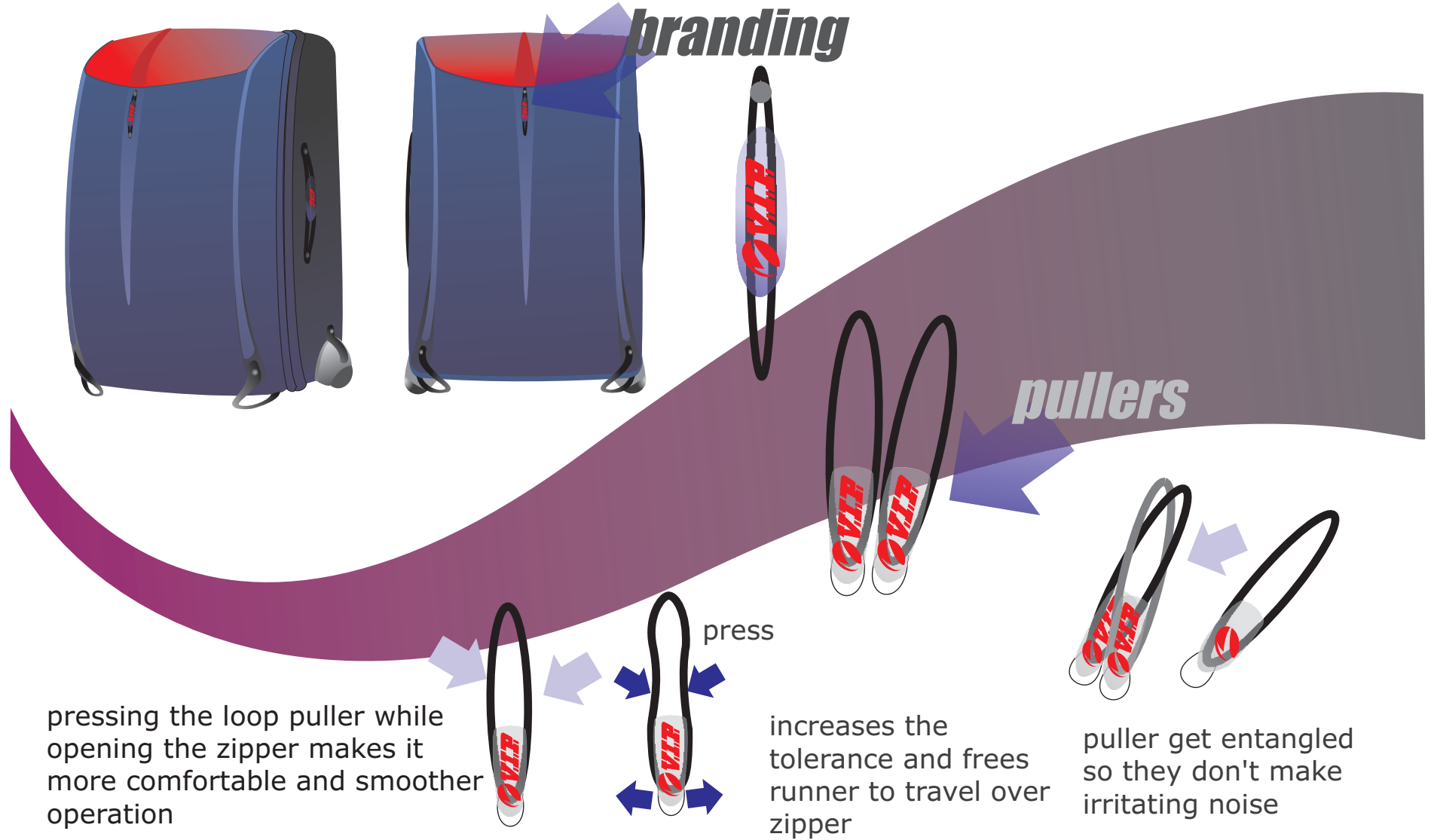

CONCEPT 2

interiors

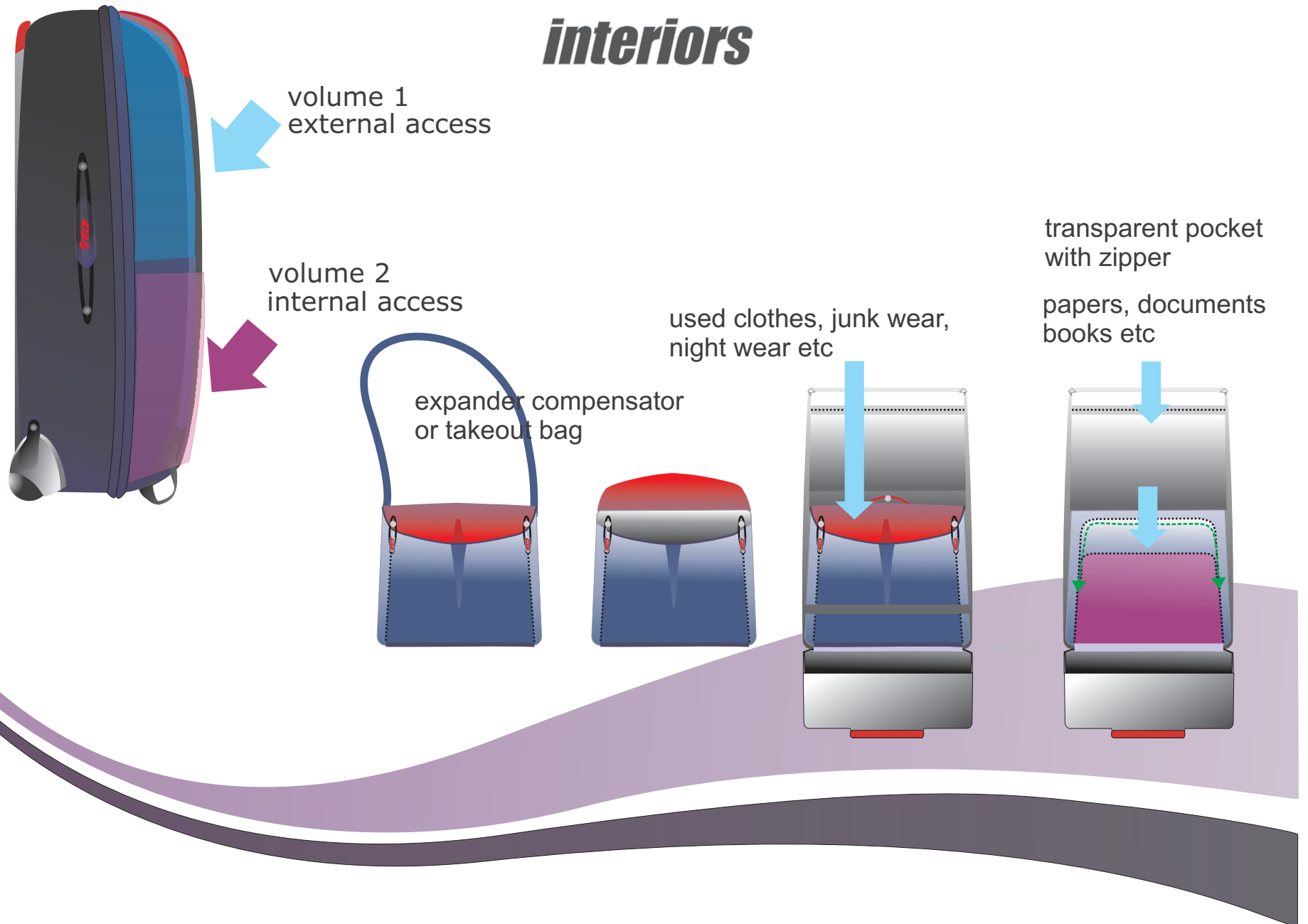

CONCEPT 3

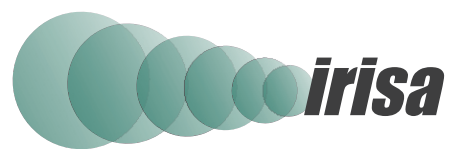

3

CONCEPT 3



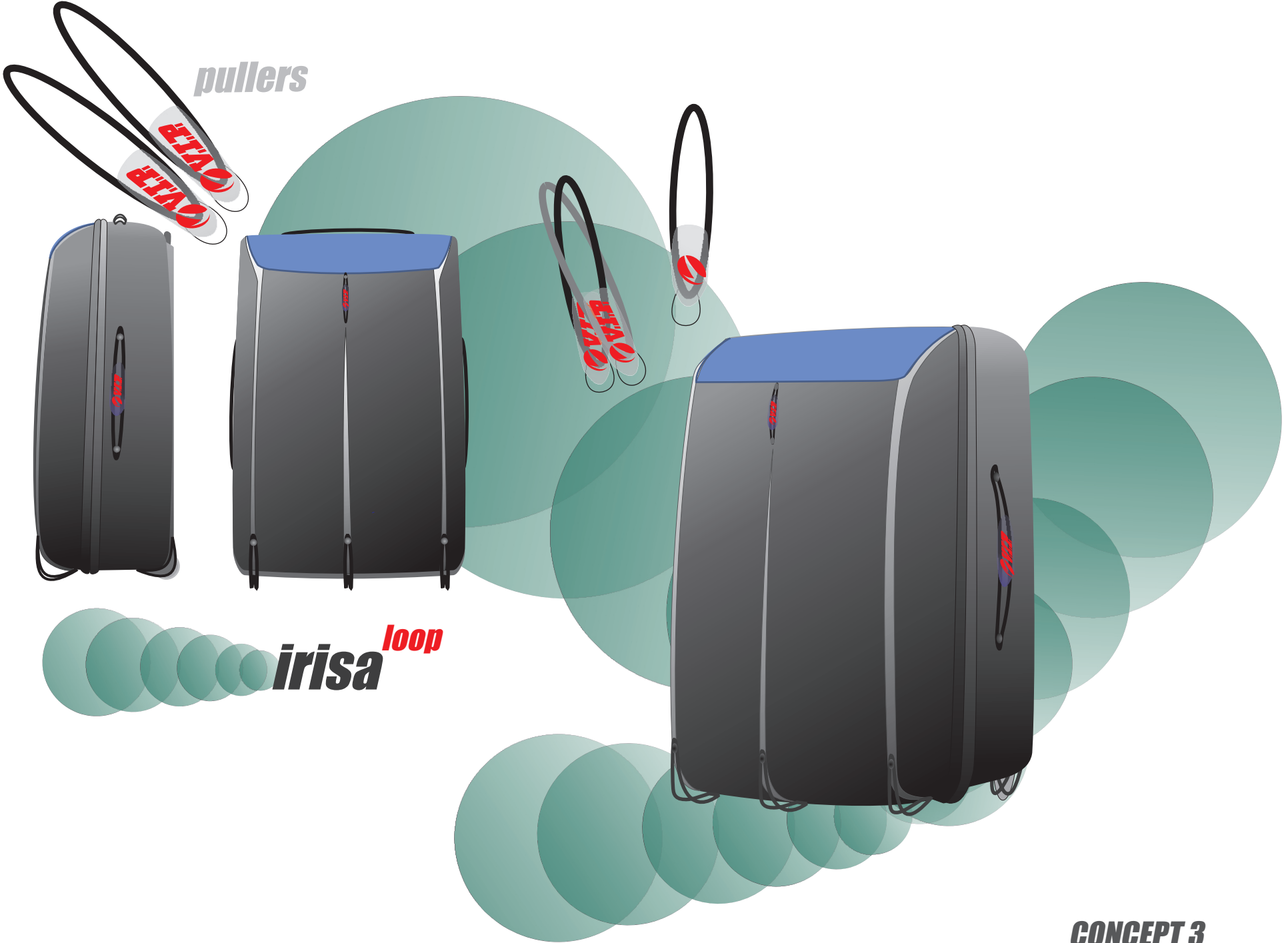

pullers

BLAD

BLAD

irisa *loop*

CONCEPT 3

CONCEPT 3

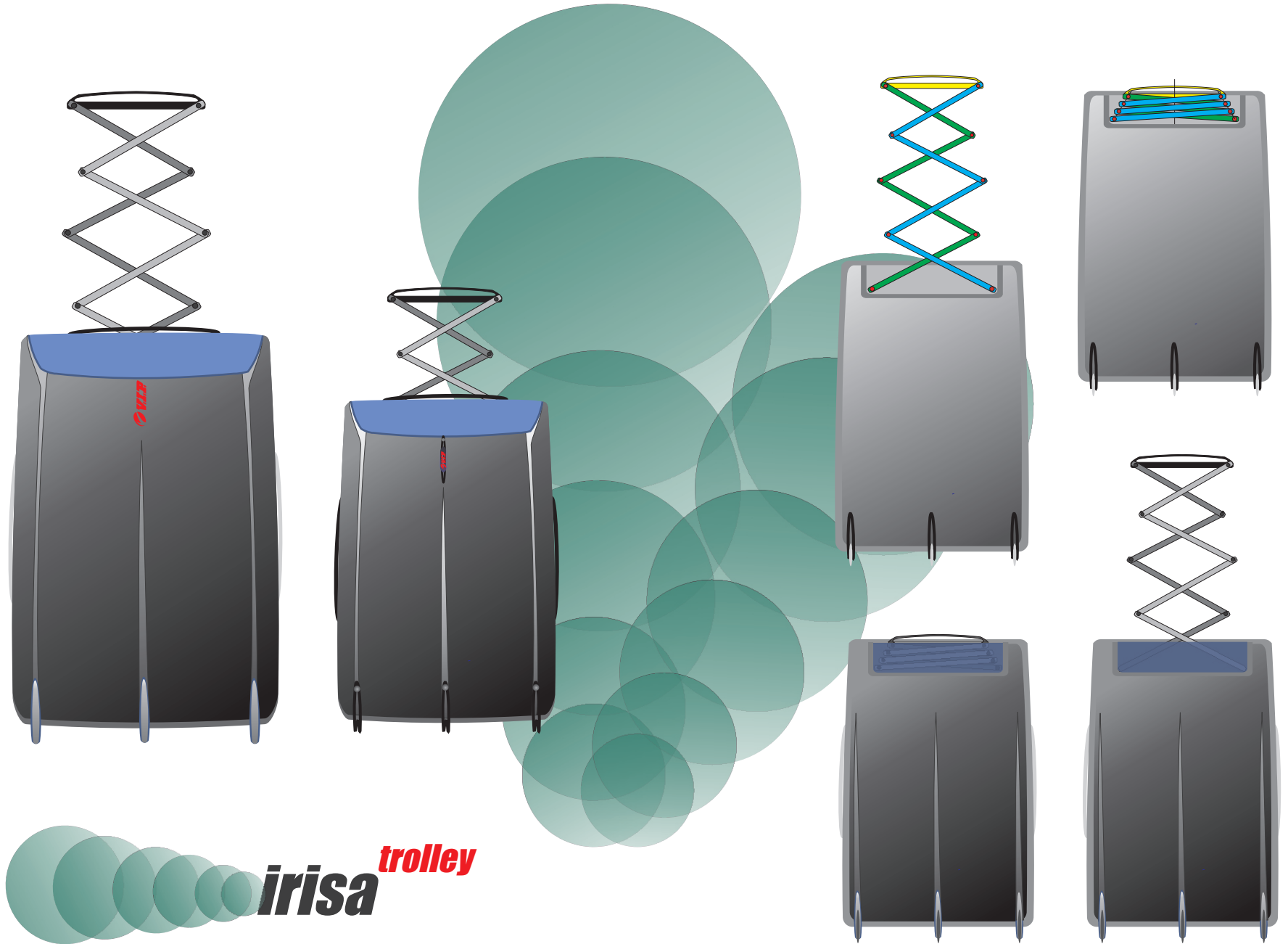

CONCEPT 3

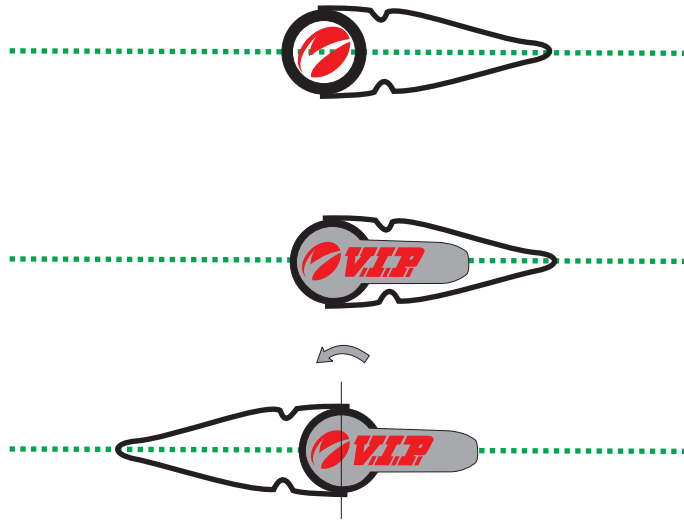

trouser pullers that has flip-up and lock feature

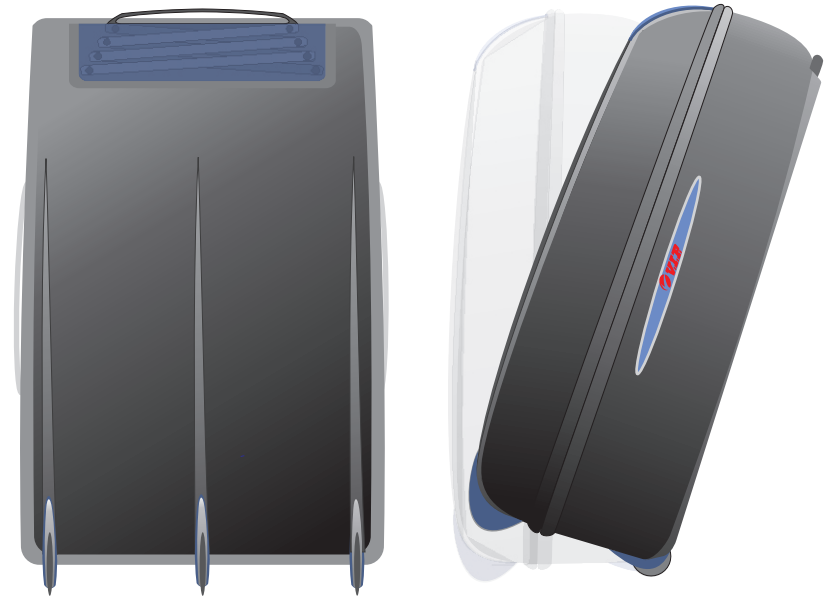

CONCEPT 3

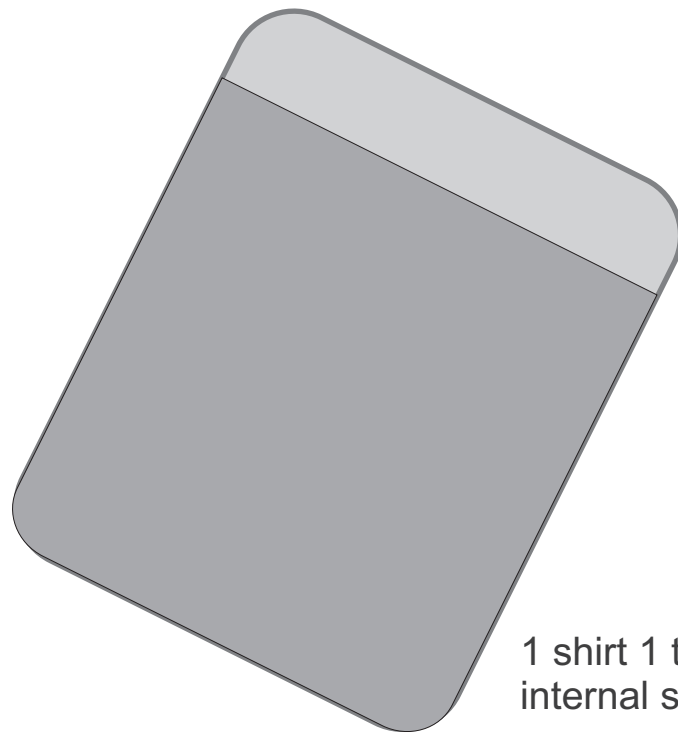

1 shirt 1 trousers and a tie fits in this internal separator

CONCEPT evaluation

CONCEPT 1



CONCEPT 2



CONCEPT 3



	CONCEPT 1	CONCEPT 2	CONCEPT 3
overall styling	● ● ● ○ ○	● ● ● ● ○	● ● ● ● ○
trolley concept	● ● ● ○ ○	● ● ● ● ●	● ● ○ ○ ○
wheel concept	● ● ● ○ ○	● ● ● ● ○	● ● ● ● ●
lug concept	● ● ○ ○ ○	● ● ● ● ○	● ● ● ● ●
interior concept	● ● ● ● ○	● ● ● ○ ○	● ● ● ○ ○
puller concept	● ● ● ● ●	● ● ● ● ○	● ● ● ● ○
branding concept	● ● ● ● ○	● ● ● ○ ○	● ● ● ● ○

none of the concept is entirely dominating so final concept is amalgamation of the best features from each concept.

final concept

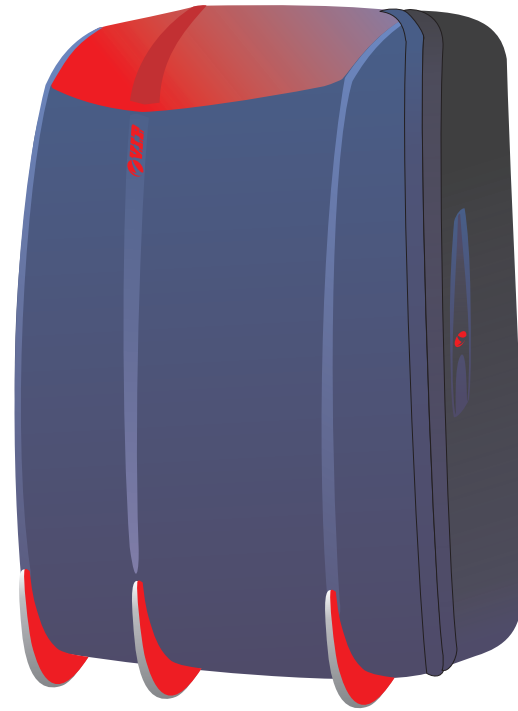
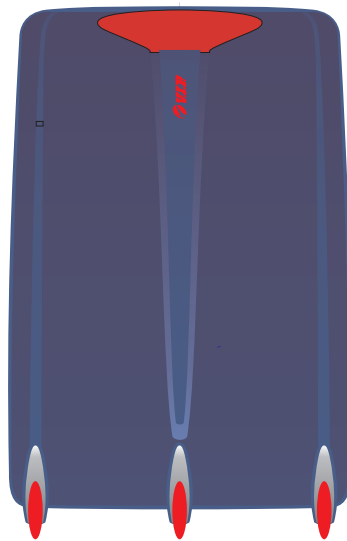
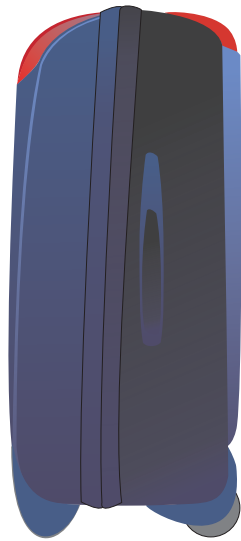
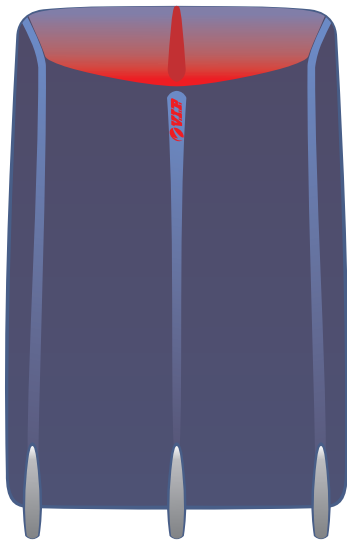
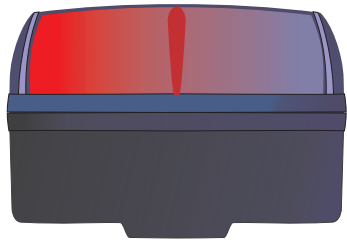

Drawing

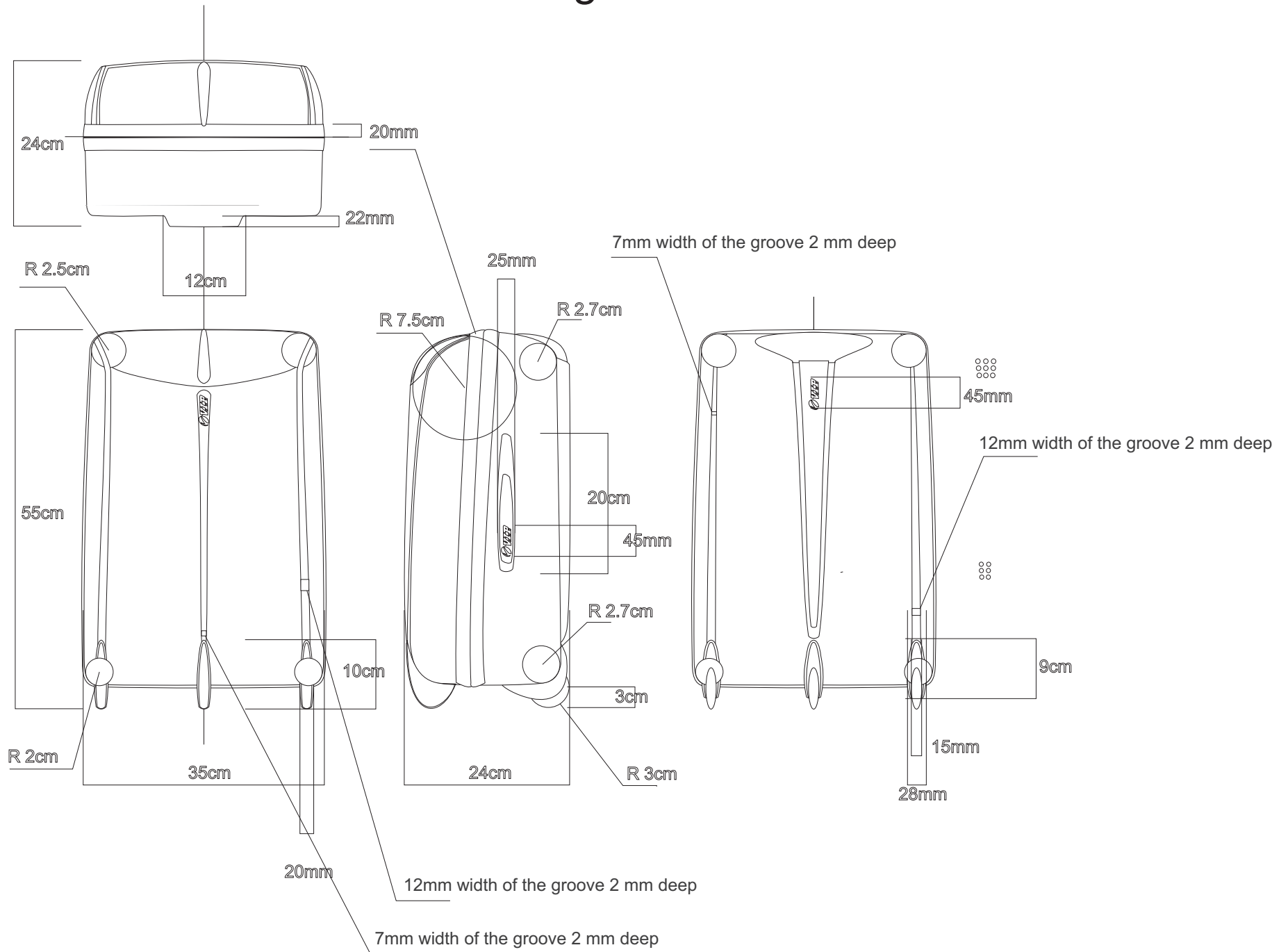



ATUL PARANIPE 05613802
LUGGAGE DESIGN 



journey in progress