

# INCONSPICUOUS FURNITURE

Kiran Kumaran  
02613010

Guide Prof. Suresh Sethi





Metal rail that curves inland, making one realize the wind. as if coaxing the walker to stop and lean on it.

*Esplanade, view south toward South Cove, Battery Park City, New York City, by Hanna/Olin and Cooper Eckstut, 1979*



Intermediate posture.

Inconspicuous





The most commonly observed intermediate postures and short time span seating are seen outdoor.

Streets, bus stops, places of waiting , hang out areas like shopping malls , beaches facing sea, outdoor food joints.



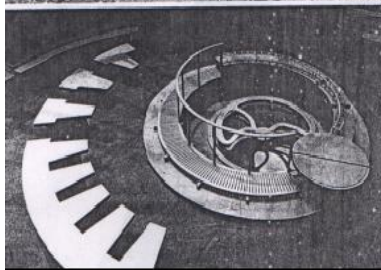
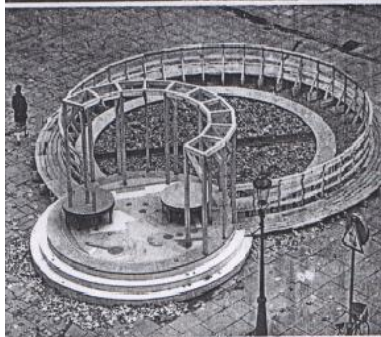
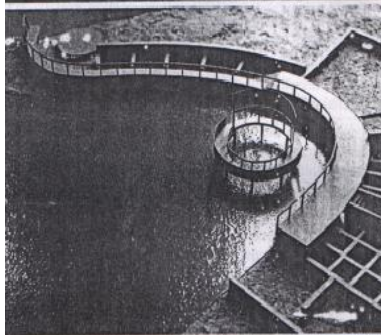
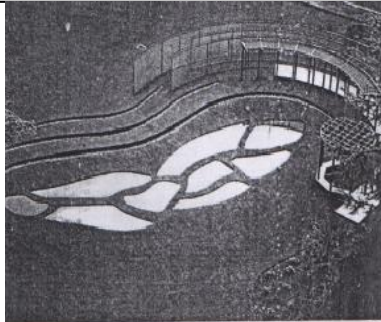

**Public Art**

**Confronting presence**

**Furniture as public art**

**Furniture to engage.**

- Miss Mary - Collection of works(1966-1987)



*Everyday, the sidewalks that I walk, the corridors that I pass through. They have become so mundane that I don't see around me.*



### **Experience.**

visual  
physical.

The aesthetics of objects.  
The aesthetics is of experience.



## **Play or Activity**

Making the user a participant. A part of the whole experience to create engagement.



*Jantar Mantar*

## **Group of objects**

A series of objects. The experience of the user when he moves in that space, confronting one object after the other, using contrast or continuity to engage.



*The Temple of Athena Parthenos, the Parthenon*

## **Time**

Aesthetics that recognizes the flow of passing time as well as the singularity of the moment in time.

## **Engagement in Ruins.**

Imaginative reconstruction.  
Aesthetics of historical or social content.  
Keeps ruining.



## The Scale

Aesthetics of experience in space. That celebrates motion or movement of body.

Unification of the object and the space.  
motion - change

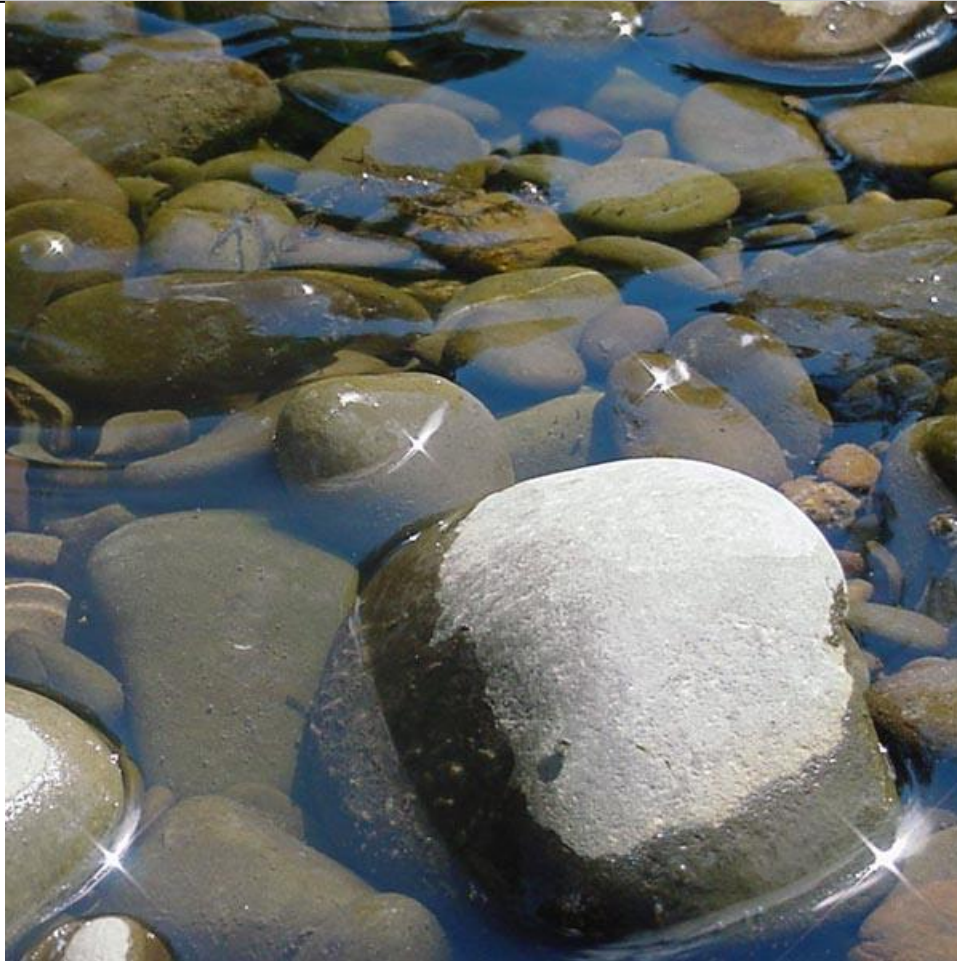

## **Nature**

Dynamics of change .  
Nature processes in form.  
Form as erosion.  
Form as water.  
Form as growth.

The natural phenomena like movement of the sun, seasons, the rain or wind.



## Zen Gardens

Meditation Contemplation.

Imagery or meaning is used to create the experience.



***Engagement is stopping and spending time. A pathway that says the real goal is the path itself.***



**Outdoor Seating**

Widest possible audience  
Semi resting posture.

**Grouping and interaction in public spaces.**

**Passive** (reading, people-watching, solitary contemplation etc.)

**Active** (socializing) spaces.

**Back to back seating** in curve create both active and passive spaces.

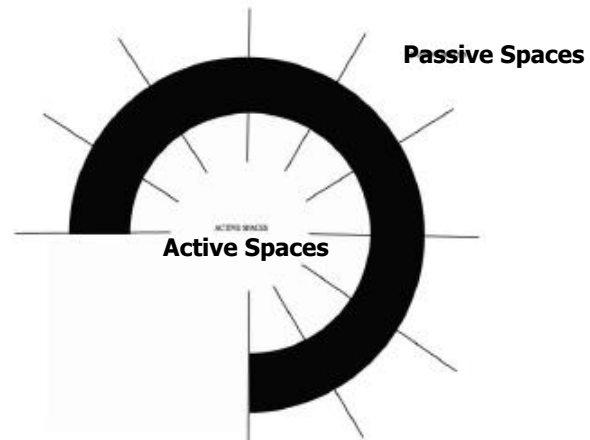

Therefore it was found that what was required was not fully ergonomic chair but objects that could be occupied by people in many different ways. So the chair necessarily need not be a chair. It could be any other object. It could be inconspicuous. It could be an object that could engage.





Outdoor furniture that could be used by human beings for Rest, Enjoying surroundings, Interaction with others.

Modular product that could be mass produced and reconfigured according to different space requirements.

To construct an **Experience to *Engage***.

Garden and Urban benches









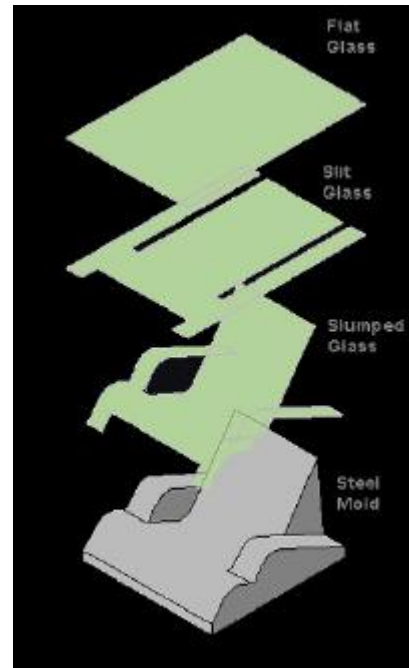



Current market is flooded with benches of various types.

Flexible shapes to suit various environments

## **market segment**

Gardens

Streets

Outdoor food joints.

short waiting ...bus stops.

beaches facing sea



### **Aims**

- To understand furniture design process.
- Materials and processes.
- Detailing.

- **The Form**

- **Manufacturing modularity**

- **Ergonomics**



# ***CONCEPTS***

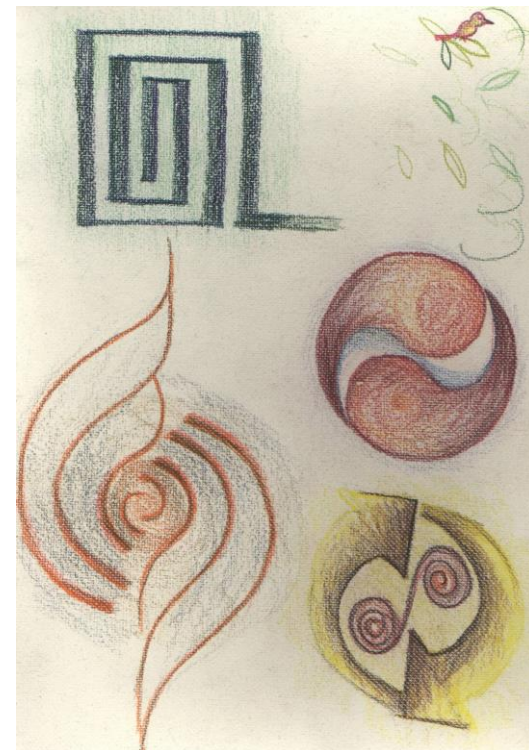
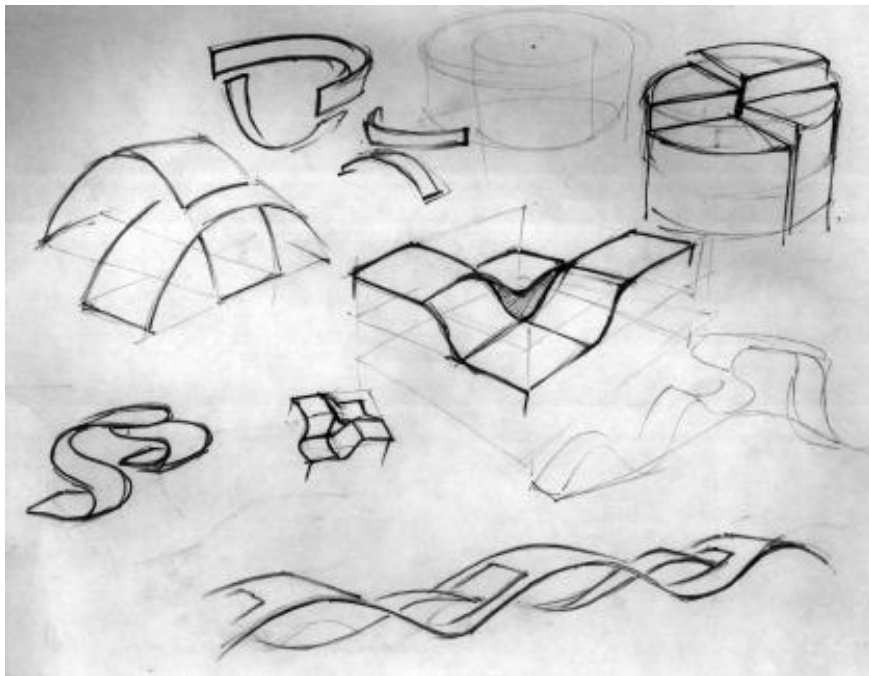
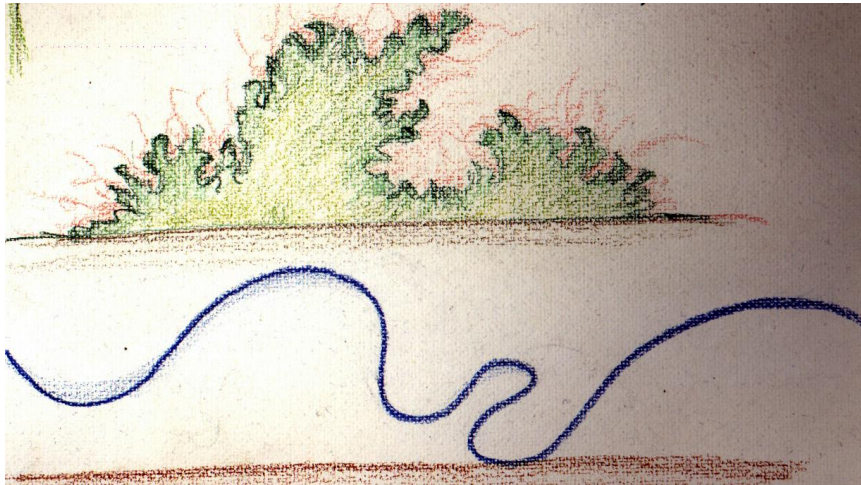

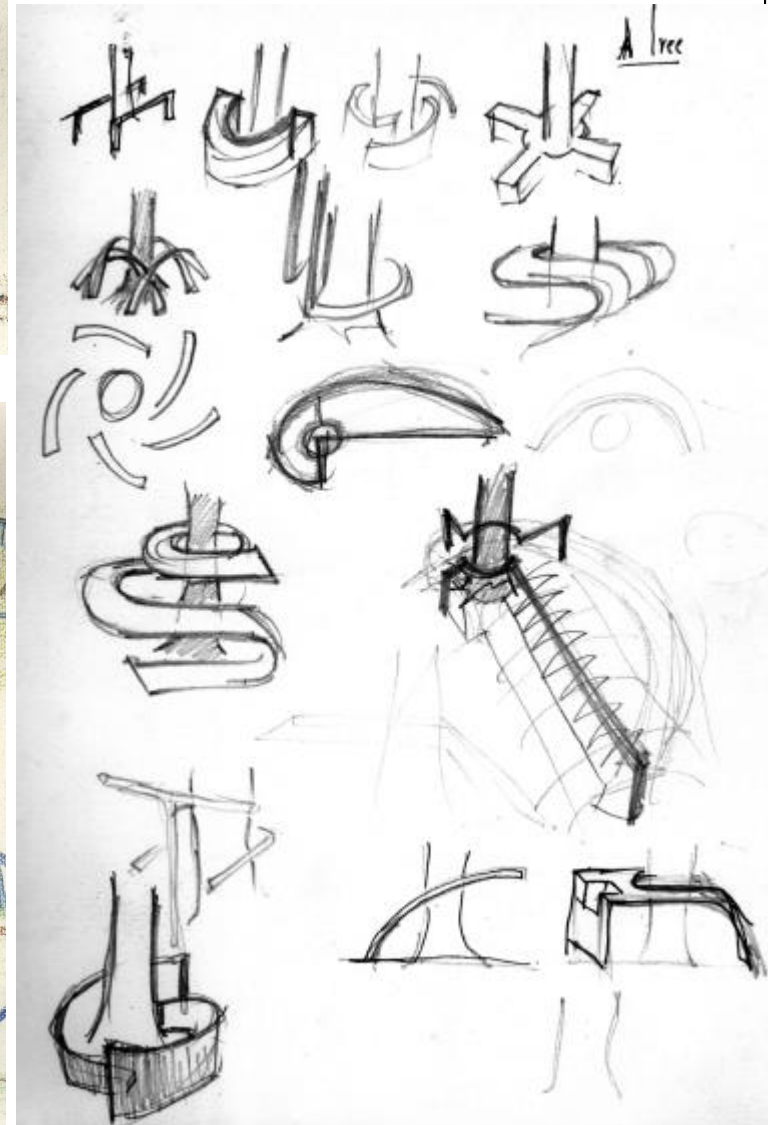
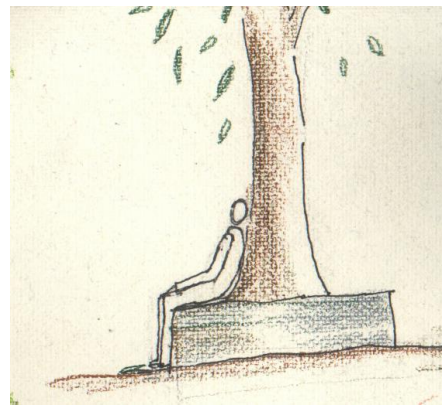

Under a tree.

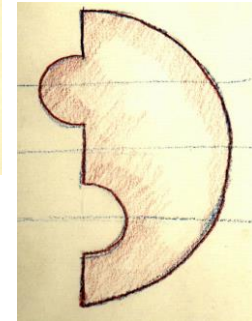
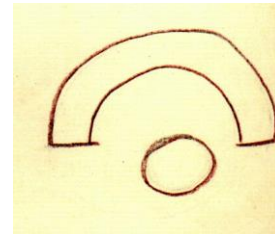
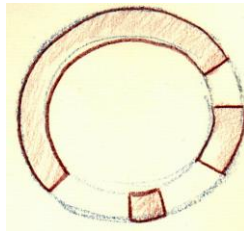
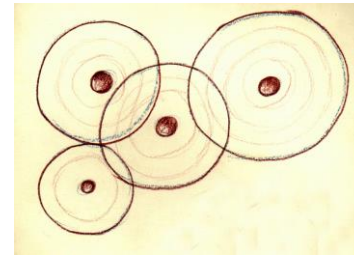
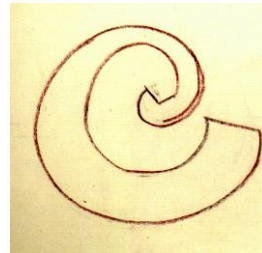
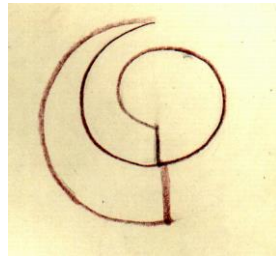
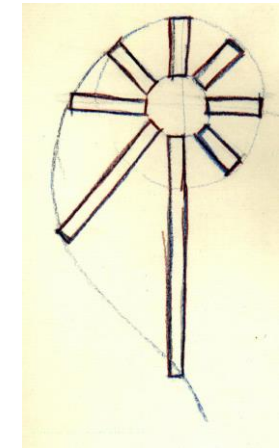
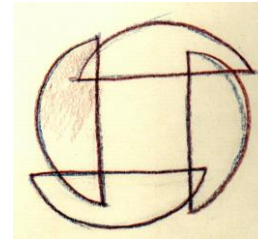
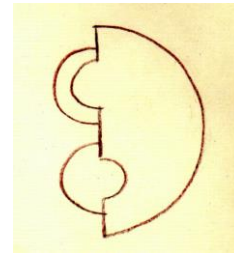
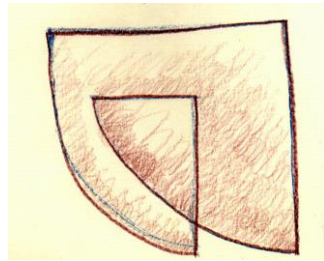
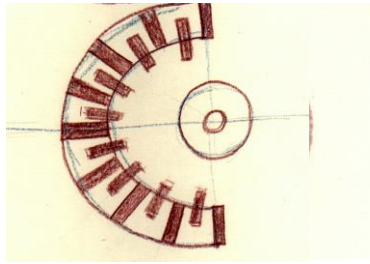

### The Circle

Social.

People group in circles.

Gradual and non storage.

## Concept 1

Elements that could in some way unify the object and space. The steel rod stands up into the space. The hanging seat elements from the curved steel emphasizing the whole space.

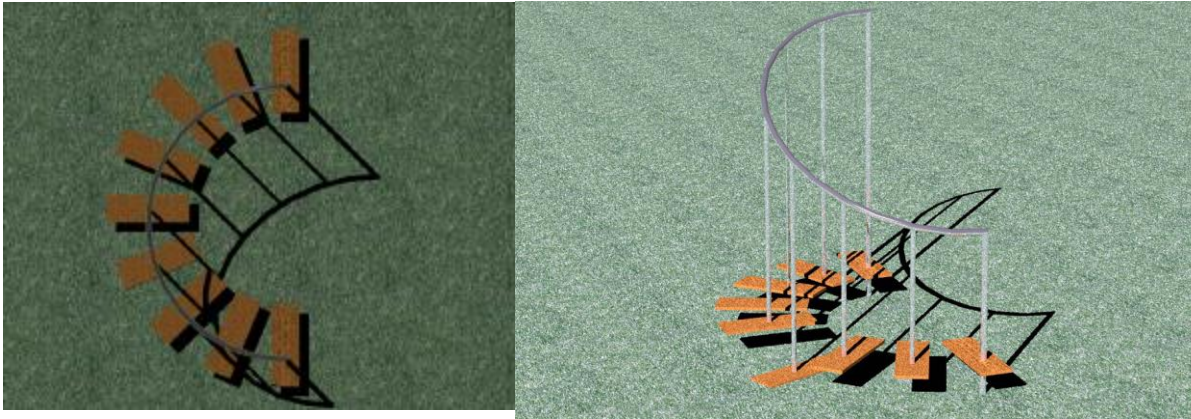

The curved seats giving it a sense of movement

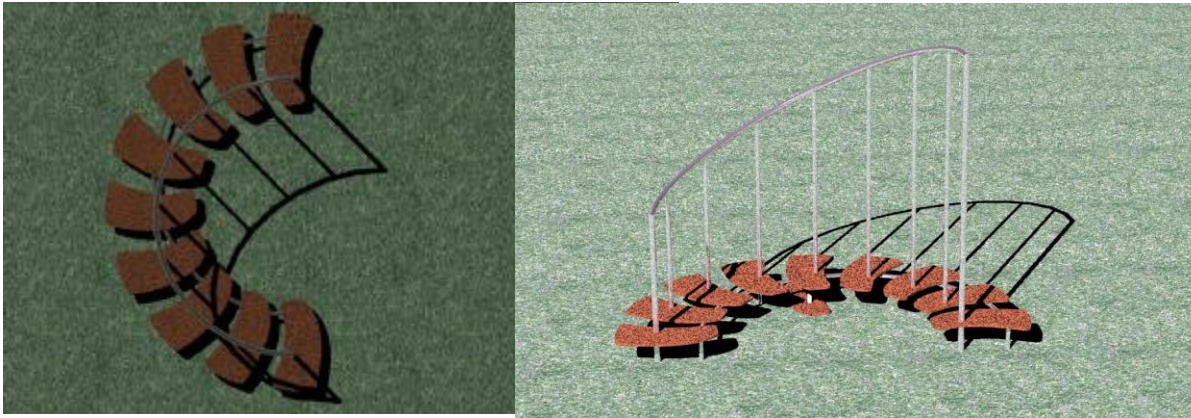

The variation in seat heights. The seats moving in an opposing curve to that of the steel rod.

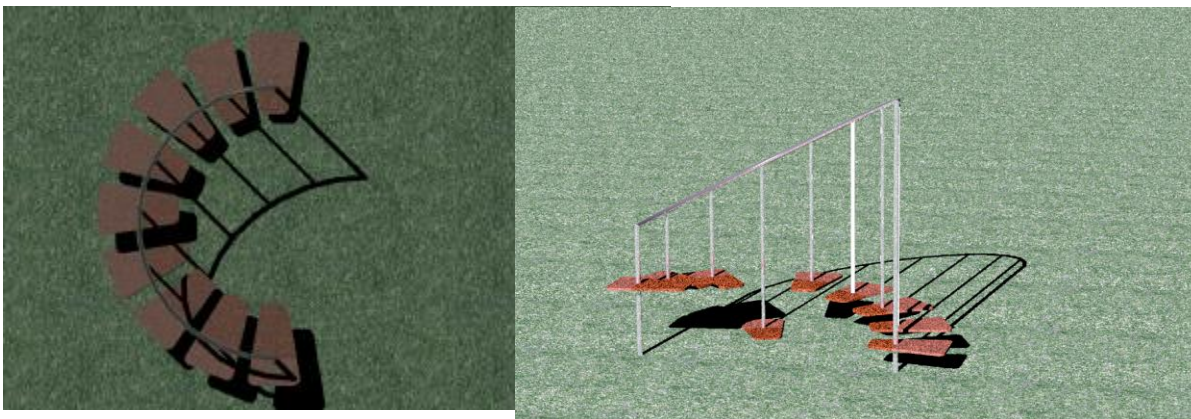

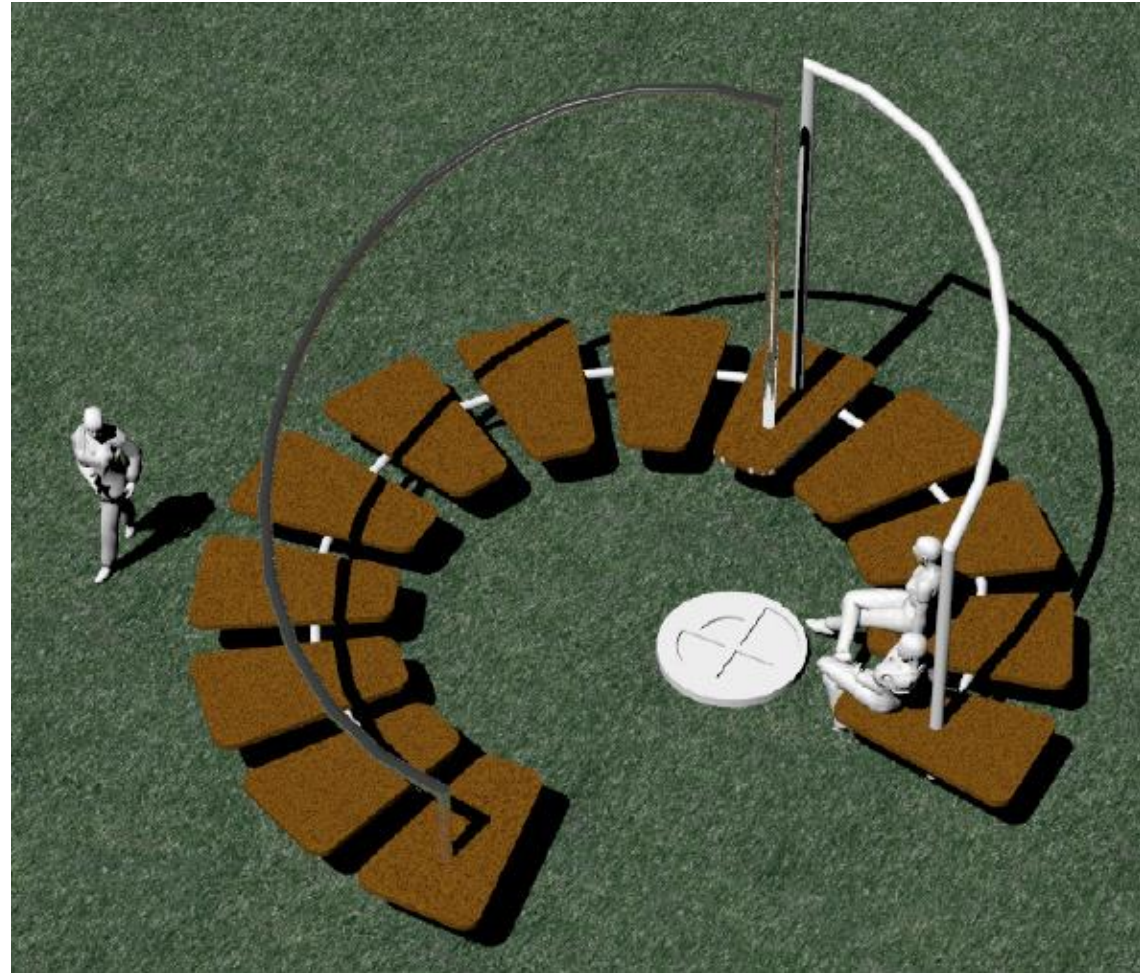
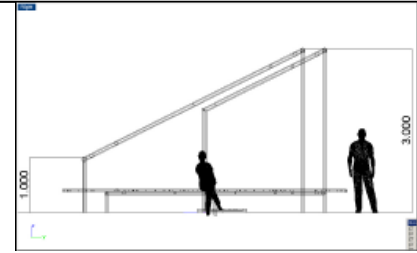

The curved steel rod encloses the space above the seats. The seats are bottom supported giving the form more stability and balance.

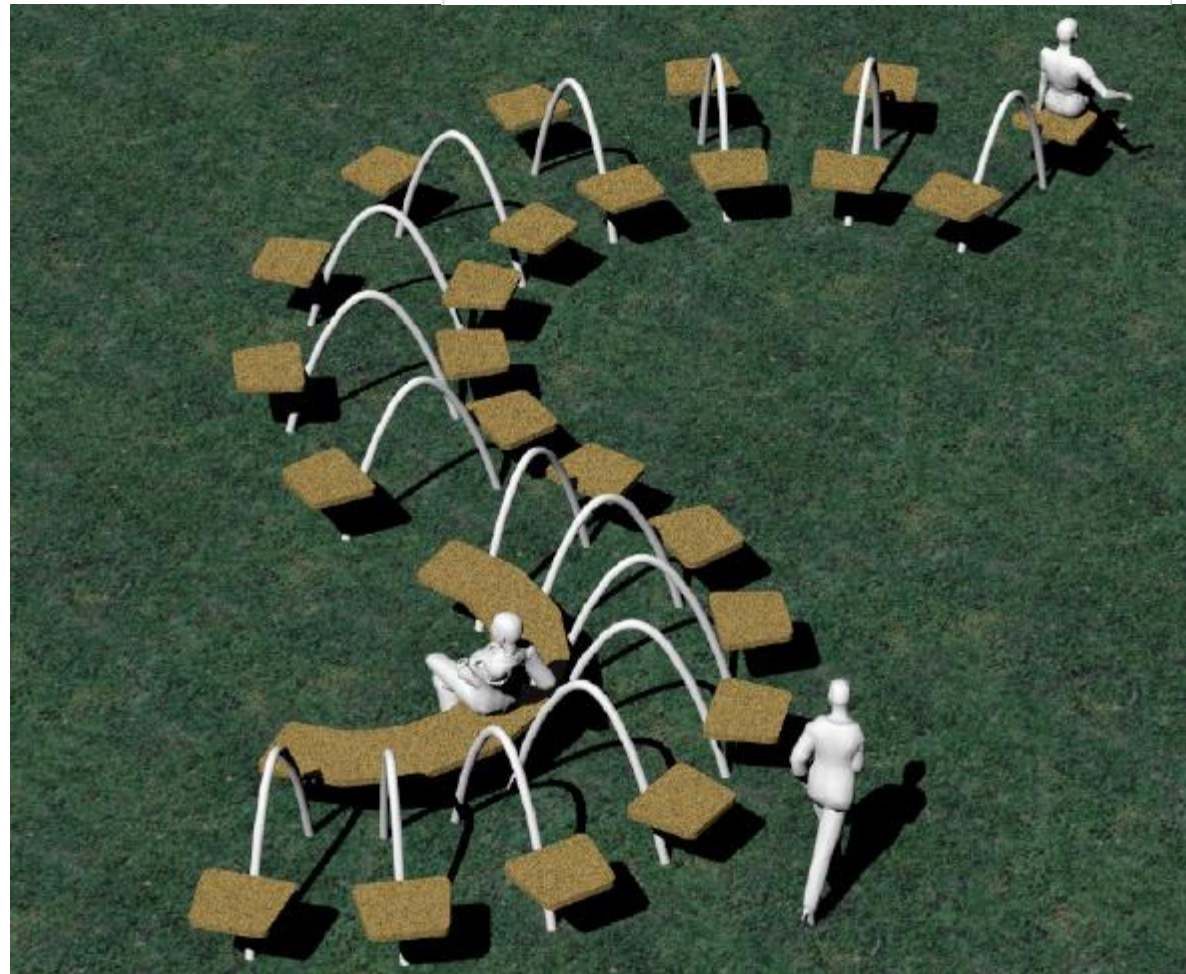
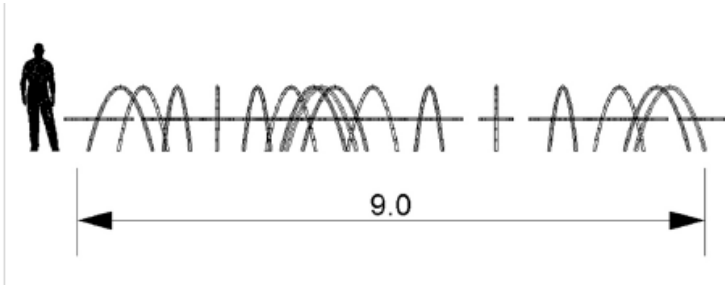

Repetition of a basic element that creates the aesthetics of movement in space as one moves along the curve from one end to the other.

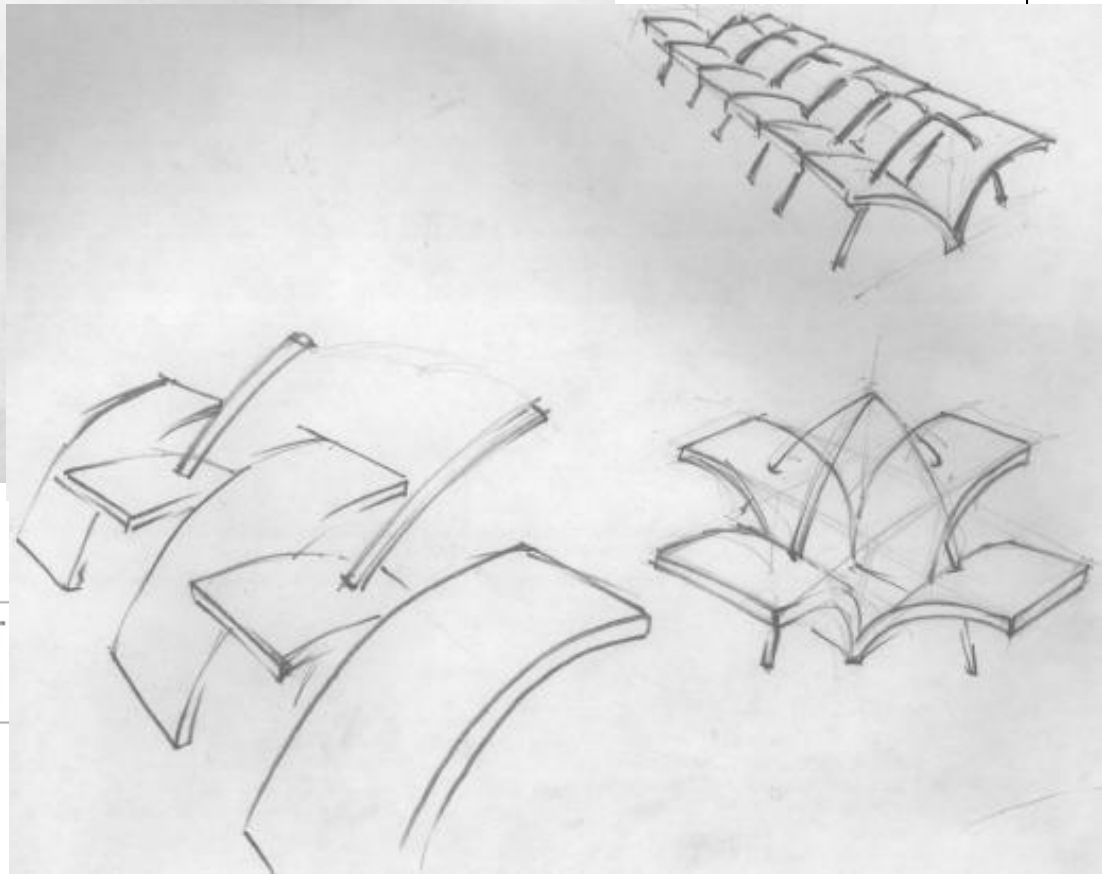
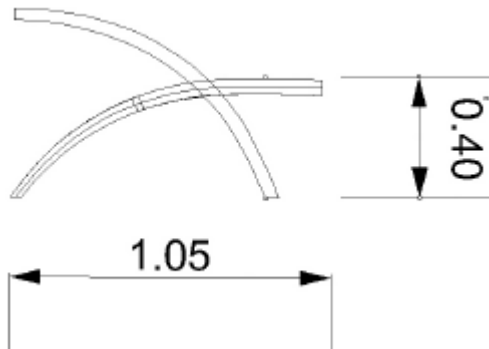
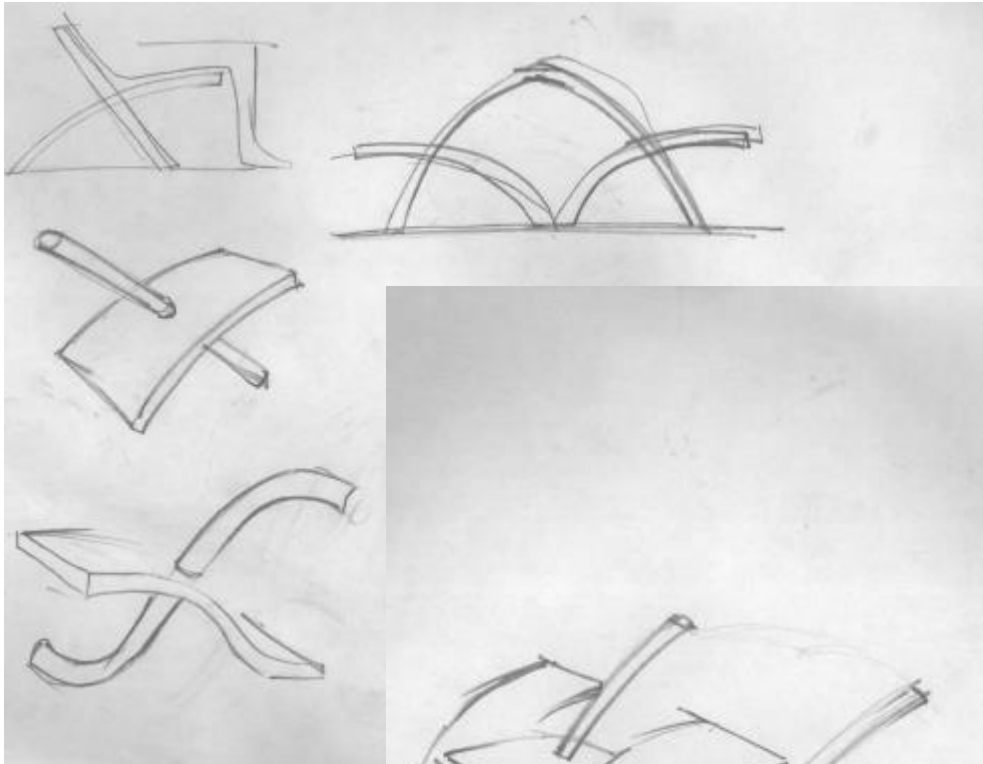

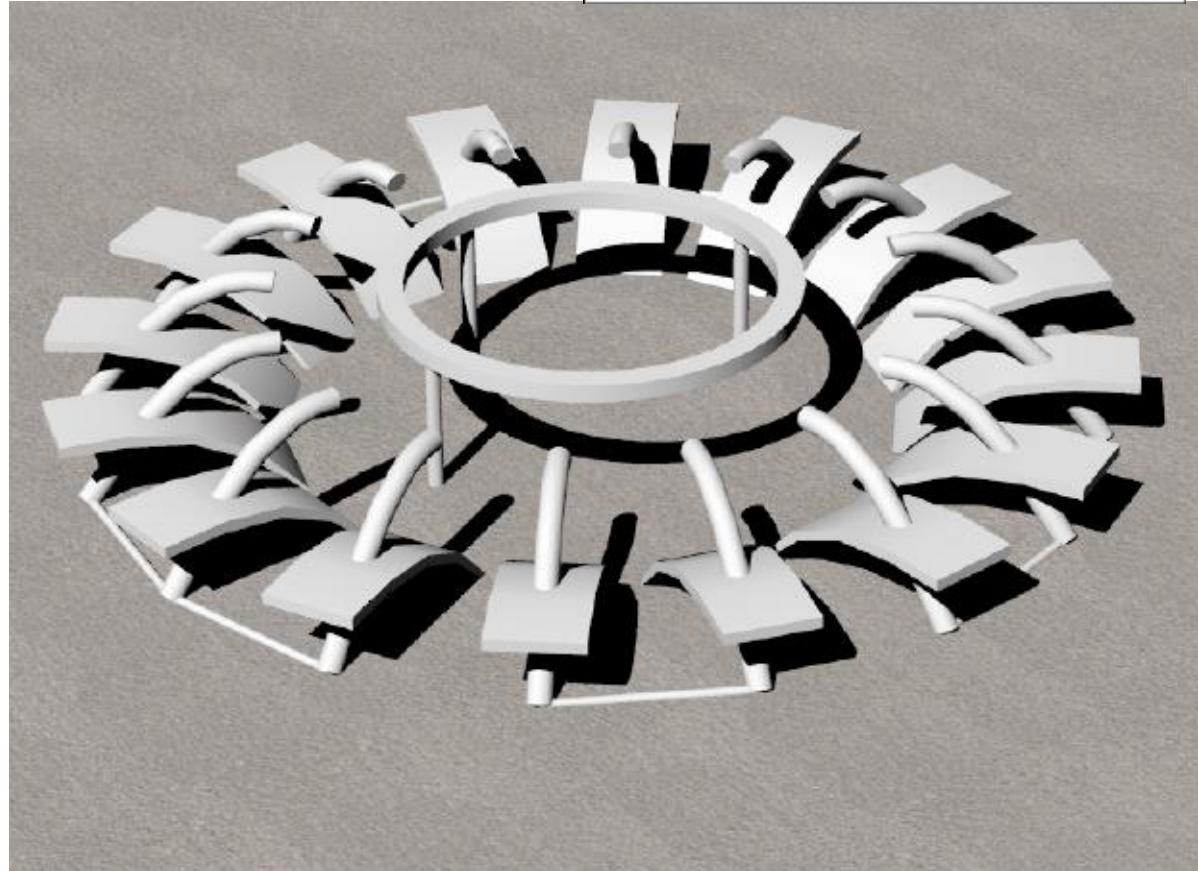
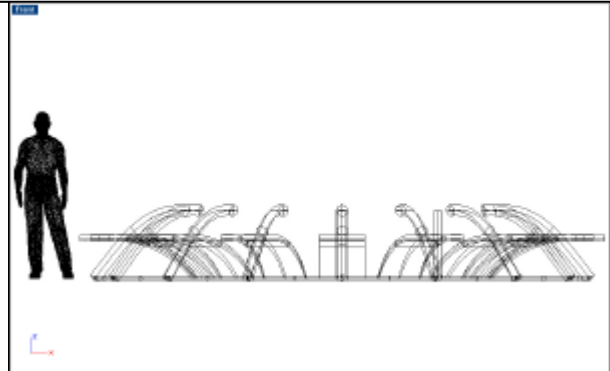



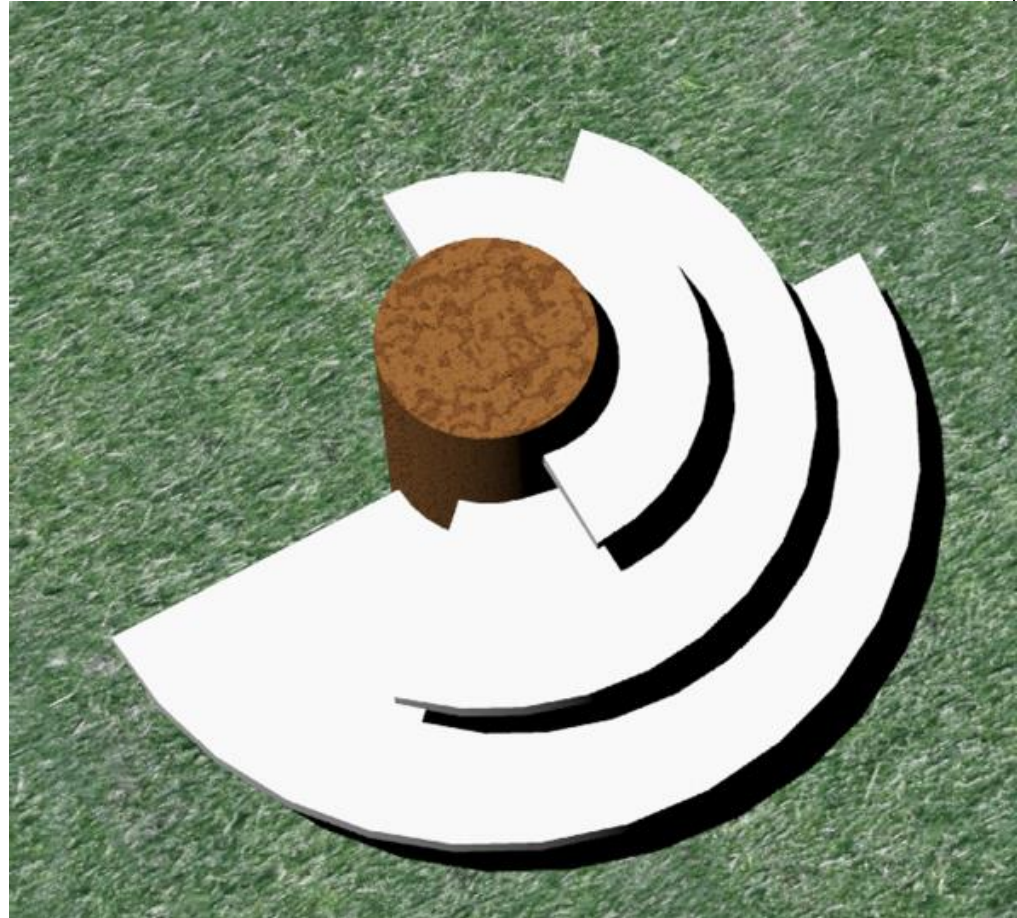
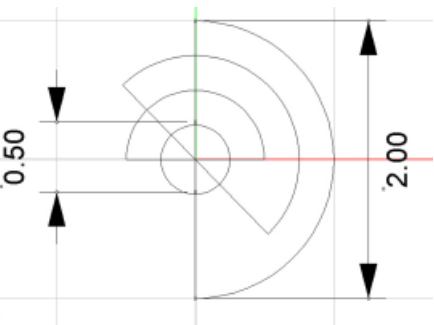
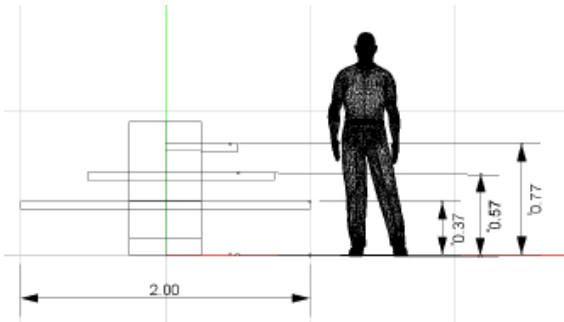

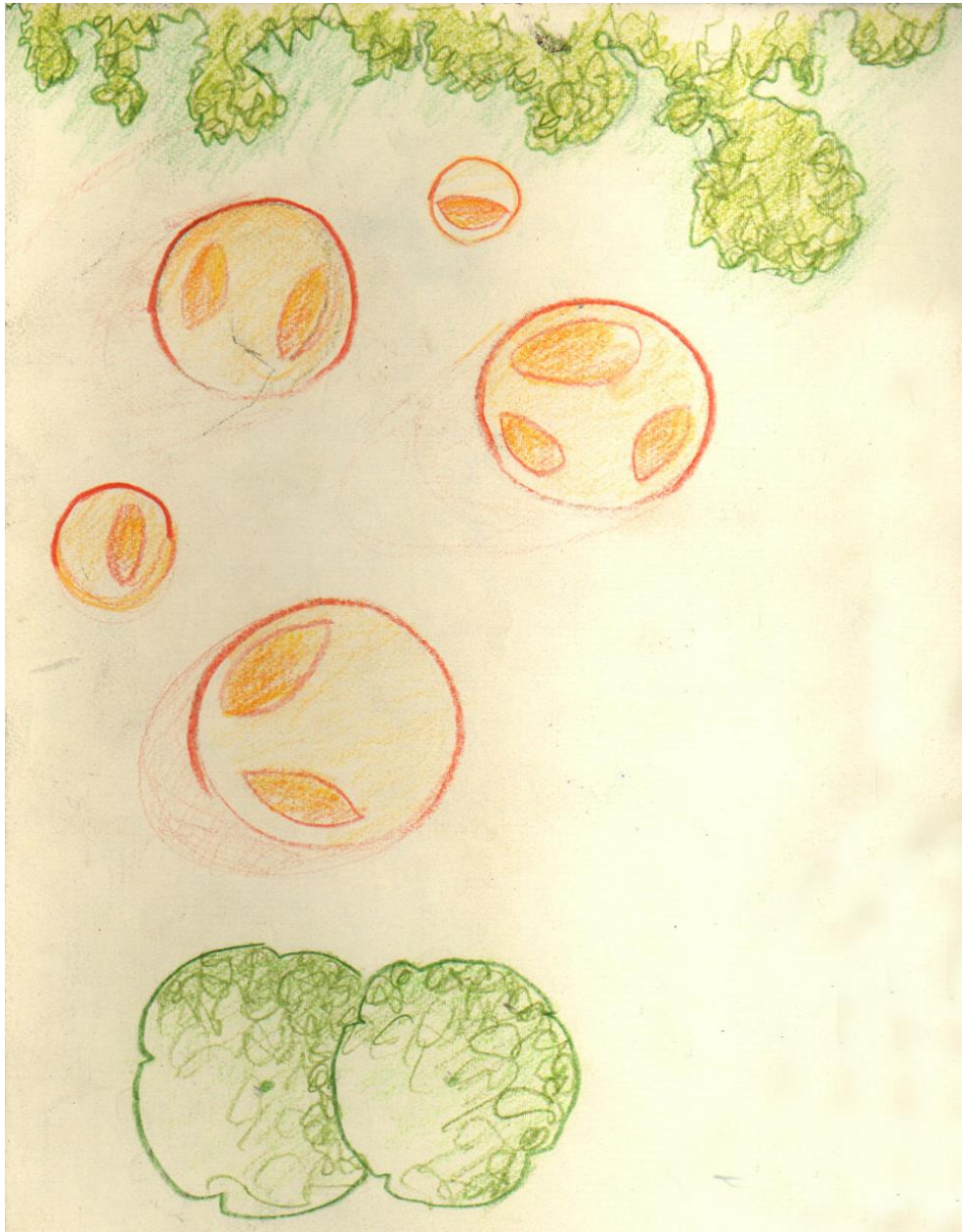

Form that arises based on how people group and interact.

There is a movement and force depending on how people use space.

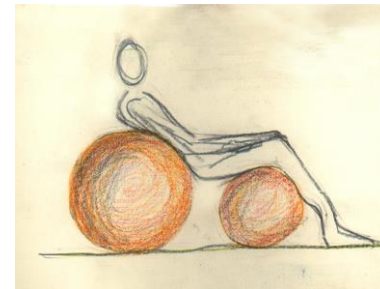



## Interaction

The act of balancing

The composition created by the 3 spheres

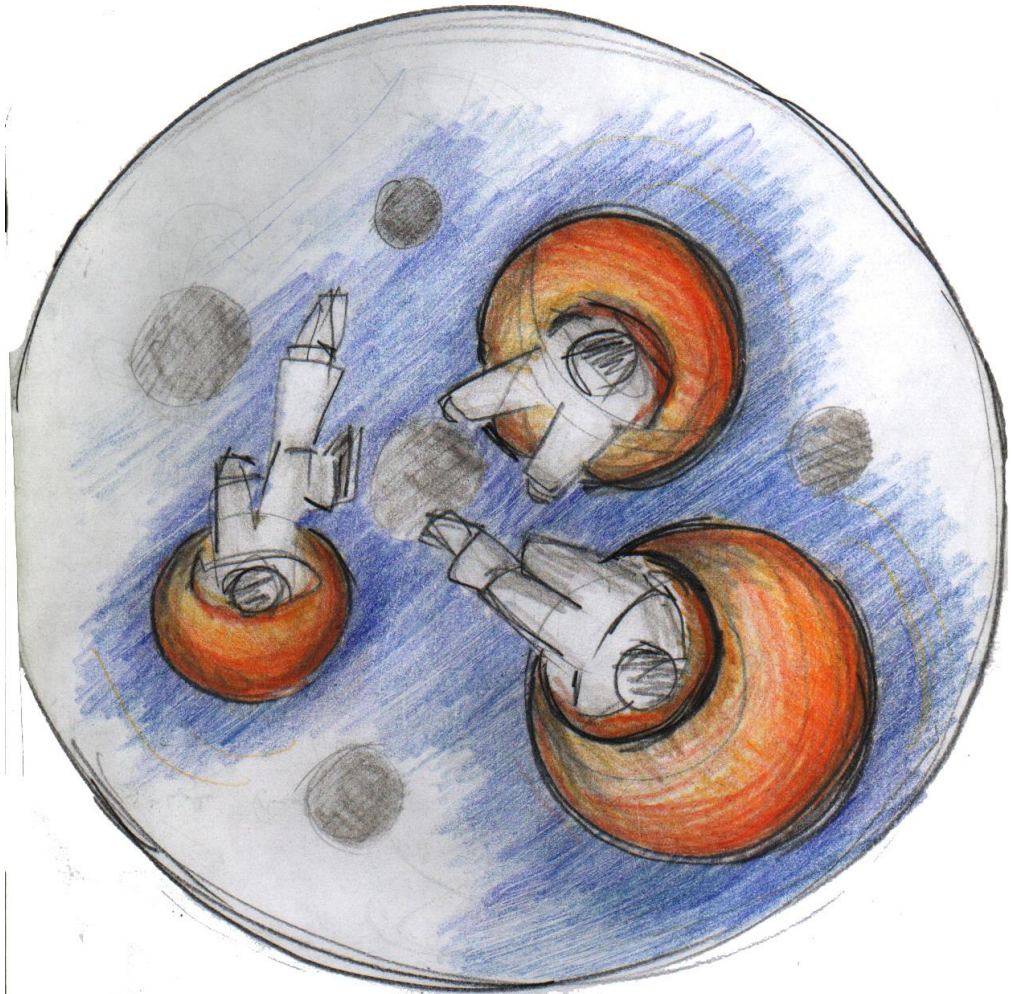
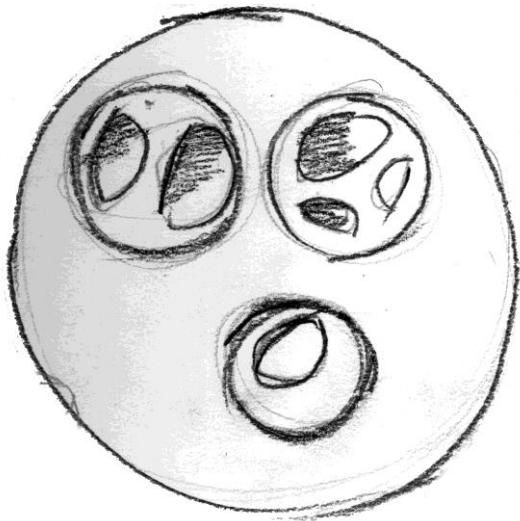

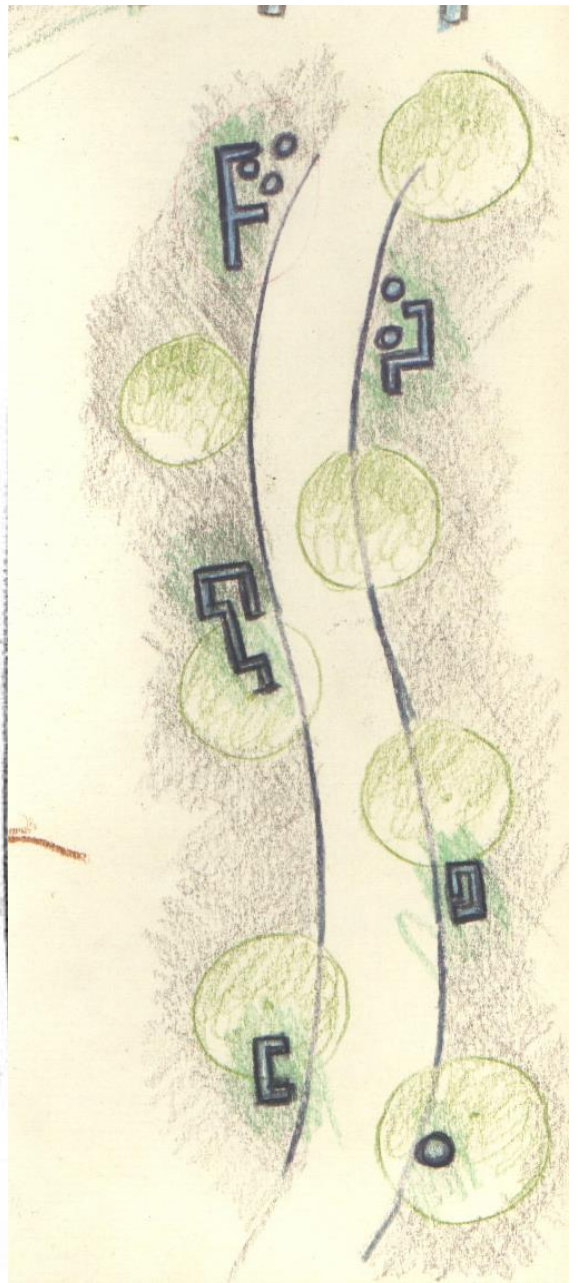
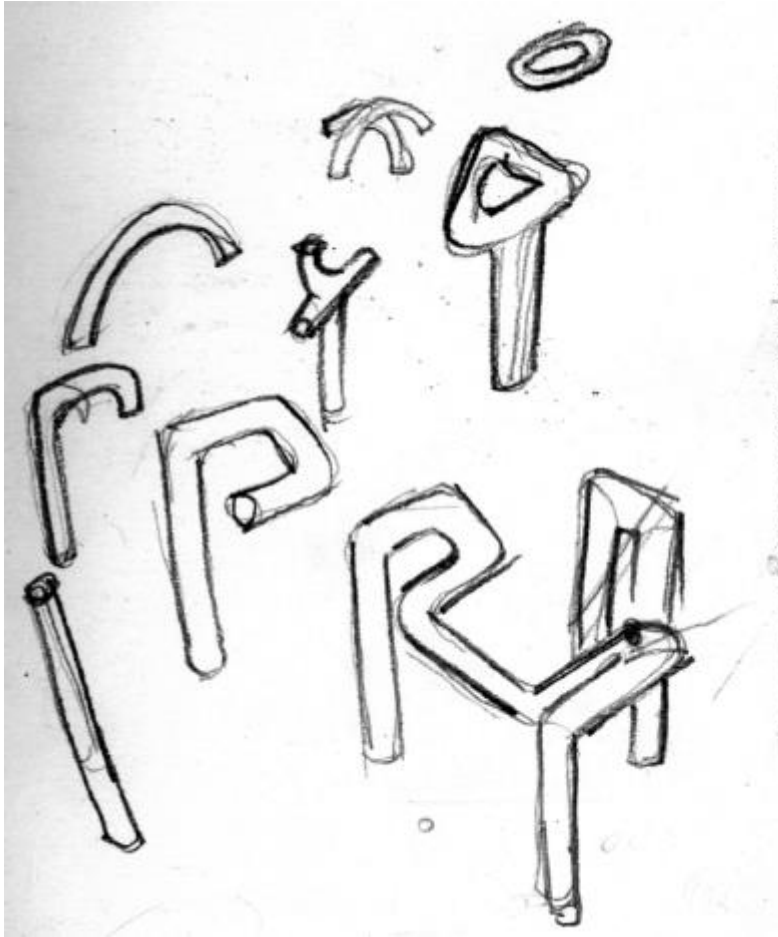

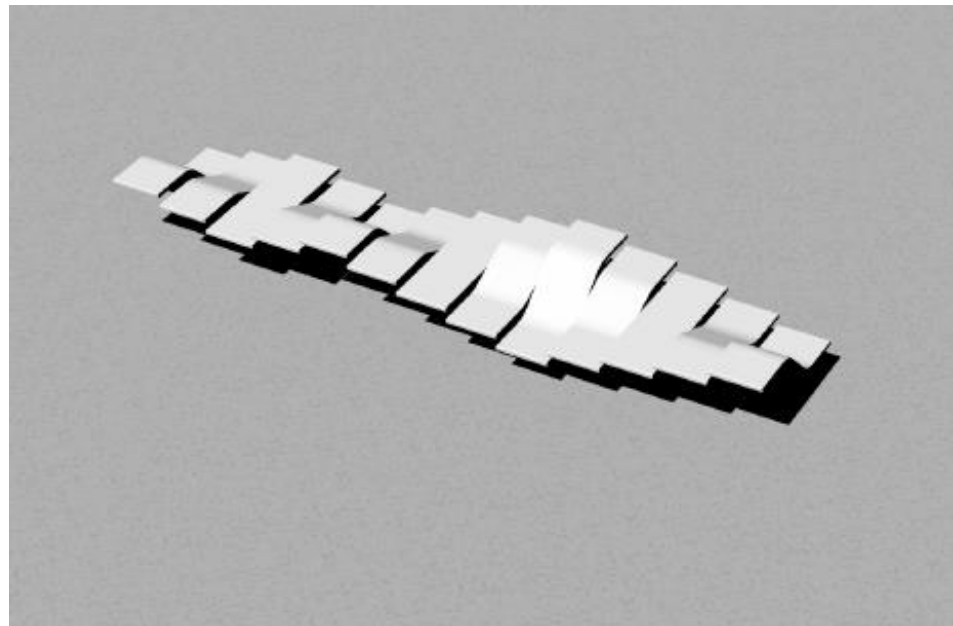

A resting place exploring an image of nature, the wave

How detailing could affect a form.

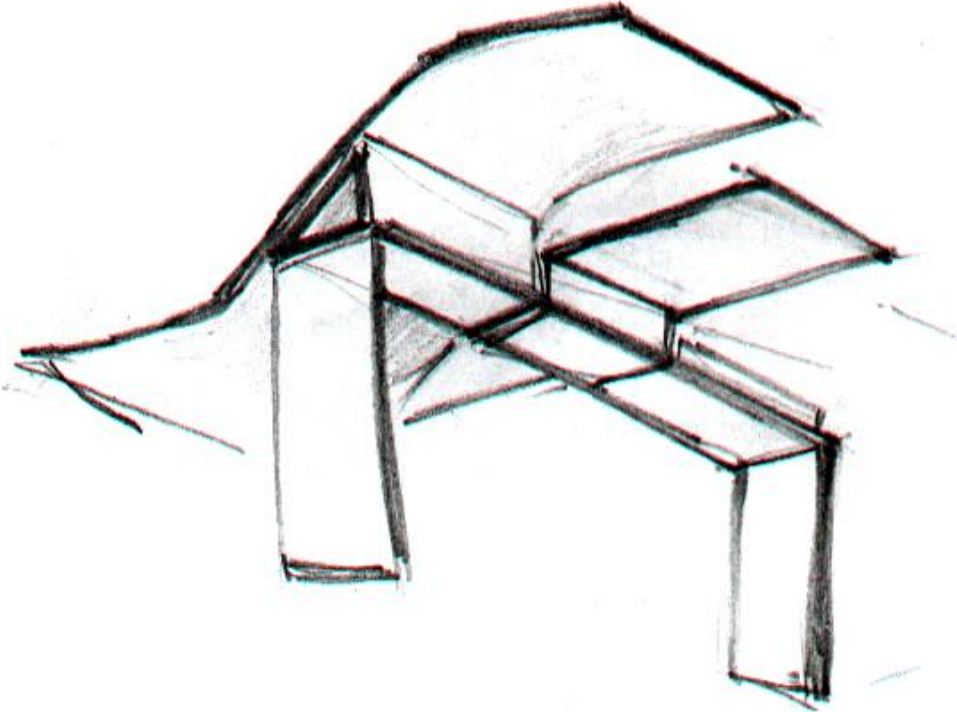
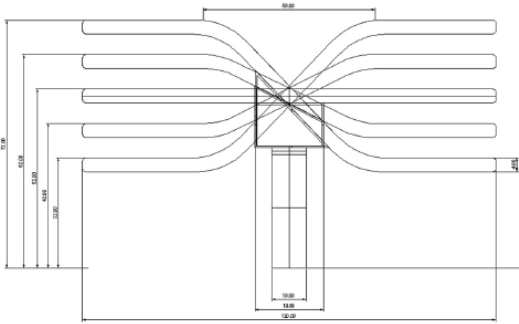

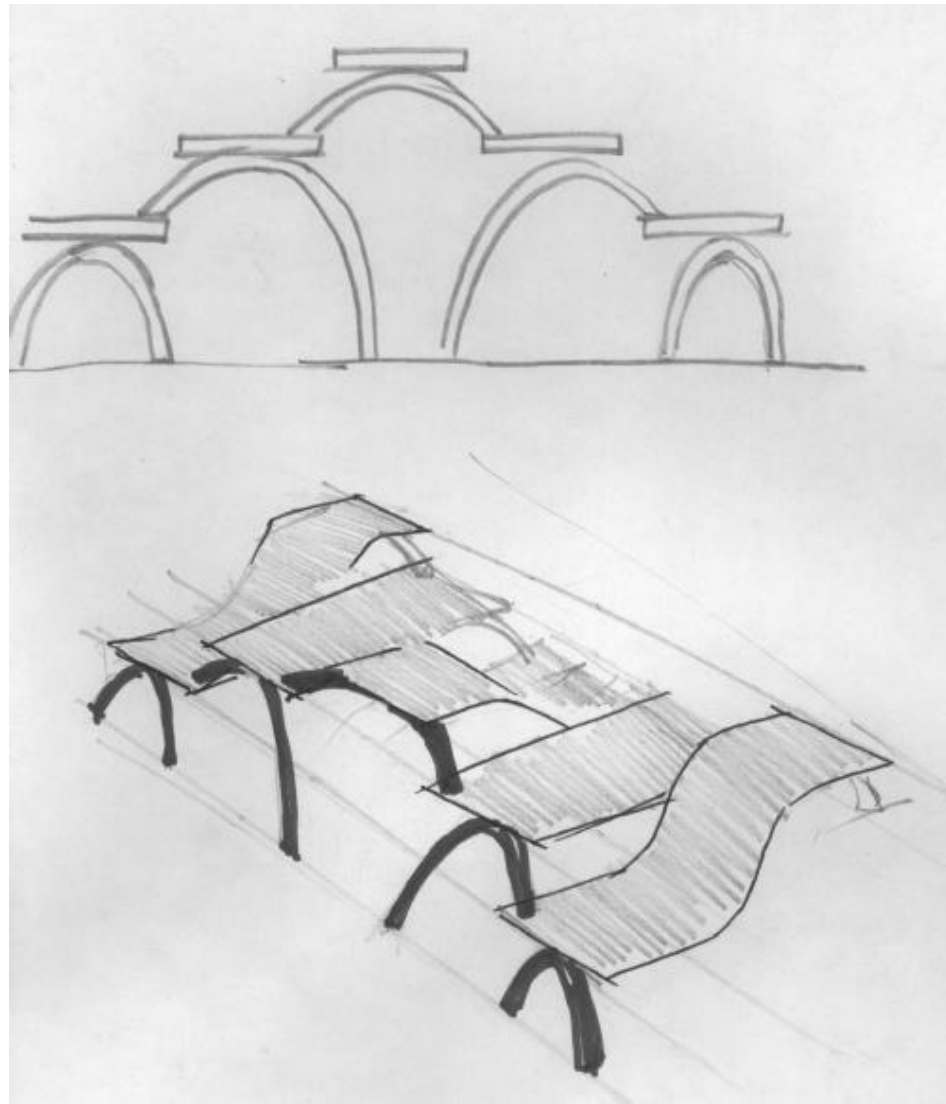

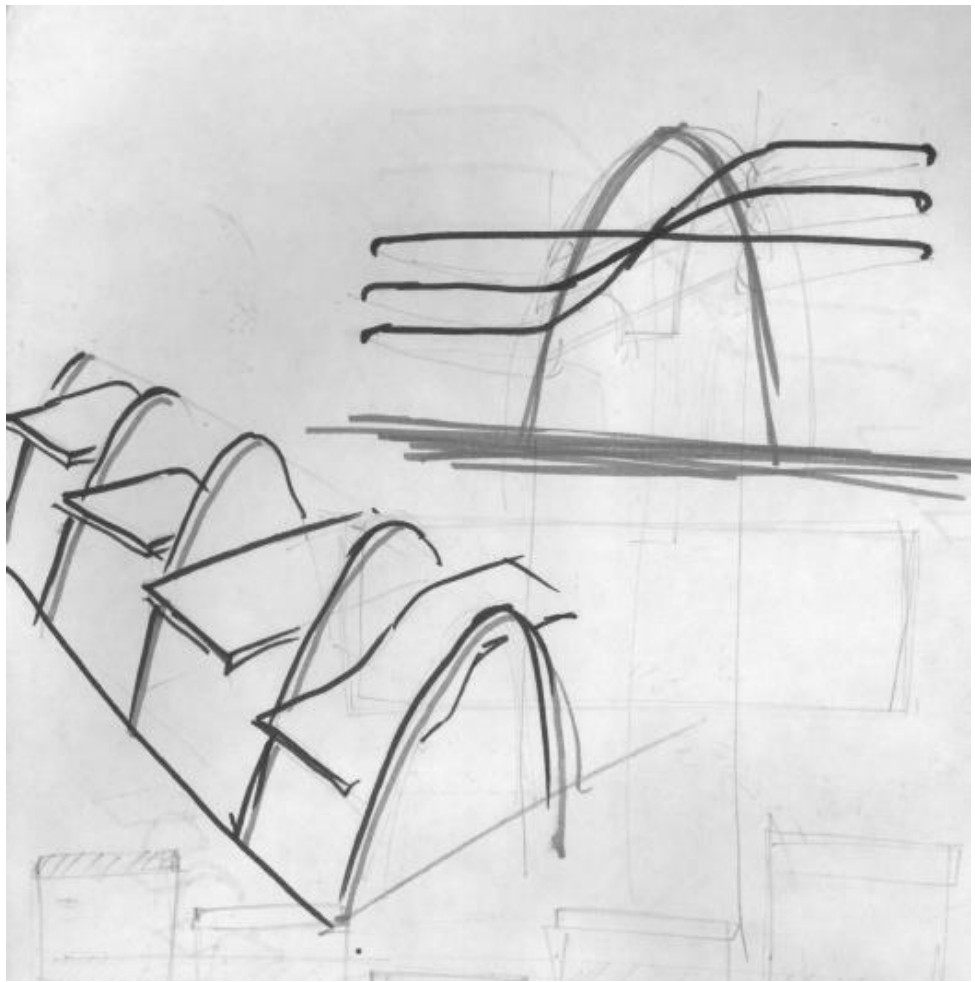

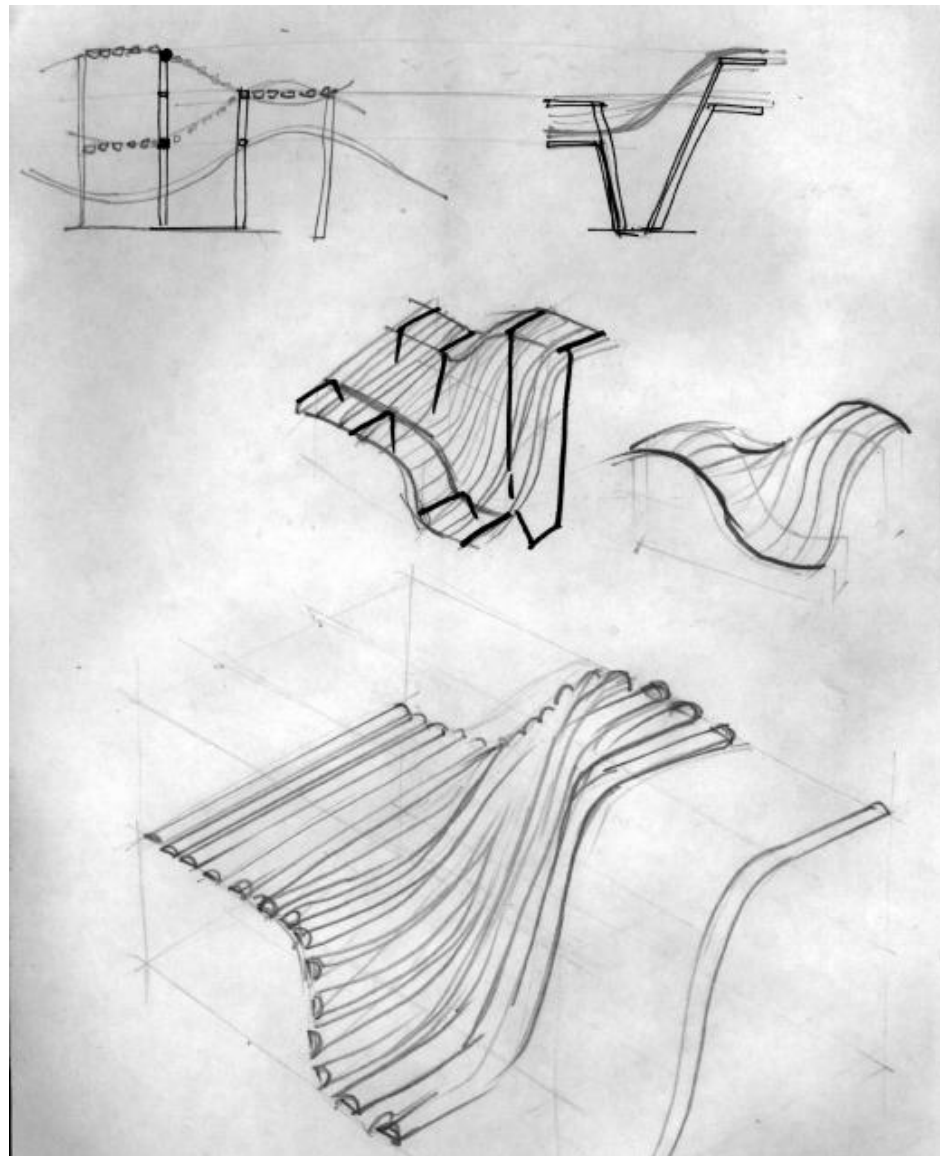

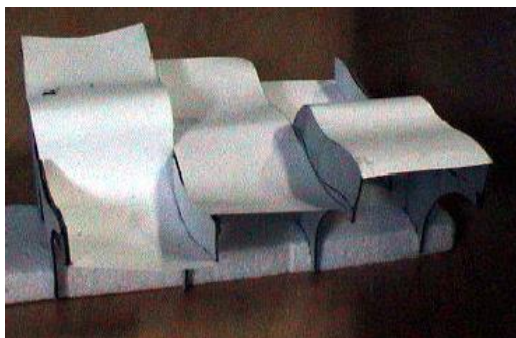
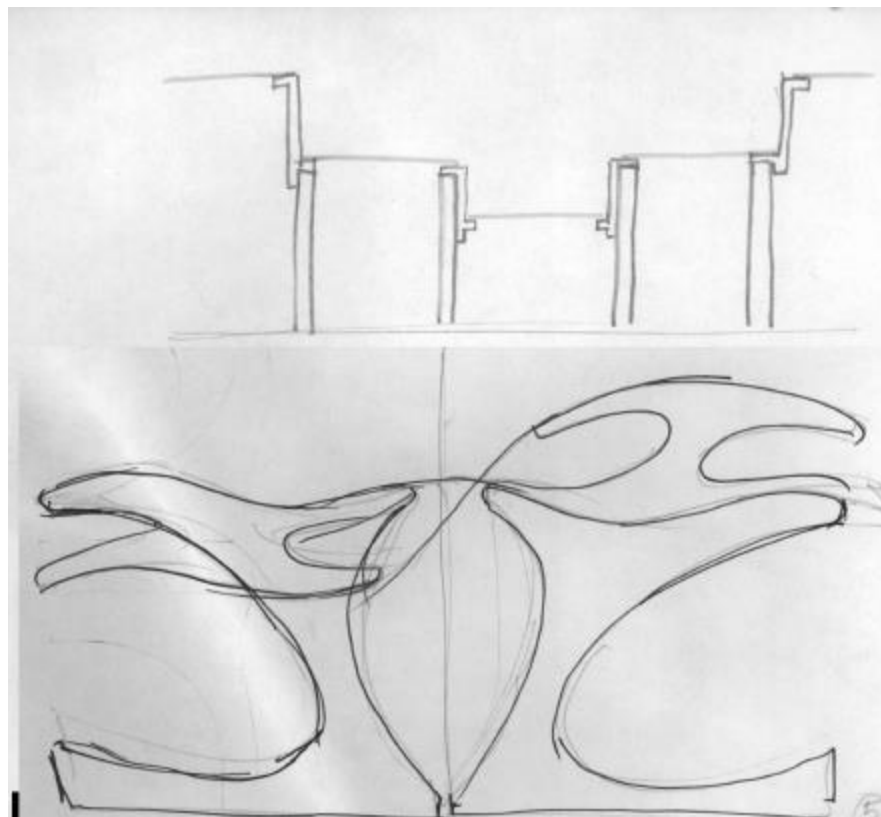
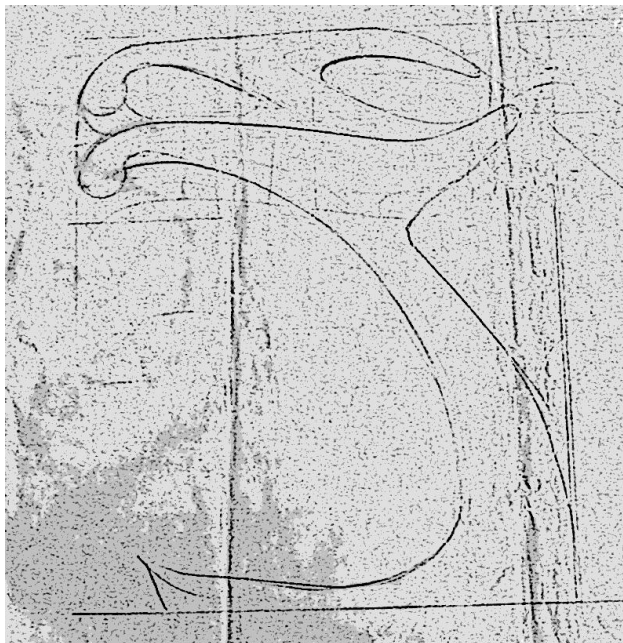

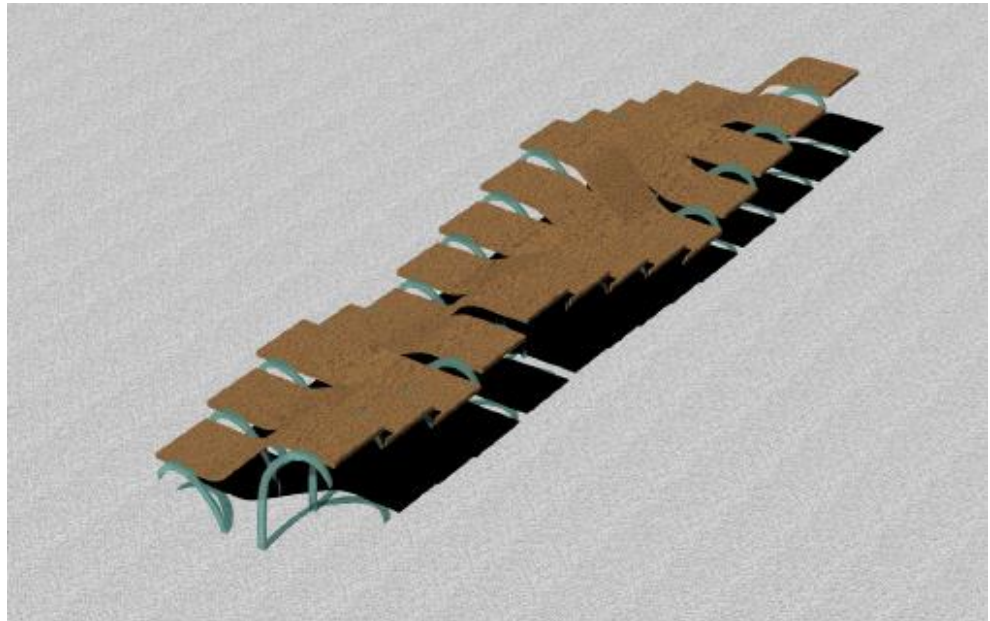
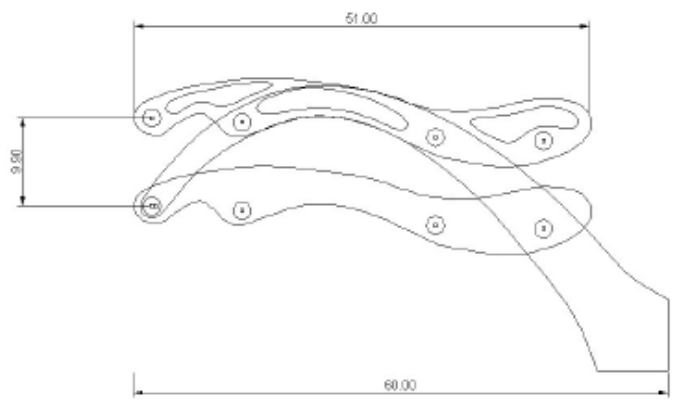

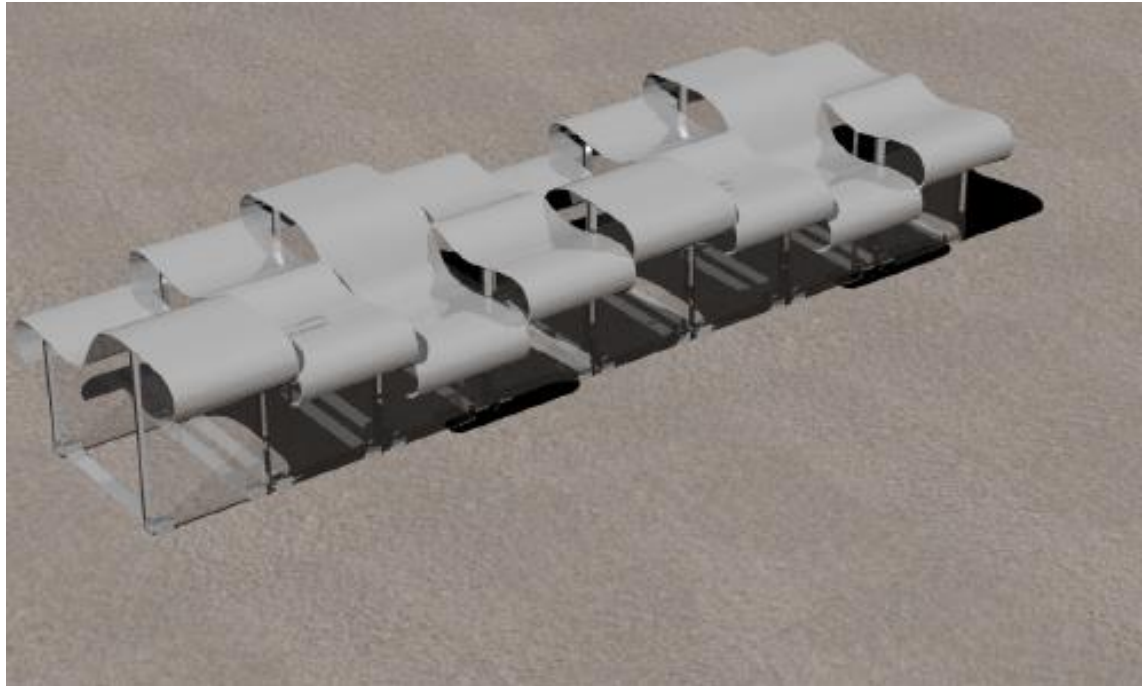
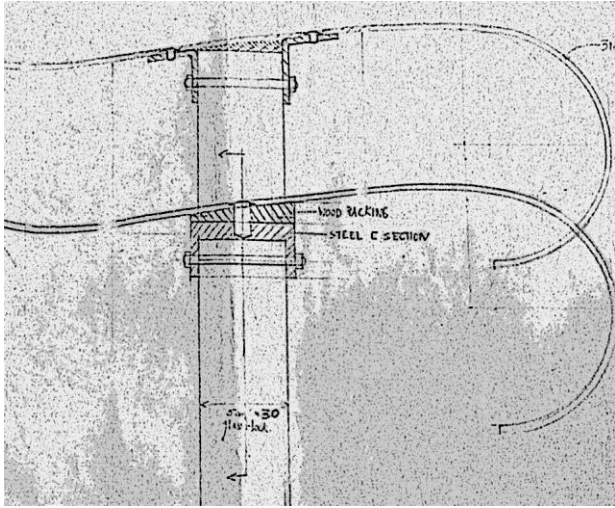



**The Wave**

Momentary ness



## The wave chunks

Intermediate.  
Modular elements.

Wave comes in chunks still is a part of the whole. In itself it is complete. All of them together they make the entire.

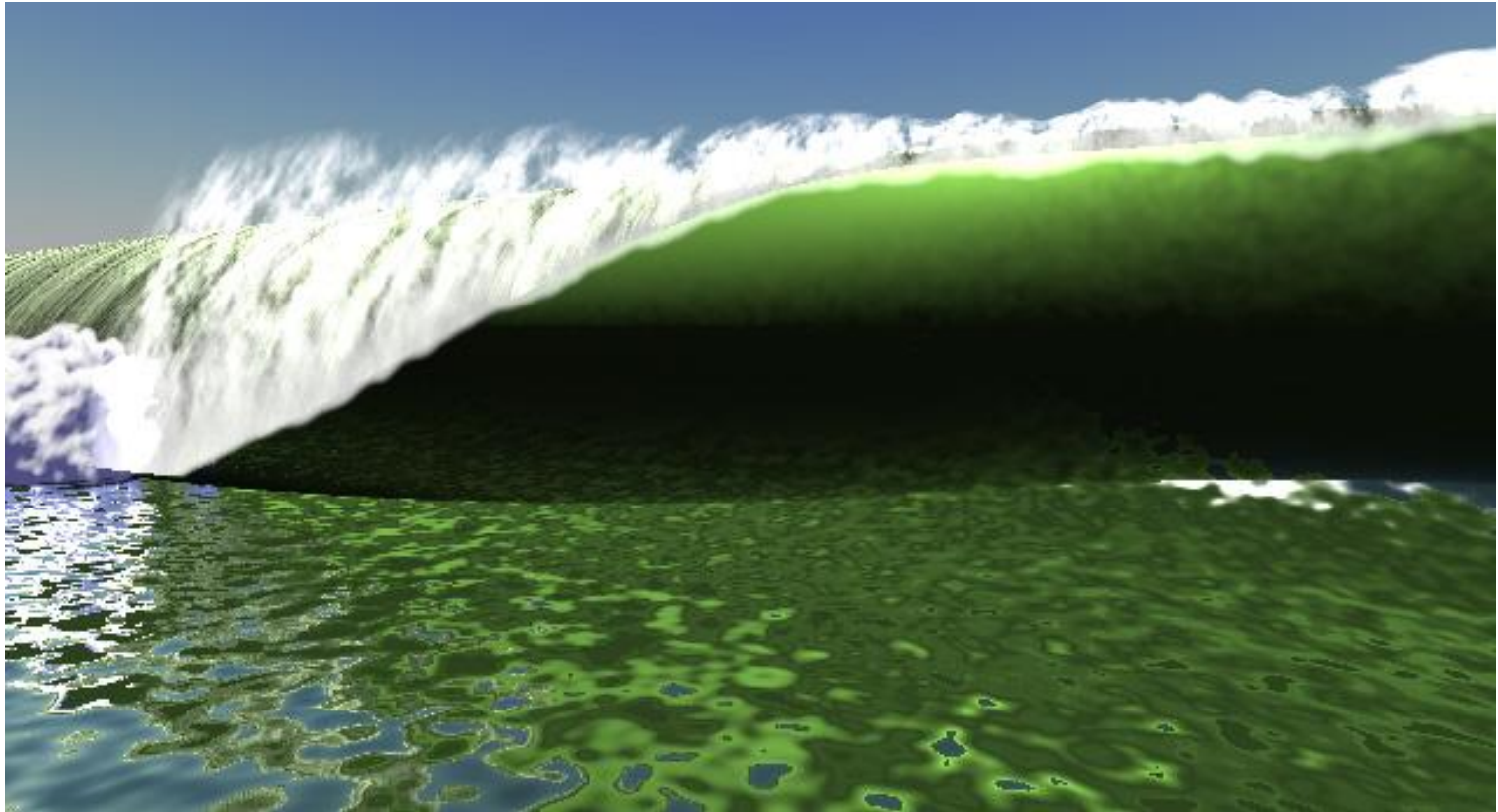

**Height variation**



## **Negative and positive spaces**

### **Colour**

Contrast  
imbibed form the surrounding.

### **Shades and shadows**

varying thickness of water.



## The Curves

The varied curves creates randomness.  
But the curves have perfect definition and balance.  
Gradual and abrupt.

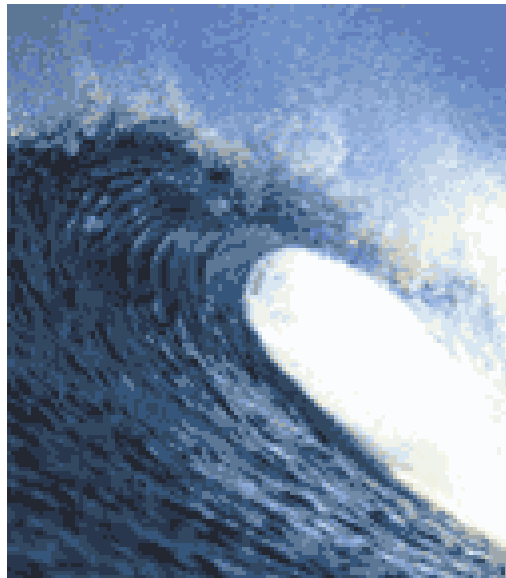

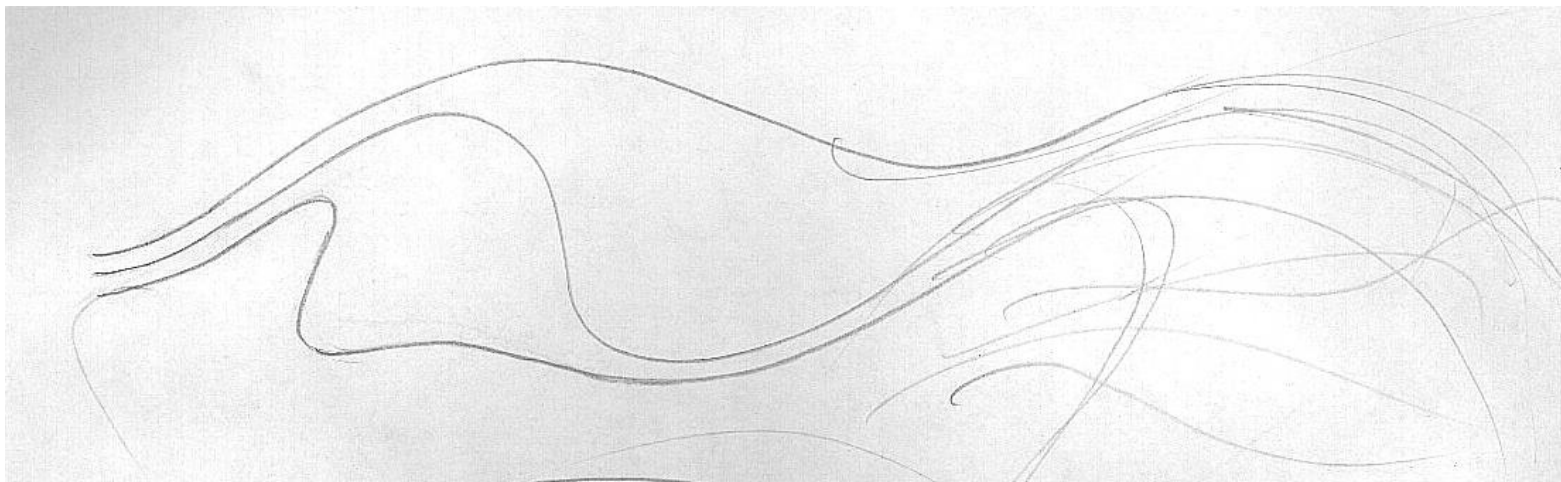

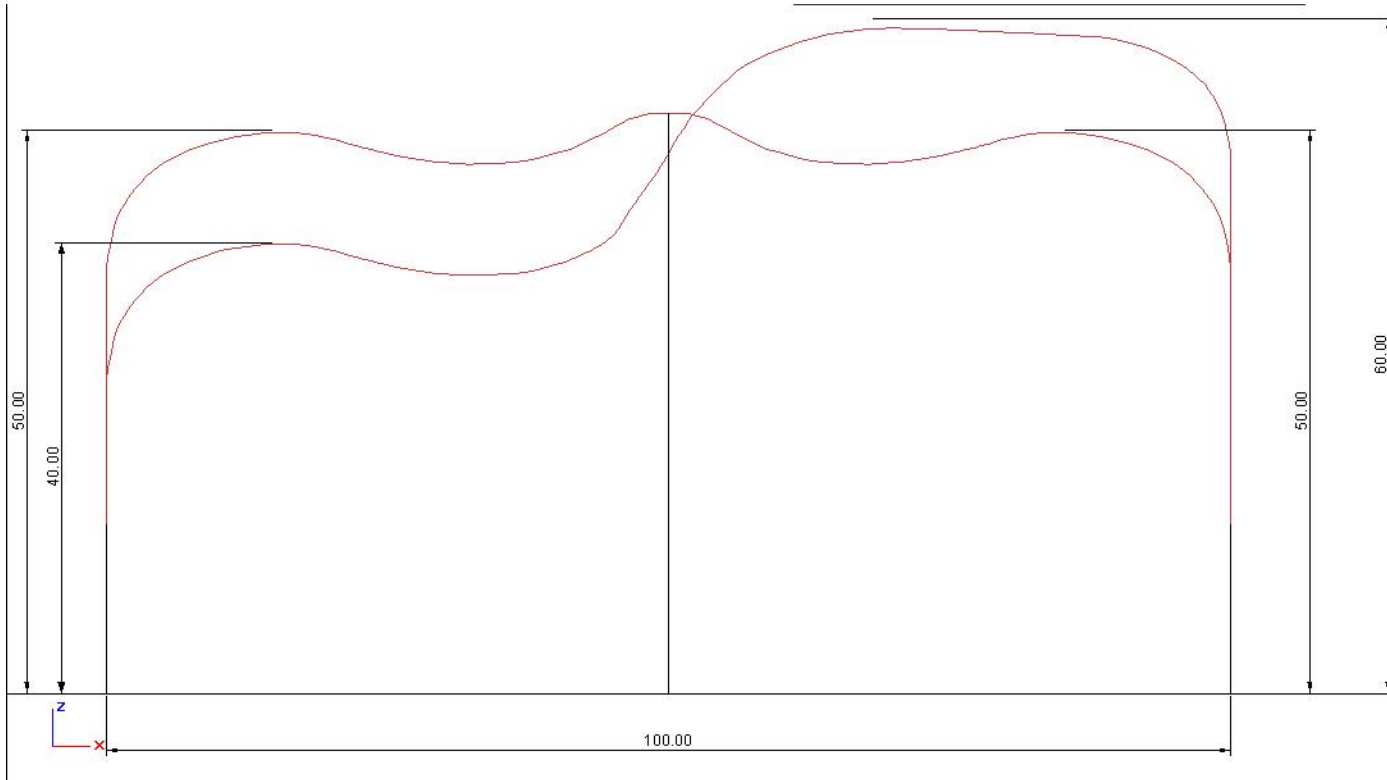
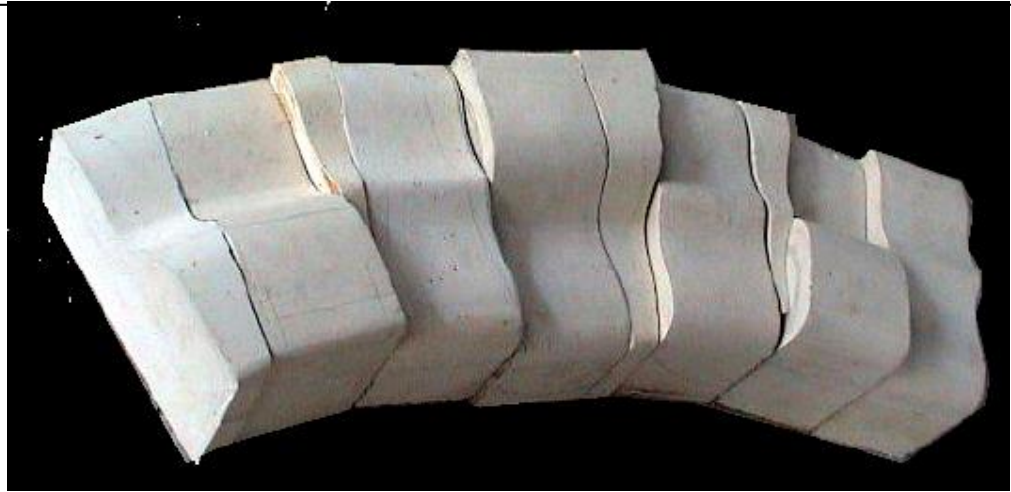

The form had to be a whole in itself

Balance  
Curves from the ground rising and falling.



There is an imbalance. The imbalance that creates the force of wave.

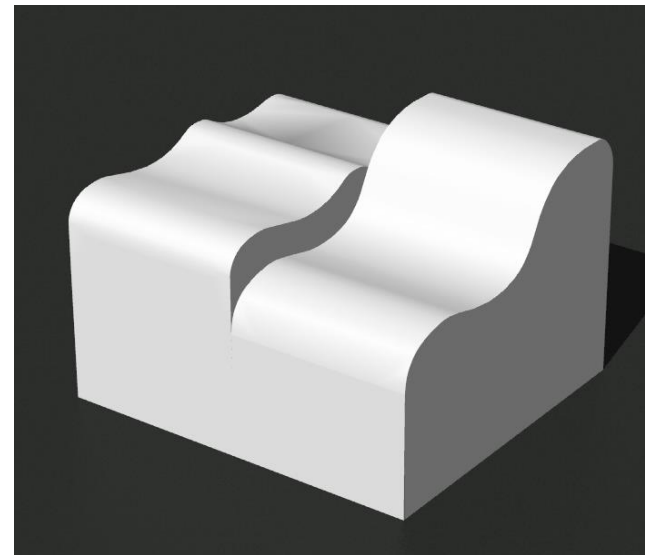
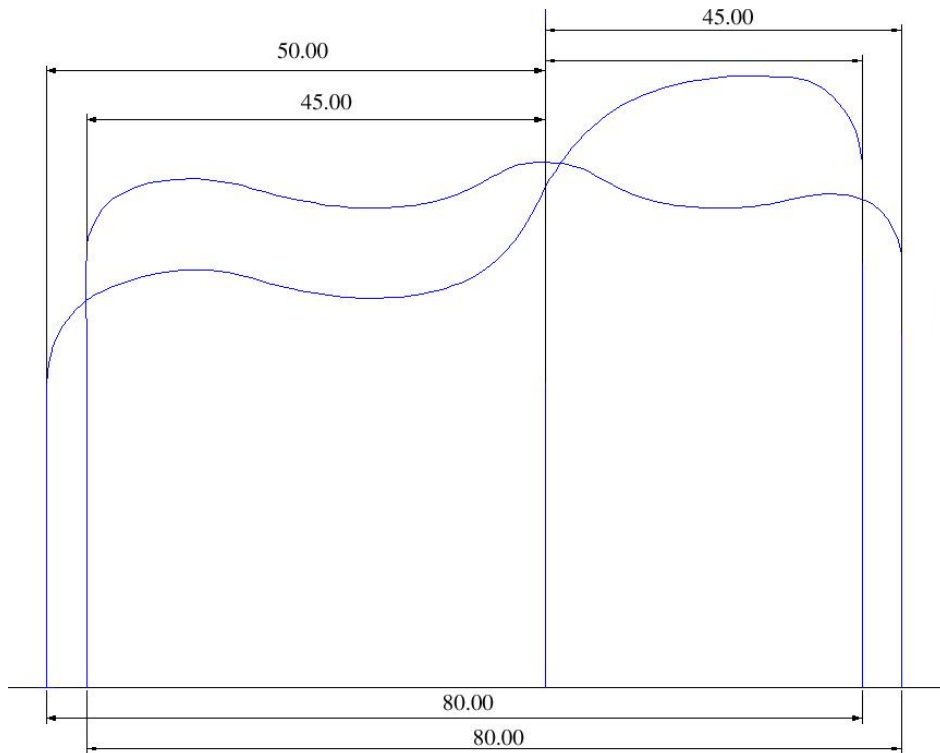

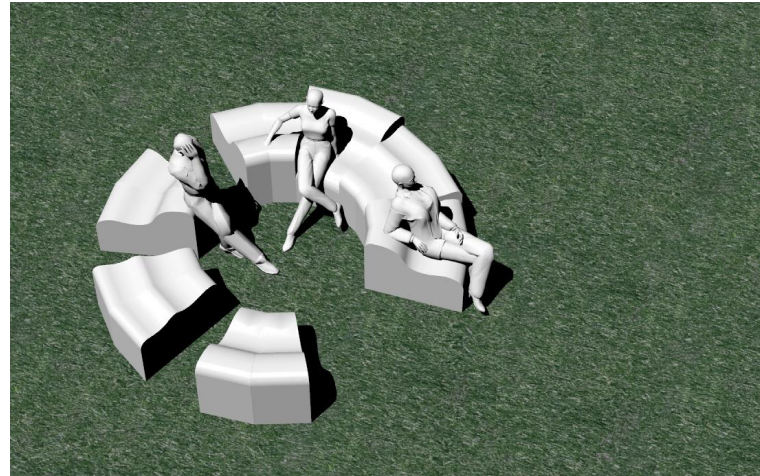
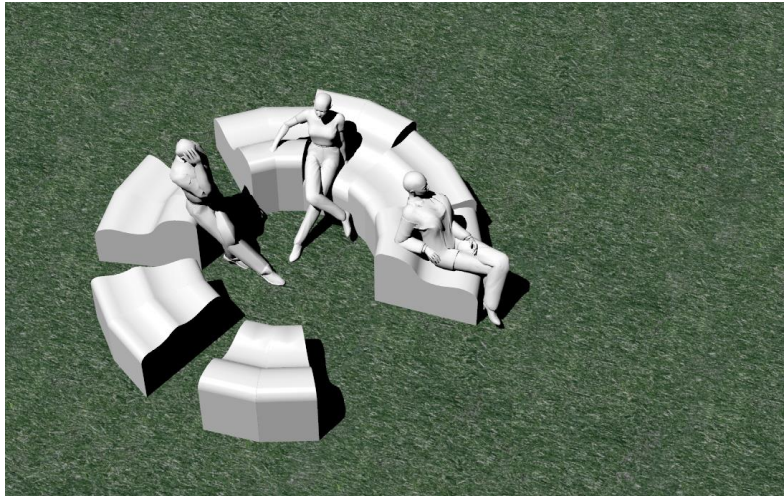
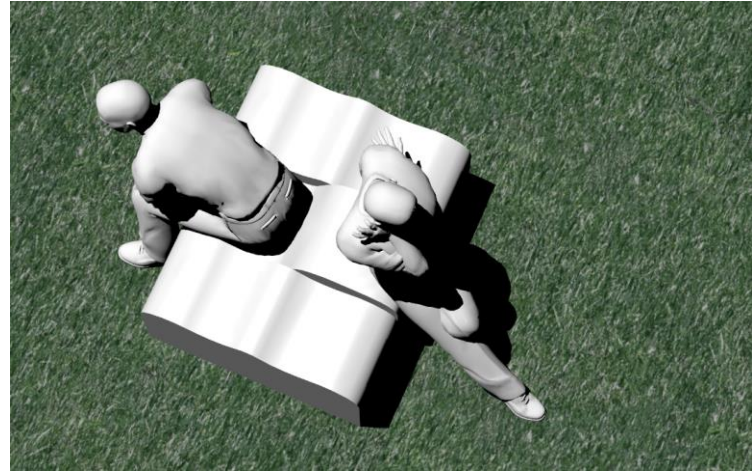
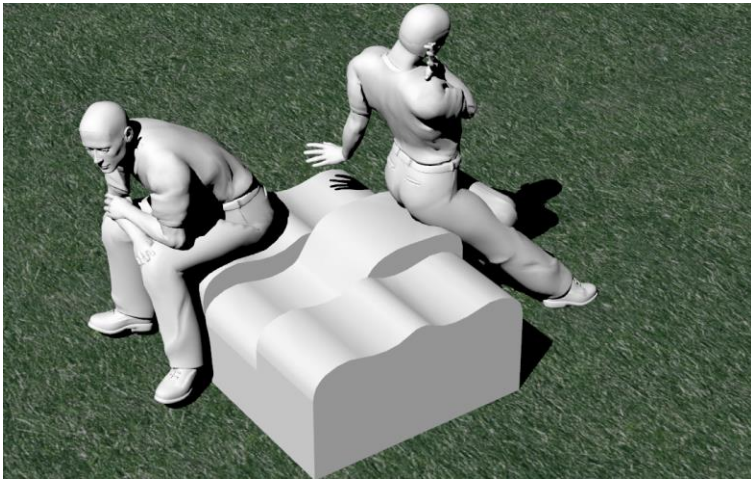

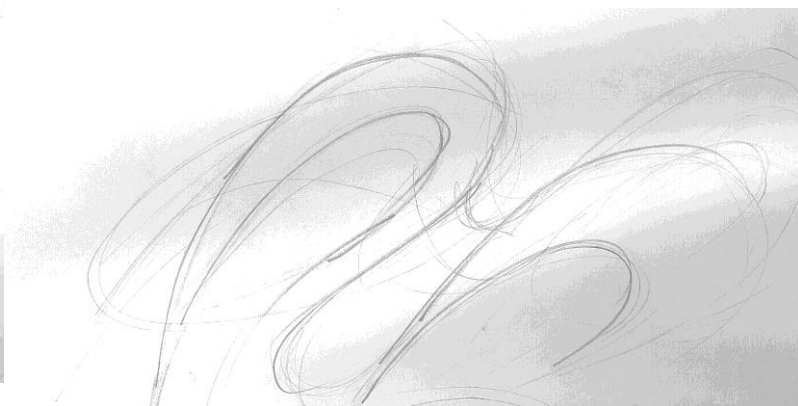
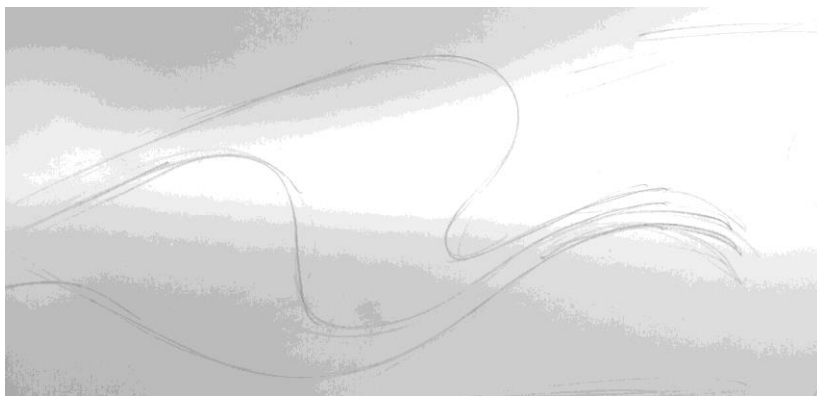
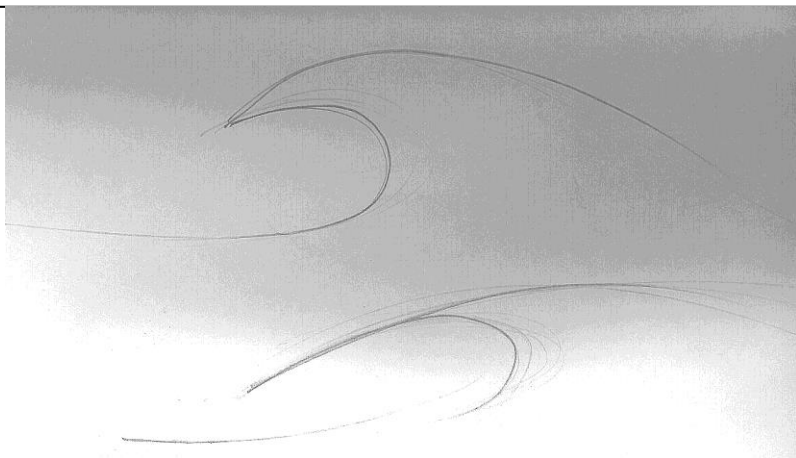



combined data

incline seat pan angle - 2 degree 14 degree  
backrest (most comfortable) 110 - 130 degree back rest angle

lumbar

lower lumbar 95% - 159 mm  
upper lumbar 5% - 246 mm

buttock to popletail

5% - 394 mm

height details percentile population

old

65+ 388.6mm 473.22mm

Adult

child



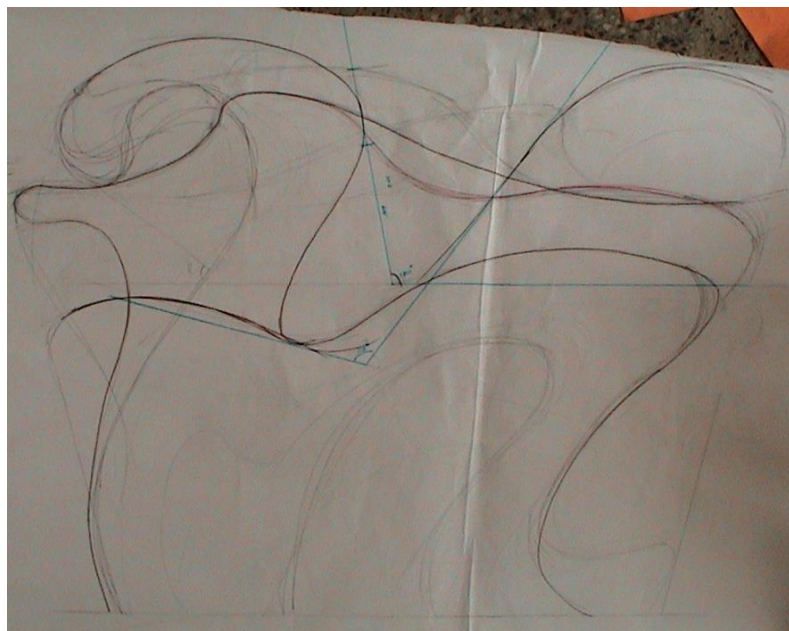
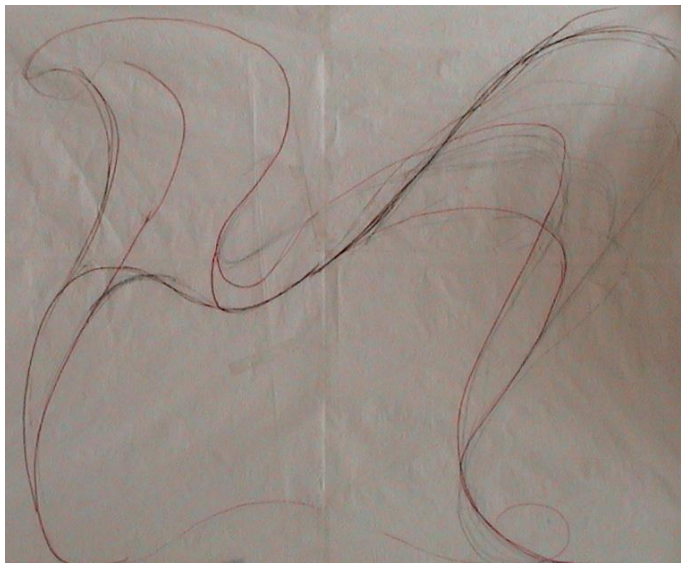

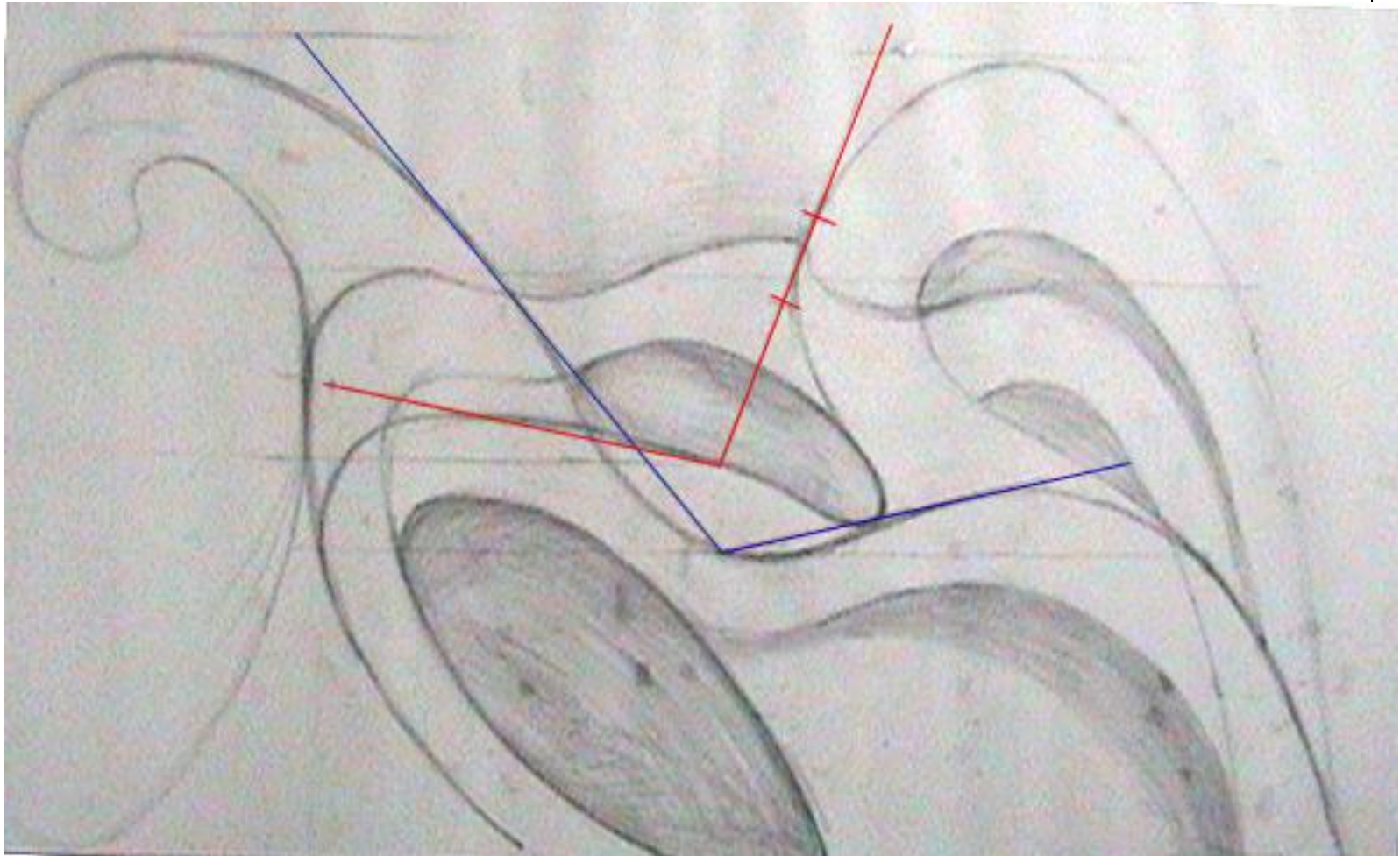

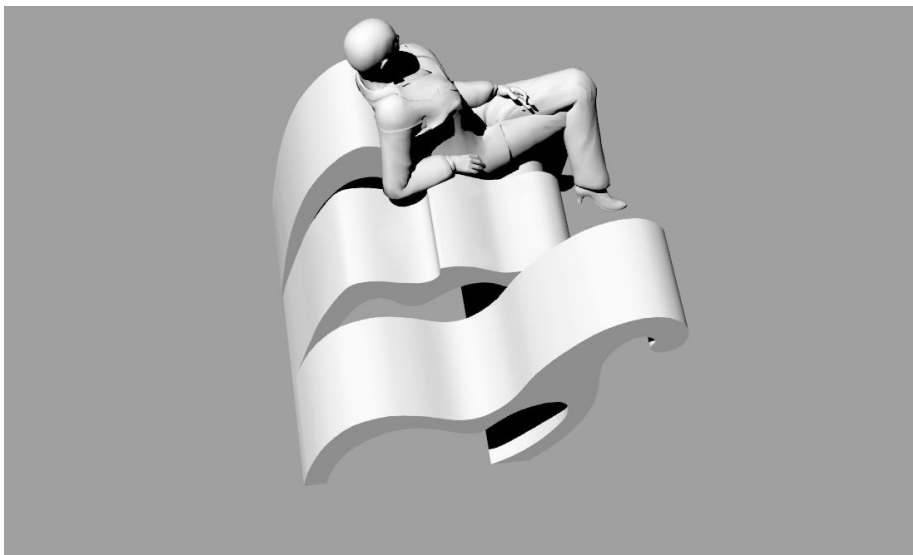
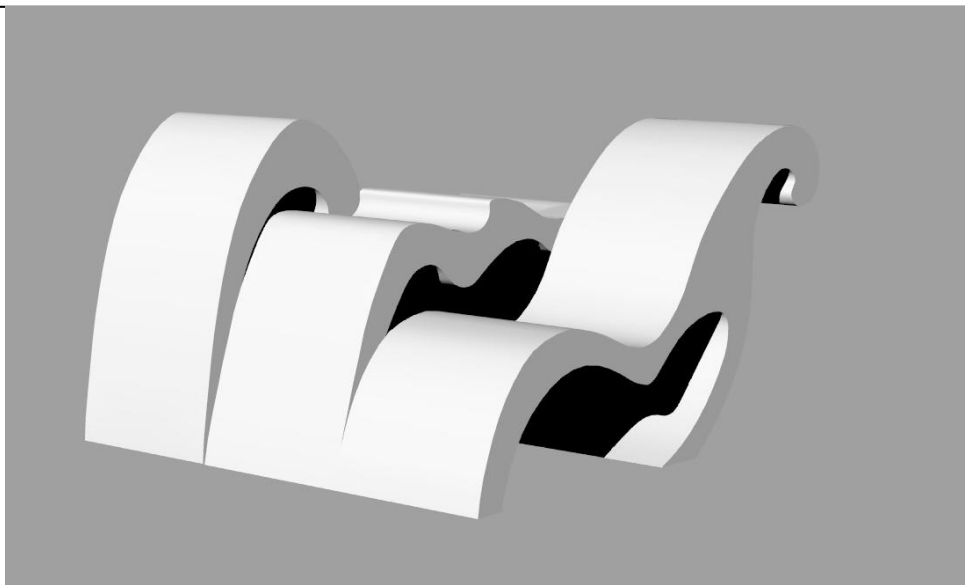

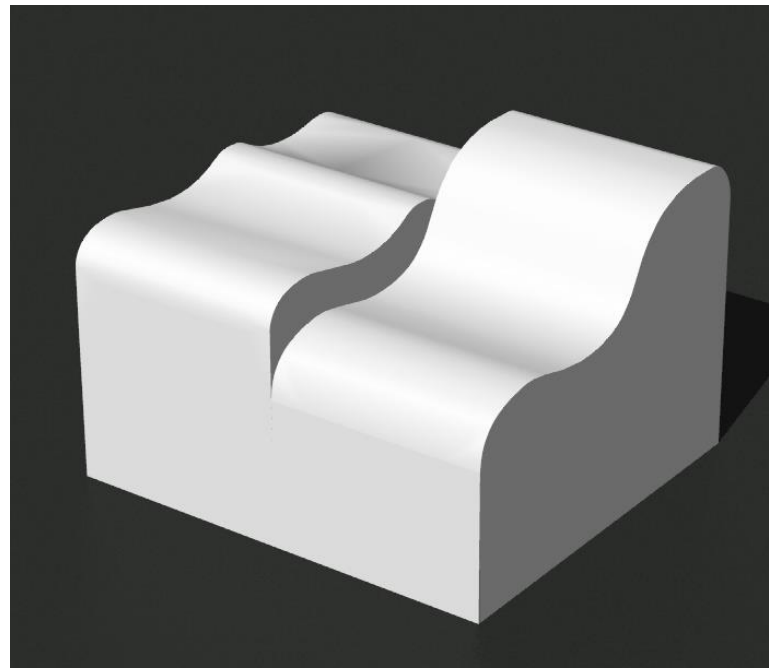
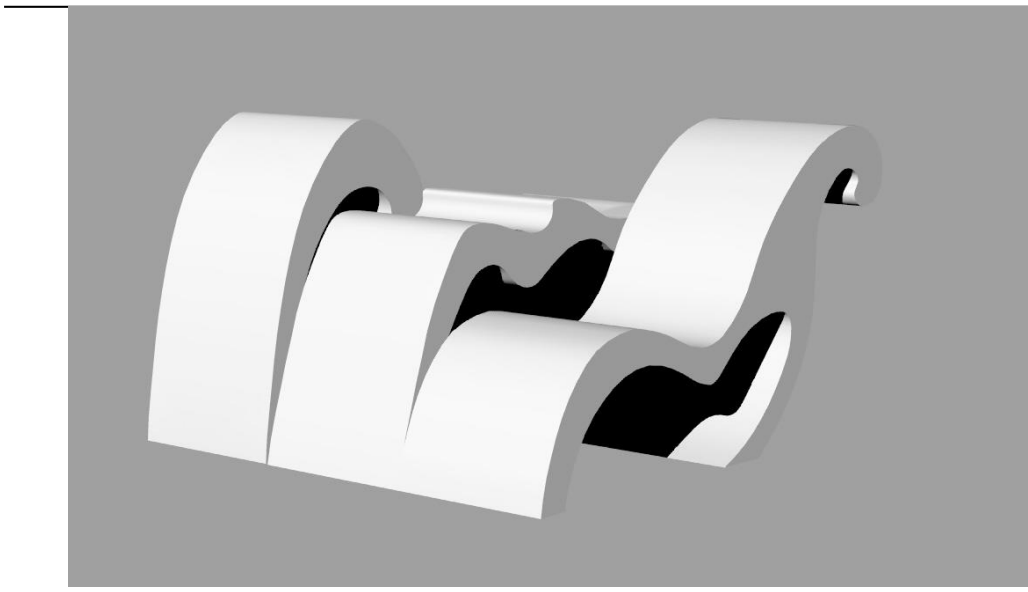

**Negative and positive spaces.**

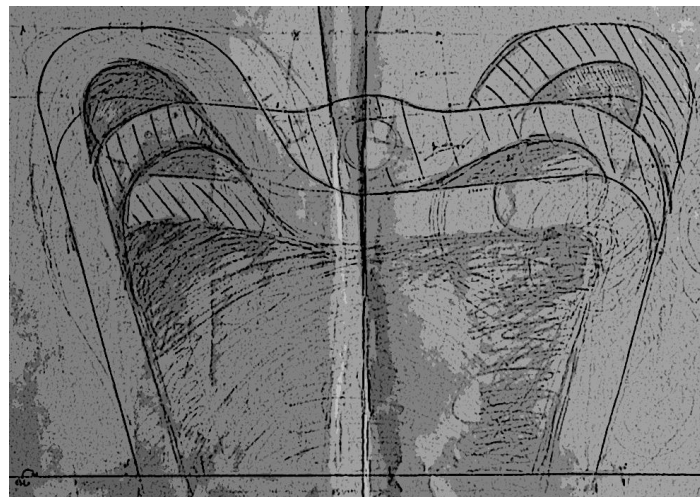
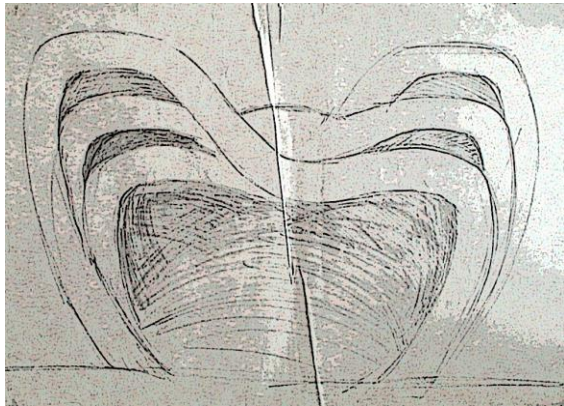
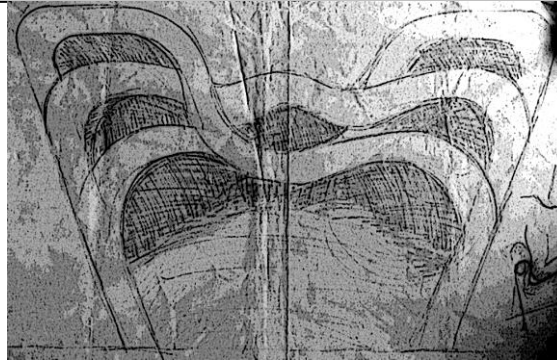
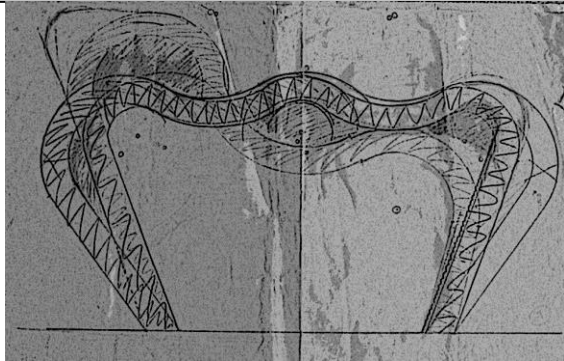

# Effect of material on form

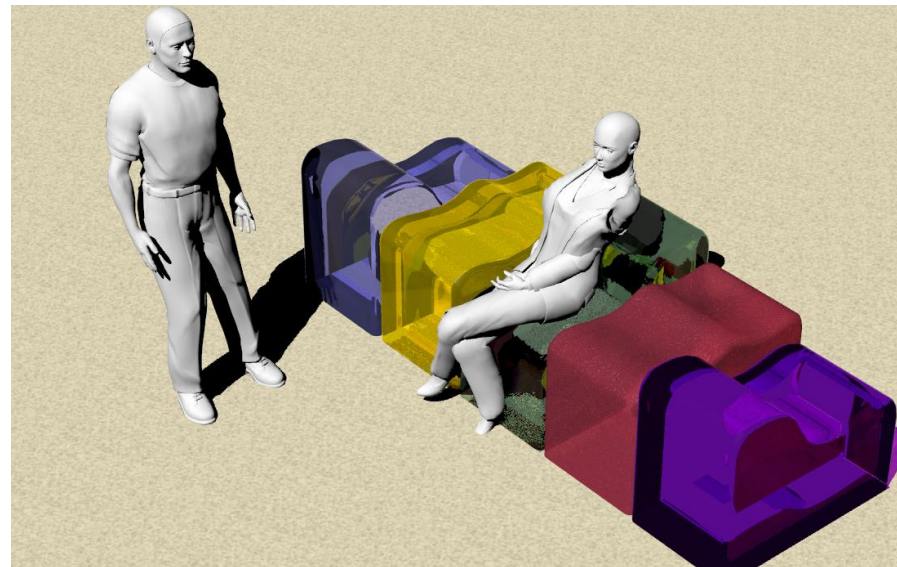
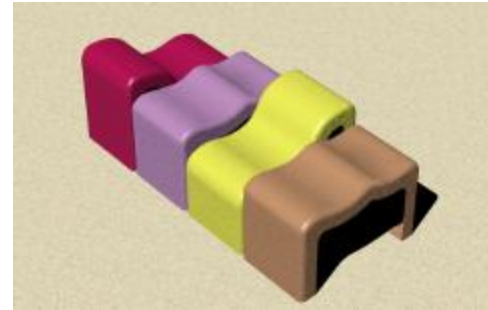

Tranlucent  
Play of light  
Variation in colour  
Merging of colours

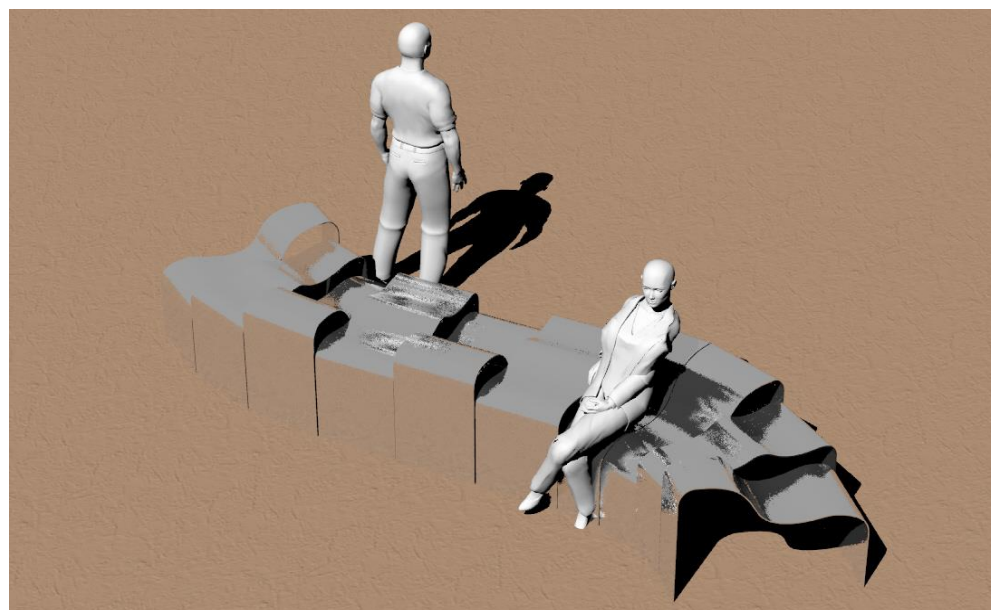
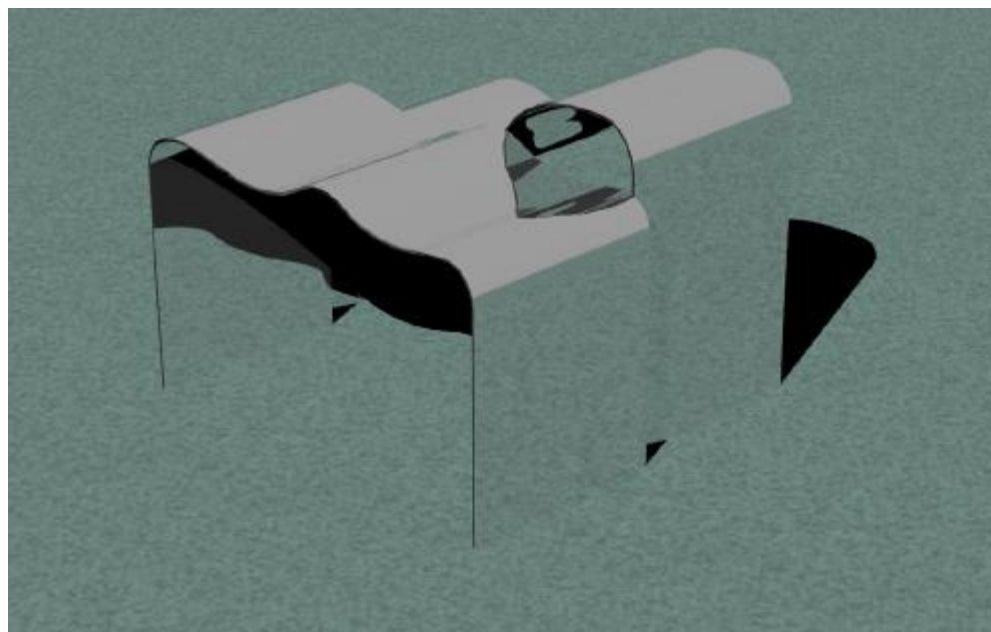

Reflection

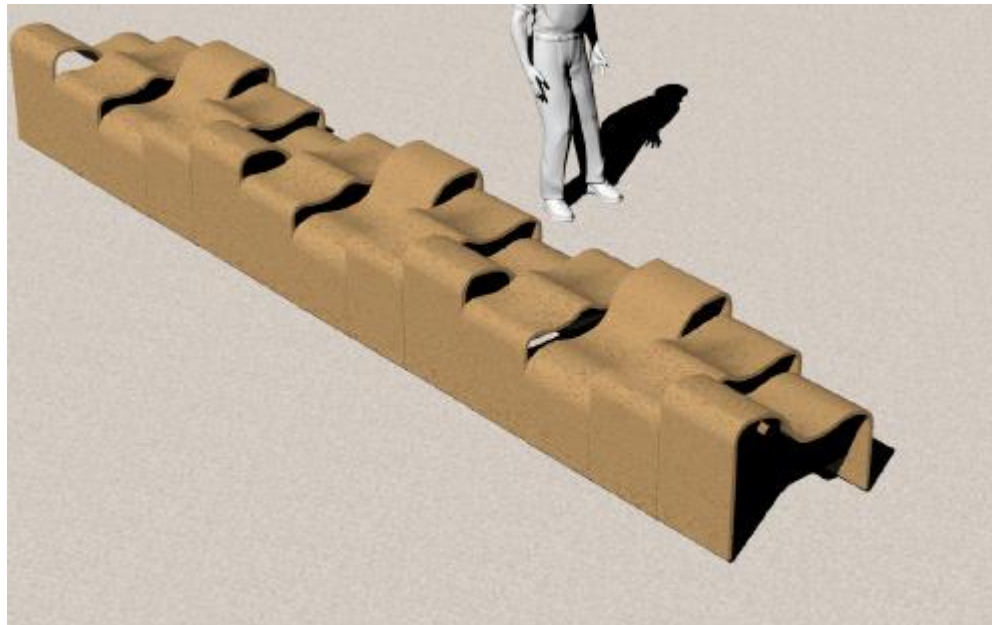
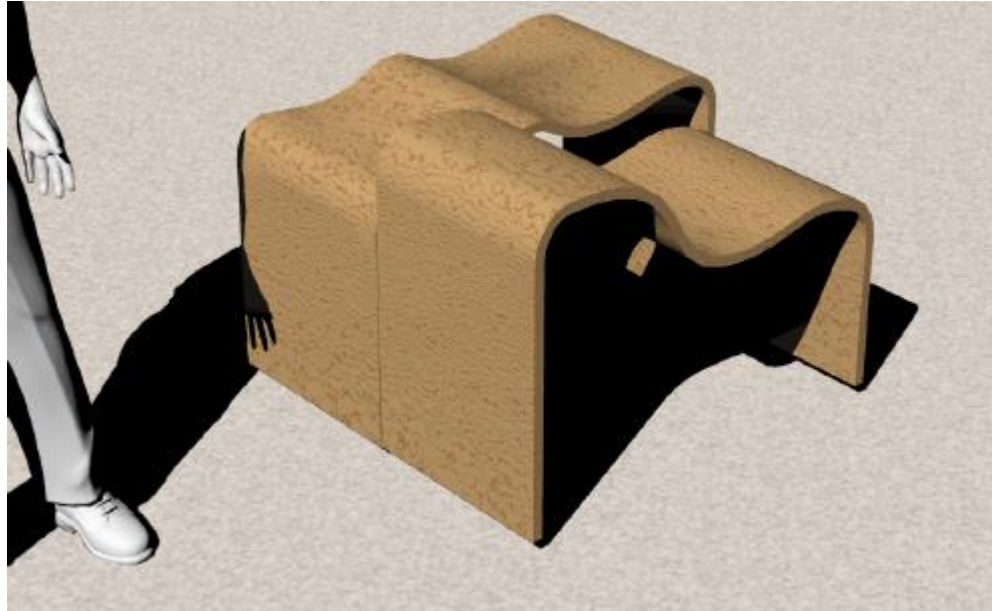

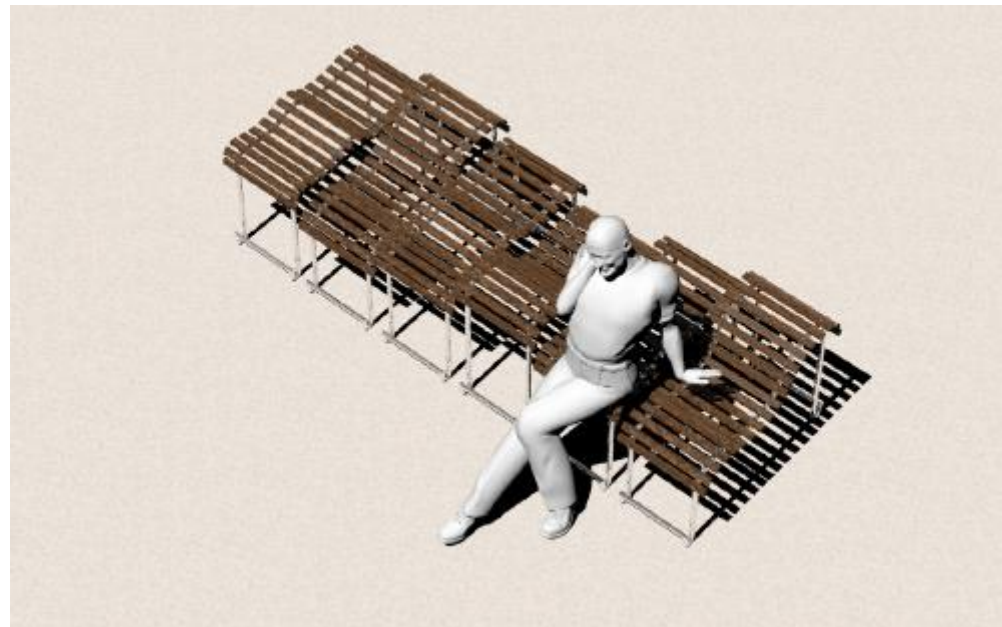

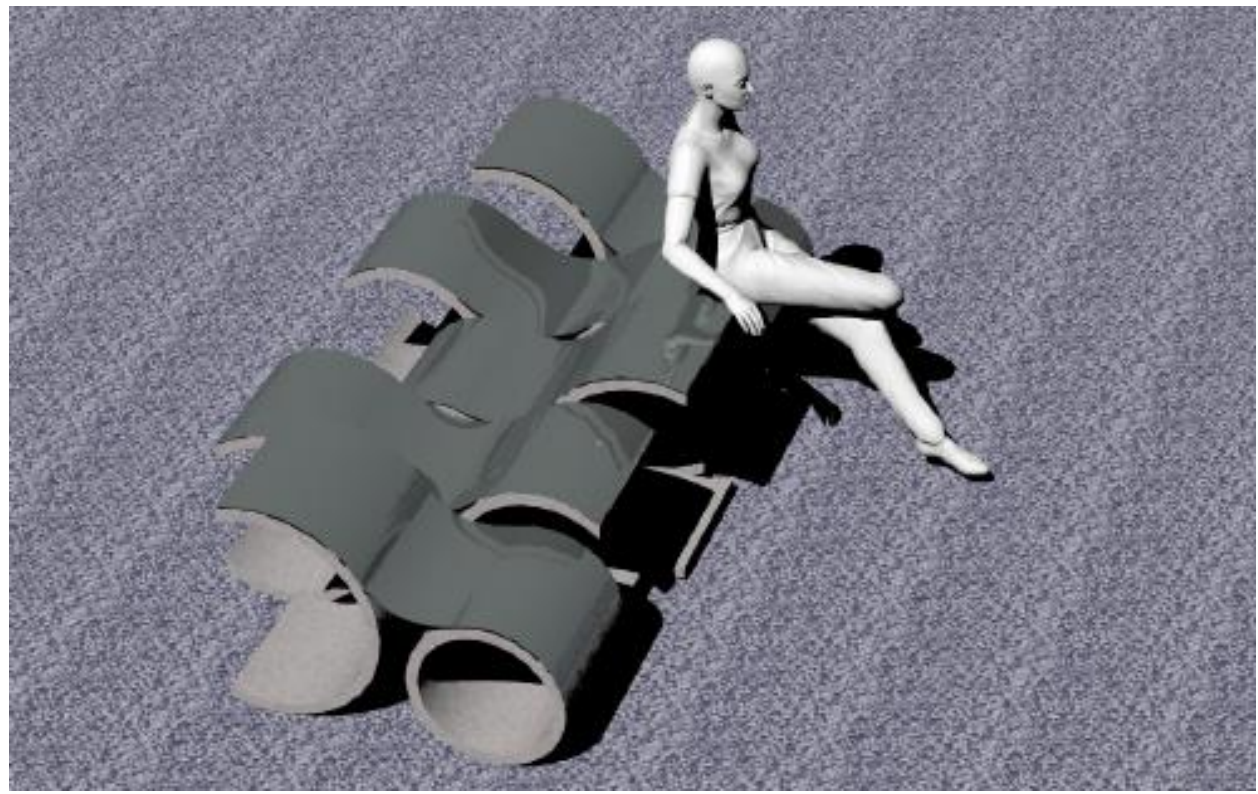
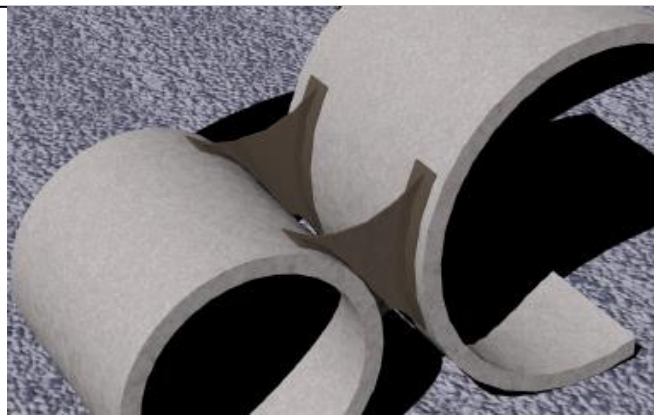
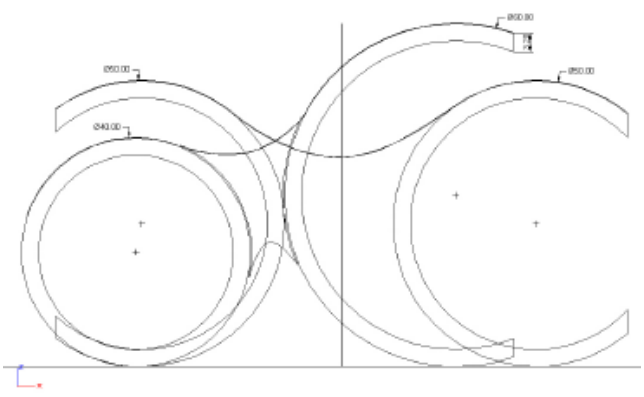

Material Exploration

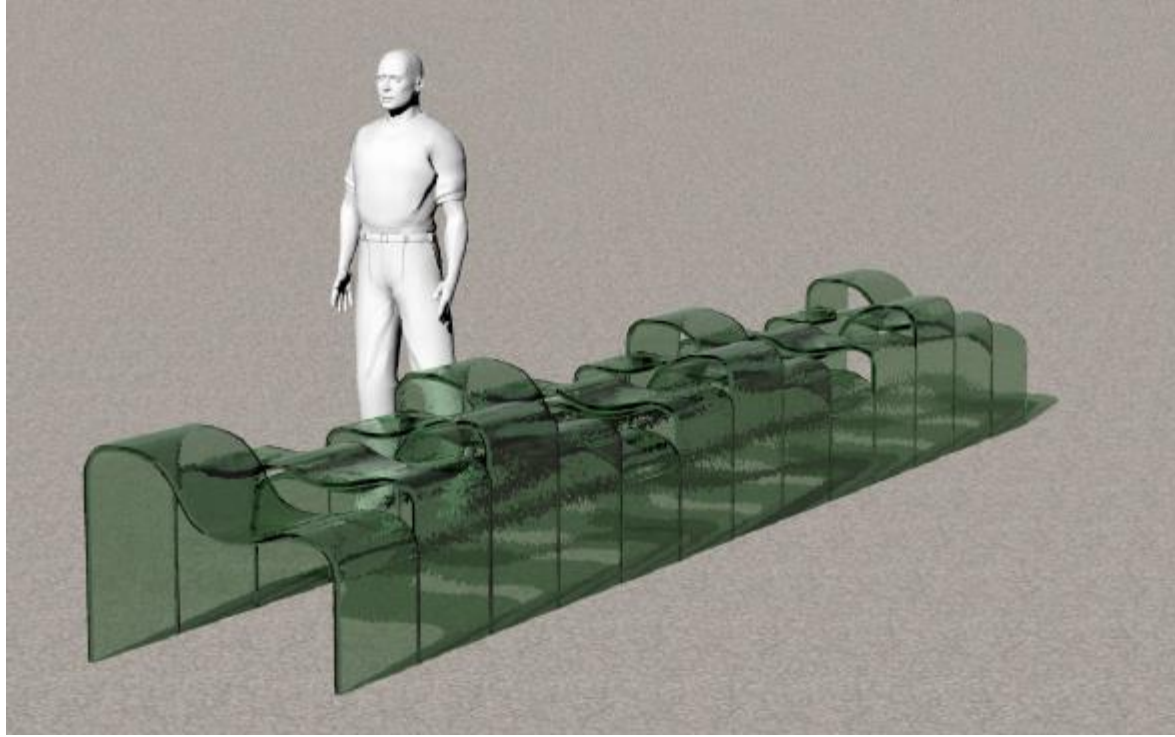
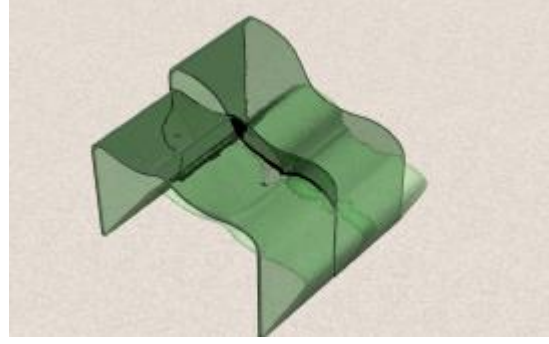
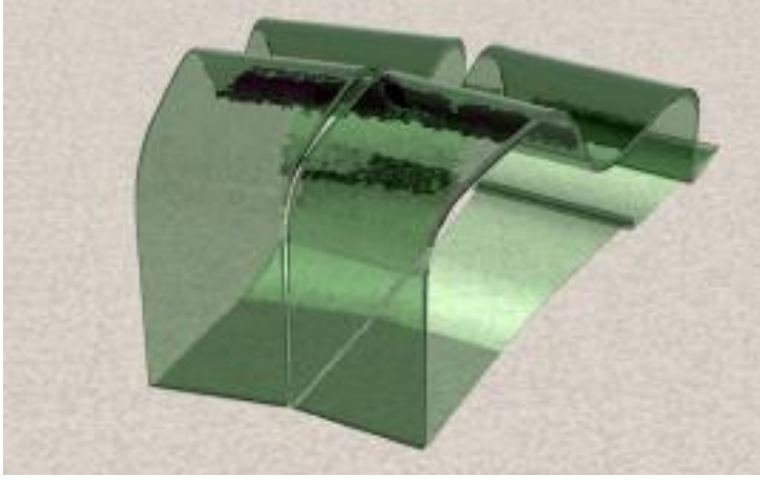

Material Exploration

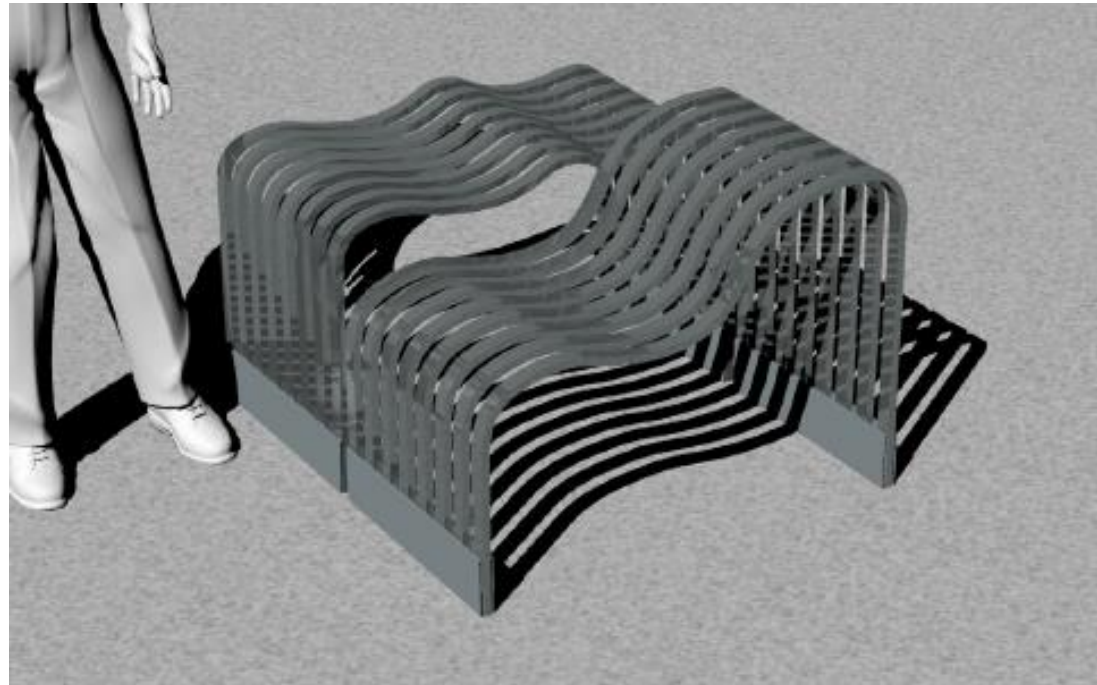
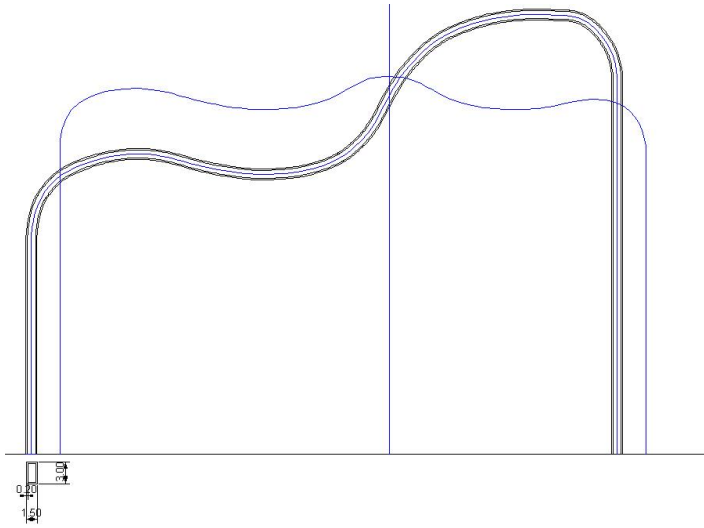

Looks light, the sections along the curve supplement the form. The parallel tubes also creates interesting shadow patterns

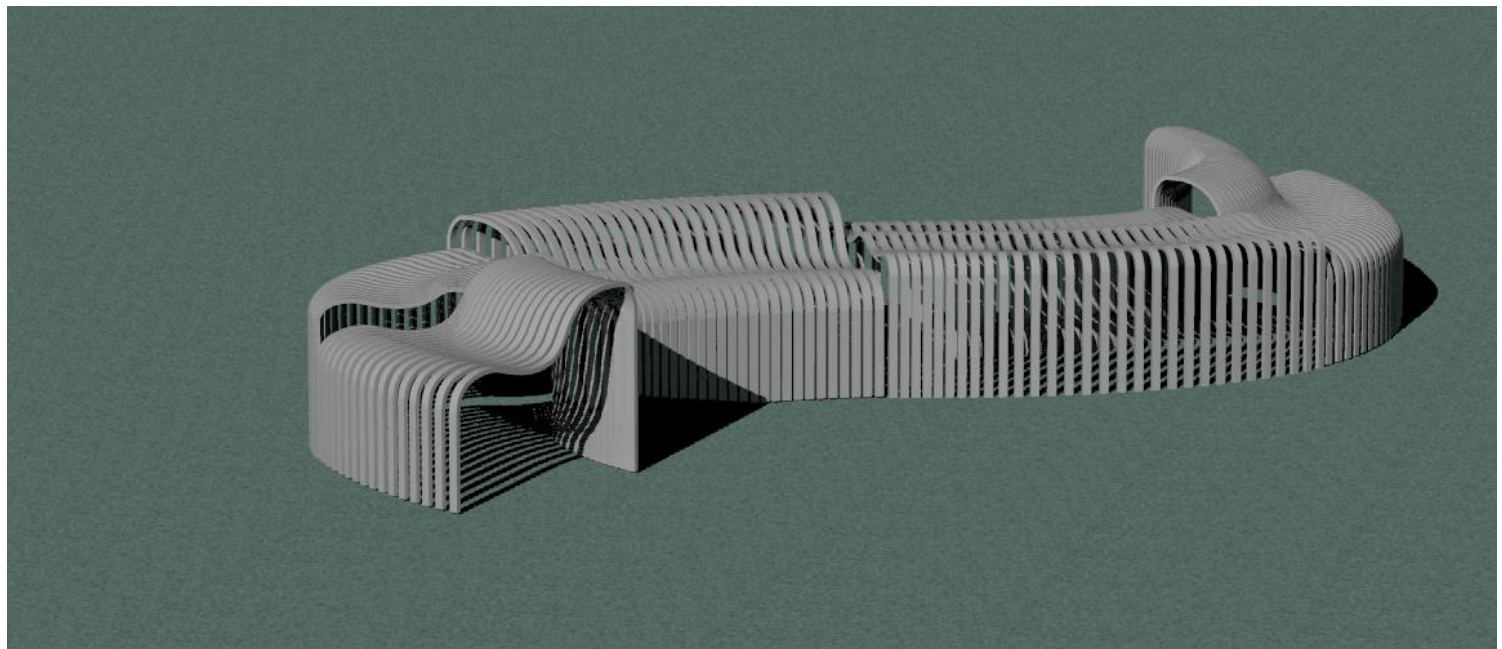
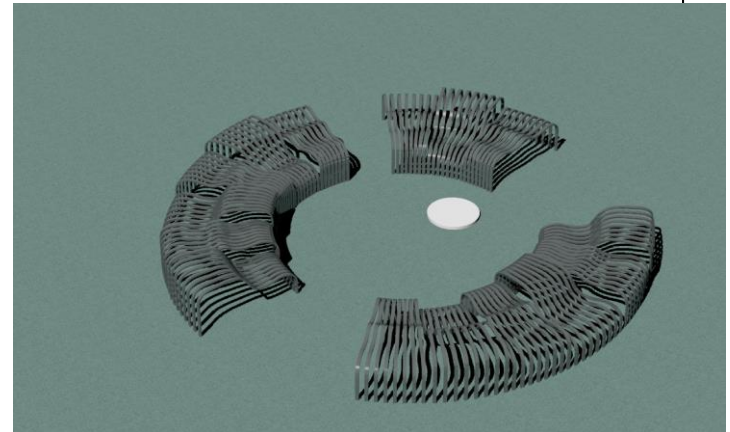

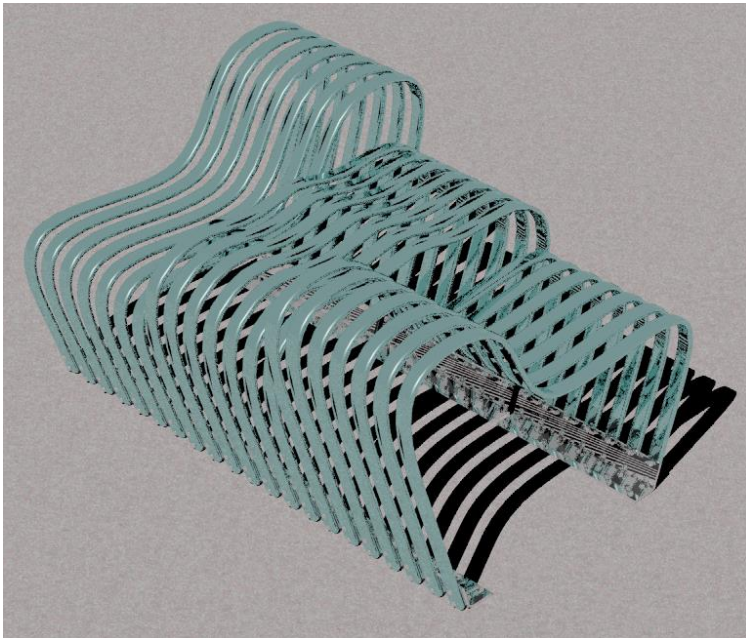

***Each module complete in itself.***

***The interplay of presence and absence of elements.***

***Emerging from the ground.***

***The form as a structure is strong. But the elements constituting (the curves, the sections the gaps and the detailing at the end the structure of the form makes it look light.***

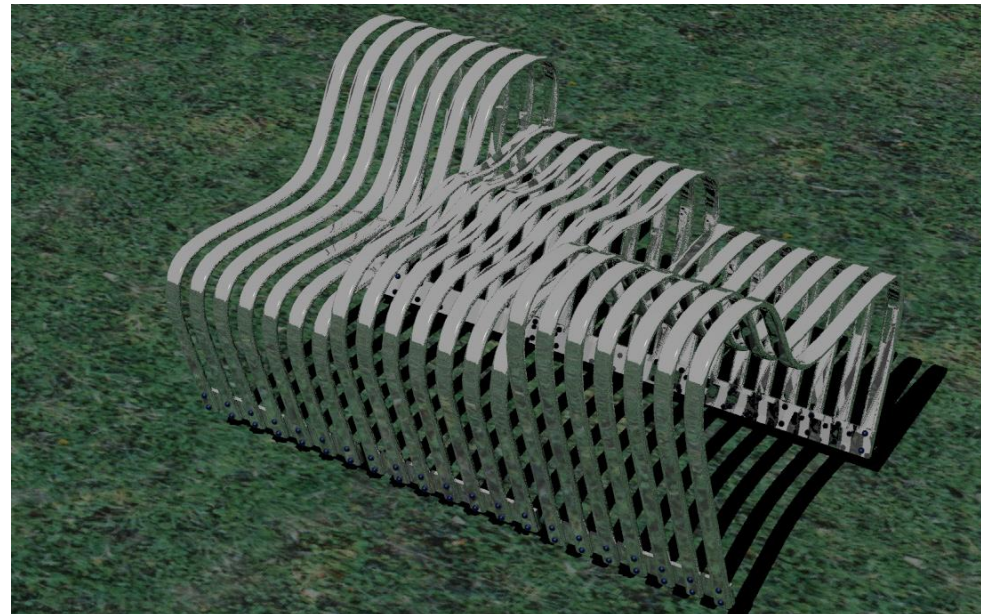



Architects, landscape architects, interior designers or urban designers may incorporate the design into their own design process by configuring the modular product to suit their environment. For architects who want to design objects for the space that they create.

This bench would be appropriate for designers who appreciate assistive products that enhance their creation of beautiful spaces, but do not have the facility to manufacture custom made ones.

The product will compete with other public seating and provide an alternative to expensive custom-made furniture.



**Thank You**