

Air Transportation System

Modular Aerial Vehicle

Guide: Prof. P Kumaresan

Minu (176130011)

Modular Vehicle

A modular vehicle is one in which substantial components of the vehicle are interchangeable. This modularity is intended to make repairs and maintenance easier, or to allow the vehicle to be reconfigured to suit different functions.

In a modular electric vehicle, the power system, wheels and suspension can be contained in a single module or chassis.

History Of Manned Drone Attempts

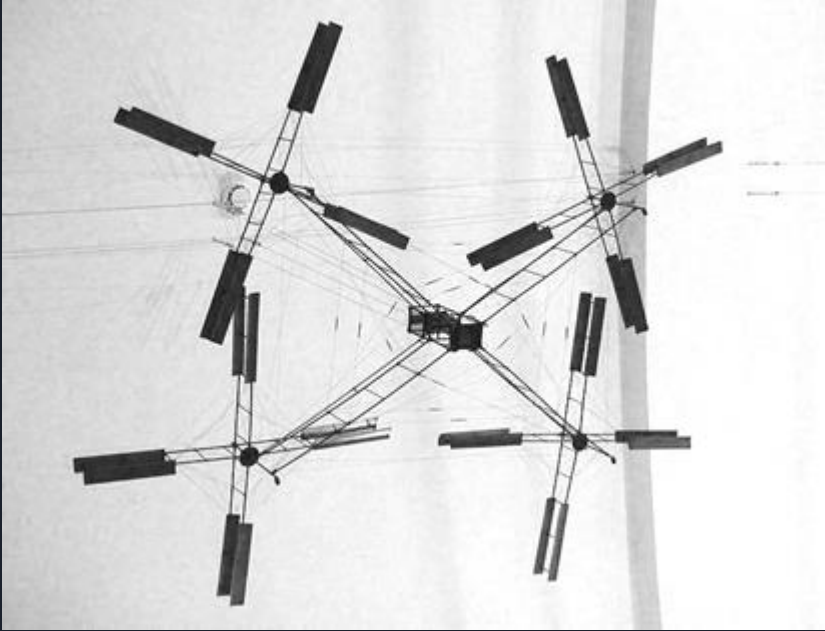

Breguet-Richet Gyroplane No.1, 1907

- The Gyroplane No.1 was flown for the first time, albeit to an elevation of only 0.6 meters.
- It was neither controllable nor steerable, but it was the first time that a rotary-wing device had lifted itself and a pilot into the air.

History Of Manned Drone Attempts



'Oehmichen No.2, November 1922



de Bothezat helicopter Dec 1922

- An improved helicopter featuring small vertically mounted rotors which rotated in the opposite direction from the large lifting rotors, probably creating the first reliable flying helicopter capable of carrying a person. This work later led to the development of the tail rotor.
- Although its four massive six-bladed rotors allowed the craft to successfully fly, it suffered from complexity, control difficulties, and high pilot workload, and was reportedly only capable of forward flight in a favorable wind.

History Of Manned Drone Attempts



Convertawings Model A, 1956



Curtiss Wright VZ-7. 1958

- It was the first to use propulsion, or a propeller's forward thrust, to control an aircraft's roll, pitch and yaw.
- The craft was capable of hovering and forward flight and proved relatively stable and easy to operate but was consistently incapable of meeting the altitude and speed requirements specified by the Army.

How Do Helicopters Fly?

Helicopters make air move over airfoils to generate lift, but instead of having their airfoils in a single fixed wing, they have them built into their rotor blades, which spin around at high speed. The rotors are like thin wings, "running" on the spot, generating a massive downdraft of air that blows the helicopter upward. With skillful piloting, a helicopter can take off or land vertically, hover or spin on the spot.

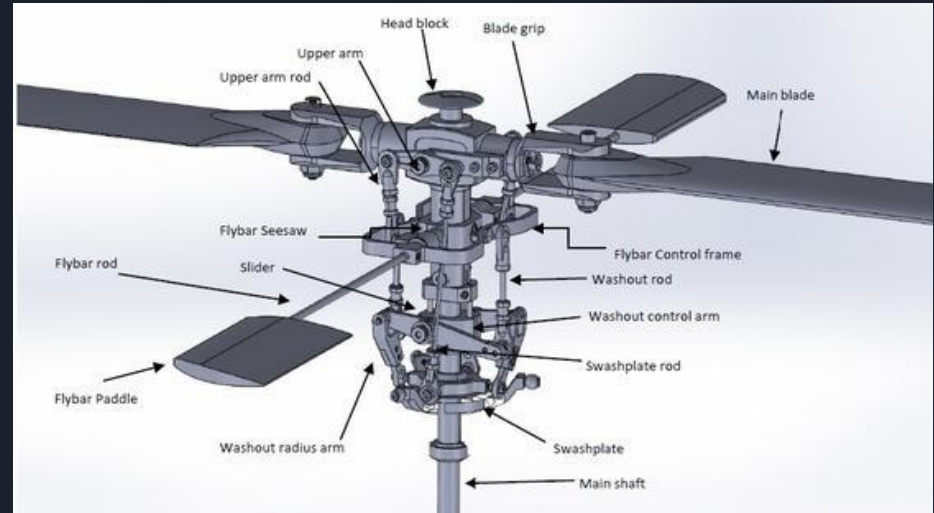

Helicopter Rotor Mechanism description

How Do Helicopters Fly?

As a helicopter rotor spins around, the entire body of the craft tends to rotate slowly in the opposite direction. This can be controlled in two ways, one solution is to have a second large rotor spinning the other way. another way to counteract the torque from the main rotor is by using a small, sideways-pointing propeller called a tail rotor.



This military Boeing CH-47 Chinook has one rotor at the front and one at the back and they spin in opposite directions to cancel one another's torque.

How do Drones fly?

Each rotor produces both a thrust and torque about its center of rotation, as well as a drag force opposite to the vehicle's direction of flight. In this configuration, the rotors 2 and 4 are rotating counterclockwise and the rotos 1 and 3 are rotating clockwise. With the two sets of rotors rotating in opposite directions, the total angular momentum is zero. Thus, if there is no torque on the system (the system here being the drone), then the total angular momentum must remain constant (zero in this case).

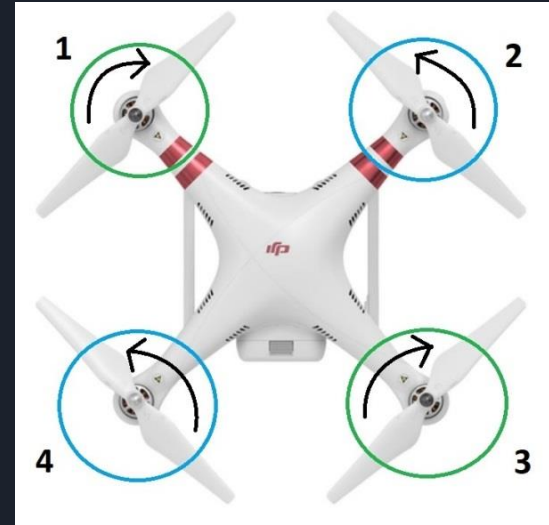

Rotational directions on quadcopters

Tilt Rotors

Tilt rotor propellers drag the plane forward.

In vertical flight, the tiltrotor uses controls in following manner;

- Yaw is controlled by tilting its rotors in opposite directions.
- Roll is provided through differential power or thrust.
- Pitch is provided through rotor cyclic or nacelle tilt.



The Bell Boeing V-22 Osprey tilt rotor

Why Passenger Drone?

Quadcopters are more stable (fitted with electronic stabilization)

Quadcopter's simple design wins over many pilots. They do not come with long shafts, unlike helicopters. These are difficult to align.

Controls are better and easy – lesser the controls - making AI will be easier compared to flight mechanics; Variables will be lesser to automation easier, software faster and more accurate.



workhorse group's personal passenger drone

Design Brief

Design statement: Developing a modular aerial platform for multipurpose use.

Problems to be addressed:

Solving congestion and on-demand mobility problem by utilizing 'Urban Airspace'
Designing modular vehicle with standardized chassis that can accommodate different body types.

Design targets:

Chassis for various body types.

Basic interior layout.

Light weight body

Target Audience

Targeted audience are the logistic/taxi company

Parallel Products

At least 20 companies are developing aerial taxi plans including

- Workhorse - *Surefly*
- Ehang - *Ehang 184, Ehang 216*
- Uber Air
- Boeing
- Airbus – *Airbus CityAirbus, A³ Vahana, Pop Up*
- Bell Helicopters
- Lazzarini's hover coupe – flying car concept



Bell- Nexus



Workhorse - Surefly



Airbus Pop Up



Ehang 184



Lazzarini's hover coupe



Airbus CityAirbus

Initial Sketches

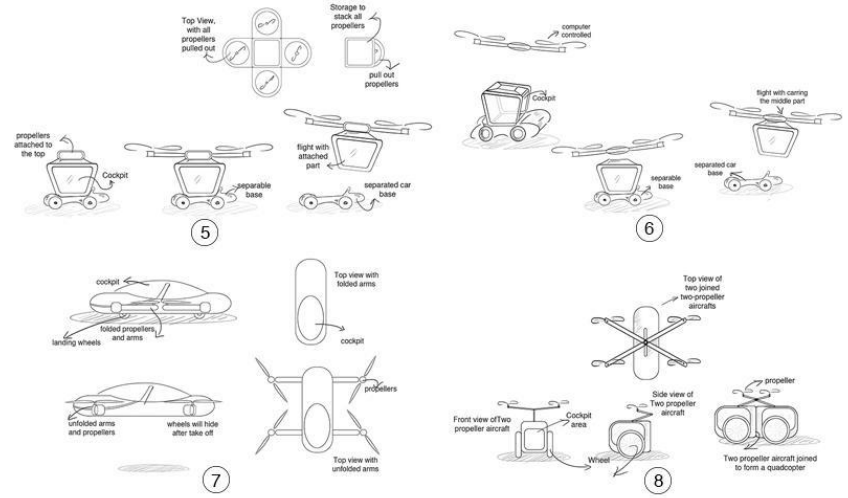
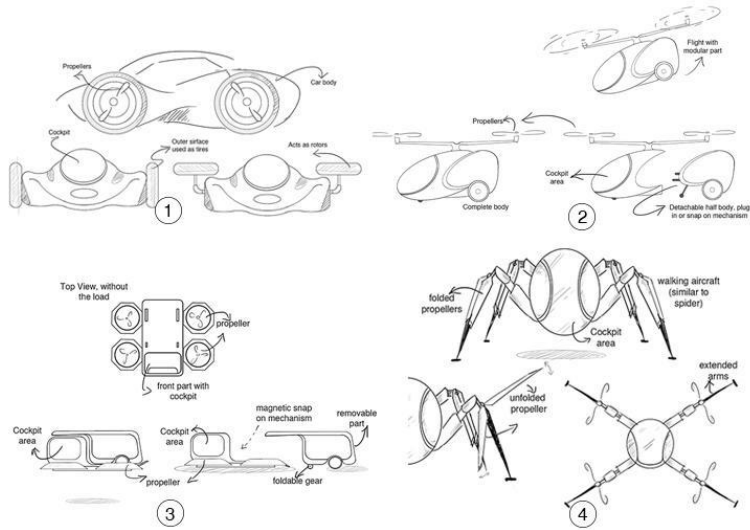

Paper models

Model 1



Model 2



Model 3



Model 4



Model 5



Concepts Development

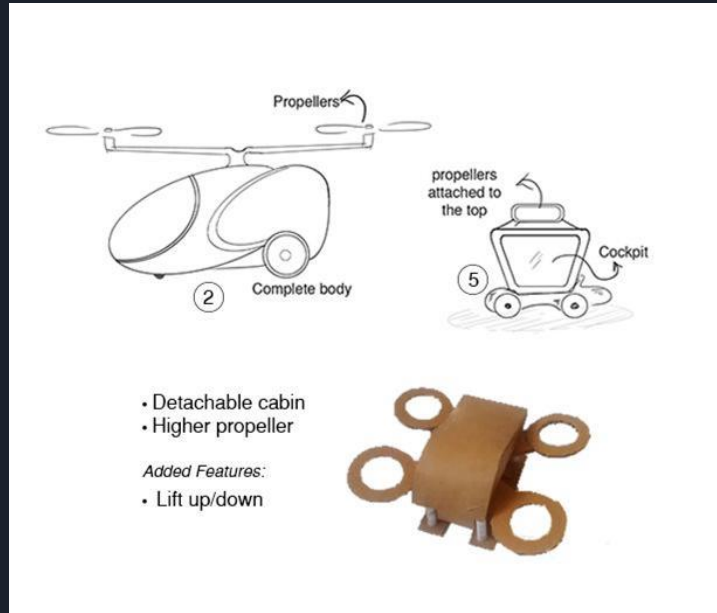

Concept 1

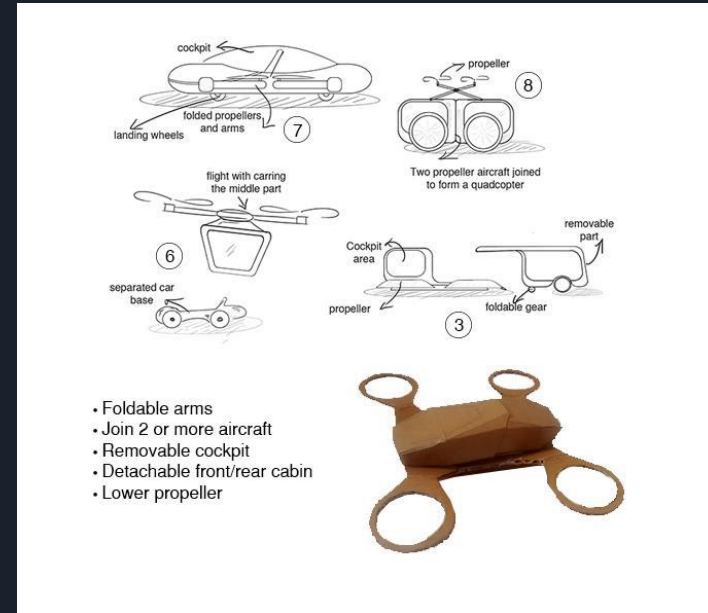

Concept 2

Concept Evaluation

Categories	Concept 1	Concept 2
Stability	0	1
CG position	0	1
Modularity (removable parts)	1	2
Ease of assembly	1	1
Foldability	0	1
Safety	1	1
Extendable	0	1

Final Concept

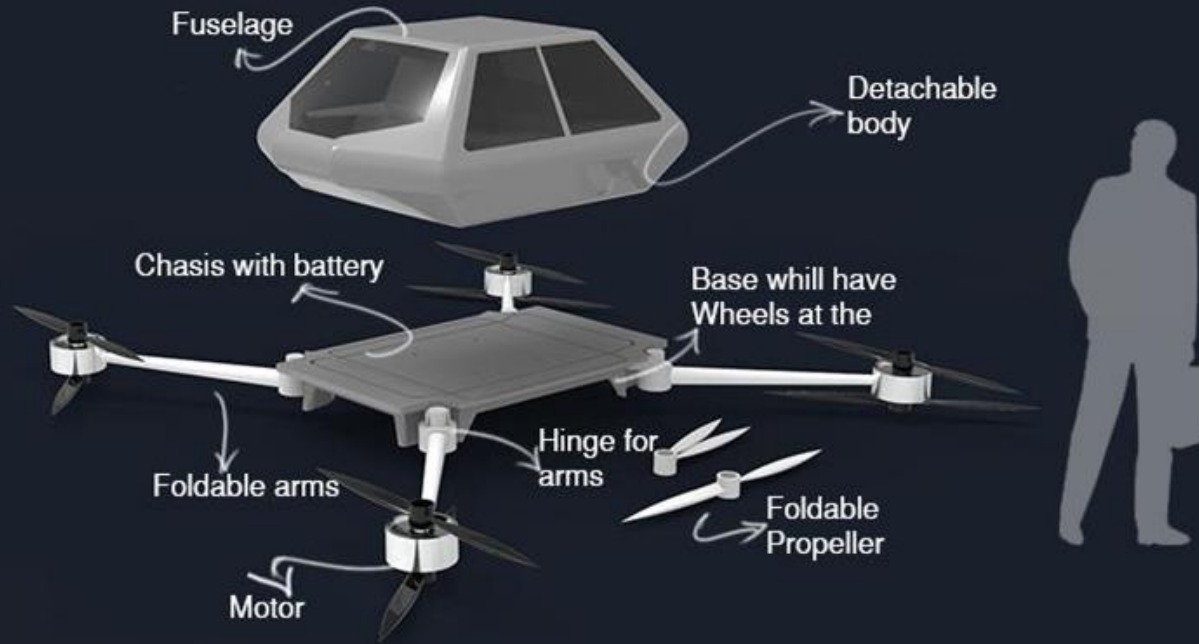

The main components of the Concept

Skateboard Chassis Design

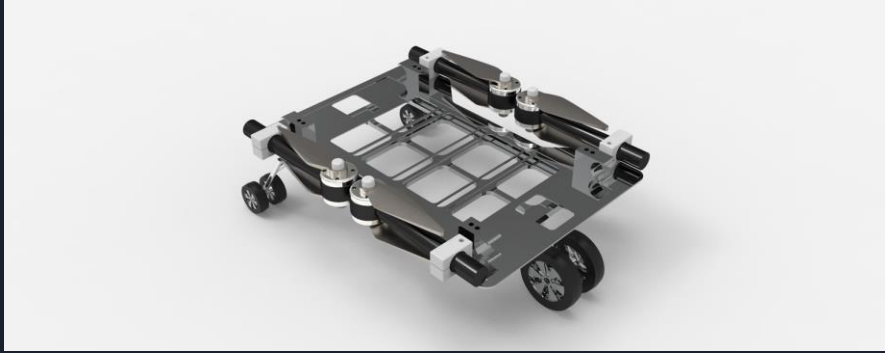

Chassis Design

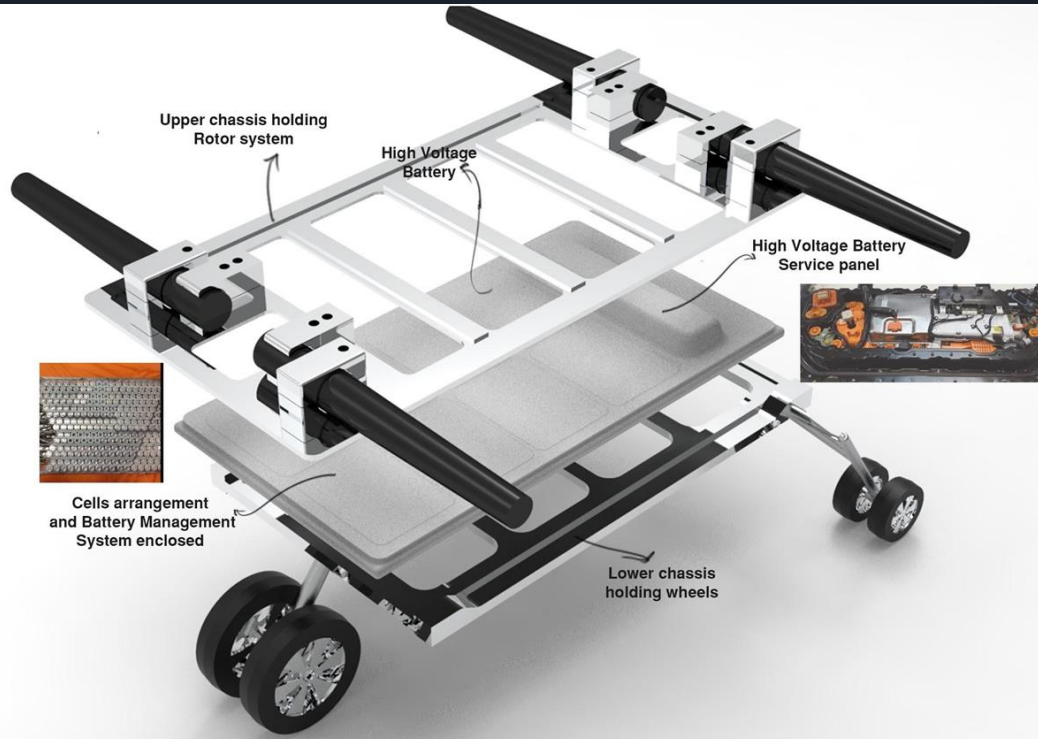

Final Concept

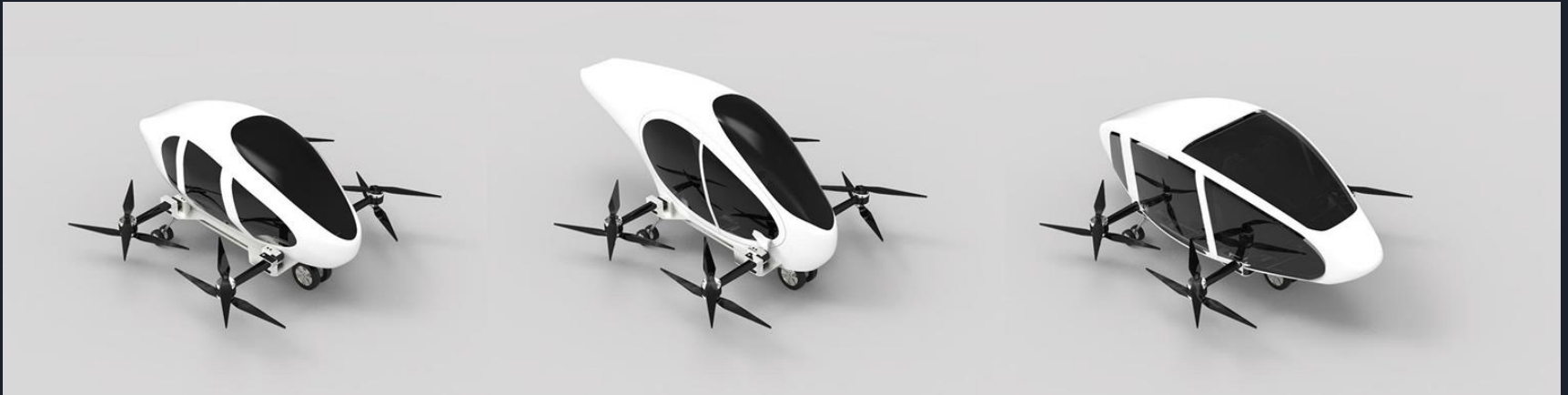

A single chassis can be used for various different form of the fuselage as per the requirement

Specifications

Battery Pack

1 panasonic (18650 type) lithium ion cells (54 grams single unit)

18mm(dia), 65 mm (height), 4Ah capacity, 3.6 volts

1 Brick= 60 cells (parallel)

1 module= 10 bricks (series)

10 modules (series)

6000 Cells

Power: 86.4 kWh

Battery Voltage: 360 V

Battery Weight: 380 kgs

Battery size(with 6000 cells):

2000 mm(L) x 1200 mm(B) x 100mm(H)

Endurance: 15 minutes

Motors Specifications (per motor)

Shaft Diameter:20mm

Motor Dimensions(Dia.*Len):= 150 x 300 mm

Weight (Kg): 25 Kg

Number of motors: 8

Power: 20 hp

Propellers

Number of propellers: 8

Propeller : 30 inch

Maximum Thrust - 200Kg at 4500 RPM per motor

Weight

Passenger: 400 kg

Battery :300 kg

Body: 500 kg

Dimensions

Fuselage

Height: 1626 mm

Width: 1912mm

Length: 4780mm

Horizontal Shaft distance: 6118mm

Vertical Shaft distance: 4221mm

Ground Clearance: 382mm

Lights

Head light and Tail lights

Arm Light: 4pcs (2 red-port, 2 green-Starboard)

Charging Port: 1

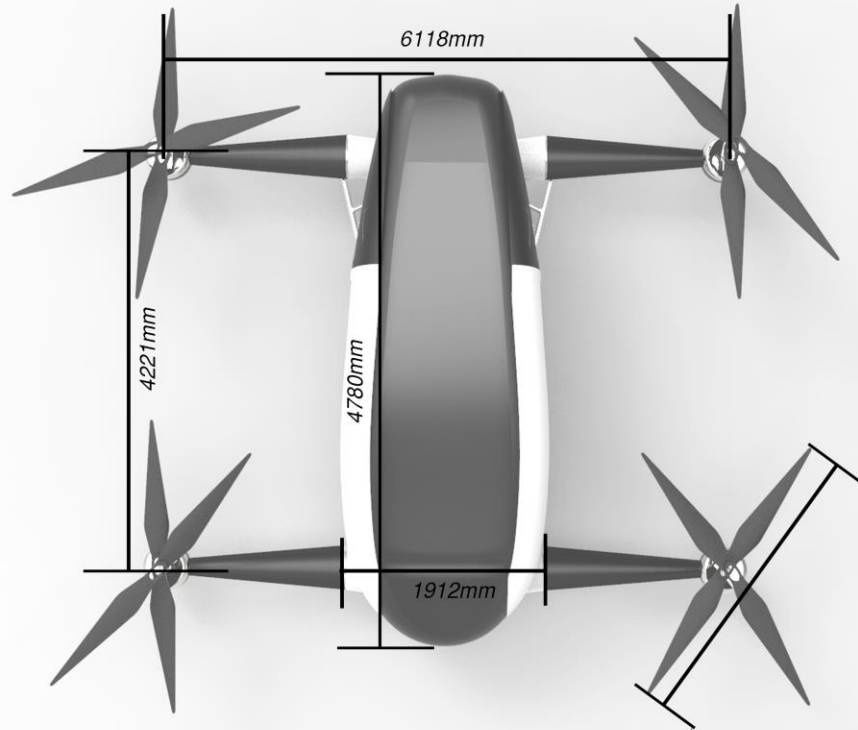

Major Components

The controls are familiar, and are easily recognisable to all pilots and drivers

Major constituents of the vehicle systems

- Flight Controller
- Battery
- Electric Vehicle motor controller
- Steering Wheel
- Motors
- Accelerator
- Brake
- Interior Lights
- Headlight/Tail light
- Arm lights

Interior



The interior has been kept simple and easy and very similar to the automobiles like car, this gives the user a look and feel experience and easier to connect with the interface.

Interface

Image for reference:
self driving vehicle
app

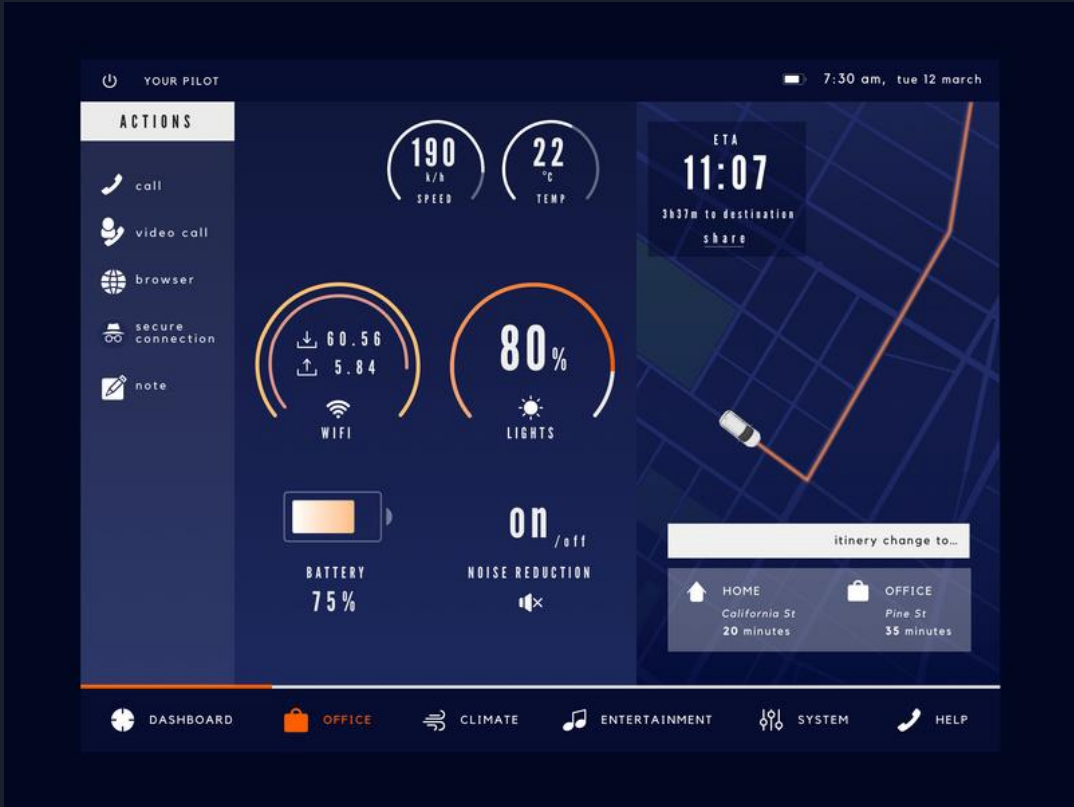

Mechanism

Doors: The final design will be having two doors only rather than four doors. It will have Scissor door open.

Front Easy Entry Seats: Tilt and push the front seat forward to get in easy entry for rear seat passengers.

Folding Arms: The arms holding the motors will be foldable in order to save space while parking or not in flight mode.

Folding Propellers: The propellers will also be foldable in-order to accommodate them under the when arms are folded.

Tilt rotor: Drag the aircraft forward while keeping the aircraft horizontal.



Scissor door



Folding Arms:

Foldable arms

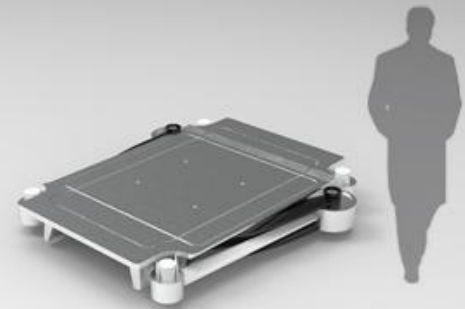
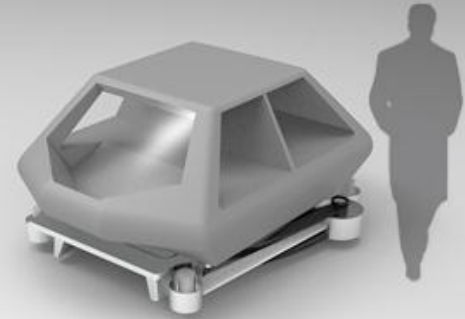

Foldable arms

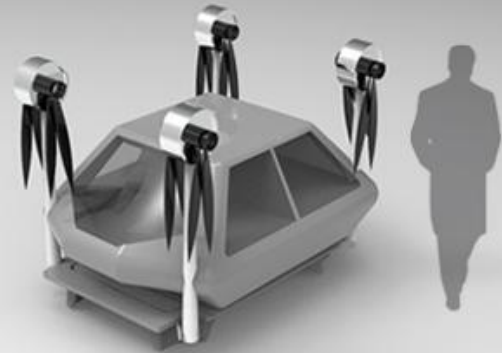
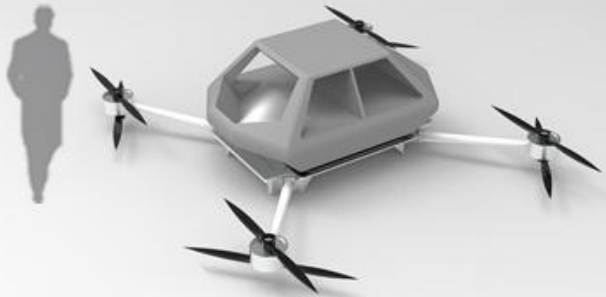

Form Sketches

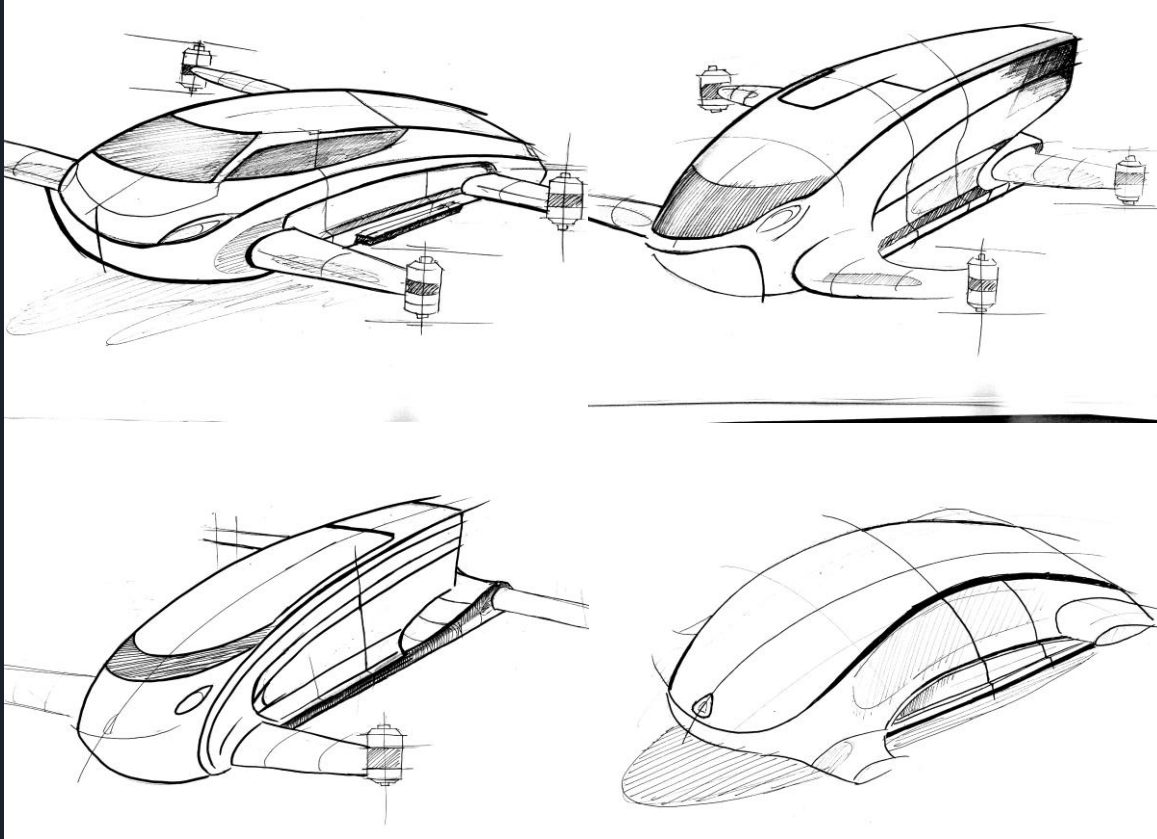

Fuselage Design - Aerodynamic

Streamline flow: flow of a fluid in which its velocity at any point is constant or varies in a regular manner.

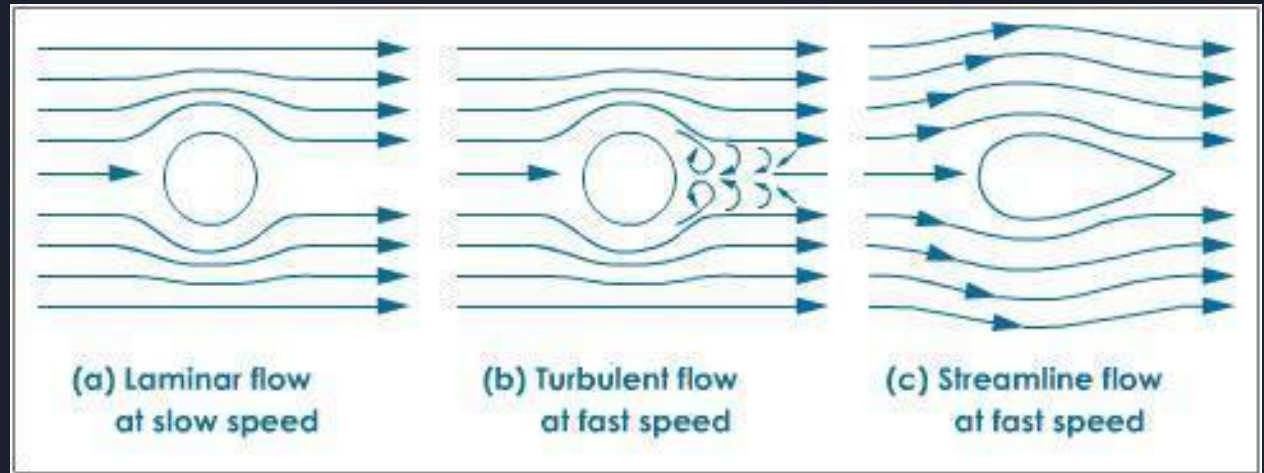

Lights

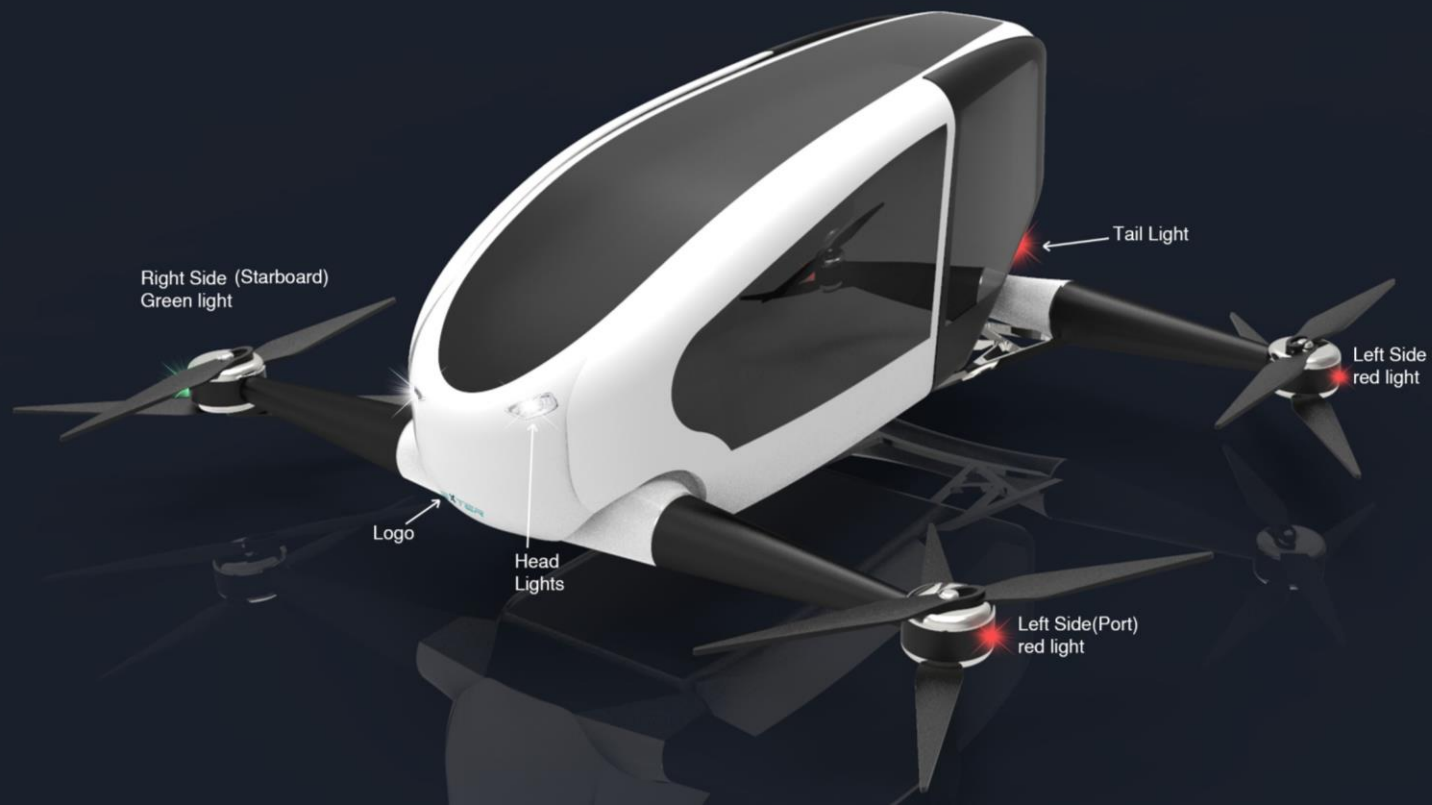

Branding

Name: Vehicle is named as Dexter which means skillful

Logo: 

Significance of Color

White

- Airlines often end up selling their aircraft to other carriers, they will find it harder to do so if the color scheme is anything but white.
- They reflect sunlight and minimises both the heating and any potential damage from solar radiation.
- It makes it easier for any cracks, dents, oil spills and other faults to be identified and repaired swiftly.
- A white plane is easier to spot during search and rescue process.

Modular Design Benefits

- Modular vehicles make it possible to use different types of bodies on one standardized chassis.
- Modular chassis, with its batteries and motor, are relatively easy to work on, since there is no vehicle body to impede access
- Modular design enables quick and easy upgrades (driven by either technology or user improvement),
- The cost of vehicle development can be spread over a wider range of aircraft

Thank you