

DESIGN OF COBBLER TOOLS

BY

PRAVIN S. PADALE

GUIDE :- PROF. U.A. ATHAVANKAR

THE COBBLERS IN PROFESSION

1) THE REPAIR PERSONS



2) MANUFACTURER WITH OWN SHOP



3) THE TRADERS



4) PURE LEATHER CHAPPAL MAKERS.



THE USER PROFILE

The cobblers working in small villages who:

Manufacture only pure leather chappal

Run the business with no employees under them

Use cheapest tools available

Sometimes customize tools for their use



CHAPPALS THAT HE PRODUCES

THE CHAPPAL MAKING PROCESS

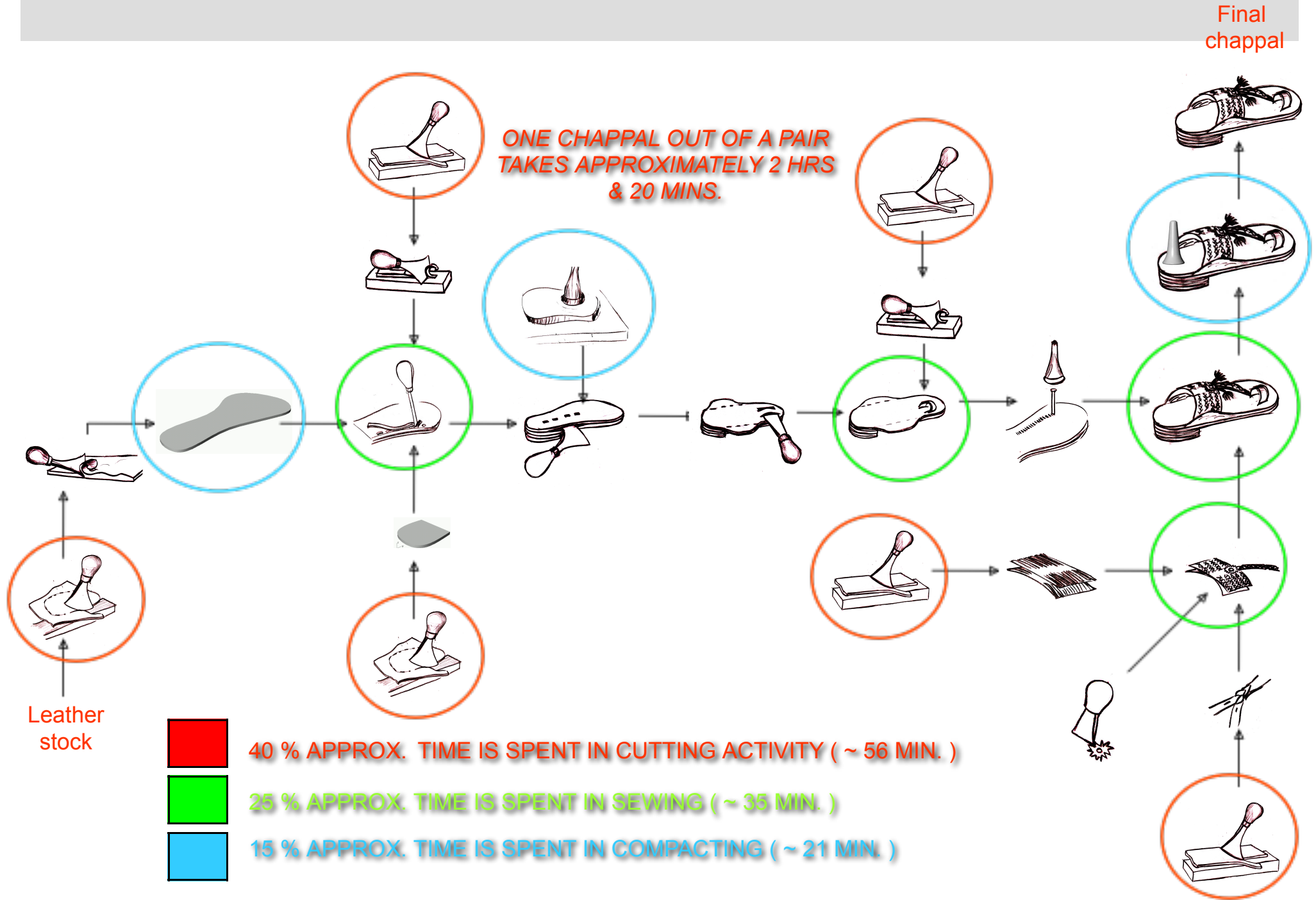

EXISTING LEATHER CUTTING TOOL AND PROBLEMS

EXISTING TOOL

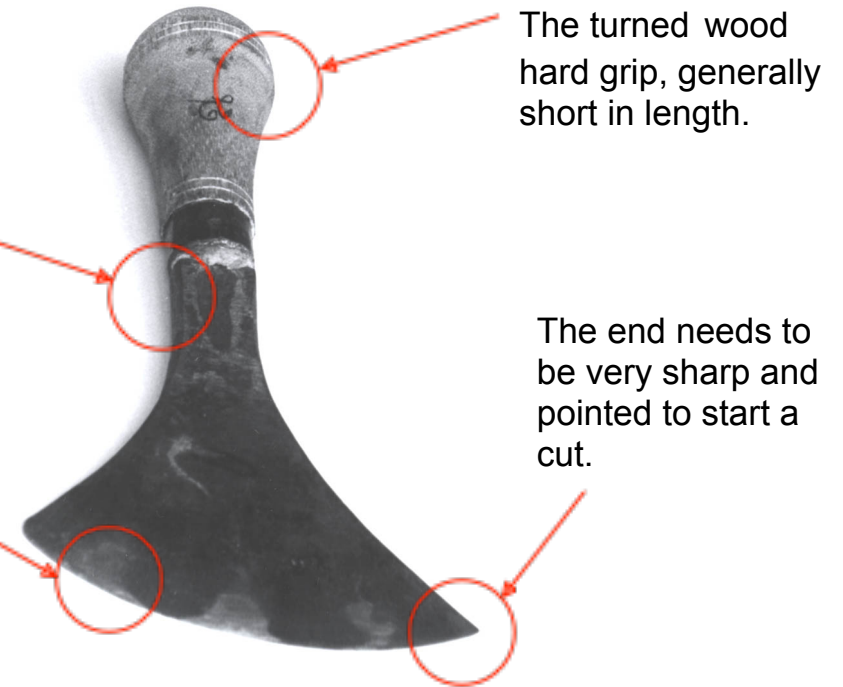

While cutting they hold here.

Hand forged so the curve is not accurate hence there is a lot of difference in wrist movement in every tool

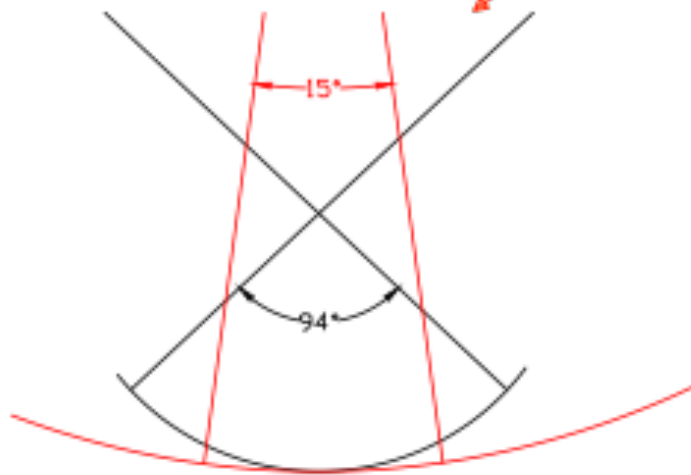

This tool is :-

- Made from forged spring steel
- Available in local market for Rs 25 to 50



This tool acts as a shear with its pivot at the sharp point which they rock it on wooden base. The whole tool act as a L – type lever, in which the small and of L act as a cutting edge as shown in figure.

As the pivot is free for this L, there needs a considerable amount of downward force to maintain the pivot.

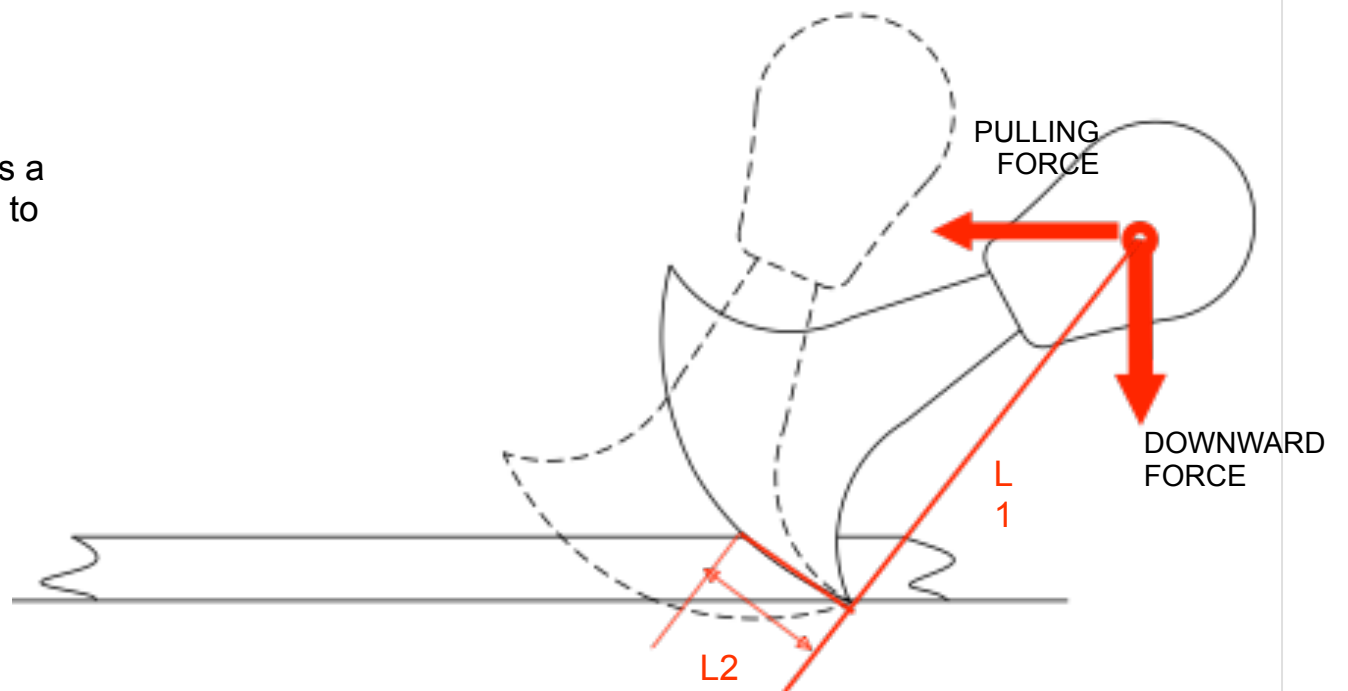

EXISTING SEWING TOOLS AND PROBLEMS

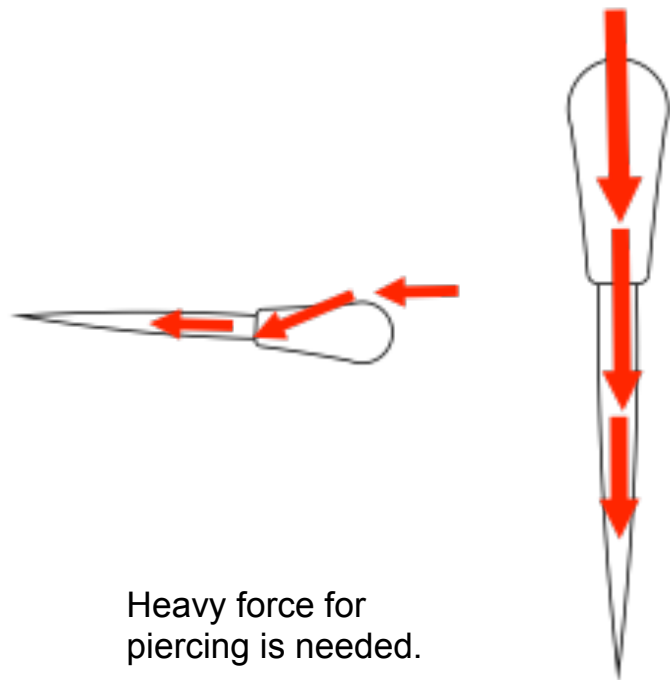

Heavy force for piercing is needed.

The turned wood hard grip, generally short in length.

Pointed edge.

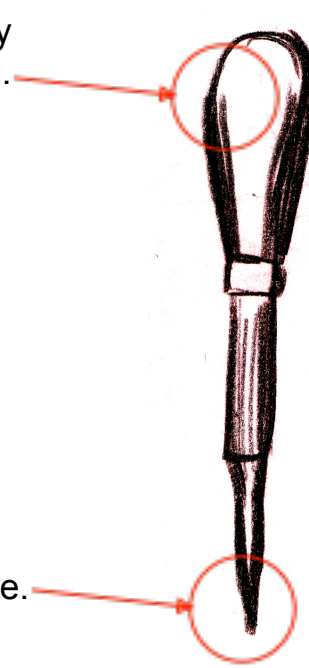

Flat sharp edge.

This tool is :-

- Made from hardened spring steel
- Available in local market for Rs 7 to 25

The stitches that cobblers make are cross wise as shown in the below figure. Due to this the strength of the stitch increases. As explained in below figure, unless the chappal wears till thickness of t , the stitch don't break.

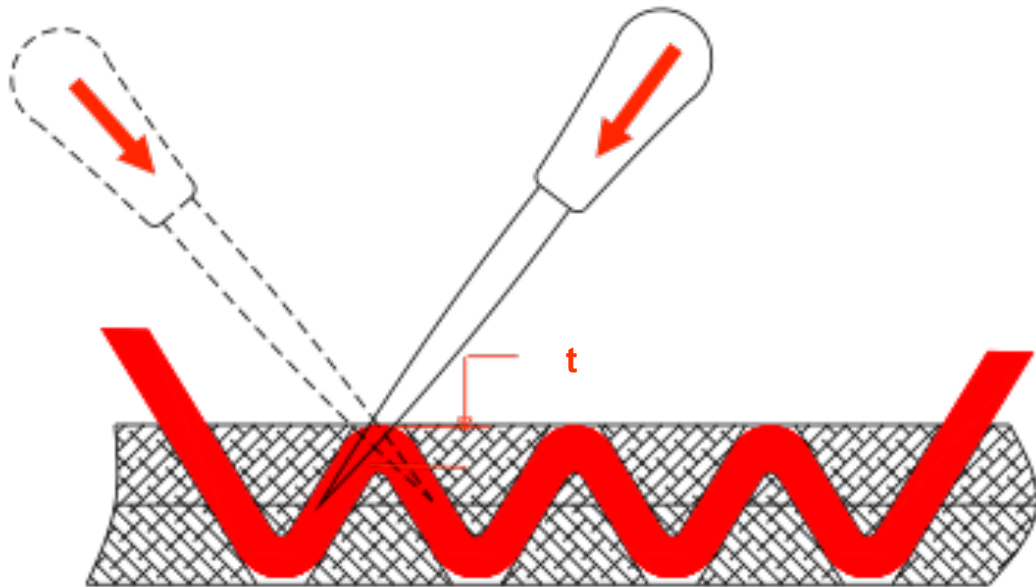
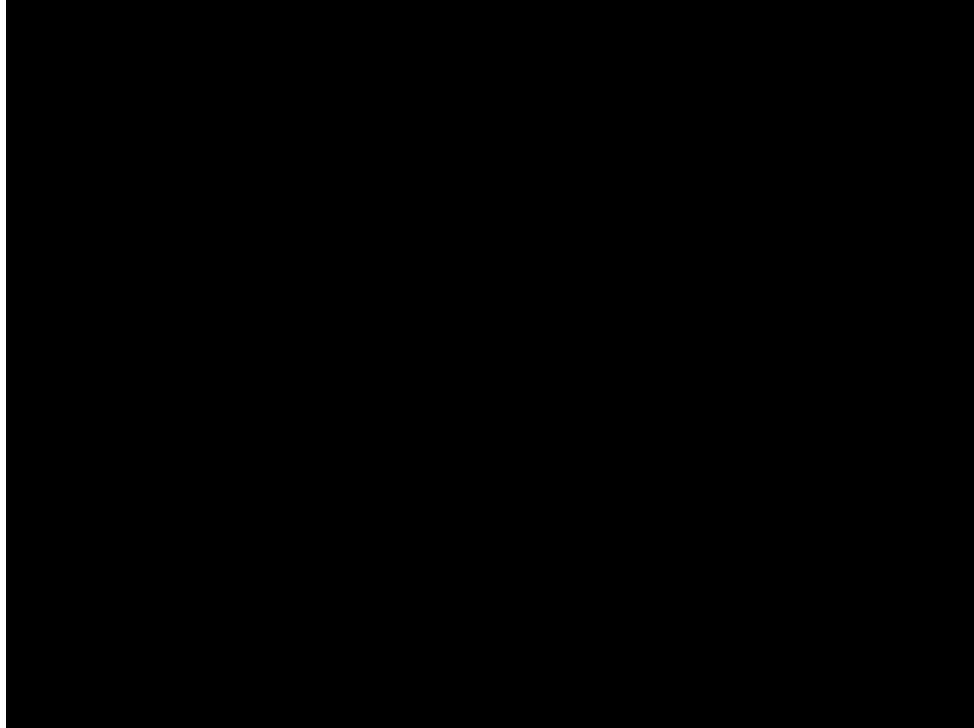

Because of the nature of stitching and thick leather strip, no machine has been ever developed for these chappal makers that they can afford .

THE DESIGN BRIEF

Design the tools for the following processes in chappal making.

- Leather cutting process
- Chappal sewing process

Reasons for selection of processes

- They take almost 70 to 75 % of total time
- They are most exhausting

Cutting Activity

- Accuracy in foot profile cutting.
- Reduced downward force application.
- Fast cutting.

Sewing Activity

- Less application of force on the tool.
- Consistency in the quality of the stitching.
- Reduction in actions.

Ergonomic Requirements

- proper grips
- safety

IDEA GENERATION FOR CUTTING TOOL

Idea 1

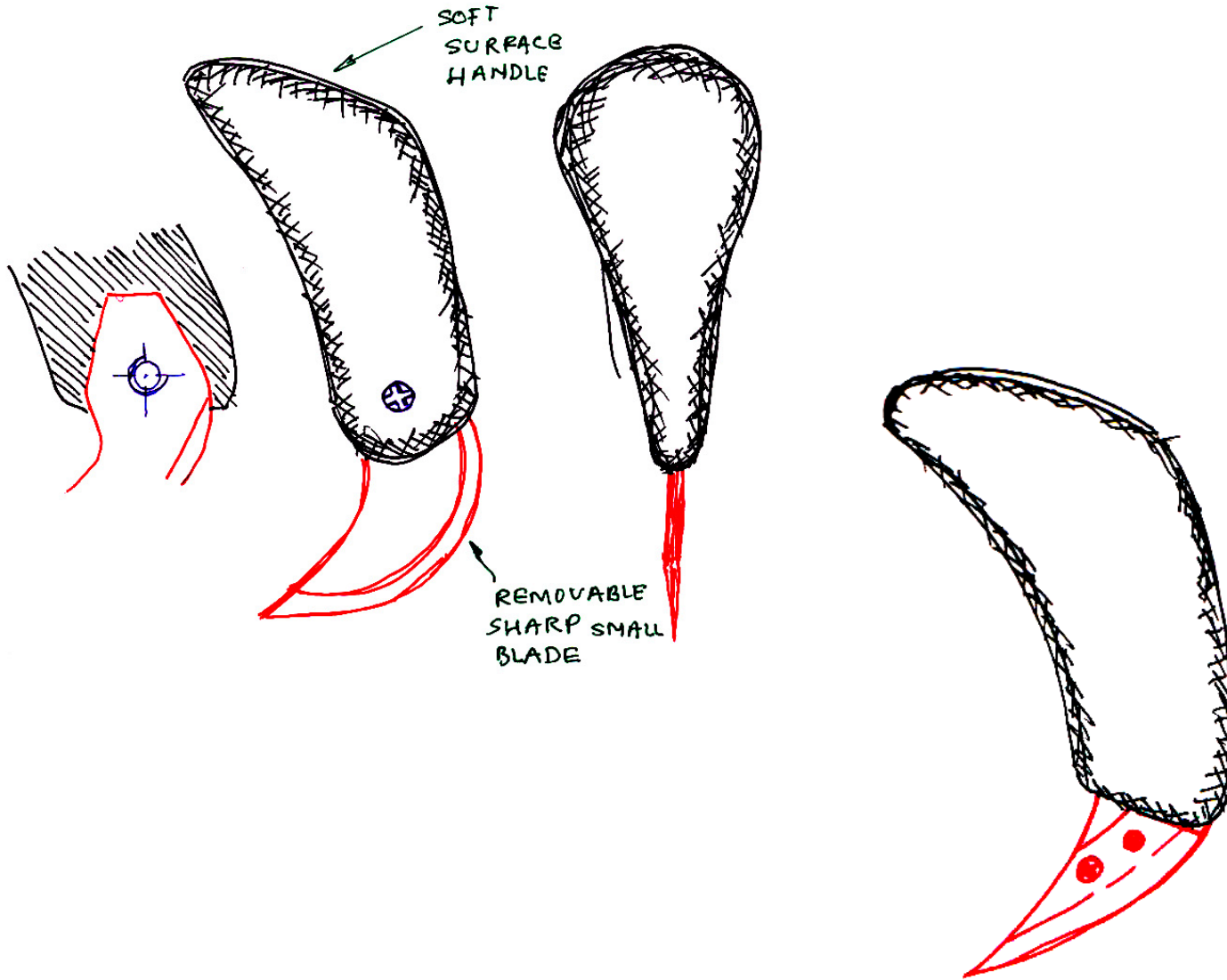

Idea 2

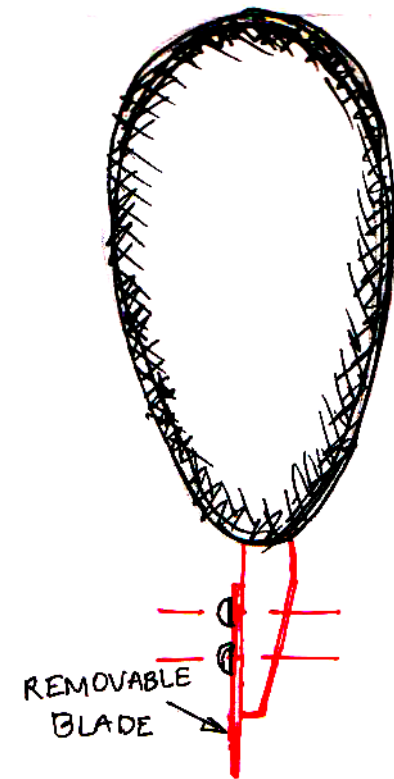

Idea 3

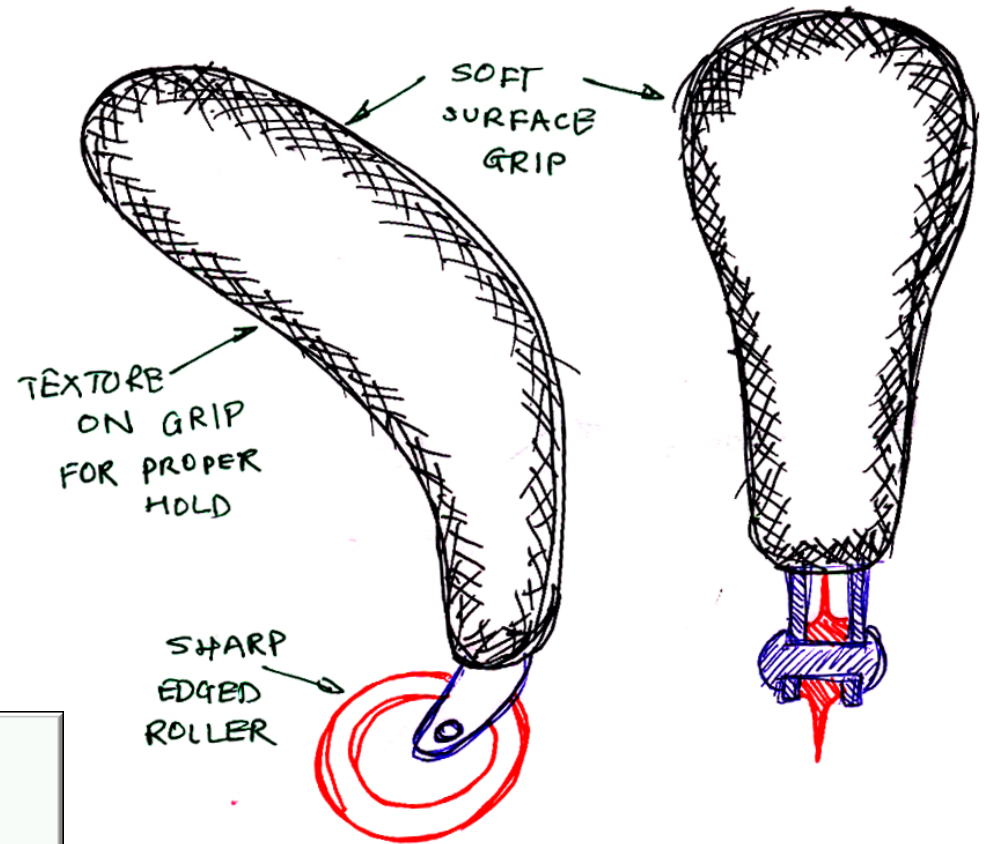

Idea 4

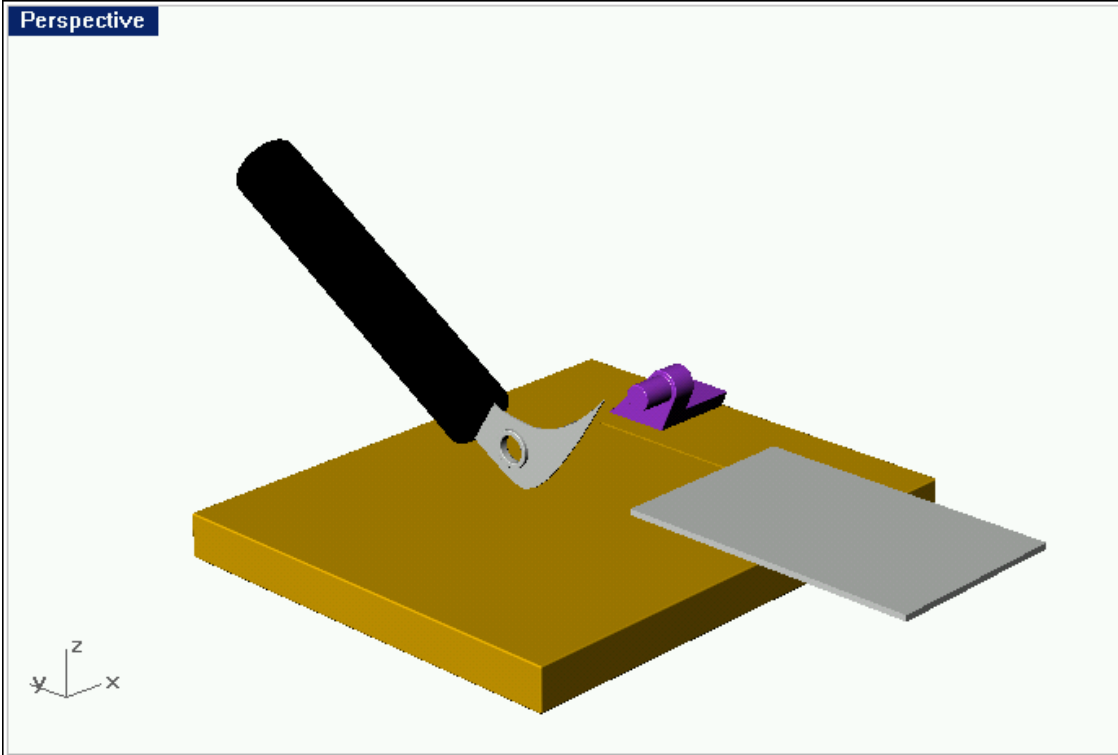

Idea 5

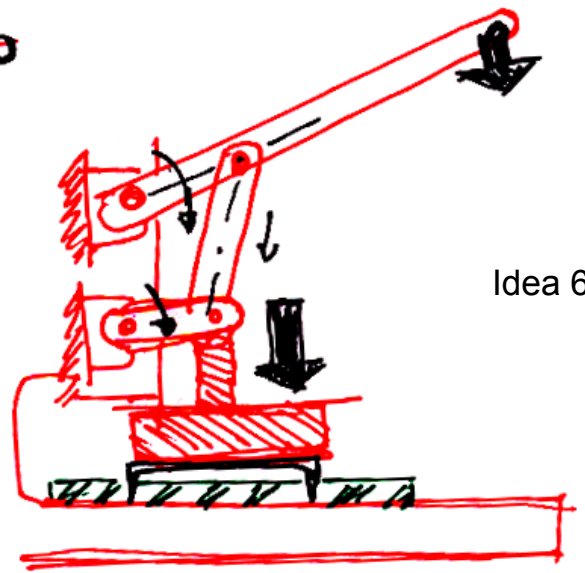
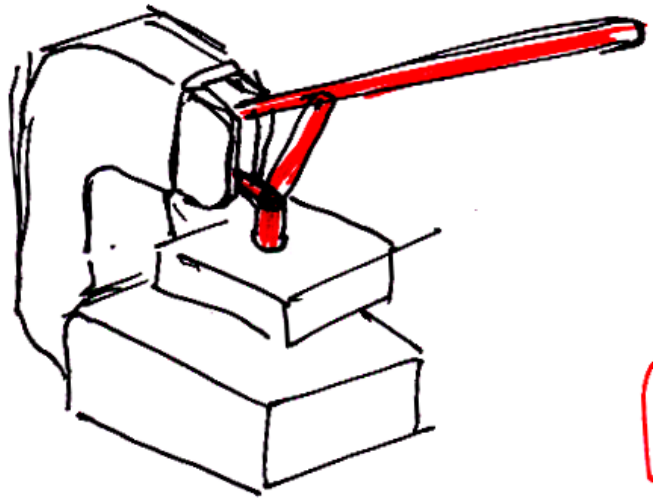
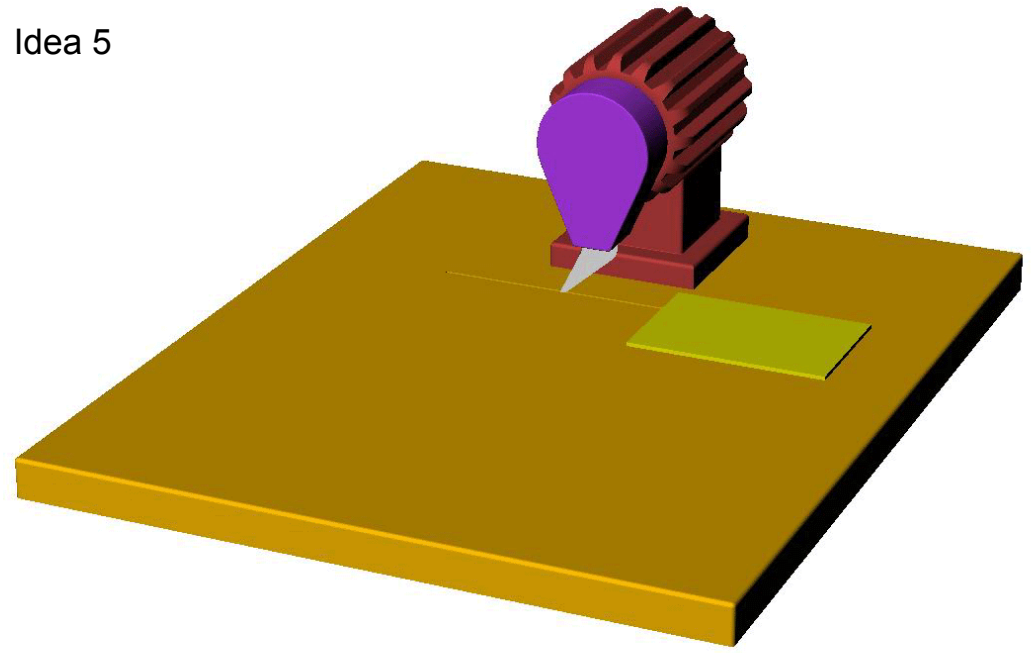

Idea 6

IDEA TESTING FOR CUTTING TOOL

Few initial ideas which were tested

The user feedback :-

- Need a sharp point at the start of cut.
- Dislike the shape of tool.
- Like the grip & it's orientation.



The user feedback :-

- Dislike the small shape of blade.
- Like the grip & it's orientation.



IDEA TESTING FOR CUTTING TOOL

Testing idea 4 –
first experimental model

A rod holed & welded over a ms sheet metal piece for pivot housing

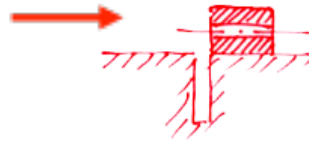

A piece of rod was welded at the end of rapi

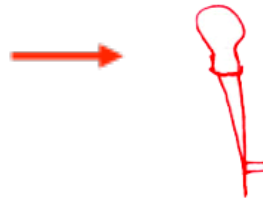

The guide was made by ms sheet metal strips screwed in wood base

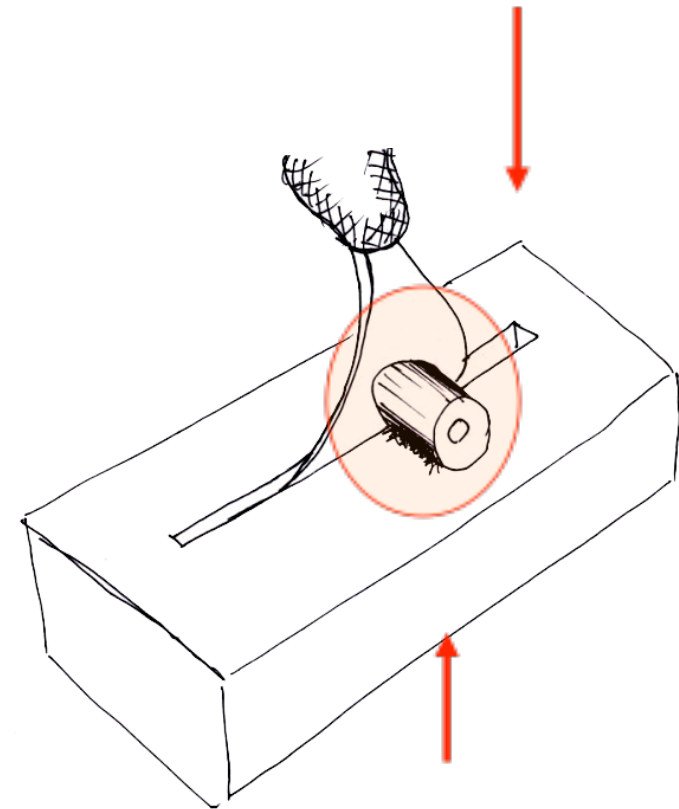

This works but the bush obstructs the leather movement

IDEA TESTING FOR CUTTING TOOL

Testing the idea 4 –
second experimental model

The problems

:-

✓ Rapi when pivoted above the surface.

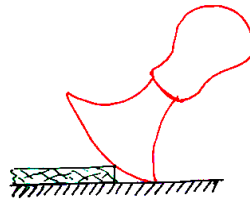

✗ Rapi when pivoted below the surface

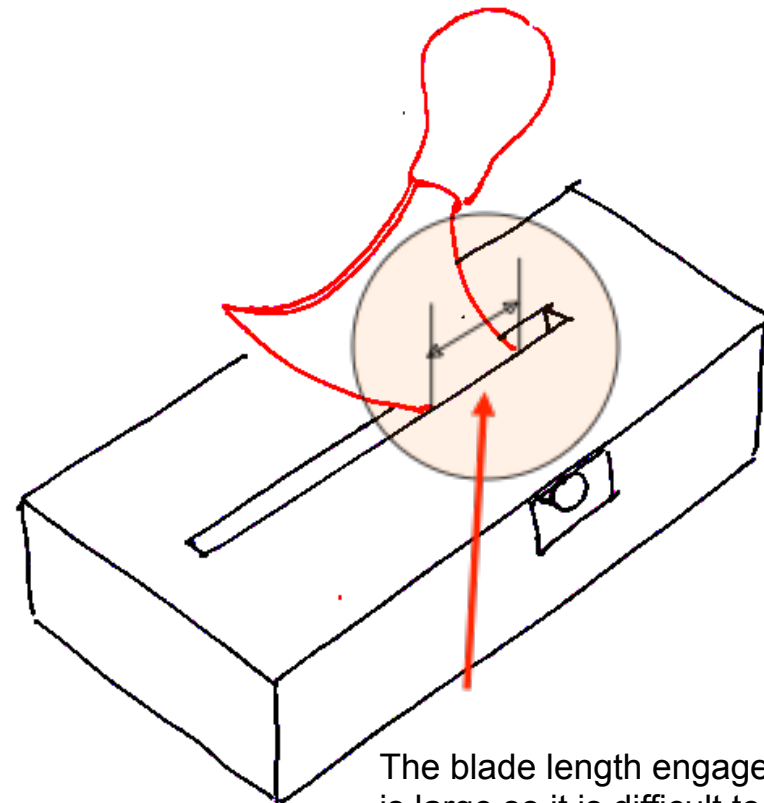
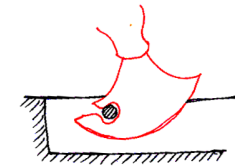
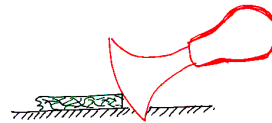

The blade length engaged while cutting is large so it is difficult to cut a curvilinear profile

IDEAS FOR SEWING TOOL

Idea 1

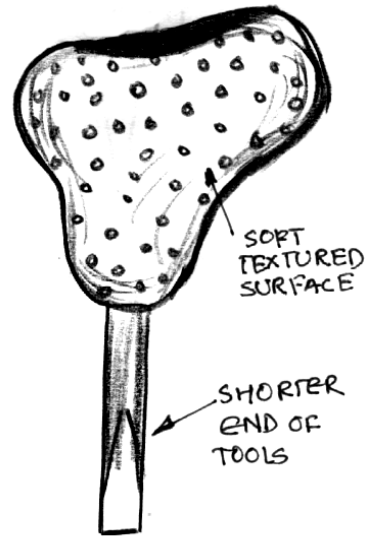
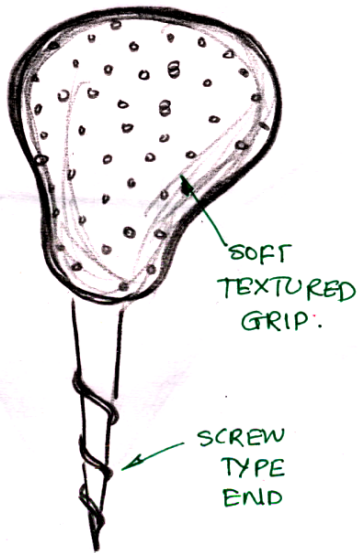

Idea 2

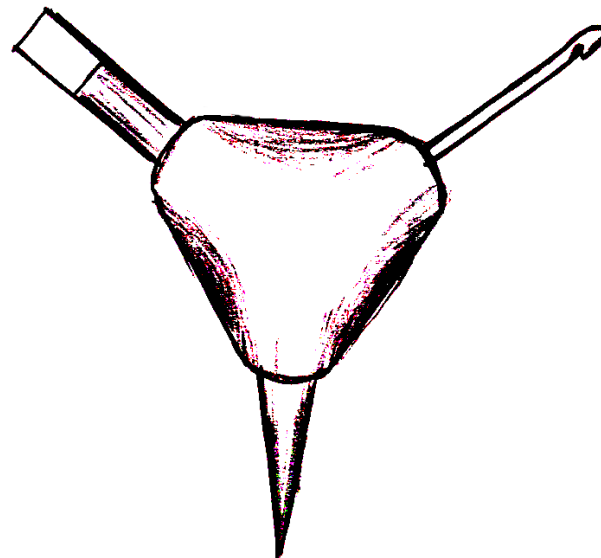

Idea 3

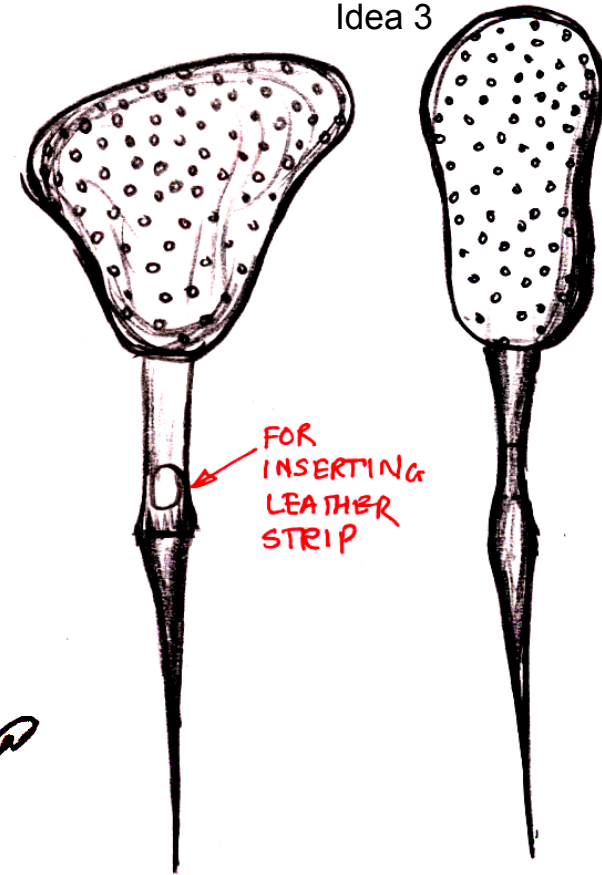

Idea 4

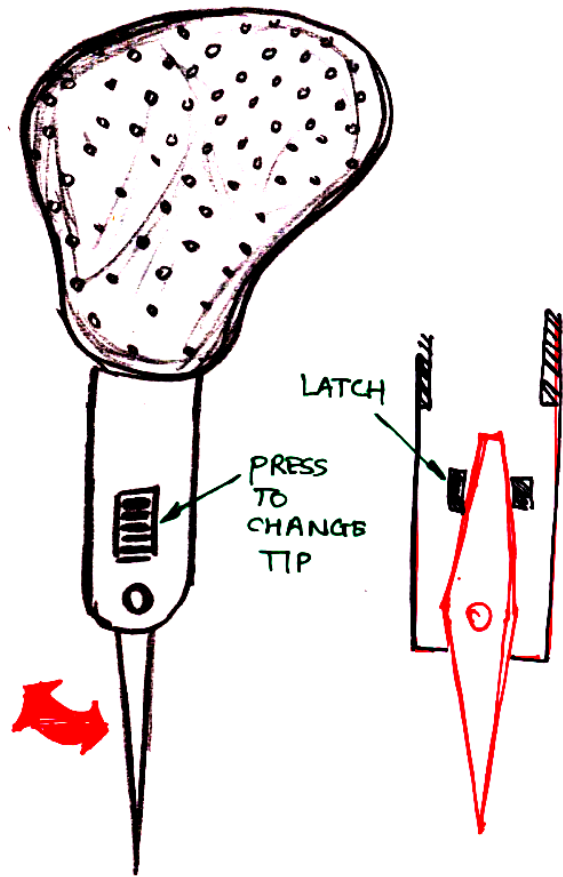

Idea 5

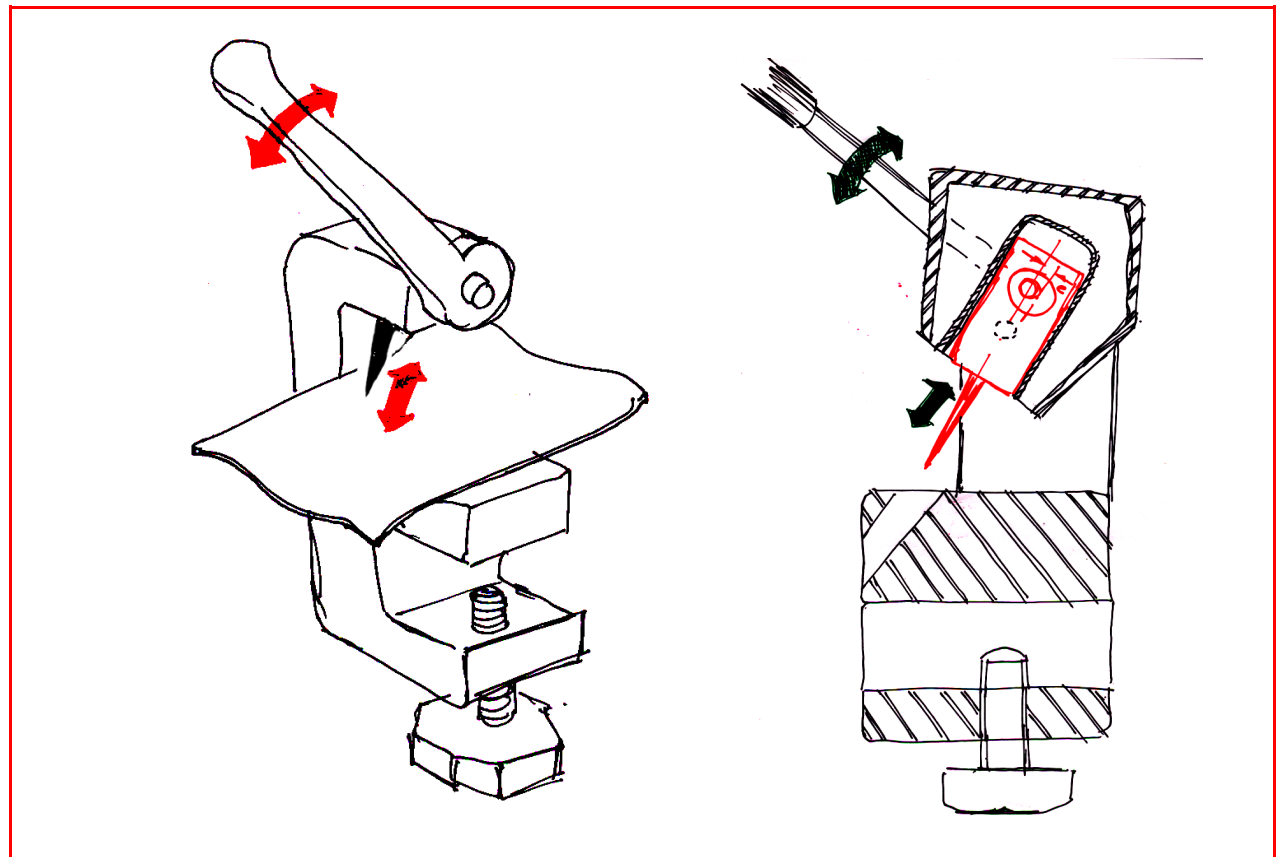

EXPLORATION FOR MECHANISM FOR IDEA 5

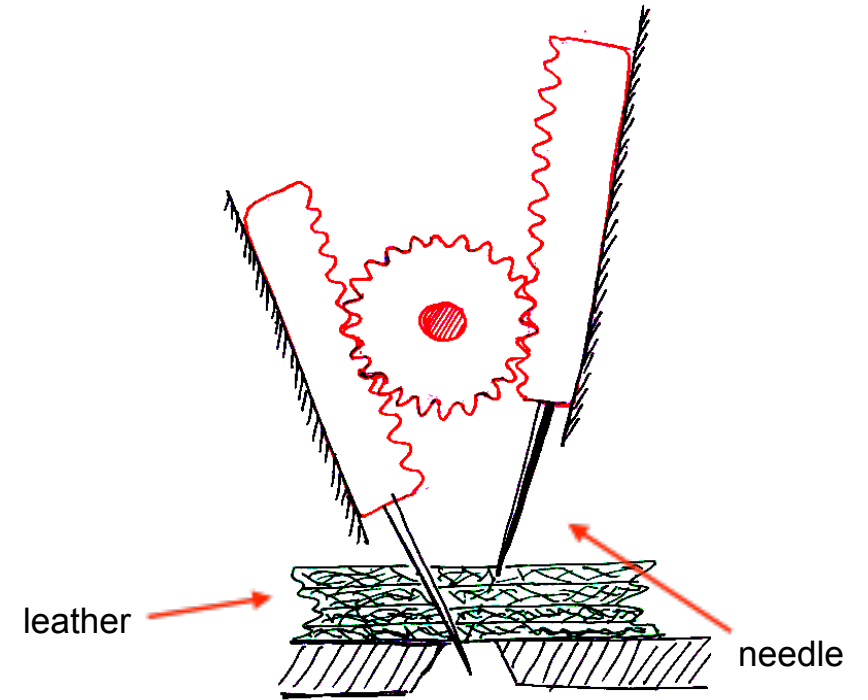
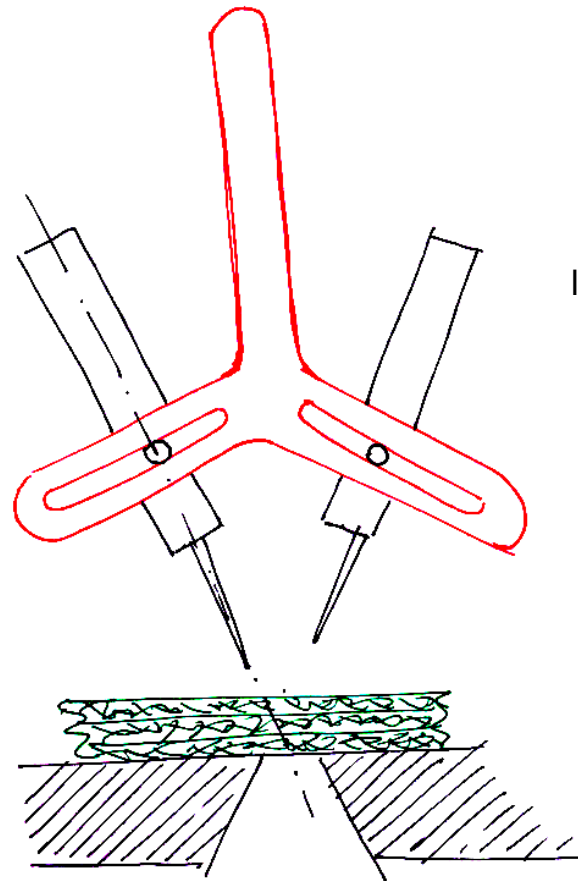
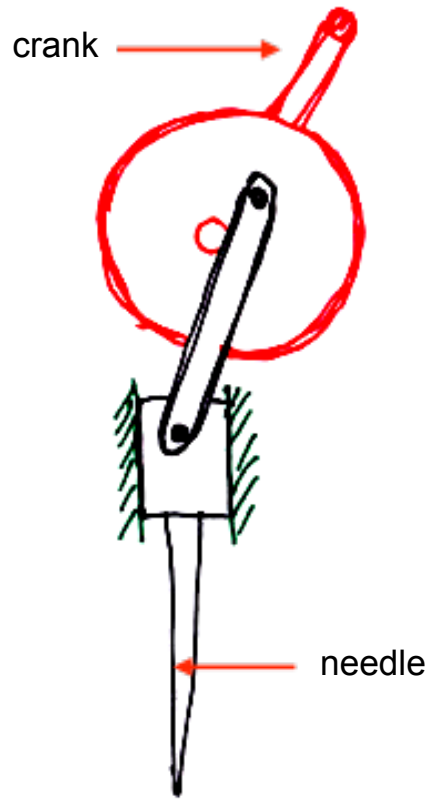

THE SELECTED MECHANISM AND FIRST CONCEPT

The rack and pinion mechanism

This is the simplest mechanism for this concept. It is an optimized solution, considering the angle of working, force input & the size of the overall product.

The working of concept

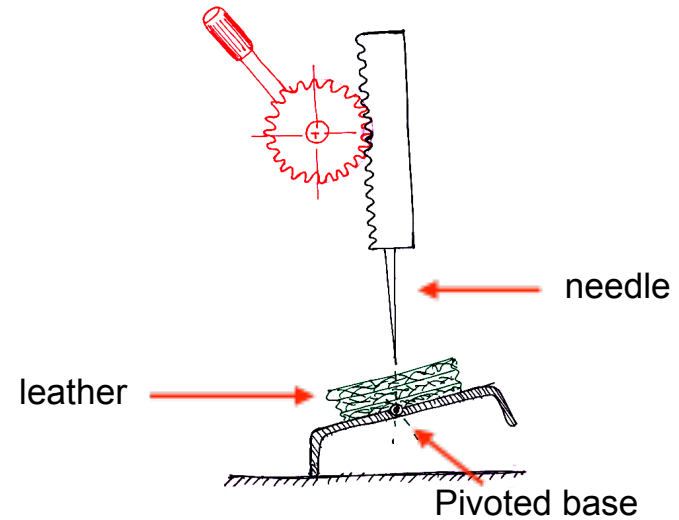
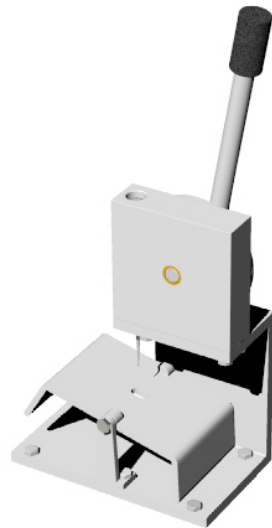

Feasibility of the mechanism

An actual trial was conducted with help of the drilling machine by attaching a needle and without rotating the spindle.

EXPLORATIONS FOR FINAL CONCEPT OF CUTTING TOOL

Form exploration

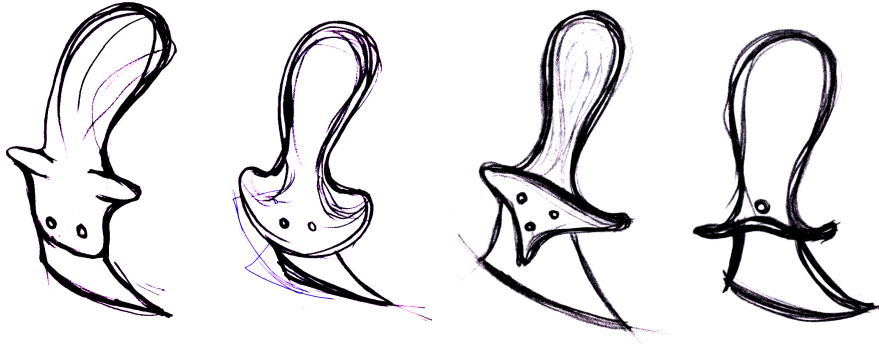

FINAL DESIGN FOR CUTTING TOOL

This is developed from the combined concept of concept no. 1 and 2. the blade has a slot so that when it wears then one can loose the screw and bring a part of blade out for further use. The screws are tapped on a metal plate which is inserted in a half part of the tool body made from poly propylene.

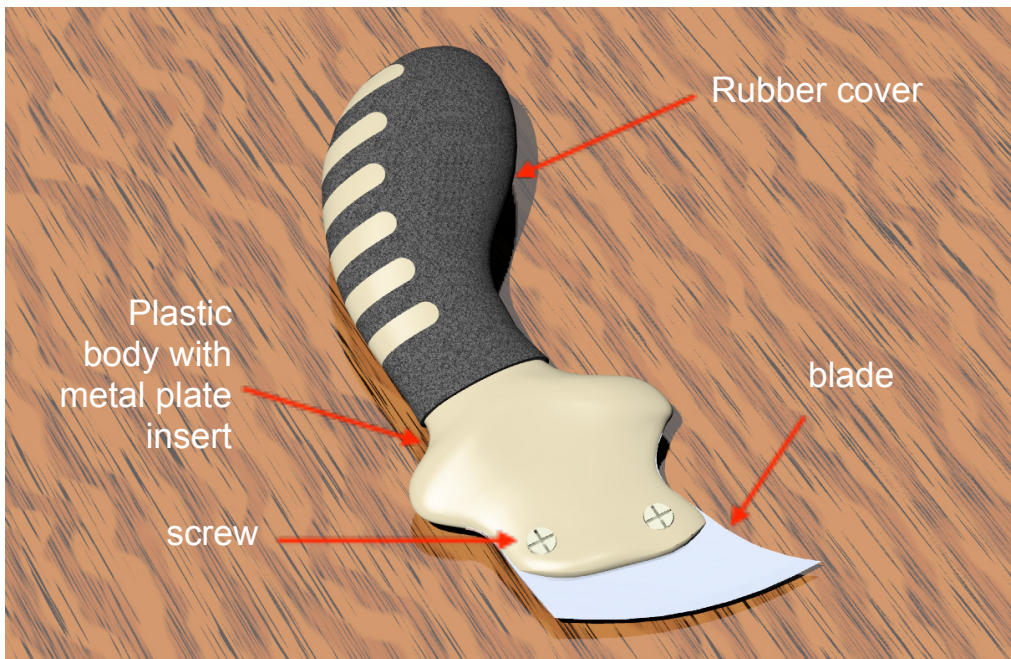

EXPLORATIONS FOR FINAL CONCEPT FOR SEWING TOOL



Stage
1

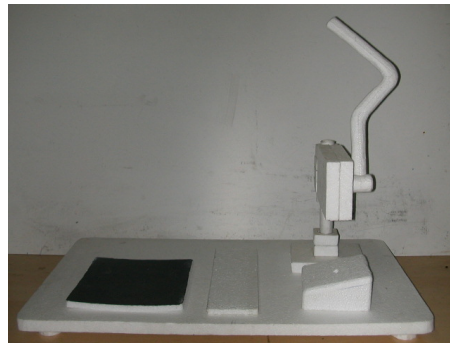

Stage
2



Stage
3

FINAL DESIGN FOR SEWING TOOL

This tool developed along with the worktable of the cobbler. This helps to make a hole for sewing. Also the needle can be removed, giving possibility to attach other tool such as for embossing.

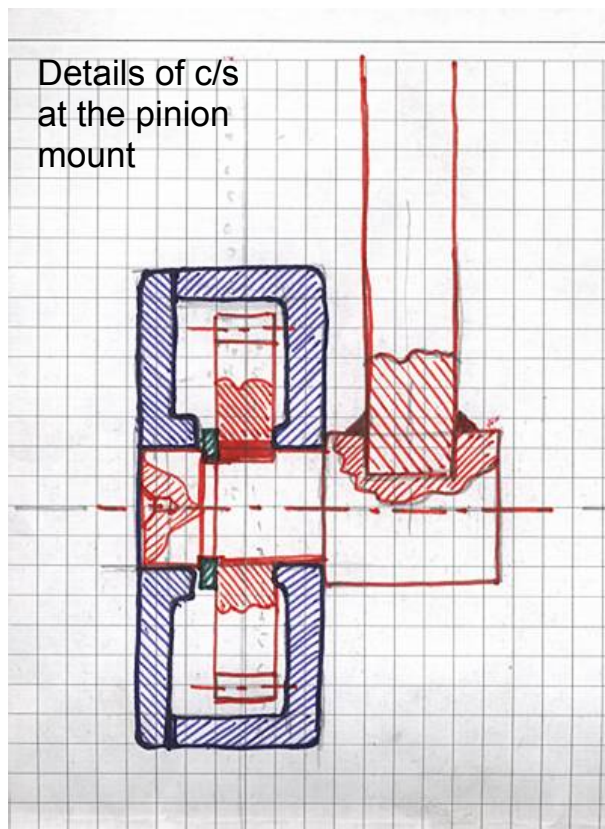
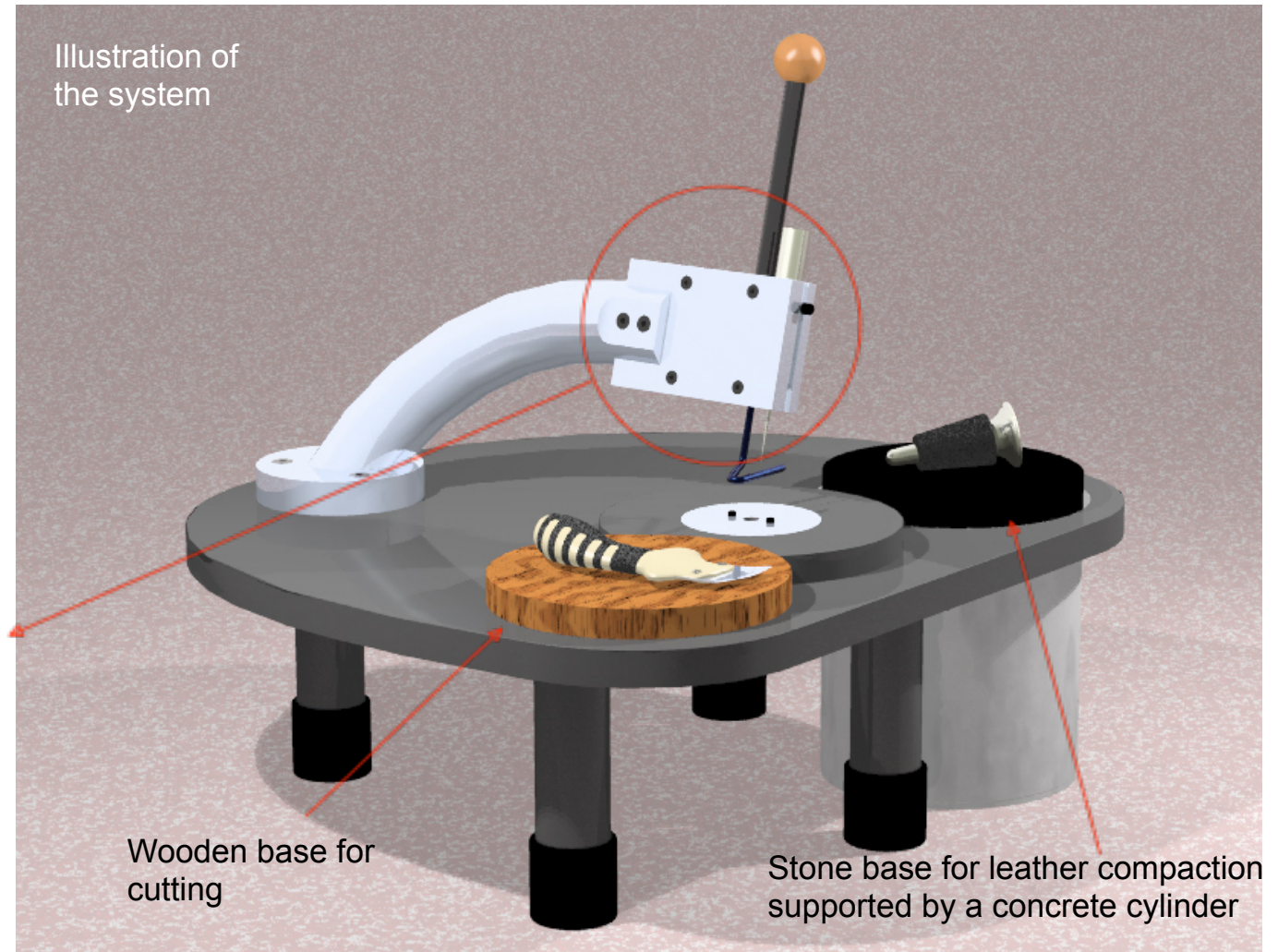

Illustration of the system



The work surface for cutting is very close with the sewing as these two activities takes place one after another through out the chappal making. The total workplace is raised by certain height so that the visibility is also good. This also improves the posture.

FINAL DESIGN FOR SEWING TOOL

Mock – up model
from top

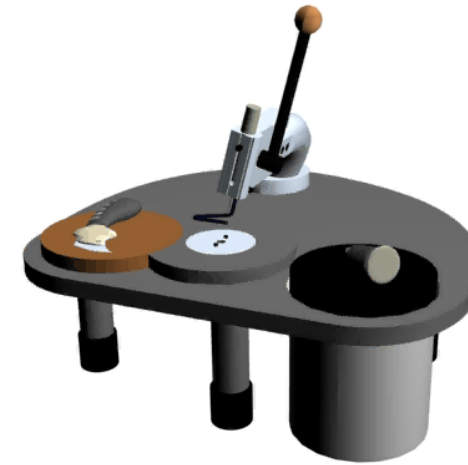

Mock – up model



Mock – up model
from side



ASSEMBLY DRAWING FOR CUTTING TOOL

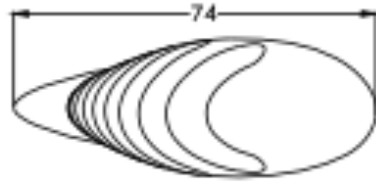

TOP VIEW

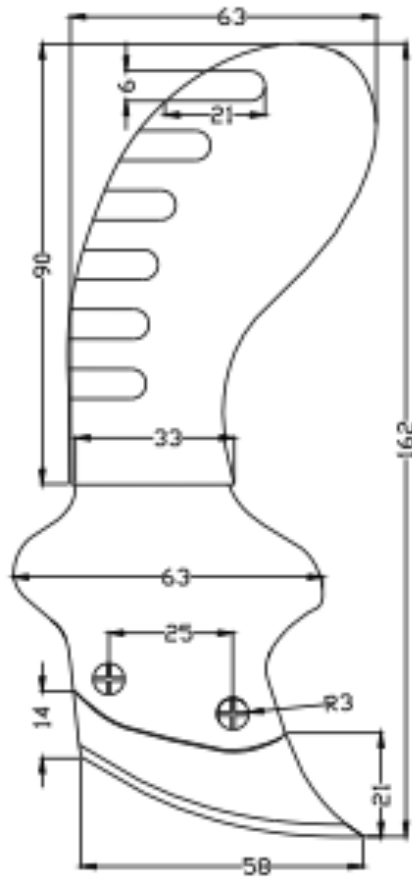

FRONT VIEW



SIDE VIEW

ASSEMBLY DRAWING FOR SEWING TOOL

