

PROJECT III

“Design Intervention for Clubfoot Abduction Orthosis”

By
Rajat
176130006

Guide
Prof. Avinash Shende



Industrial Design Centre
IIT-Bombay

APPROVAL

The Industrial Design Project-III,
entitled “Design Intervention for Clubfoot Abduction Orthosis”
by Rajat Patle is approved in partial fulfilment of the requirement of
Master’s Degree of Industrial Design at Industrial design centre, IIT-Bombay.

Guide

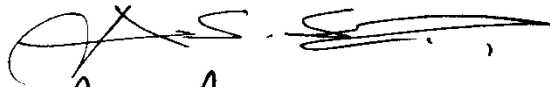

Chairman



Internal Examiner



External Examiner



Date 13-06-2019

DECLARATION

The written submission is a part of my report, “Design intervention for Clubfoot Abduction Orthosis” is done as a Project-3 for post graduation program at IDC, IIT Bombay, under the guidance of Prof. Avinash Shende.

I here by declare that the thoughts, ideas and words in this document are original and appropriate references are cited wherever due. I understand that the violation of the above can cause disciplinary action by the institute.



[12-11-2018]

Rajat

176130006

IDC-IIT Bombay

ACKNOWLEDGMENT

It is my pleasure to thank people who made this project possible.

I would like to express my sincerest gratitude to my guide Prof. Avinash Shende with his enthusiasm, inspiration, and great efforts to explain things clearly and simply. He helped make this project fun for me.

Also I would like to thank all other faculty members who gave me feedback about the project at each stage during this project, Without whom it would have been difficult to complete.

I also express my gratitude to Prof. B Ravi, Dr. Roopesh Gyar, Dr. Sourabh Sinha and other Doctors at Clubfoot Clinic at B J Wadia Hospital , Dr. Atul Bhaskar , NGO staffs and Users whom I have visited, they helped me very patiently with my constant enquiry during my user study and interviewing sessions.

I would like to thank my friends of IDC for continuously inspiring and encouraging me to work hard and also the workshop crew of IDC.

ABSTRACT

Many children around the world are born with Clubfoot every year. Not all of them are attended with proper care and treatment. There are NGOs that with the cooperation of local public hospitals help the privileged and unprivileged children to access and follow up with the treatment throughout.

However, there exists an unsure or unreliable reporting of prescribed bracing usage by parents in some cases, which can lead whole treatment to a repeat or a surgery to be followed sometimes.

This project focuses on improvising upon the conventional Club foot Orthosis for better compliance and true monitoring of prescribed usage.

CONTENTS

	Chapter	Title	Page No.
	1	Introduction to Clubfoot	1
	2	Child Growth & Motor Skills Development	13
	3	Field visits and User Study	19
	4	Market study	27
	5	User-Product Intercation	35
	6	Proof of Concept	49
	7	Design Brief	55
	8	Ideation	59
	9	Design of Brace footwear	75
	10	Design Concepts for Orthosis	85
	11	Final Concept	95
	12	User Testing & Feedback	127
<i>I</i>	<i>APPROVAL</i>		
<i>II</i>	<i>DECLARATION</i>		
	13	Branding	131
<i>III</i>	<i>ACKNOWLEDGEMENT</i>	<i>Future Scope</i>	135
		<i>Conclusion</i>	137
<i>IV</i>	<i>ABSTRACT</i>	<i>References</i>	139

LIST OF TABLES

Table no.	Title	Page No.
1.1	Grade classification	9
1.2	Pirani Score Record Sheet	11

Chapter 1

Introduction to Clubfoot



FIG. 1.1
CLUB RIGHT FOOT [UNILATERAL
CLUB FOOT]

WHAT IS CLUBFOOT?

Clubfoot is a birth deformity in which an infant's foot is curved towards the body internally, often so severely that the bottom of the foot faces sideways or even upward. The clubfoot can affect one foot or both feet. Club foot in both feet is called as *Bilateral Clubfoot* & in one foot is called as *Unilateral club foot*.

Quick identification and immediate treatment helps correcting it. The leg affected with club foot may be smaller than the normal foot. Normally, half of the affected children have *Bilateral Clubfoot*. Some cases can also be associated with other problems too.

This condition can be diagnosed at birth or before birth with ultrasound during 18 to 21 weeks of pregnancy. Normally, the Males are identified with this condition about twice as frequently as females.

CAUSE OF CLUBFOOT

There is no identified cause of club foot presently. However, Genetic and Environmental factors are considered responsible for this as per the medical experts.

Basic foot anatomy

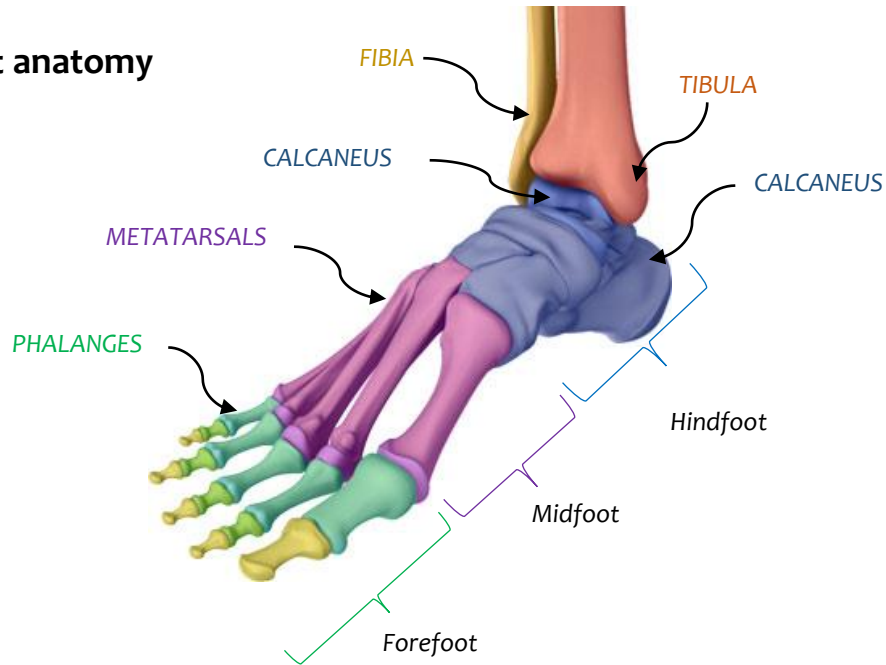

FIG 1.2. NORMAL FOOT

Figure 1.2 shows the general method of addressing the group of bones in the foot.

- The bones located from near tip of the foot [indicated in green and yellow color] are referred as *Front-foot*.
- The bones in the middle of the foot [indicated in purple color] are referred as *Mid-foot*.
- The bones located farthest from tip of the foot [indicated in blue color] are referred as *Hind-foot*.

Foot bone orientation in normal foot and club foot

- Figure 1.3 shows the difference between the normal foot and a club foot bone arrangement.
- The foot marked with red lines is affected by club foot and the angle between the red lines is an indication of the bone deviation from their original position.
- Though, the bones structure is not affected, the location & relative positions are.

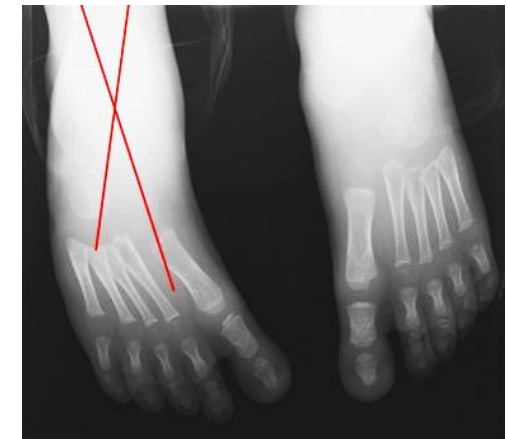

FIG 1.3. X-RAY IMAGE OF UNILATERAL CLUBFOOT

Statistics



As per WHO

- Clubfoot affects 1 lakh children worldwide, making it one of the most common birth defects in the world.
- Left untreated, the condition causes severe lifelong disability. *80% of untreated clubfoot are found in developing countries.*
- A patient who undergoes surgery will require two to three more surgeries over his lifetime.
- At 30 years old, a patient who underwent surgery will have a quality of life similar to a 50 year-old patient with Parkinson's Disease[8].



As per Miracle Feet India,
Estimated cases every year in India are around
35,000[11]

Treatment of Clubfoot



FIG 1.4. CASTING PROCESS IN PONSETI METHOD

Following discussed are the three way of treating clubfoot.

1

Ponseti Method

Most clinically practised and efficient method.

2

French Method

This incorporates stretching, mobilization, and taping.

Done by a physical therapist who has specialized training and experience.

3

Surgery

In cases of severe deformities, which do not respond to stretching, surgery may be needed to adjust the tendons, ligaments, and joints in the foot and ankle.

- The Ponseti method is a non-invasive, low-cost procedure to correct clubfoot with a 98% success rate.
- It consists of manually aligning the child's foot with the application of a series of casts over 6 to 8 weeks as shown in figure 1.4.
- It can take as little as 5 casts and 20 days to give a child a new chance at life.
- Once the inward bending is improved, the Achilles tendon is often cut, and braces are worn until the age of four. Initially, the brace is worn nearly continuously and then just at night. In about 20% of cases, further surgery is required.

Tenotomy

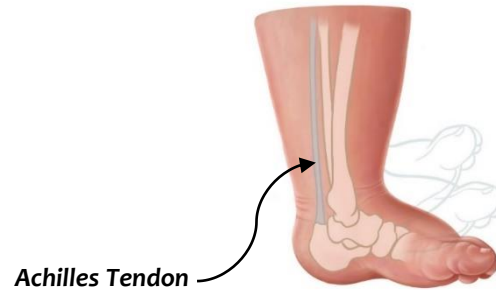

FIG.1.5. ACHILLES TENDON

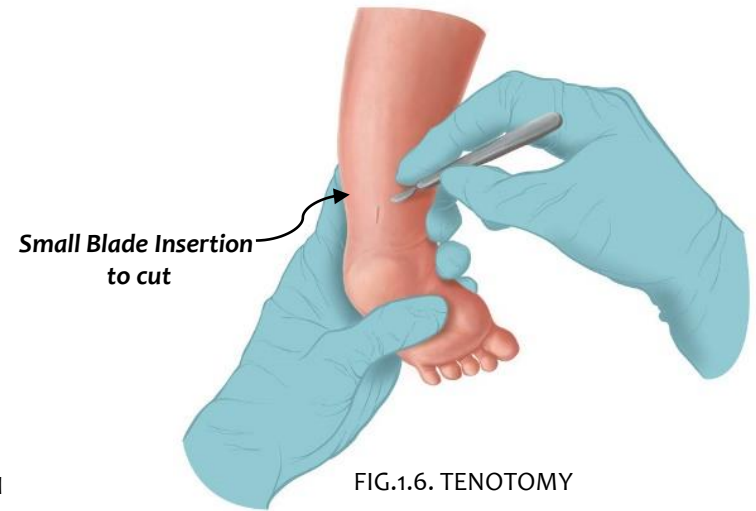

FIG.1.6. TENOTOMY

- Tenotomy is the invasive procedure.
- It consist of cutting the Achilles tendon, as indicated in the figure 1.5, located around the hind-foot.
- It is performed by pricking the elastic tendon, as shown in figure 1.6, with a small blade to tear on its own creating a popping sound. The sound indicates that the tendon is torn.
- This procedure is performed only in few cases where the foot may not respond to the casting process.
- The child is again subjected to few cast after the Tenotomy.

What If Untreated ?



FIG.1.7. LIVELIHOOD OF A PERSON WITH CLUBFOOT



FIG.1.8. ACHILLES TENDON

The condition of clubfoot can be corrected at an early stage and becomes difficult to treat if neglected!

Further, Employment & social stigmas are life challenges especially in underdeveloped countries.

Irrespective of the type or severity, clubfoot will not improve on its own.

A child with an untreated clubfoot-

- Will walk on the outer edge of the foot as shown in figure 1.8
- Develops, sometimes, painful calluses
- Faces difficulties in wearing any foot wears even socks!
- Can have painful feet for lifetime that often severely limit physical activities.

Grading Of Clubfoot

- The clubfoot deformity can be grade as per the degree of deformity. The figure 1.9 indicates the range of deformity varying from benign to severe condition. A zero degree indicate the normal foot and a value of 90 degree and above indicates the severe clubfoot deformity.
- Every range of degree is assigned a score. And depending on the total score calculated, in 4 different manner as shown in fig. 1.9, the clubfoot is graded. Table 1.1 shows the score based classification of clubfoot. Figure 1.10 shows the method of approximately calculating the angle of deformity.

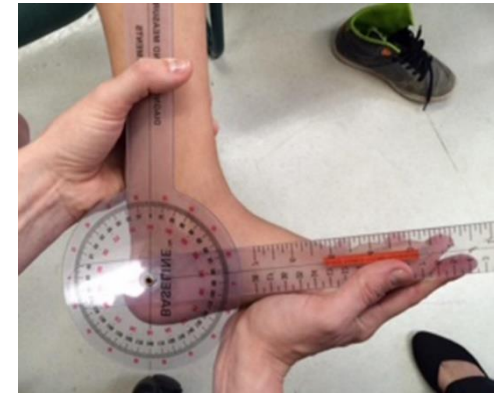

FIGURE 1.10 MEASURING THE ANGLE

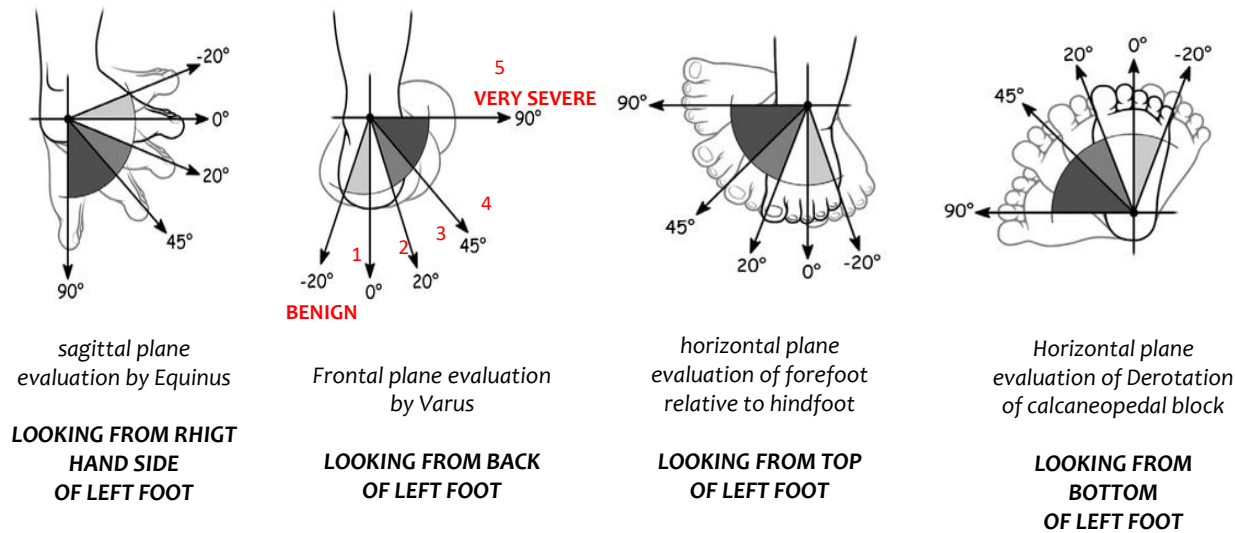

FIGURE 1.9 GRADING OF CLUBFOOT

TABLE 1.1 GRADE CLASSIFICATION

GRADE	TYPE	SCORE
1	BENIGN	<5
2	MODERATE	=5<10
3	SEVERE	=10<15
4	VERY SEVERE	=15<20

Scoring of Clubfoot

- The Pirani Scoring is a very simple and reliable way to determine severity and check on the progress in the examining and treatment of Clubfoot.
- A foot can be examined in a minute without use of any equipment.
- The measurements are taken while the examiner is gently correcting the foot with least possible efforts and no discomfort.
- Scoring the foot at each visit during treatment enables the health care worker treating the child to document how the foot is responding to manipulation and casting.

The Pirani Scoring System is based on following 6 Clinical Signs of Contracture as shown in chart 1.11.

3 Signs in Midfoot are

- Medial Crease
- Curved Lateral Border
- Lateral Head Talus

3 Signs in Hindfoot are

- Posterior Crease
- Empty Heel
- Rigid Equinus

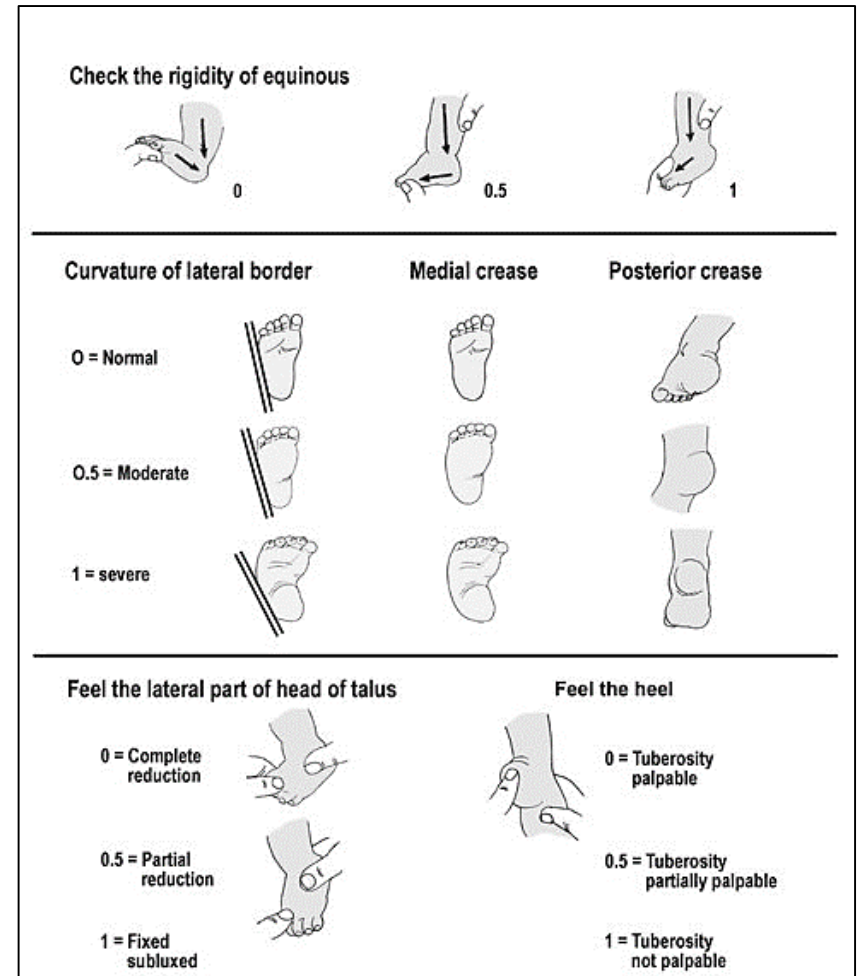

FIG. 1.11 CHART OF PIRANI'S SCORING SYSTEM

Pirani Score Record Sheet

- As per the record sheet shown in table 1.2, the child is scored depending on Severity from 0, 0.5, or 1.
- Total Score varies from 0 to 6 and is the sum of Midfoot and Hindfoot Contracture Scores.

DATE	VISIT 1		VISIT 2	
SIDE	Right	Left	Right	Left
Medial Crease				
Curved Lateral Border				
Lateral Head Talus				
MID FOOT CONTRACTURE SCORE(MFCS)				
Posterior Crease				
Empty Heel				
Rigid Equinus				
HIND FOOT CONTRACTURE SCORE(HFCS)				
TOTAL SCORE				

TABLE 1.2 PIRANI SCORE RECORD SHEET

Chapter 2

**Child Growth & Motor Skills
Development**

This chapter constitutes some standard data as per sources mentioned, relevant to *children growth, development, child's color preferences and perception.*

The data was helpful for design the *brace, footwear and the accessories.*

The chart shows the motor skills development of a child during the growth in Months[4].

This is the normal duration of age when the child is wearing brace for around 23 hours a day.



Age	Motor
1-1.5 months	<ul style="list-style-type: none"> • When held upright, holds head erect and steady.
1.6-2 months	<ul style="list-style-type: none"> • When prone, lifts self by arms; rolls from side to back.
2.1-2.5 months	<ul style="list-style-type: none"> • Rolls from tummy to side • Rests on elbows, lifts head 90 degrees • Sits propped up with hands, head steady for short time
3 months	<ul style="list-style-type: none"> • Prone: head held up for prolonged periods • No grasp reflex
5 months	<ul style="list-style-type: none"> • Holds head steady • Goes for objects and gets them • Objects taken to mouth
6 months	<ul style="list-style-type: none"> • Transfers objects from one hand to the other • Pulls self up to sit and sits erect with supports • Palmar grasp of cube hand to hand eye coordination
6-9 months	<ul style="list-style-type: none"> • Teething starts. Try to bite/eat objects.
7 months	<ul style="list-style-type: none"> • Responds to their name
9-10 months	<ul style="list-style-type: none"> • Wiggles and crawls • Sits unsupported • Picks up objects with pincer grasp • Learns to drop objects

The chart addresses the sequence of activities, a child is capable of doing, during the aging process from 1 month to 6 years. This information was helpful in designing accessories for the brace.

Age	Motor
1 year	<ul style="list-style-type: none"> • Stands holding furniture • Stands alone for a second or two, then collapses with a bump
18 months	<ul style="list-style-type: none"> • Can walk alone • Picks up toy without falling over • Gets up/down stairs holding onto rail • Begins to jump with both feet • Can build a tower of 3 or 4 cubes and throw a ball • Supinate grasping position usually seen as first grasping position utilized.
2 years	<ul style="list-style-type: none"> • Able to run • Walks up and down stairs 2 feet (61 cm) per step • Builds tower of 6 cubes • Goes down stairs one foot per step • Postural capacity needed to control balance in walking not attained yet
4 years	<ul style="list-style-type: none"> • Skips on one foot • Imitates gate with cubes • Copies a cross • Between 4 and 6 years, the classic tripod grip develops and is made more efficient.
5 years	<ul style="list-style-type: none"> • Skips on both feet and hops. • Begins to be able to control balance not attained at 3–4 years of age • Begins to be able to control gravitational forces in walking • Draws a stick figure and copies a hexagonal based pyramid using graphing paper • Gives age
6 years	<ul style="list-style-type: none"> • At this age, until age 7, adult muscle activation pattern in walking is complete. • Leads to head control and trunk coordination while walking, by at least age 8. • Mechanical energy transfer exists • Knows right from left and number of fingers

AS PER AMERICAN OPTOMETRIC ASSOCIATIONS [24]

The following are some age-appropriate activities that can assist an infant's visual development.

Birth to four months

- Use a nightlight or other dim lamp in your baby's room.
- Change the crib's position frequently and change your child's position in it.
- **Keep reach-and-touch toys within your baby's focus, about eight to twelve inches.**
- **Talk to your baby as you walk around the room.**
- Alternate right and left sides with each feeding.

Five to eight months

- **Hang a mobile, crib gym or various objects across the crib for the baby to grab, pull and kick.**
- Give the baby plenty of time to play and explore on the floor.
- **Provide plastic or wooden blocks that can be held in the hands.**
- **Play patty cake and other games, moving the baby's hands through the motions while saying the words aloud.**

Nine to twelve months

- Play hide and seek games with toys or your face to help the baby develop visual memory.
- **Name objects when talking to encourage the baby's word association and vocabulary development skills.**
- Encourage crawling and creeping.

One to two years

- Roll a ball back and forth to help the child track objects with the eyes visually.
- Give the child building blocks and balls of all shapes and sizes to play with to boost fine motor skills and small muscle development.
- Read or tell stories to stimulate the child's ability to visualize and pave the way for learning and reading skills[24].

The above mentioned information was helpful to understand what parents/guardian should do to compliment their child's growth, as the child ages, enhancing their physical and mental development.

The Bright Color Appeal

As per AOA[American Optometric Association], USA

“At birth, babies' vision is abuzz with all kinds of visual stimulation. While they may look intently at a highly contrasted target, babies have not yet developed the ability to easily tell the difference between two targets or move their eyes between the two images[24]”

Children tend to be attracted to the bright block colors of the color wheel rather than pastels or muted blends. **Primary colors red, yellow and blue, and secondary colors green, orange and purple, are more appealing than light shades of pink and beige or neutral shades of gray and brown.** For this reason, the food and beverage industries, as well as the toy industry, use bright colors to market children's products[5].

As per an article from *Sciencing.com*,

Children take in the world around them through their eyes, and bright colors are one of the first aspects of sight that help them distinguish form and categorize objects. These colors appeal to young children, as they are easier for them to see. **At about 5-months old, children can see colors with their still-developing vision, though distinguishing bright colors comes easier to them.** As children age, they continue to be drawn to brighter colors. **Bright colors catch young children's eyes because they help kids to distinguish objects from one another in their field of vision. Children spend more time looking at bright colors as opposed to looking at muted shades or pastels[25].**

The above mentioned information was helpful in deciding the choice of colors.

Chapter 3

Field visits and User Study

A basic questionnaire was made prior meeting the expert Doctors based on the initial theoretical enquiry about the Clubfoot as discussed in the Chapter 1.

What makes parents to take off the braces on their own?

What reason do parents tell when asked about them being impatient?

Why there is a need for continuous or real-time assessment of club foot in the treatment?

Do putting braces always follows the surgery or the braces also can be used prior surgery? Which one is better to follow?

Under which conditions the surgery is must for the patient?

Do the conduct of Ponseti Method has any relation with the growth of bones in infants? If yes, how the Bone growth and the treatment complements each other?

What is the proper way of plastering the cast on the foot?

In what way the bones are arranged during casting a plaster?

Is there any pressure exerted on the thigh bones during casting a plaster?

Is thigh/calf bone considered as a reference during casting a plaster?

How advantageous would it be to consider the thigh/calf bone as a reference for setting angles in designing the brace ?

Why the present method of measuring club angels is clinically inefficient to measure the progress in a patient with braces?

Any kind of complain/feedback/advice/difficulties/insight presented by parents for the present design of braces?



Creating Questionnaire

Meeting Doctors

Expertise dealing with clubfoot are few. So, initially Dr Nisha, CMO at IIT B Hospital, was approached to help find an expertise practising in paediatric orthopaedics.

With some reference from BeTic IIT Bombay, team of Doctors at clubfoot clinic at B J Wadia Hospital was approached for further study.

Later, Dr Sourabh Sinha from B J Wadia Hospital appeared to be the consulting expert for this project and this project work further was continued with his Support and supervision.

Also, Dr Atul Bhaskar, paediatric specialist at Hiranandani Hospital, help with interacting with a lot of parents at his clinic in Andheri West. He also shared some of his Brace collection for understanding the Brace as a product.

Visits



DR. NISHA

CMO
IIT-B HOSPITAL



DR. ALERIC & TEAM

Paediatric Specialist
B J WADIA HOSPITAL, PAREL



DR. ATUL BHASKAR

Visiting consultant
HIRANANDANI HOSPITAL



DR. SURESH CHAND

Asst. Paediatric Specialist
B J WADIA HOSPITAL, PAREL



DR. SOURABH SINHA

Visiting Consultant
BETIC, IIT-B



DR. BHUSHAN

Asst. Paediatric Specialist
B J WADIA HOSPITAL, PAREL

During initially visits to Dr Atul Bhaskar, paediatric specialist at Hiranandani Hospital, I was invited to his clinic for further study. At his clinic I got to see two patients of age around 24 days and 8 weeks old. The figure refers to the 24 days old baby girl being put on plaster.



USER 1

CLINIC – Children's Orthopaedic Clinic

CLINICIAN – Dr Atul Bhaskar

LOCATION - Andheri West.

AGE – 24 days old

CONDITION – Unilateral Clubfoot [Right]

The girl was diagnosed with clubfoot soon after her birth on the right foot.

A weeks gap was given to consult and inform parents about the situation, so that they cooperate well during the initial phase of treatment, which is the most crucial phase.

During this initial phase the babies normally cry a lot. But, the Ponseti method do not cause any pain to the baby during treatment.



Holding the leg at toe and knee



Start from the foot by holding it in a desired way



2-3 layers are casted one by one



Done !

Dr Atul demonstrated the whole procedure of holding the affected foot, examining the foot and plastering the foot. He also informed me and the family members of the baby about how to take care of the baby after the plastering is done , timely checking and indications if the baby is really facing some problem in the plastered foot.



USER 2

CLINIC – Children’s Orthopaedic Clinic

CLINICIAN – Dr Atul Bhaskar

LOCATION -- Andheri West.

AGE – 8 months old

CONDITION – Bilateral Clubfoot [Both Left & Right foot]



FIG. 3.5

It take very long to tie all laces & Baby kicks with other leg while putting braces



FIG. 3.6

Baby cries a lot after change !



FIG. 3.7

Black Marks on Skin

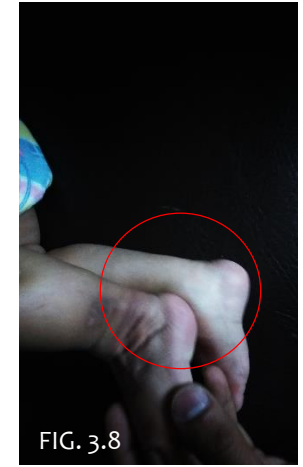

FIG. 3.8

Previous injury & History of Bleeding

- The above shown figures refer to the second patient who was 8 weeks old.
- The plastering was over for this patient and she was on brace since last 3 months. She was given a steinbeek brace by Dr. Atul.
- The parents while sharing their experience of using this orthosis.
- They reported about the black marks on skin of the foot that were caused due to the exposed joinery in the footwear, some stress points on the foot where the baby faced bleeding due rough contact as shown in figure 3.8, skin blackening as shown in figure 3.7 and swelling due to tight small bands used for fastening the orthosis.
- The crude appearance of the brace was not liked by the parents as it evoked a sense of pain and punishment they said.
- The mother of the child informed me about the difficulties she face during putting the brace on to the child. The child looses or kicks out the foot during she try to shoe the second foot after the first shoe is done.



USER 3

CLINIC – Clubfoot clinic at B J WADIA Hospital

CLINICIAN – Dr Alaric Arijoos, Dr Bhushan

LOCATION – Parel

AGE – 8 yrs. Old

CONDITION – Relapse of Clubfoot [Left]

- The 8 years old boy had gone through all the procedures of treatment right from he was diagnosed with clubfoot.
- It was almost an year later he completed the treatment, the neighbours and school teachers started noticing his improper way of walking and running all of a sudden.
- His mother was informed by them and he was brought to B J WADIA hospital for further treatment.
- A condition of relapse was identified in his left foot. A surgery was scheduled to deal the condition.
- The boy was not operated earlier and Tenotomy sometimes is required in such cases.
- Till then he was put on plaster on left leg as show in figure 3.9 and 3.10.



FIG. 3.9



FIG. 3.10



USER 4

LOCATION – Bangalore

AGE – 25 years

CONDITION – Bilateral Clubfoot

- The user was operated when he was 10 days old.
- He was never put to any brace during his treatment at Bangalore hospital.
- He was prescribed to wear shoe custom made after surgery for several years.
- He reported about the shoe being very rugged and painful.
- He has been suffering from painful feet and cannot stand for more than 2 hours even now.
- He has been facing difficulty in walking and running if done over a long period of time.
- Sometimes his pain stays over two days, making it difficult to commute.
- He prefers the pain caused due to shoes over the pain caused due to painful-feet as it helps him step well.

Key Insights

- Any kind of leniency in bracing can lead to relapse.
- Child takes around a week to adjust to the brace once the bracing protocol starts [as per the steinbeek orthosis Users and doctors recommending].
- Braces are circulated among the patients either when parents cannot afford the treatment or the no. of braces available is less.
- Visual inspection of exposed foot is must to avoid/realise any kind of damage/problems in plastered or braced foot.

Chapter 4

Market study

Ankle Foot Orthosis [AFO]

Figure 4.1 and 4.2 shows the AOF Orthosis.

PROs

- Light in weight
- Easy to Manufacture
- Cost Effective
- Best suited for holding foot in a neutral position

CONs

- Restricts Dorsiflexion as resembled in fig 4.3.
- Not suitable in walking kids as it keeps the foot in neutral position

Costs around Rs. 400 -800.
It Is Globally Used.



FIG. 4.1



FIG. 4.2

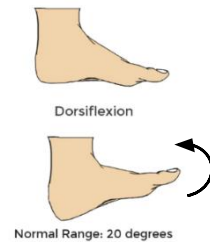

FIG. 4.3 DORSIFLEXION

Stanford Orthosis

Figure 4.4 and 4.5 shows the Stanford Orthosis.

PROs

- Light weight
- Easy to Manufacture
- Cost Effective
- Easy to Use as Shoes clip on and off
- Bars can be reused and recycled
- Injection-molded for global mass production

CONs

- Extremely difficult to clean
- Distant between the feet is constant

Costs around \$ 25



FIG. 4.4



FIG. 4.5

Iowa Orthosis



FIG. 4.6 IOWA BAR

Figure 4.6 shows the Iowa Orthosis.

PROs

- Less clutter
- Mechanical joints are not exposed to child
- Has 2 point flexibility – 30 & 60 degrees position

CONs

- Restricts Dorsiflexion
- Not suitable in walking kids as it keeps the foot in neutral position
- Has more weight due to use of metal.

Costs around 200 \$

Its is popularly used in China & USA

Dobb's Orthosis

Figure 4.9 shows the Dobb's bar

- Dobbs Bar enterprises sells three kind of braces.
- Its is popularly used in Canada, UK, Brazil & Japan.
- The brace itself cost around 120 \$.
- Its has flexibility to change angle of abduction length adjustment as per shoulder width.



FIG. 4.7 DOBB'S BAR

MARKELL SHOES
BY
MARKELL SHOE COMPANY



FIG. 4.8 MARKELL SHOE



FIG. 4.9 MARKELL SHOE

- This braces are to be wore with Markell's shoes which costs around \$ 100.
- To avoid kid's interaction with the mechanical joints, they are provide with cover costing around \$18.



FIG. 4.10 BAR COVER

The Denis Browne Bar

The figure 4.11 and 4.12 shows the Dennis Brown Bar PROs

- Light weight
- Easy to Manufacture
- Change of distance between the shoes is possible
- Most flexible in terms of changing angle of Abduction

CONs

- Uncomfortable while holding the kid.
- Very Expensive

Costs around \$ 100.

It Is Very Popularly used in UK



FIG. 4.11



FIG. 4.12 DENIS BROWN BAR

Steinbeek Orthosis

The figure 4.13 shows the Steinbeek Orthosis

PROs

- Light weight
- Easy to Manufacture
- Cheaper as compared to other braces

CONs

- Uncomfortable while holding the kid.
- Very Uncomfortable to wear on to kids and for kids to wear.
- Correction is made by bending the rod manual.
- Change of distance between the shoes is possible

Costs around Rs 1000

It is globally used and is well accepted by clinicians



FIG. 4.13 STEIN BEEK ORTHOSIS

Key Insights

- With the increasing size of brace, it becomes less portable.
- Metallic and edgy braces are difficult to handle.
- Any sort of exposed joinery is unsafe for growing kids.
- Lacing the shoe is time taking and often needs assistance.

Product Positioning

- The figure 4.17 shows a matrix of orthosis mapped orthogonal over cost and usability/compliance.
- The area, shaded inside the red lines, indicates a niche for the desired orthosis.

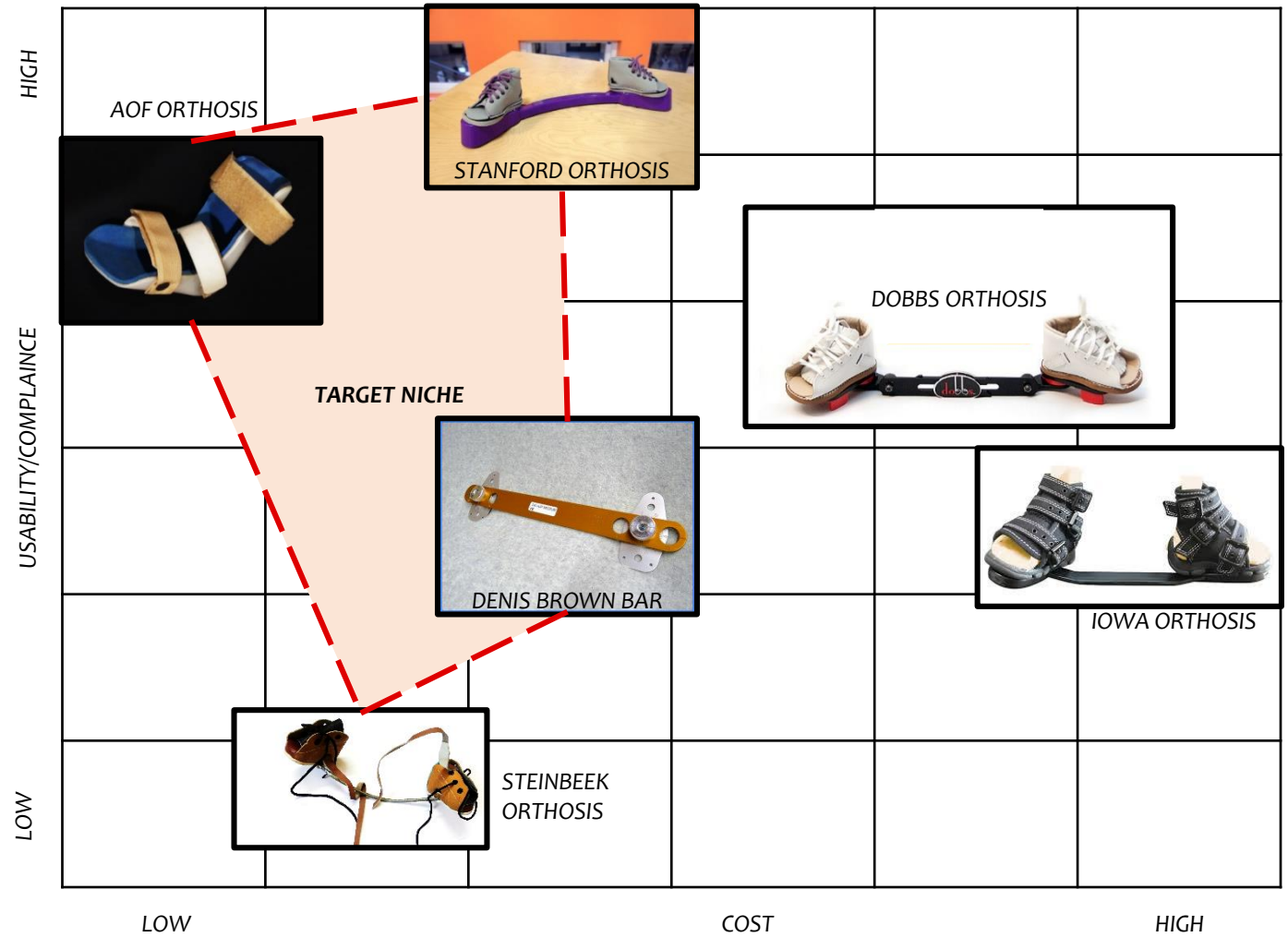

FIG. 4.14 PRODUCT POSITIONING

Chapter 5

User-Product Interaction

Parent-Child Interaction



Fig. 5.1 CLUB FOOT CLINIC AT B J WADI HOSPITAL

Another round of visiting and meeting Users was conducted, during the User study at B J WADIA hospital, focused at the parents child interaction during:

- *Travelling*
- *Feeding the child*
- *Playing*
- *How they manage to put child to sleep*

USER 5

CLINIC – Clubfoot clinic at B J WADIA Hospital

CLINICIAN – Dr Alaric Arijoo, Dr Bhushan

LOCATION – Parel

AGE – 1.5 years

CONDITION – Bilateral Clubfoot



FIG. 5.2



FIG. 5.3



FIG. 5.4



FIG. 5.5



FIG. 5.6

- The father used to carry child during in Local trains and for walks in busy places as shown in the figure 5.2
- At home and for walks around their home he would hold the child as shown in figure 5.3
- For any instance, if the baby needs to be made standing for short span of time around 10 minutes, then he was made to stand like as shown in figure 5.4
- The mother of the child used to carry him as shown in figure 5.5.
- The kid used to play sitting sometimes and was made to sit while feeding as shown in figure 5.6.



FIG. 5.7



FIG. 5.8



FIG. 5.9



FIG. 5.10

- The father reported of child observing the shoelace while they put on to his foot as shown in the figure 5.7
- The parent , both, use to assist each other to brace the child as shown in figure 5.8 and 5.9
- The father told that he used to be fascinated with the bright blue lace and tries to access them as shown in figure 5.10
- The kid used to play sitting with his other toys interacting with brace bar as shown in figure 5.11 and 5.12



FIG. 5.11



FIG. 5.12

USER 6

CLINIC – Clubfoot clinic at B J WADIA Hospital

CLINICIAN – Dr Alaric Arijoo, Dr Bhushan

LOCATION – Parel

AGE – 1.5 years

CONDITION – Bilateral Clubfoot



FIG. 5.13



FIG. 5.14



FIG. 5.15

- The mother use to feed and play with the child as shown in the figure 5.13
- She would talk him to small walks and out to sleep as shown in figure 5.14
- For any instance requiring for the child to stand, grand mother would assist and hold him as shown in figure 5.15



FIG. 5.16



FIG. 5.17

The was fond of playing by sitting as shown in the figure 5.16 and 5.17 . He played most with colored objects as per his Mother. He was curiously observing the brochure given to him.



FIG. 5.18



FIG. 5.19



FIG. 5.20



FIG. 5.21



FIG. 5.22

- The child used to cry a lot while being braced. The mother tries to put shoe on left foot as shown in the figure 5.2
- The mother always needed assistance from her mother-in-law for bracing the child as shown in figure 5.19 and 5.20
- The child was made to stand if required as shown in figure 5.21
- The kid suffered some skin infection over the ankle because of old circulated brace, as shown in figure 5.22.

USER 7

CLINIC – Clubfoot clinic at B J WADIA Hospital

CLINICIAN – Dr Alaric Arijoos, Dr Bhushan

LOCATION – Parel

AGE – 1.5 years

CONDITION – Bilateral Clubfoot

- The child was visited to clinic by his Mother.
- The kid used to play sitting as shown in figure 5.23.
- The mother used to put him to sleep and fed the baby in her lap as shown in figure 5.25
- The mother of the child used to carry him while walking as shown in figure 5.24.



FIG. 5.23



FIG. 5.24



FIG. 5.25

USER 3

CLINIC – Clubfoot clinic at B J WADIA Hospital

CLINICIAN – Dr Alaric Arijoos, Dr Bhushan

LOCATION – Parel

AGE – 2.5 yrs. Old

CONDITION – Bilateral clubfoot



FIG. 5.26



FIG. 5.27



FIG. 5.28

- The child was visited to clinic by his father.
- The father report that, they made child sit on small stool during feeding, playing and putting brace as shown in figure 5.26 and 5.27.
- The child was made to stand as shown in figure 5.29 if required.
- The father did the lacing in a different way, as shown in figure 5.28, to make sure that it is tighter.



FIG. 5.29

USER 7

CLINIC – Clubfoot clinic at B J WADIA Hospital

DESIGNATION– Cure NGO Worker

LOCATION – Parel

- There is a NGO Desk run by Cure NGO, which works for the facilitating the treatment to unprivileged people at B J Wadia Hospital and collaborates with the Miracle feet Organization for free distribution of clubfoot orthosis to the patients visiting B J Wadia Hospital.
- One of the desk member is responsible to allot orthosis to the patients depending upon their stage of treatment, progress and most importantly the fit/size of the shoe.
- The NGO circulates steinbeek orthosis among the patients as shown in figure 5.5 and the angle setting is done manual by this worker by bending the metallic rod around the table corner as shown in figure 5.6



FIG. 5.30



FIG. 5.31



FIG. 5.32

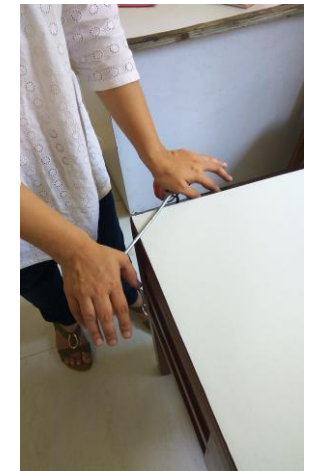

FIG. 5.33

Anthropometric considerations

Figure 5.34 show a comparative study of available data for an average height of an adult and the child, performed to identify the possibilities of how differently the brace can make contact on parents body or any one carrying a braced baby.

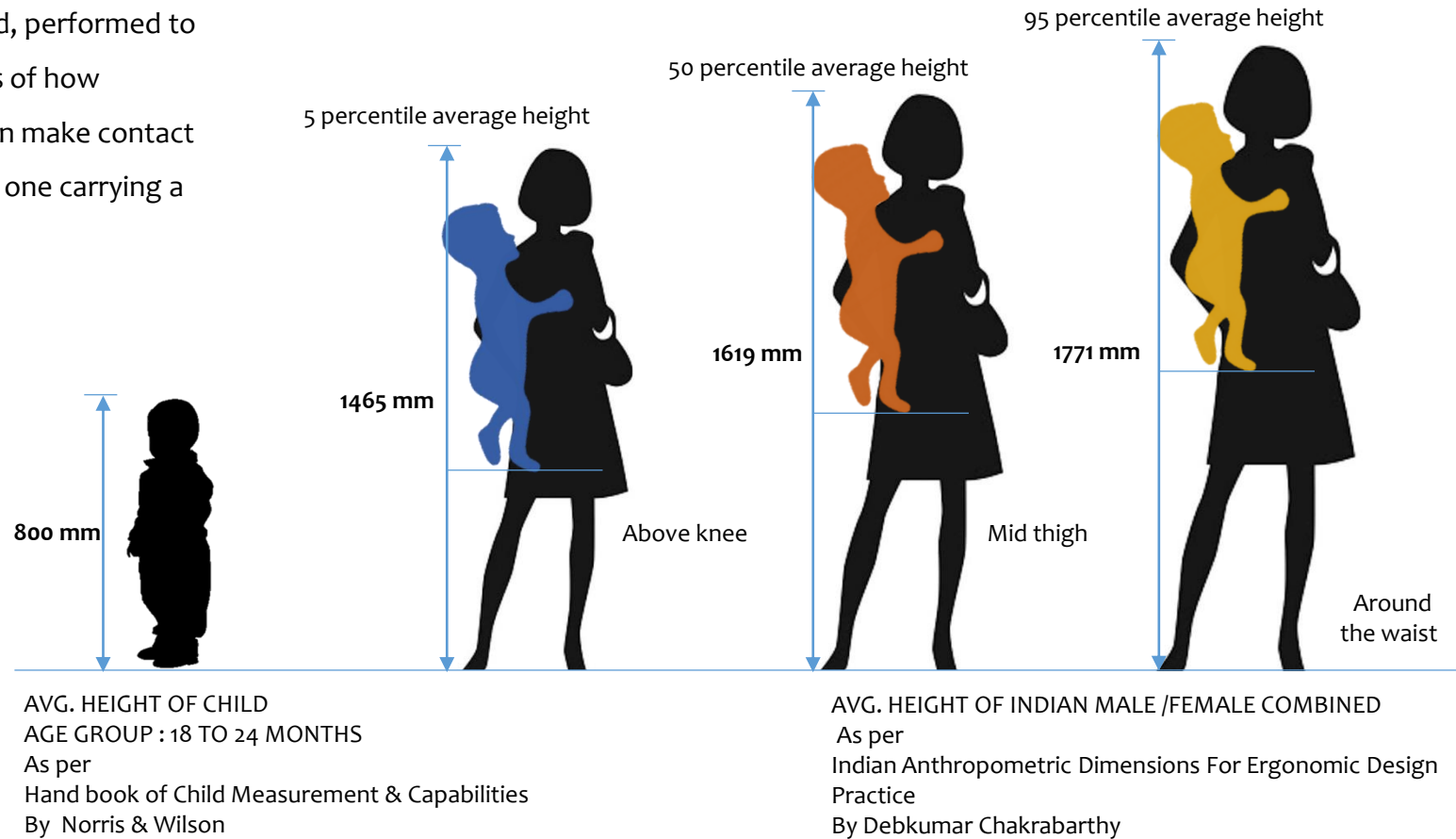

FIG. 5.34 POINT OF CONTACT OF BRACE WITH THE BODY

Ergonomics of Bracing

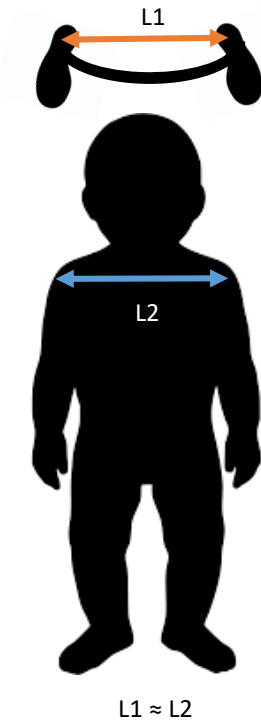

FIG. 5.35 BRACE LENGTH NORM

Brace size

The size of the brace is specified by its distance between the centre of rotation of the feet. This distance should approximately equal the shoulder breadth of the child as specified by the Doctors.

The sizes suggested by the Doctors are:

- 180 mm for age below 2 yrs.
- And 220 mm age above 2 yrs.

Center of rotation of foot

The figure 5.36 shows the approximate division of foot length into three equal parts such that the line of load passes through the distance of one-third of foot length from towards the hind foot. This is a standard data used in Transtibial Prosthetics Engineering [as per the reference 26]

This data was consider for referring to the center of rotation for foot abduction angle adjustment on the sole.

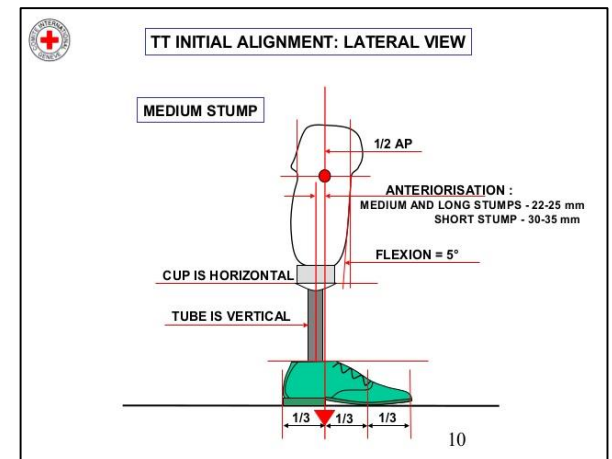

FIG. 5.36 THE CENTER OF ROTATION OF FOOT

Key Insights

- A closed Orthosis (shoe) makes it difficult to know the foot position within the shoe.
- Over-lacing the shoe creates discomfort to Child & Parents together.
- Most Parents lacks the idea of how exactly they followed the given instruction.
- Most clinically popular Orthosis lacks compliance with the Users.

Chapter 6

Proof of Concept

Biomedical Engineering and Technology (Incubation) Center Lab, IIT Bombay, has developed the technology supporting the need for monitoring of usage of brace and data collection. Figure 6.1 shows the schematic of circuit.

As per the schematic:

- There are piezo sensors placed in the shoe-sole.
- The bottom of the sole has a contact point to transfer signal from sensor to PCB module located at one end of the Brace.
- There is a power supply [Lipo battery] located on other side of the brace.
- The PCB module hubs a slot for the Micro SD card, used for data collection.
- The shoe when attached on the brace, the contact points on shoe and brace respectively, should always maintain contact with each other for proper data collection.

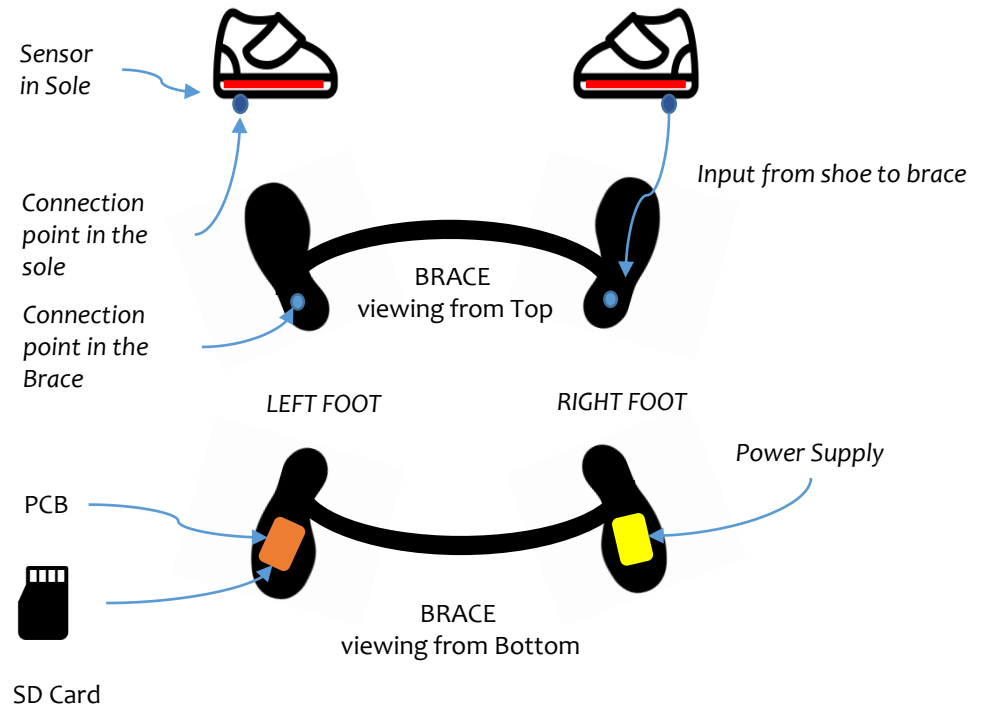
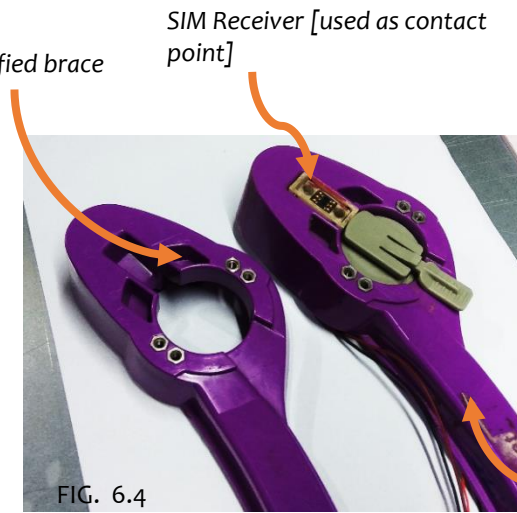

FIG. 6.1 CIRCUIT SCHEMATIC

Proof of Concept

- The circuitry was installed on a Stanford brace to demonstrate and conduct trial.
- The FSR sensors, as shown in figure 6.2, are put into shoe sole, the sensors are connected to main circuit running through the brace.
- The input from sensor is translated through the contact points, as shown in figure 6.3, below the shoe sole to the SIM receiver attached on the brace as shown in figure 6.4.
- The data is stored in the Micro SD card in Micro Data Logger and the whole circuit is powered by a Lipo Battery as shown in figure 6.5.



Lipo Battery

Dimensions:
35 x 17 x 5mm

Spécification:
3.7 v 600 mAh

Micro Data Logger For SD Card

Dimensions:
35 x 35 x 5mm

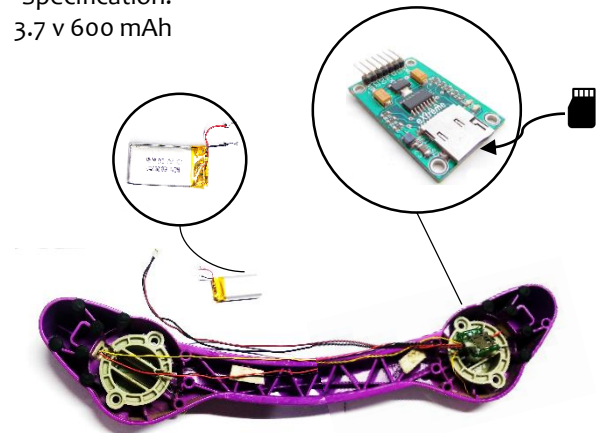

Modified brace

FIG. 6.5

Present procedure [*Scenario*]

- When the child is brought to clinic, he/she is allotted with a steinbeek or Stanford brace depending upon his/her condition.
- In the next visit, the parents will have to report the conduct of bracing, prescribed in previous appointment.
- Sometimes, the reporting of follow up by parents is not reliable as per clinicians, due to which the given treatment can prove to be false/incorrect. This is more prominent in case were the child may not show any improvement with respect what parents are reporting.
- The child is subjected to change of size of brace and shoe depending upon the his/her progress.

Expected procedure after adopting the technology

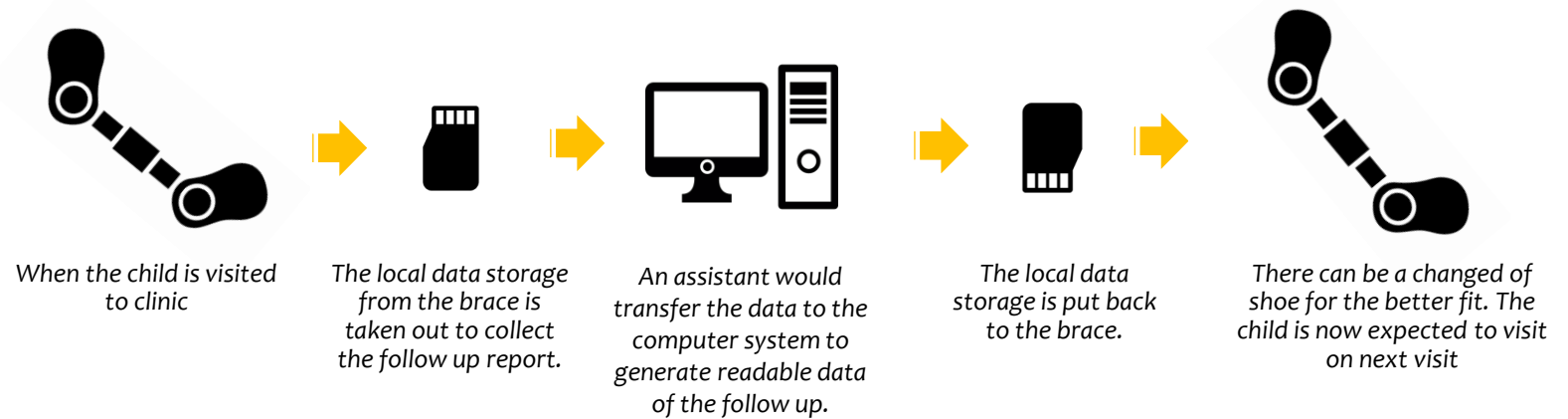

Bracing Protocol

In a meeting with Dr. Suresh Chand at B J Wadia Hospital, the bracing protocol was explained as

- The shoes are put first
- And then the brace is put on the shoes
- The step between the angle of abduction should be equal to or more than 20 degrees and the angle of dorsiflexion can maintain between 10 to 15 degrees.

Chapter 7

Design Brief

Design statement

To design a Club-foot Abduction Orthosis for Better User Compliance and True Monitoring of Prescribed Usage.

Design Brief

FUNCTIONAL REQUIREMENTS

UNOBSTRUSIVE

No electrical circuitry component should be visible

LIGHT IN WEIGHT

Not more than 500 mgs

DATA COLLECTION

Should facilitate realistic data collection

SAFETY

The orthosis should be water proof & electrical shock proof

USER COMFORT

The orthosis should be easy to adapt by child & during mother child interaction

COST EFFECTIVE

The cost should not be more than \$ 25

TARGET USER

PRIMARY USER

Child

SECONDARY USER

Parents/ Guardian

TERTIARY USER

Clinicians and NGO staff

MAINTAINANCE

BATTERY REPLACEMENT

Every 3 months

By clinicians

EASE OF CLEANING

the orthosis should be easy to clean of particulate and fluid dirt

USAGE PATTERN

INITIALLY

Braces to be used 23 hrs. a day (for first 4 months)

REGULAR

Then 12 hrs. a day (for next 3-4years)

MAY HAVESs

Provision of Child-brace interaction.

Chapter 8

Ideation

MINDMAP

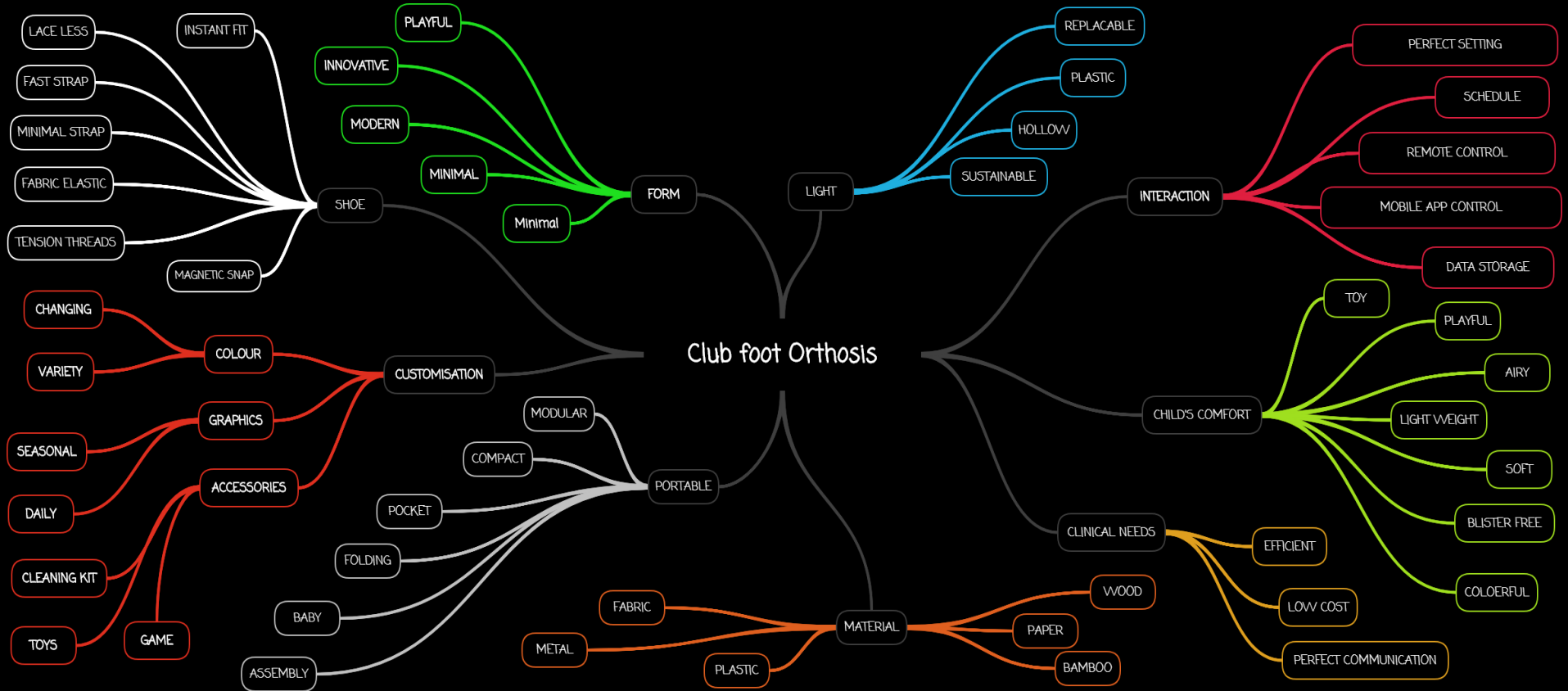

Ideations for Brace

GROUP 1- FRUGAL MANUFACTURING

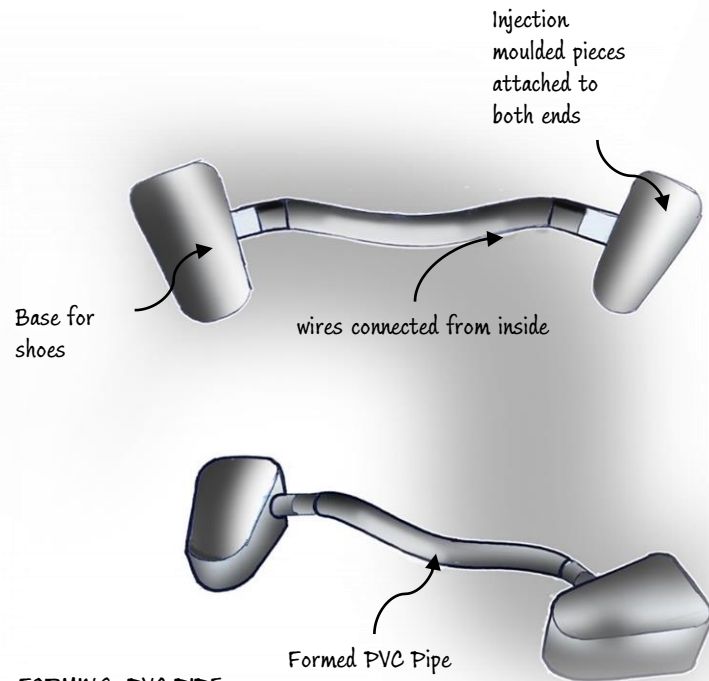

KEYWORDS : FORMING, PVC PIPE

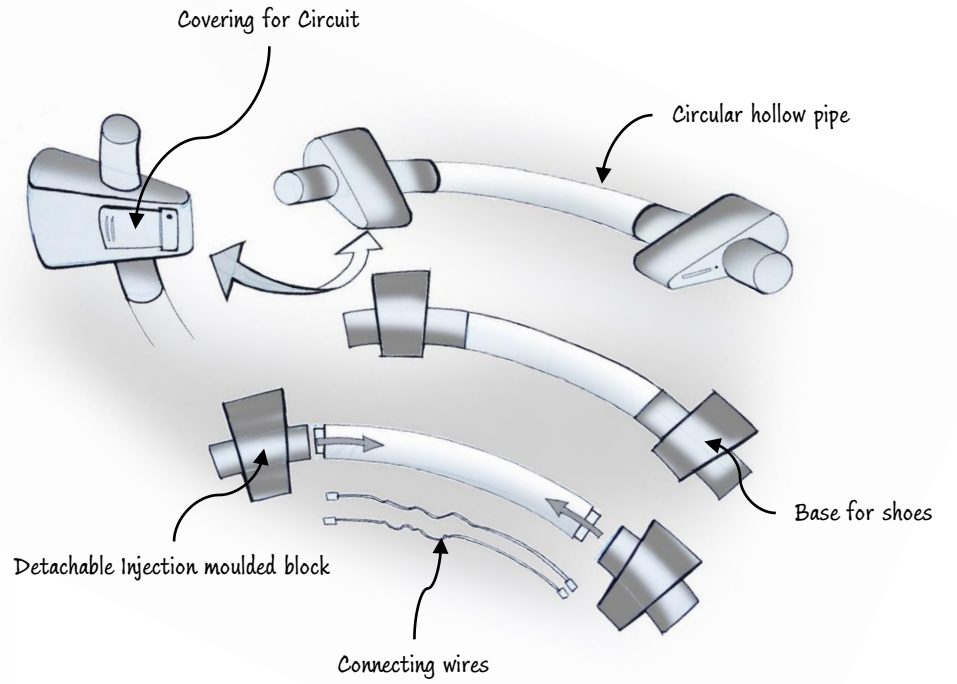

KEYWORDS :
FORMING, PVC PIPE, DETACHMENT

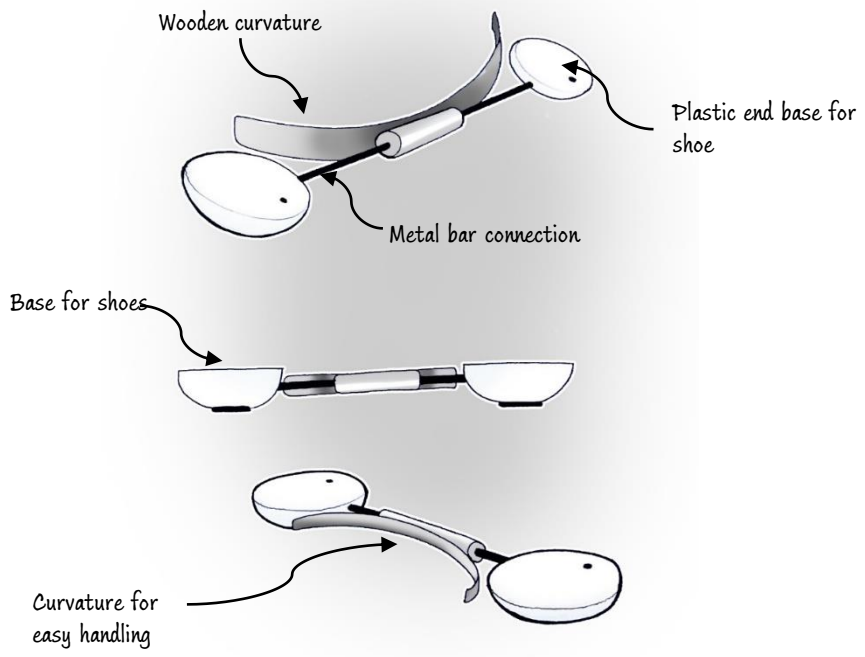

KEYWORDS : SUSTAINABLE, ABUNDANCE, MATERIALS

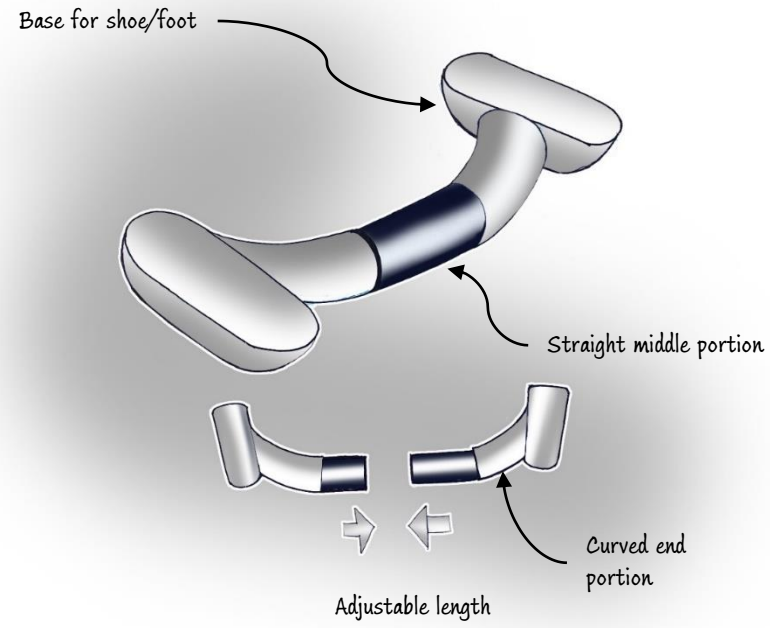

KEYWORDS : LENGTH ADJUSTMENT

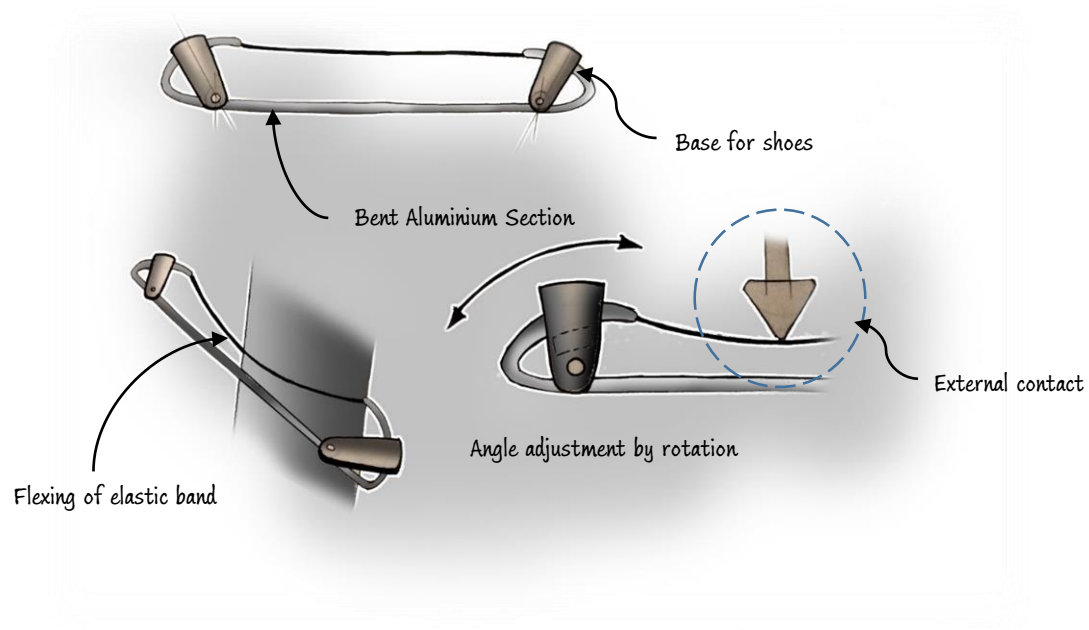

KEYWORDS :
EXTRUSION, BENDING, LIGHT, STRONG

GROUP 2- INTEGRAL BODY

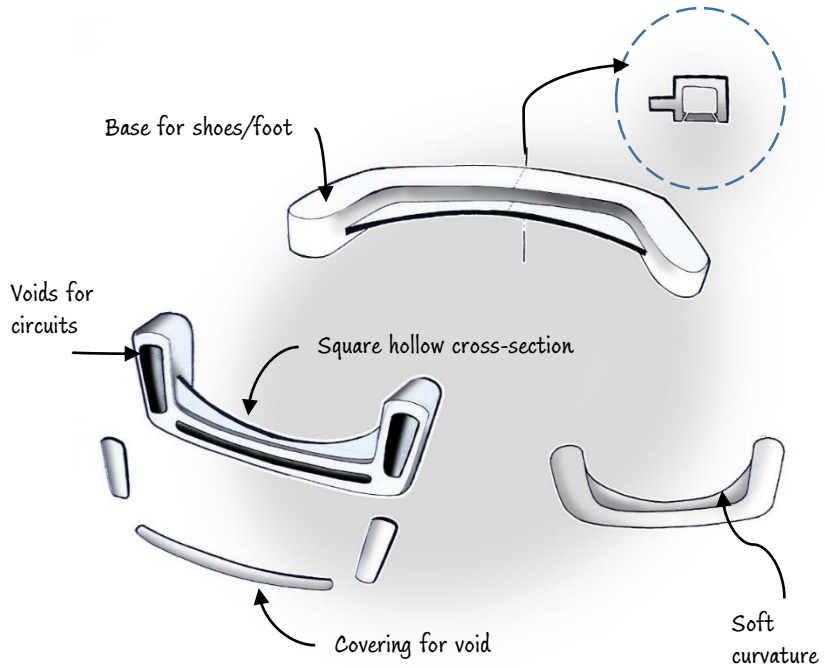

KEYWORDS : RIGID, UNIBODY

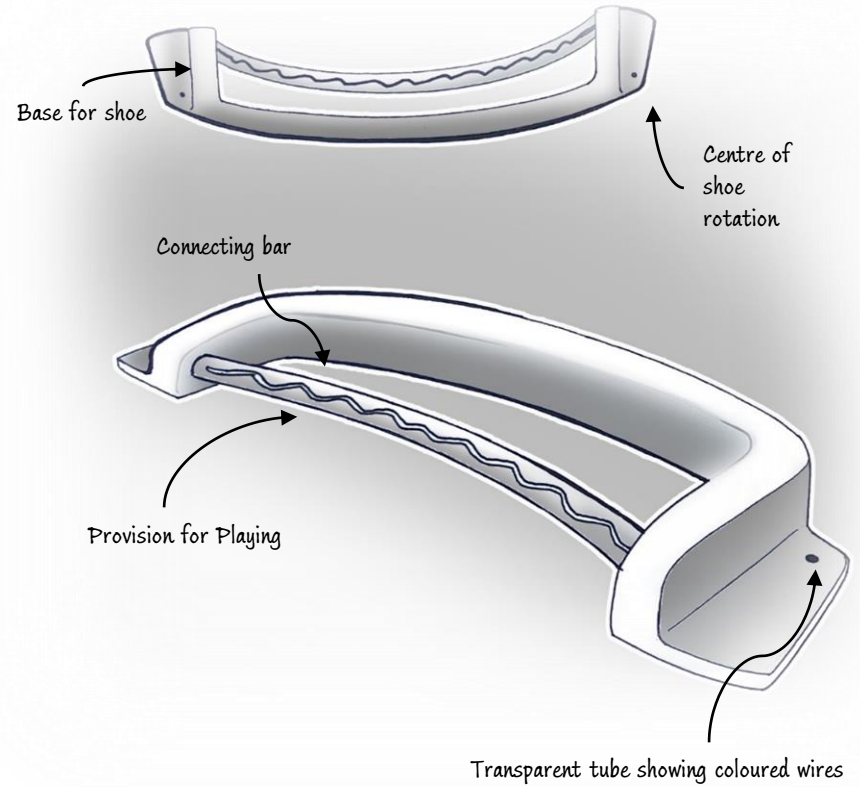

KEYWORDS :
SURPRISE, TRANSPERANT, COIL, PEDAL

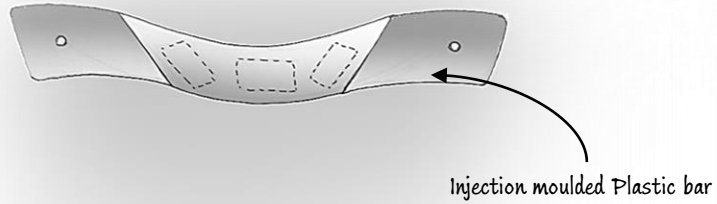

Base for shoe

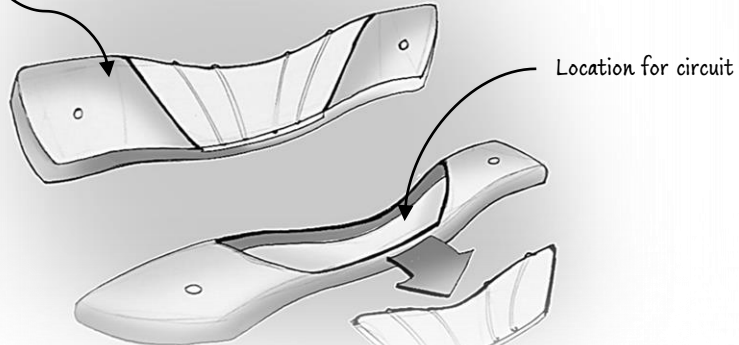

Lid to access/conceal circuit

KEYWORDS :
UNIBODY, COMPACT SOFT, CLARITY

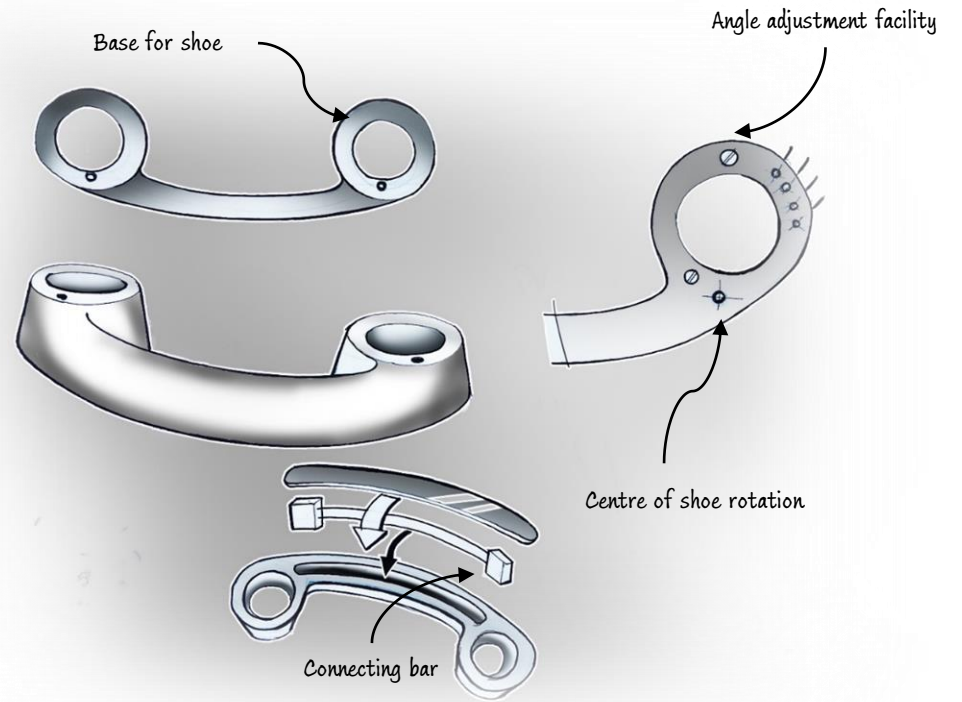

KEYWORDS :
HOLLOW, SOFT, TELEPHONE

GROUP 3- ADDED FUNCTIONALITY

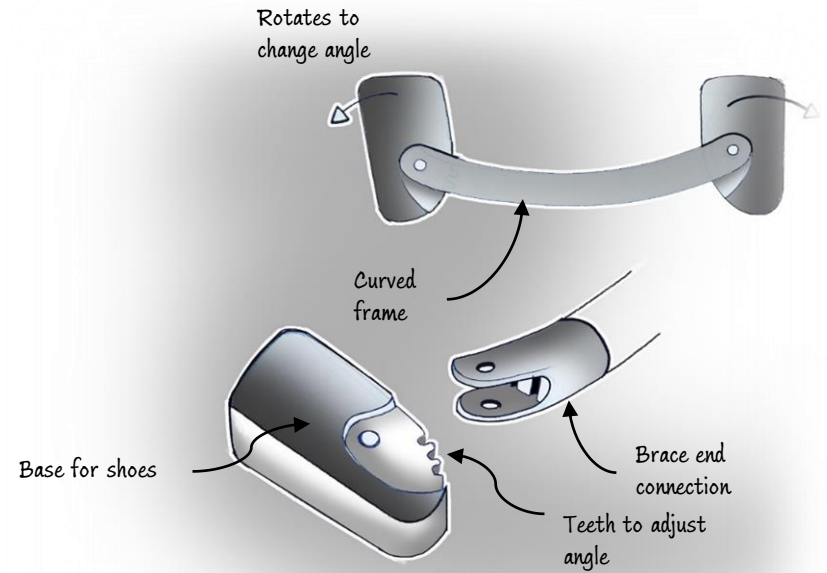
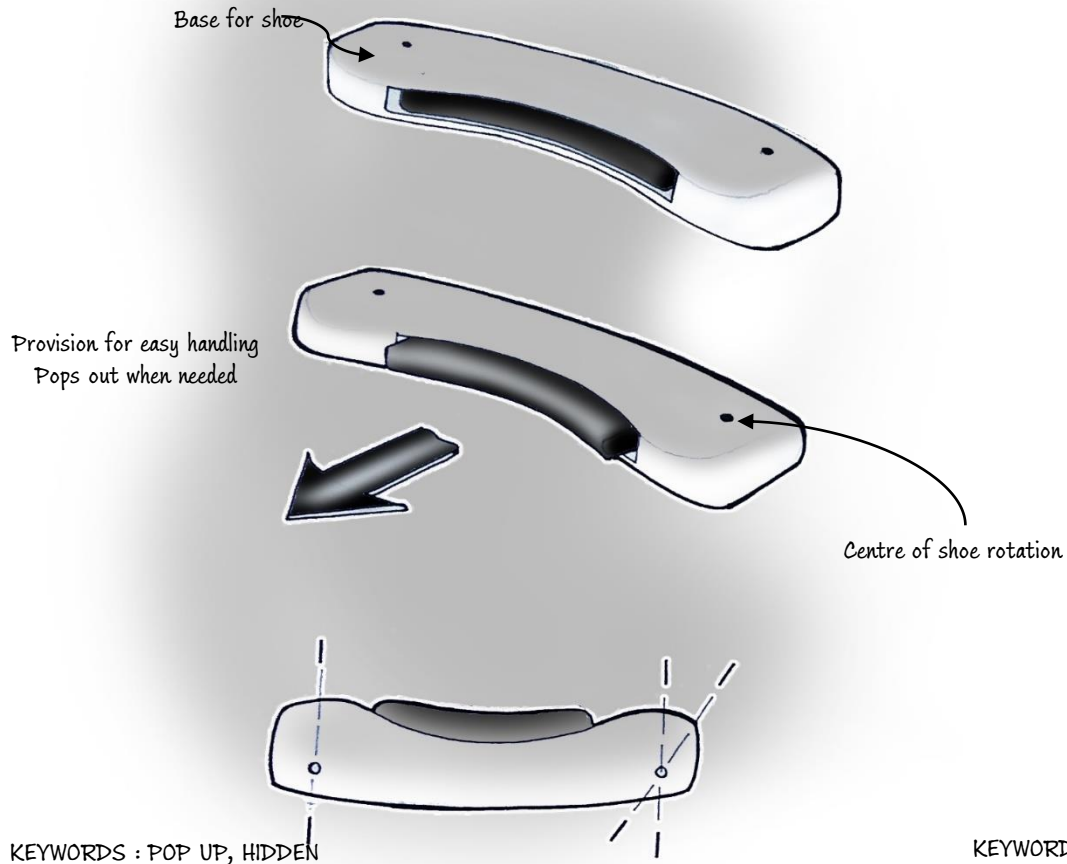

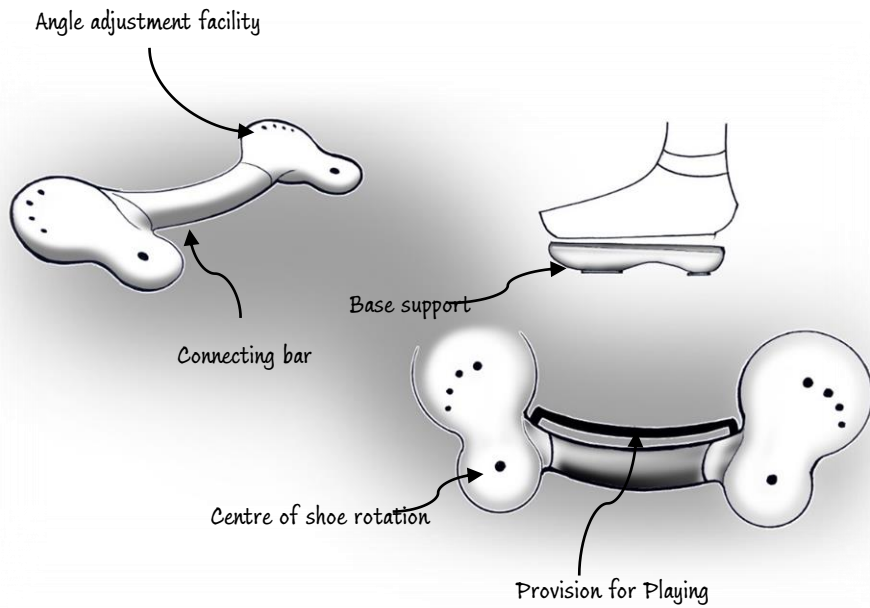

KEYWORDS : BONE, CONNECTION, STRENGTH, LINK

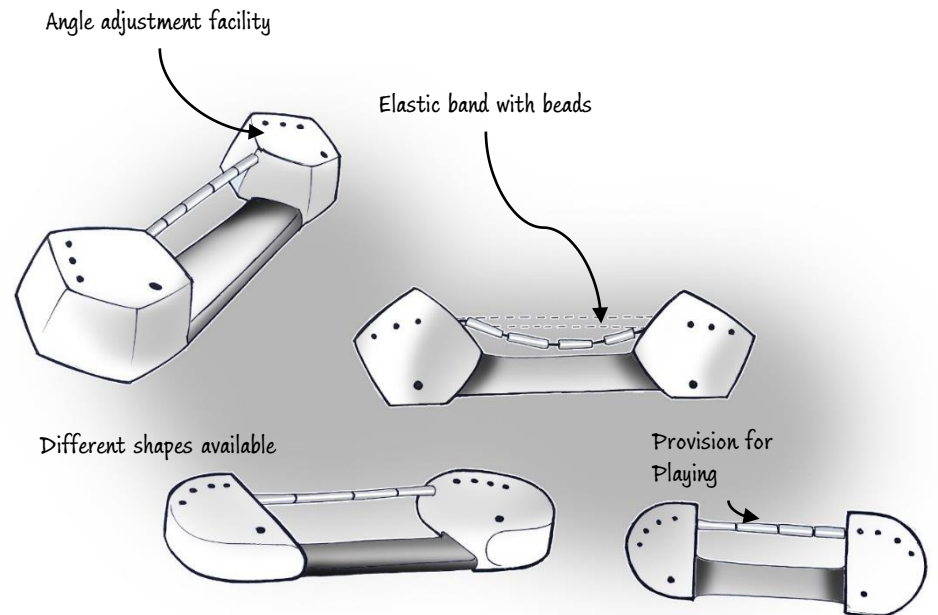

KEYWORDS : PLAY, SHAPE, ATTRACTIVE

Ideations
For accessories

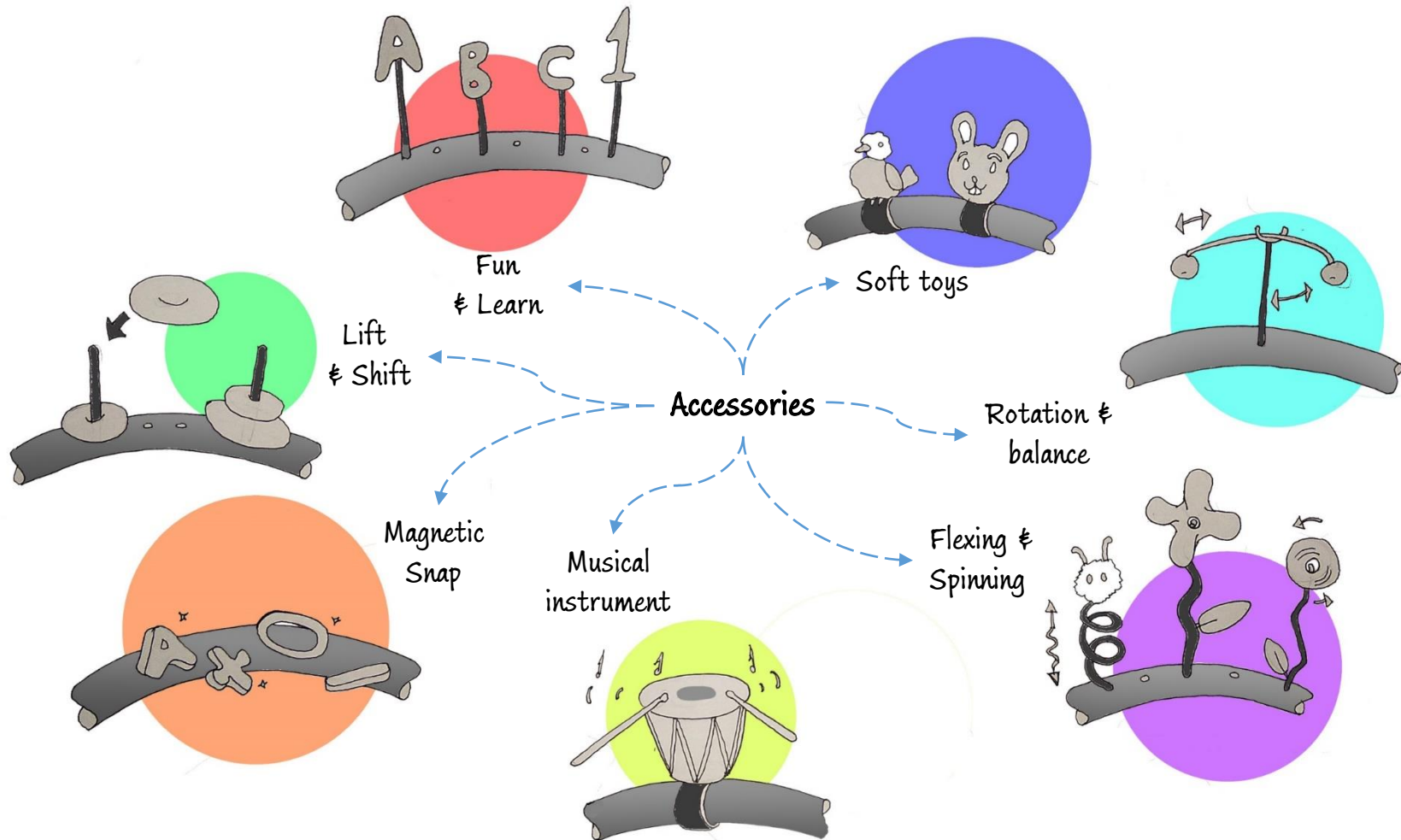

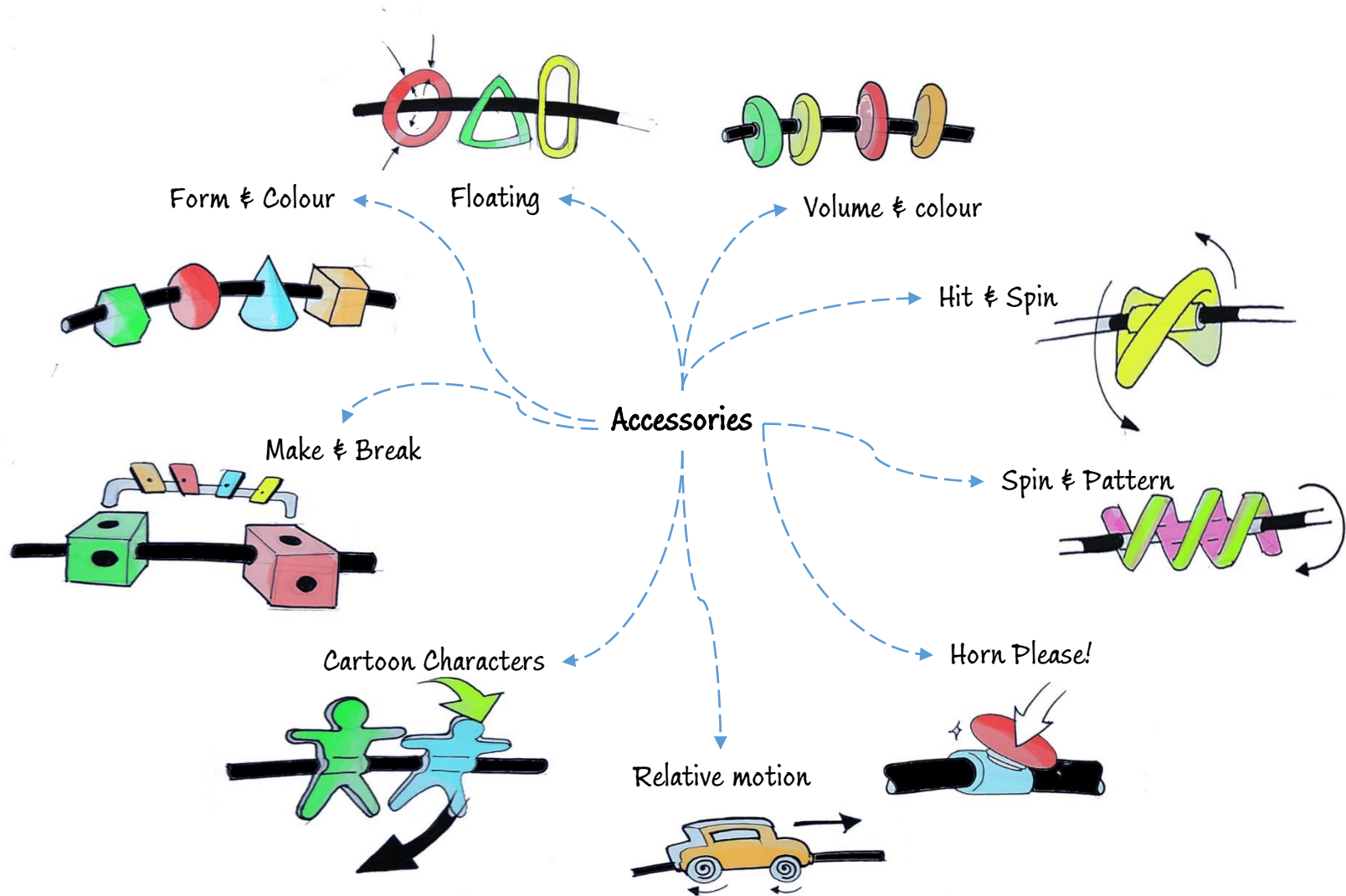

Chapter 9

Design of Brace footwear

Locating the Foot

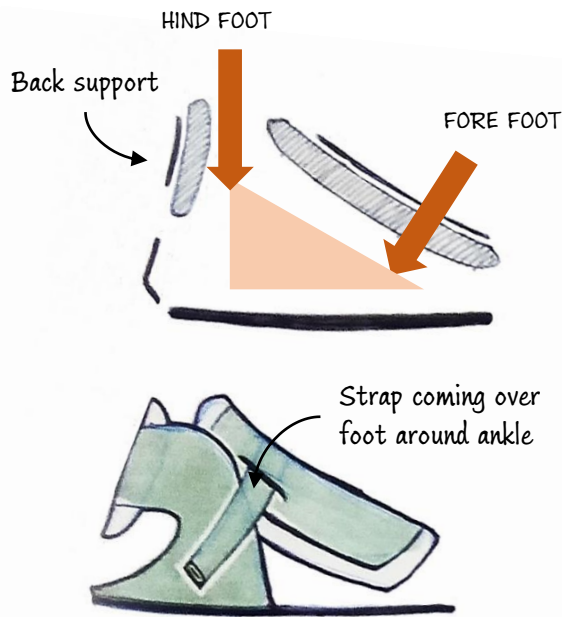

FIG. 9.1 REQUIRED FASTENING FOR FOOT

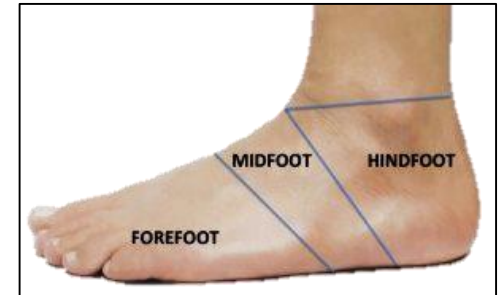

FIG. 9.2 FOOT DIVISION

- One of the key considerations for designing the foot wear for orthosis was to locate the foot properly.
- From the study of other orthosis and discussions with clinicians, it was found that, the foot needs to be located on the sole such that the hind foot and the fore foot as indicated in figure 9.2, should make firm contact on the sole.
- To assign a controlling detail to the foot wear, the least required no. of fastening forces/tension should strap the foot about the hind and fore portions as indicated in figure 9.1.

Ways to Strap

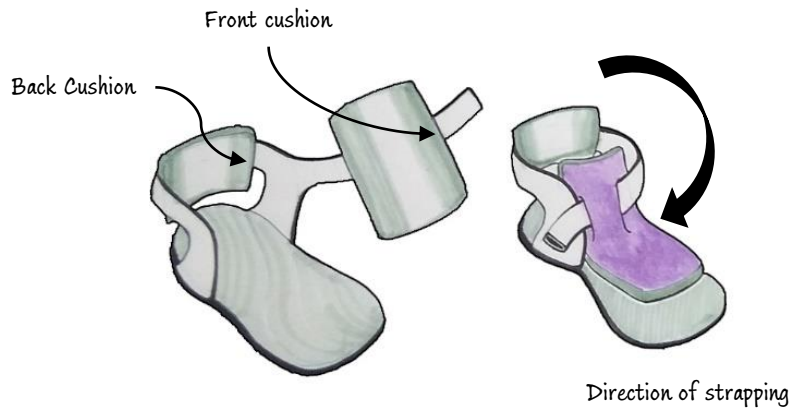

FIG. 9.3

Adding to the strapping further, the major two stress points; first, where the tightening makes mark on the foot as found from user study, two cushioning was required. One for front and other for back side as shown in figure 9.3

Further, for fastening the strap, options like Velcro, lace, elastic band, buttons and buckles were considered, based on the present trends in shoe design, as shown in the figure 9.4,9.5,9.6 and 9.7 respectively.



FIG. 9.4 Velcro



FIG. 9.5 Lace



FIG. 9.6 Combination of Elastics & button

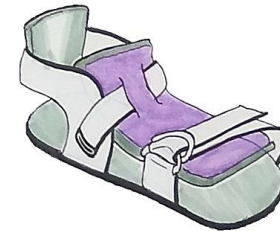

FIG. 9.7 Combination of Buckle with Velcro

Static anthropometry data for Leg & Foot
AGE GROUP 3 TO 4 YEARS

As per
SECTION 1.5
Hand book of Child Measurement & Capabilities
By **Norris & Wilson**

Indicated dimensions in figures 9.8 to 9.16 were taken into consideration for designing a footwear.
The age group 3-4 years was chosen initially.

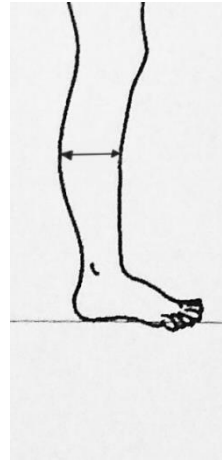

FIG. 9.8 Calf
Depth
6.5 cm

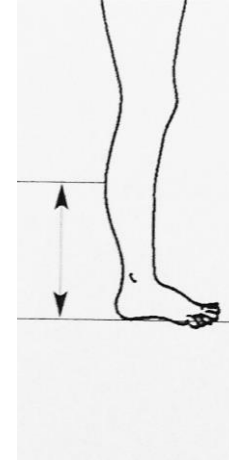

FIG. 9.9 Calf
height
18.6 cm

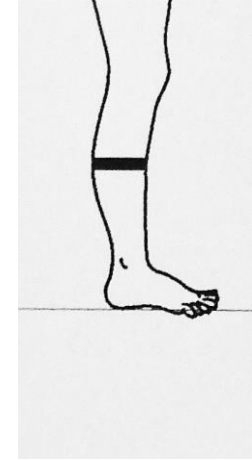

FIG. 9.10 Calf
circumference
20.6 cm

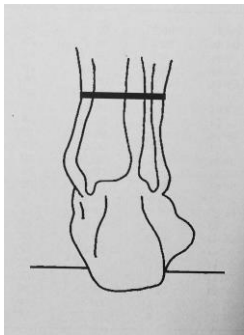

FIG. 9.11 Ankle
circumference
15.4 cm

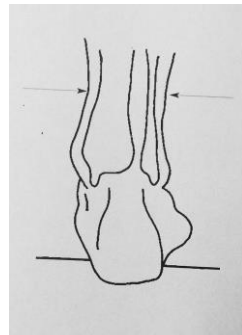

FIG. 9.12 Ankle
breadth
3.8 cm

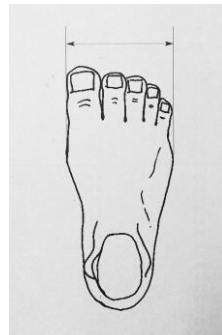

FIG. 9.13 Foot
breadth
6.8 cm

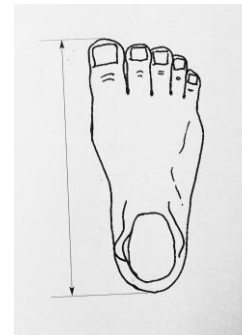

FIG. 9.14 Foot
length
15.5 cm

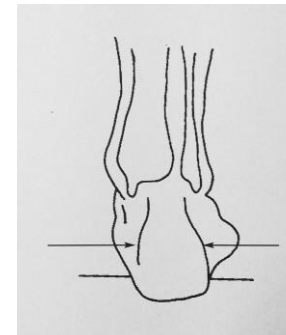

FIG. 9.15 Heel breadth
4.6 cm

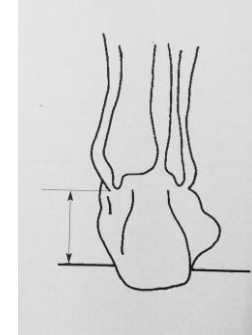

FIG. 9.16 Ankle
height
3.9 cm

Mock Up And Iterations



FIG. 9.17 MAKING OF MOCK-UP MODEL FOR A REFERENCE



FIG. 9.18 VELCRO



FIG. 9.19 COMBINATION OF ELASTICS & BUTTON



FIG. 9.20 LACE



FIG. 9.21 COMBINATION OF BUCKLE WITH VELCRO

As the figure 9.17 shows, a reference model was made to construct a synergetic strapping around it. Using which, four different mock ups, as shown in figure 9.18 to 9.21, were made to test the best suiting way to fasten the straps.

MODEL-Front strapping with Velcro



FIG. 9.22



FIG. 9.23



FIG. 9.24

MODEL-Front strapping with Buckle



FIG. 9.25



FIG. 9.26



FIG. 9.27

MODEL-Front strapping with Lace



FIG. 9.28



FIG. 9.29



FIG. 9.30

MODEL-Front strapping with Elastic band , Button & Velcro



FIG. 9.31



FIG. 9.32



FIG. 9.33

All the mocks were tested, as shown in above images, by kids of age group 3-4 years. The key insights from the testing were:

- Strapping with only Velcro was preferred by all parents [as children wore sandals for sports activities, parents were confident about using Velcro]
- Visual accessibility of foot and Inspection was easier with present way of strapping & flat sole.
- Wider front strap would be better.

Static anthropometry data for Leg & Foot
AGE GROUP 18 TO 24 MONTHS

As per
SECTION 1.5
Hand book of Child Measurement & Capabilities
By **Norris & Wilson**

The age group was later changed to 18 to 24 month considering the frequency of appointment and age of the patients visiting clinic.

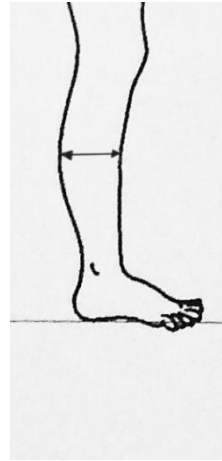

FIG. 9.34 Calf
Depth
6.2 cm

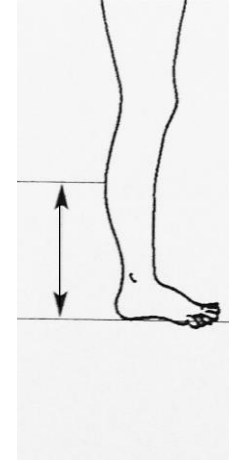

FIG. 9.35 Calf
height
16.8 cm

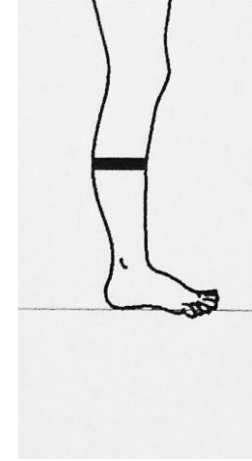

FIG. 9.36 Calf
circumference
19 cm

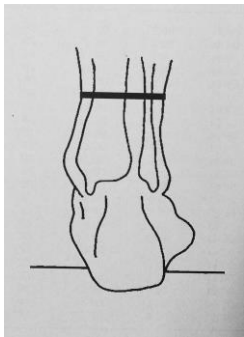

FIG. 9.37 Ankle
circumference
14.3 cm

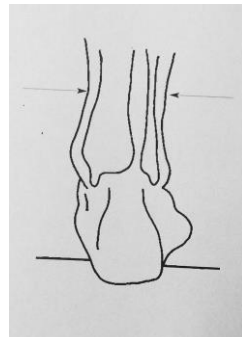

FIG. 9.38 Ankle
breadth
3.8 cm

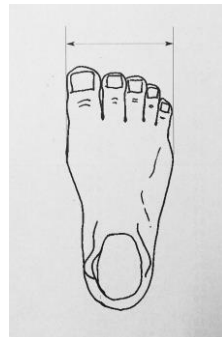

FIG. 9.39 Foot
breadth
5.5 cm

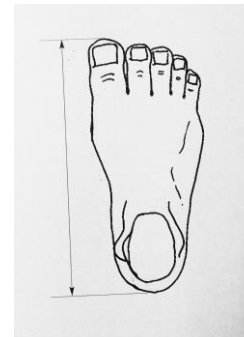

FIG. 9.40 Foot
length
12.5 cm

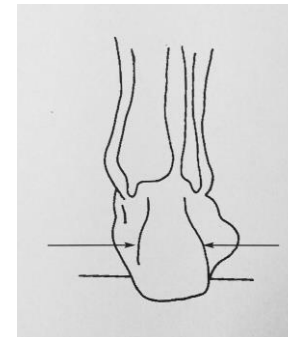

FIG. 9.41 Heel breadth
3.5 cm

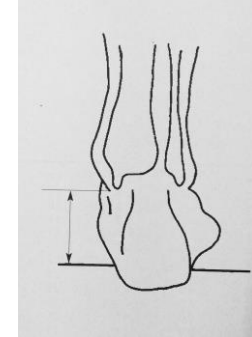

FIG. 9.42 Ankle
height
3.9 cm

Trial 1



FIG. 9.43



FIG. 9.44



FIG. 9.45



FIG. 9.46



FIG. 9.47



FIG. 9.48



FIG. 9.49

After the change in the target age group, another mocks up for foot were created to design the Velcro based foot wear. Figures above indicates the first trial.

Trial 2



FIG. 9.50



FIG. 9.51

Another trial [second], as shown in figure 9.50 and 9.51, with change of strapping direction was done. The strapping here comes from one side of the foot and turns back through an eye/loop for to be fasten by Velcro.

Trial 3

The initial trials were conducted considering that the whole foot wear can be constructed out of straps only for the ease of manufacturing as shown in figure 9.52 and figure 9.53 and 9.54 shows the trial 3.



FIG. 9.52



FIG. 9.53



FIG. 9.54

Trial 4



FIG. 9.55



FIG. 9.56



FIG. 9.57



FIG. 9.58



FIG. 9.59

Figure above shows another trial, where the width of Velcro band was different in straps. After this a feedback session was conducted, in which Dr. Sourabh Sinha and Dr. Suresh Chand from B J Wadia Hospital reviewed the work and the given feedback was-

- To keep the edge on the internal side of the foot straight and harder
- Increase the span of cushion from behind the heel.

Chapter 10

Design Concepts for Orthosis

Concept 1

Inspiration An Aluminium sections

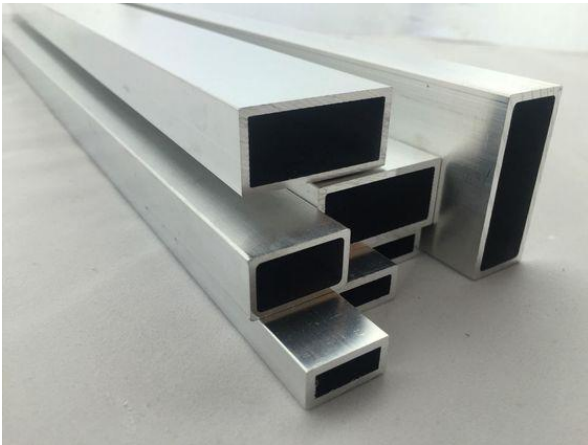

The idea was to use of aluminium's physical properties like light weight, ductility etc. to design a brace so that a minimal expression can be achieved with out loosing on the physical strength. The extrusion can be accompanied with the plastic bases to hub the electronics and the carry the footwear.

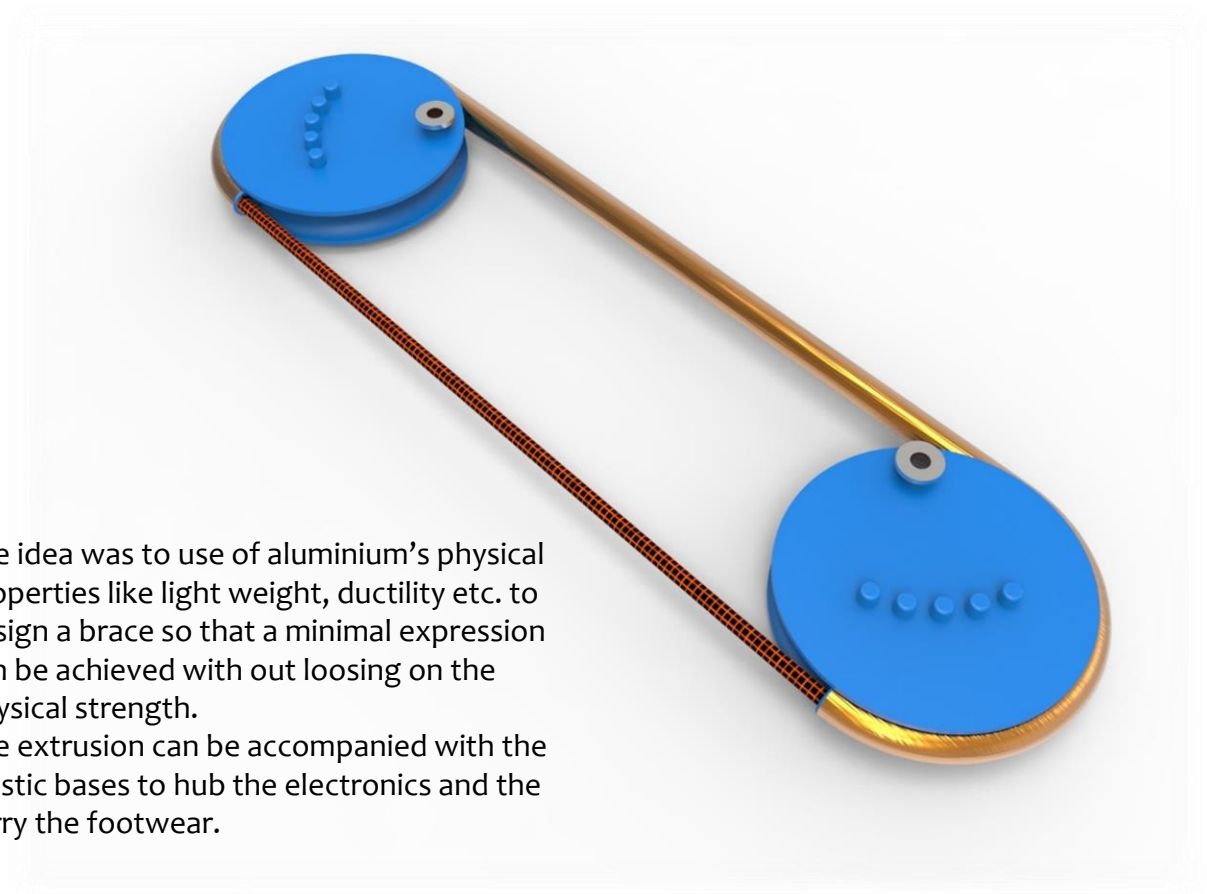

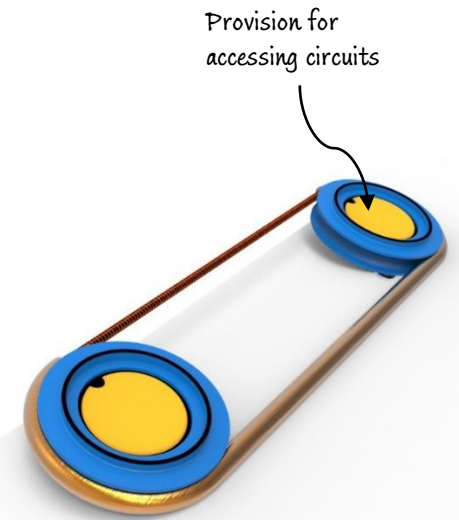
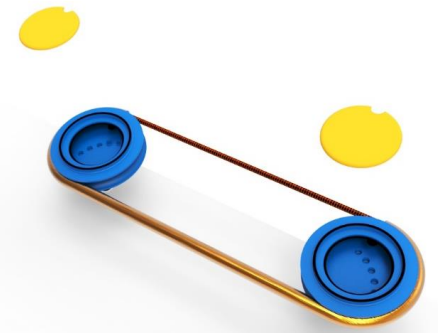
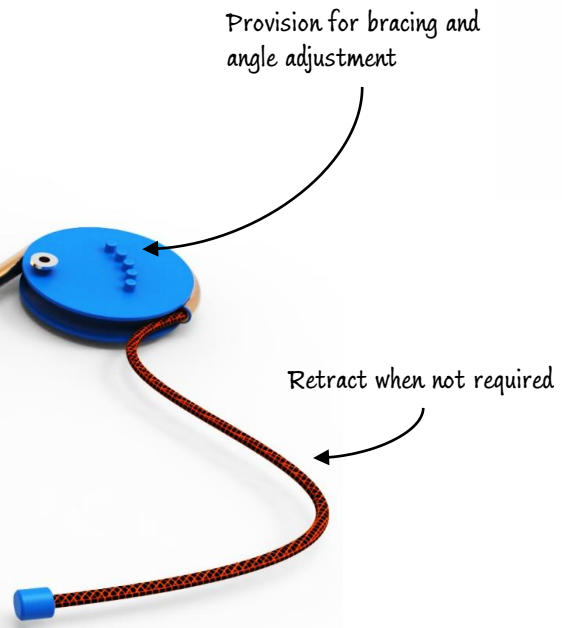
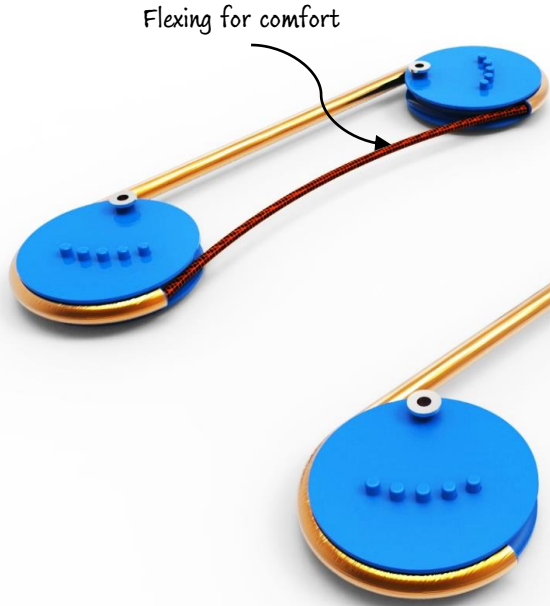

Concept 2



The idea was to create a uni-body structure inspired from the Bones. A uni-body structure like bone, retains better strength hence, the notion that *the brace is stronger as bones is validated by a simile.*

Also, the Bone as Object is quite popularly cartooned in many animated shows for children.

Inspiration A Bone



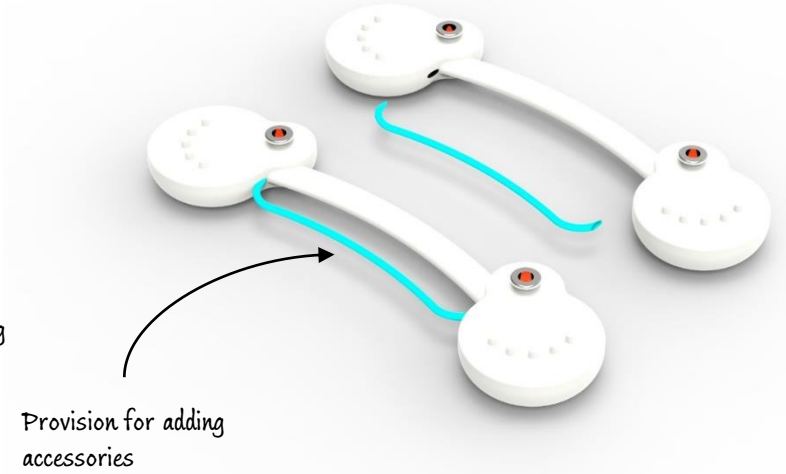
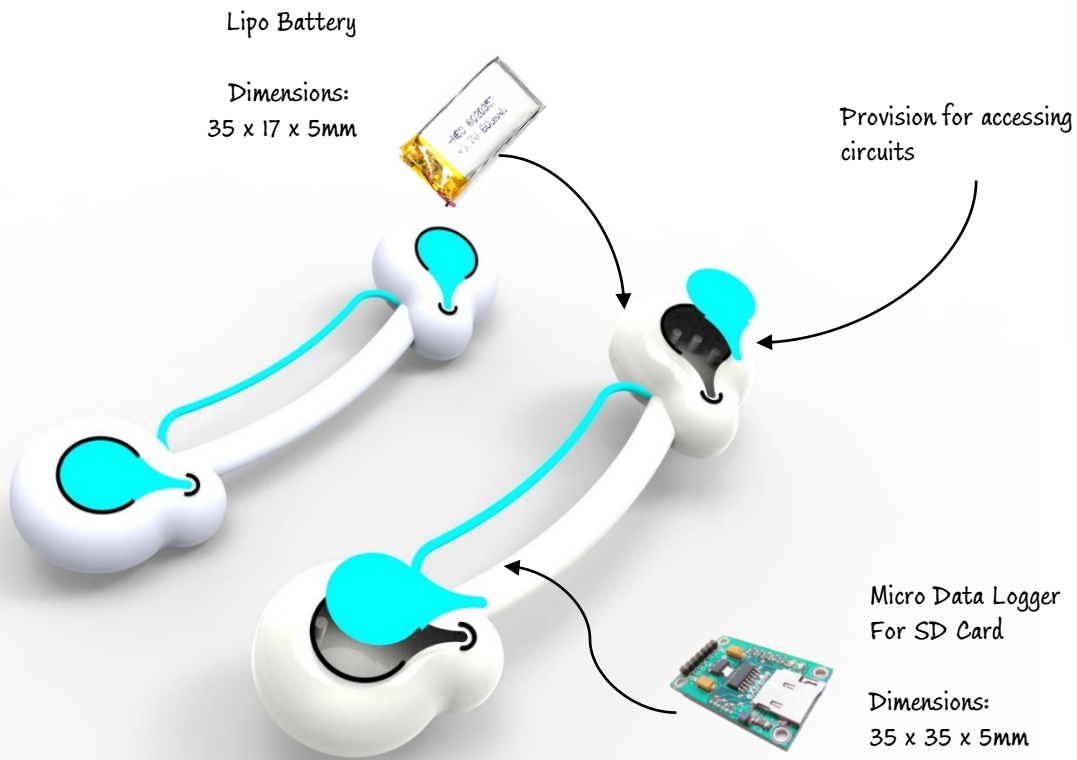

Concept 3

Inspiration The Lego block



The colorful and vibrant Lego blocks are popular for their structural flexibility of constructing almost anything out of strong and edgy blocks. The idea was to use this quality of Legos to bring in some customizability in brace.

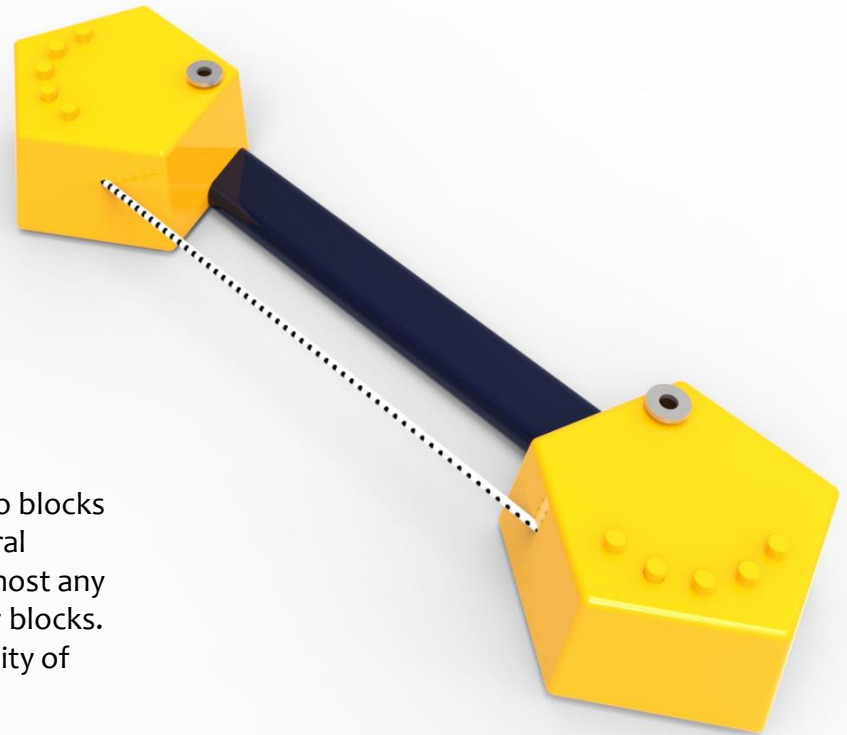

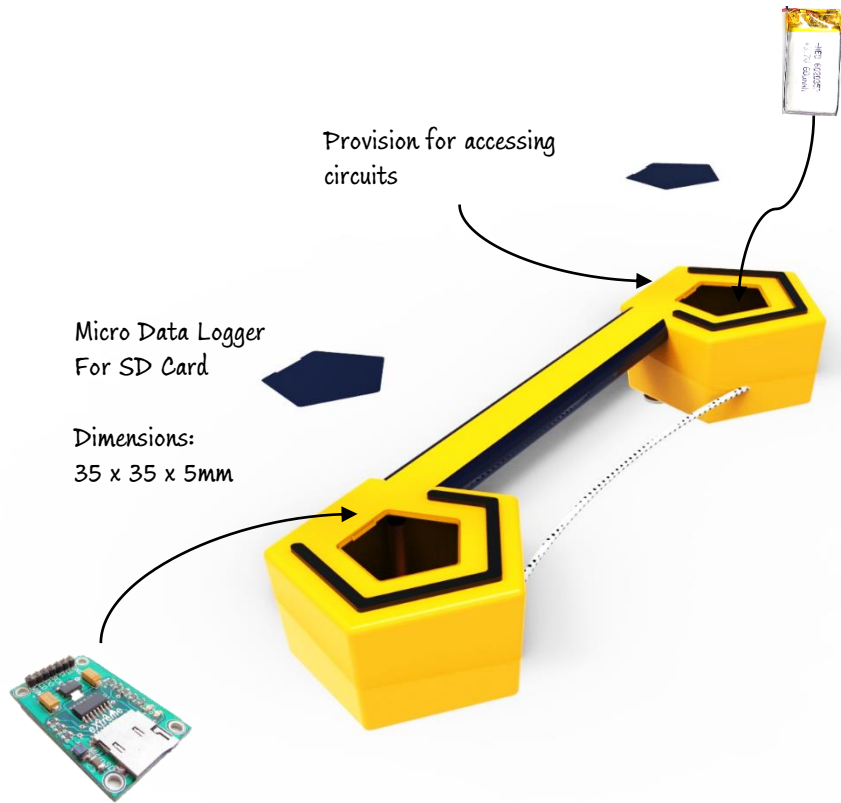

Lipo Battery

Dimensions:
35 x 17 x 5mm

Specification:
3.7 v 600 mAh

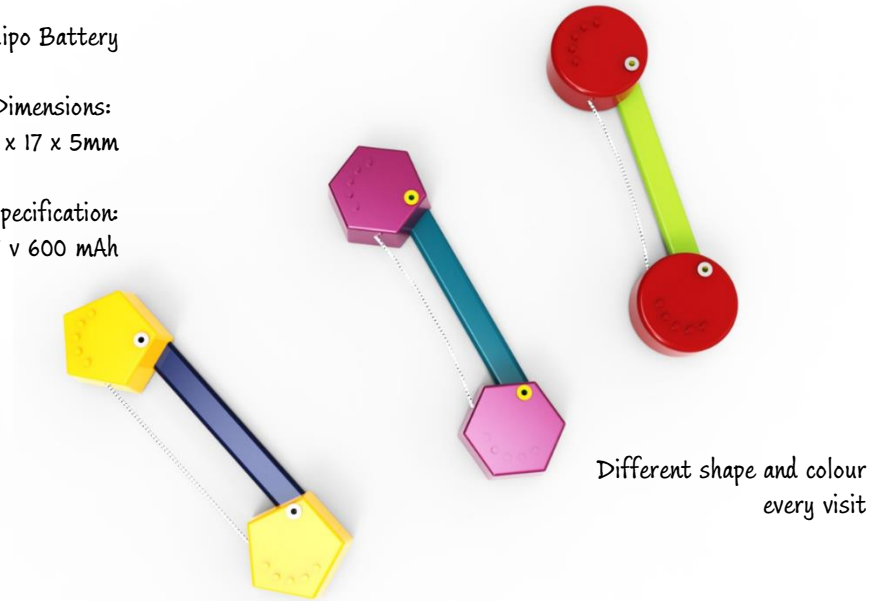

Flexing for comfort and mounting accessories

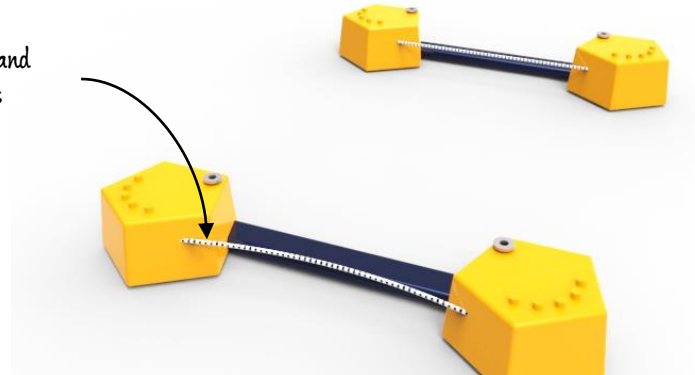

Concept 4

Inspiration
The Telephone toy



One of the most popular and imitated toy of all time- Telephone.
The idea was to bring in similar visual language to make it appeal like a just another toy to play around.



Lipo Battery

Dimensions:
35 x 17 x 5mm

Specification:
3.7 v 600 mAh



Micro Data Logger
For SD Card

Dimensions:
35 x 35 x 5mm

Hollow structure to add
strength



Provision for bracing and
angle adjustment



Provision for
accessing circuits

Chapter 11

Final Concept

Concept Analysis

	CONCEPT 1	CONCEPT 2	CONCEPT 3	CONCEPT 4
LIGHT WEIGHT	Using metal extrusion can increase the weight . Thinner sections would make it sonorous. Thicker section would make it heavier.	There is a functional distribution of volume that can help achieving lightest possible design with suitable grade of plastic.	The customization by use of basic geometric shapes calls for a bulkier ends of the brace.	The connection bar of the brace is biggest of all concepts making it consume more material to get manufactured and visually heavier
CUSTOMISATION	The flexing band and the anodizing of extrusion can be customized for color textures and patterns on them.	The subtle curved form can compliment physical well with a platform like attachment where the child can play and the brace can become more interactive.	This concept allows for customization of shape of the brace ends , color and flexing band for color, pattern, texture.	The color of the brace can be changed.
FORM FACTOR	The integrity of two different material creates a three piece configuration because of which it feels as though it lacks physical integrity	The form here is most functional of all the concepts.	The ideal of using shapes for inculcating customization into the brace would not necessarily come up with a good formal statement. This approach has randomness to it.	The intermediate connection is way stronger visually and overall the formal appeal is quite similar to the toys
MAINTENANCE	As this would be a three piece brace, cleaning would be an issue at joints	There is a possibility of accessing electronics from top. The defined shape and the mating with shoe can take care of the exposure of lid openings to foreign particles	There is a possibility that lids to access electronics can be shifted on the top. This would still can expose the openings to foreign particles because of undefined and bigger surface area.	The wide accessible cap at bottom can collect lot of dust and dirt.
SAFETY	Users would always be skeptical as metal extrusion will be carrying the connecting wires. Water proofing might fail at joints.	There is a defined bifurcation of space in this concept so it would help confining the circuit from any kind of leakage.	Like concept 2, this also has bifurcation of space but the addition of flexing band can permit moisture inside the brace body. There is a risk that it also might carry electric current if moist.	There is high risk of failing [of water proofing and electrical isolation] due large perimeter of the opening lid located at the bottom. This facilitates increased permeability for foreign particles

Concept Evaluation

Concept evaluation was done on the basis of functional requirement after a discussion with Dr. Sourabh Sinha.

Following are the factors considered :

- *LIGHT IN WEIGHT*
- *CUSTOMIZATION –color, shape, and attachments.*
- *SAFETY --water proof and electrical circuit isolation.*
- *FORM FACTOR*
- *MAINTENANCE --Ease of cleaning and accessibility of electronics*

Criterion	CONCEPT 1	CONCEPT 2	CONCEPT 3	CONCEPT 4
<i>LIGHT WEIGHT</i>	4	1	2	3
<i>CUSTOMISATION</i>	2	3	1	4
<i>SAFETY</i>	3	1	2	4
<i>FORM FACTOR</i>	4	1	3	2
<i>MAINTENANCE</i>	4	1	2	3
Average rank	3.4	1.4	2	3.2

Mood Boards

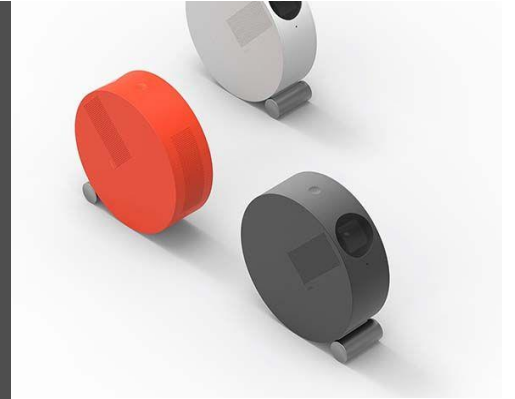

PLAYFUL

Mood board 1



SOFT

Mood board 2



MINIMAL

Mood board 3

Formal Exploration

Considering the parting of parts in plastic, provision of dorsiflexion, structural integrity, height of partition above the ground and expression from mood Boards some variations were done.

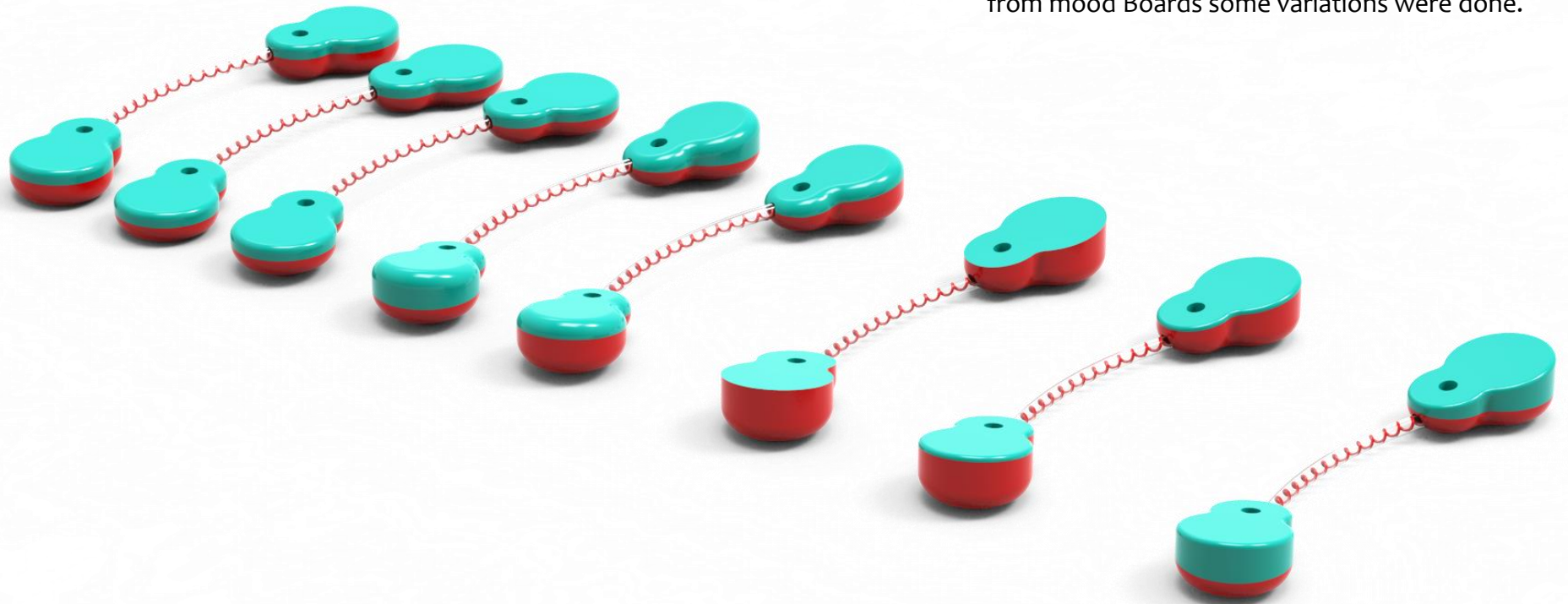

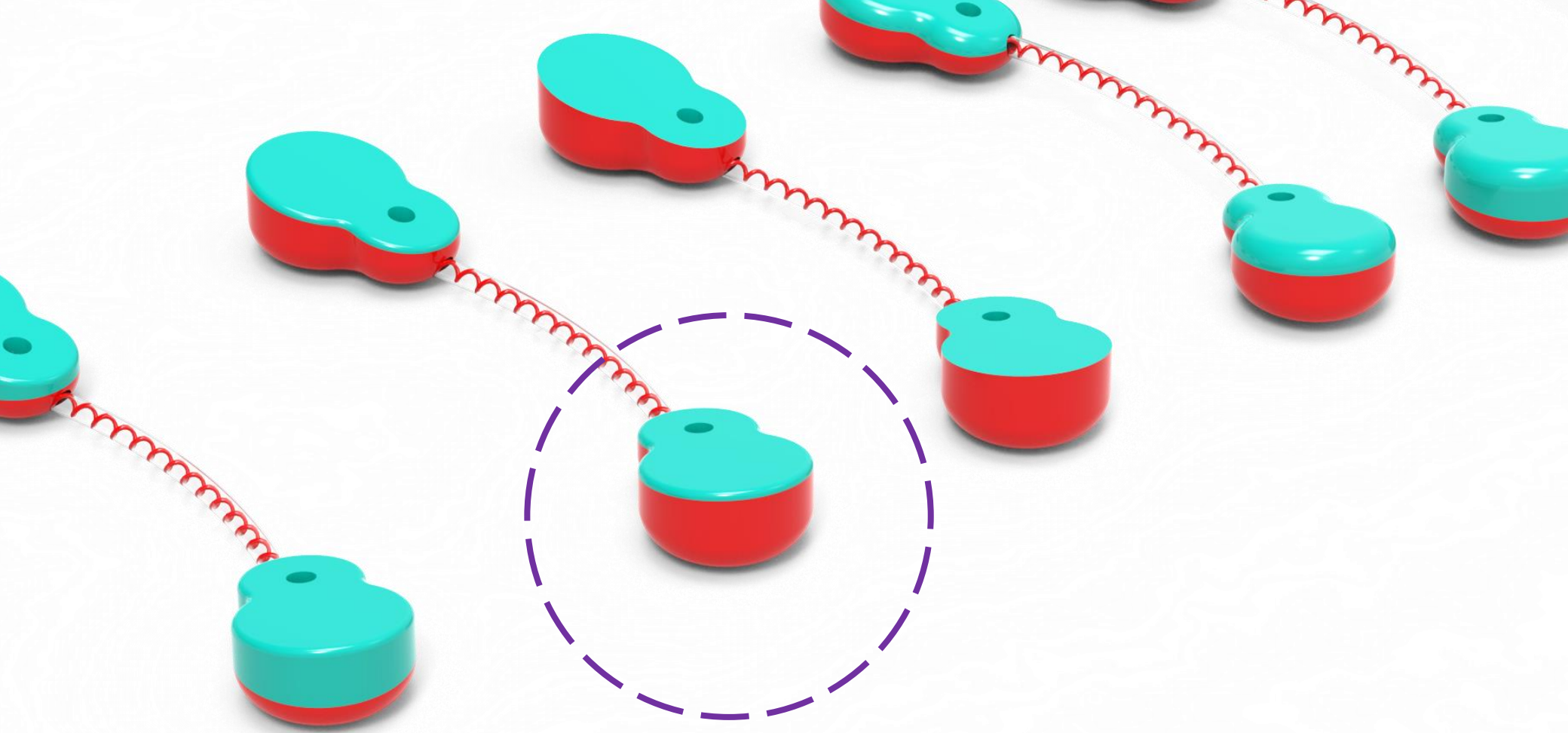

High lighted form was chosen as it was best suited for the considerations mentioned previously.

The Brace

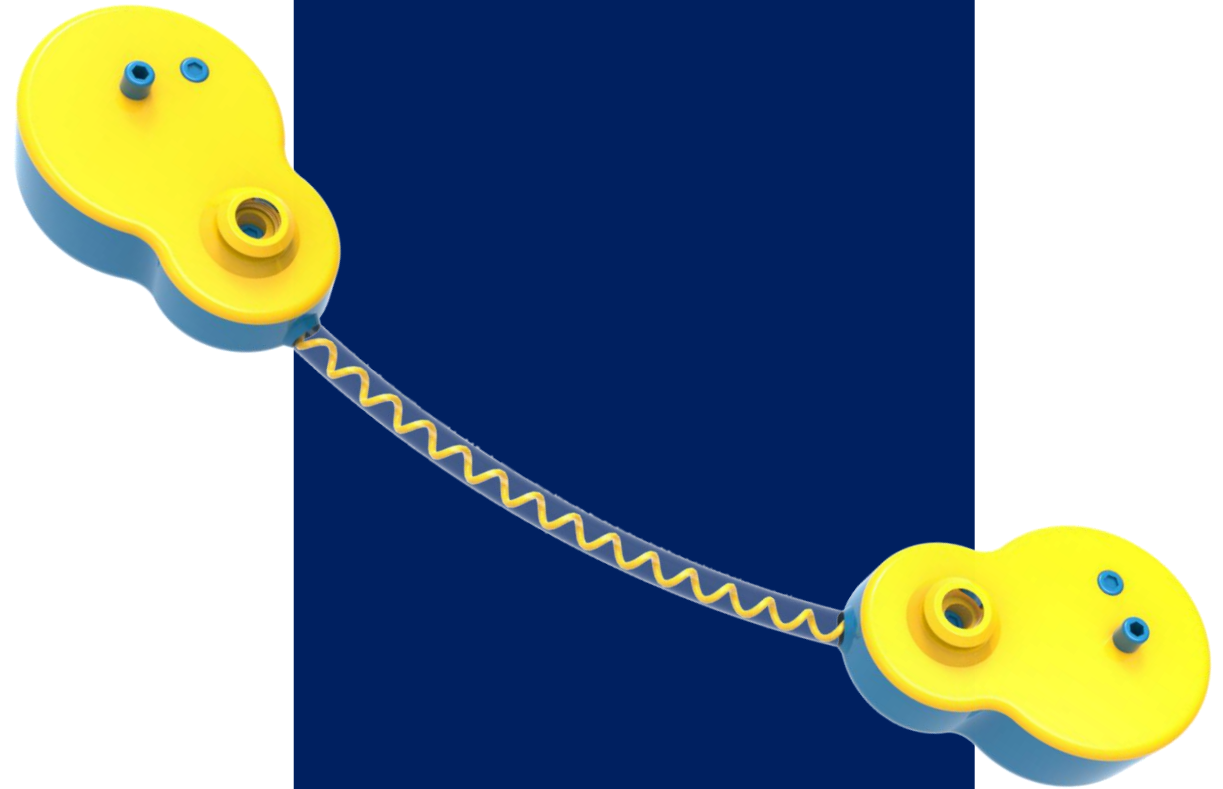

The Exploded View

- The brace is parted at the interface of the top cap and the bottom of the brace.
- The two pieces at the end of the brace bar hubs the PCB Module and the battery.
- The transparent brace bar would be a Clear PVC extrude pieces formed to a curvature. The end pieces be then injection molded on the brace bar creating a one piece configuration.
- The two top caps would be completing the assembly after fastened with three screws on each side.
- Top cap and the bottom of the brace to be manufactured in ABS by injection molding.

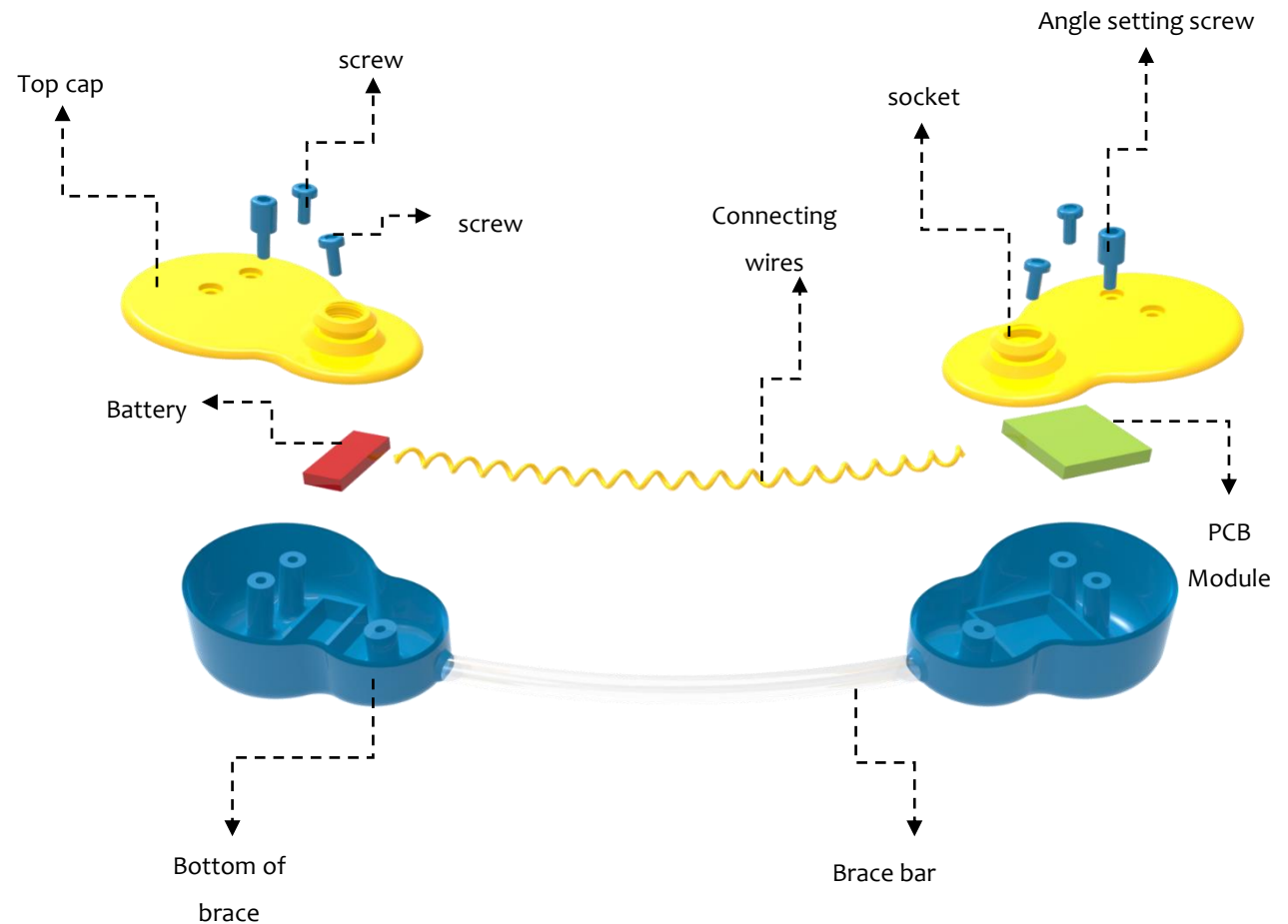

Stable Base

- The brace bottom would be padded by rubber sheet, pasted or press fitted, providing for better stiction on the ground.
- This will help baby/child to be in a standing position whenever required in the course of bracing.



The Foot wear



Tongue/cushion

Belts

Sole

Insole

Buckle

Unlocking handle



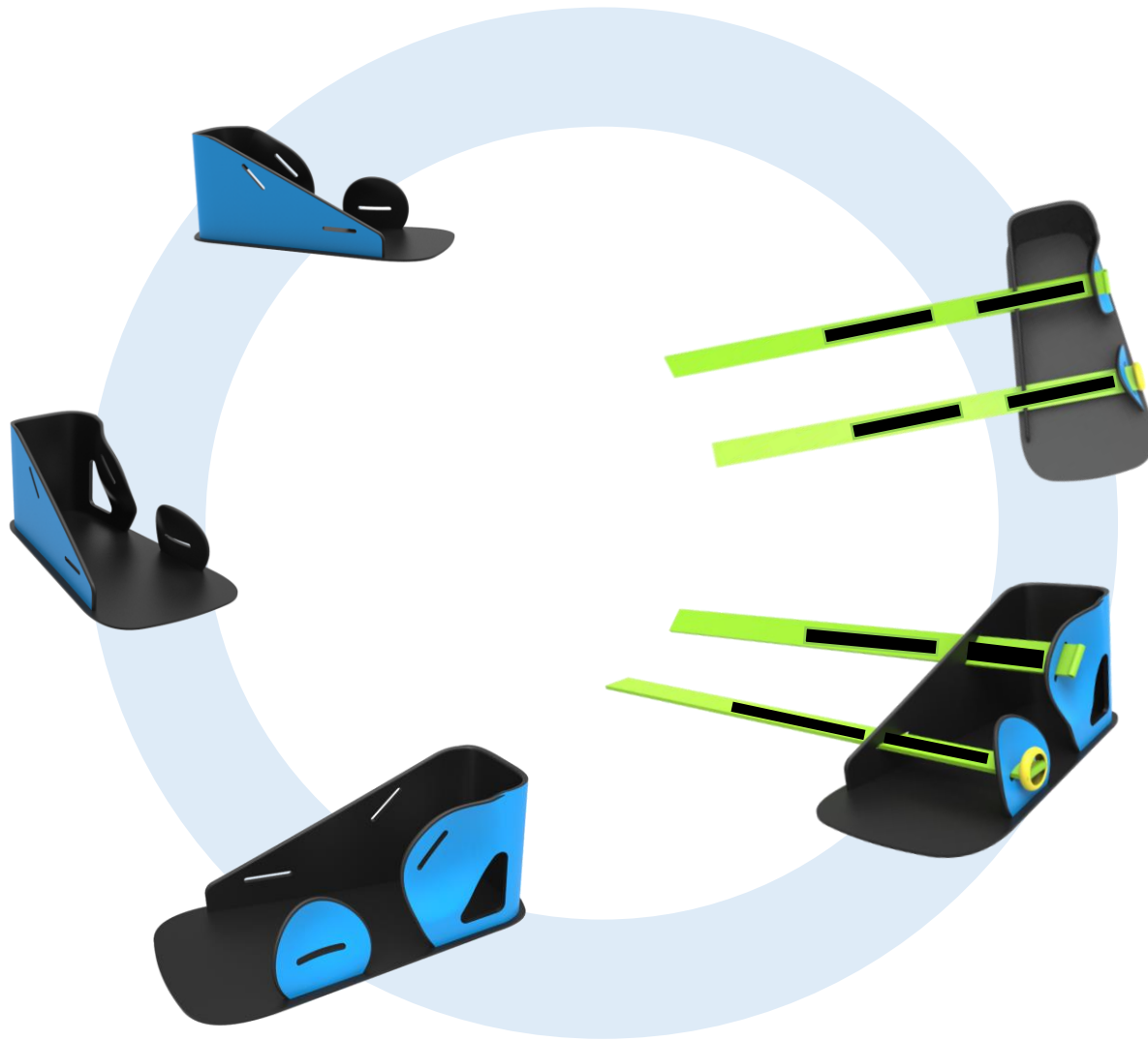

- The shoe walls are constructed in two pieces, thus, breaking the wall to aid visual accessibility for foot and for more permeability of air for soothing skin irritation.
- The straps comes separate and are Velcro fastened before buckles are used to tighten the straps.

- The shoe is to be made out of canvas as material with the inner lining of cushioning for comfort.
- The shoe would then be stitched on the cotton board base.
- The stitched shoe now can be riveted upon the sole by aluminium rivets. This provides for easy replacement of the shoe if damaged or when needs to be discarded/ or sterilize.
- The sole be then assembled with the locking mechanism and closed with a cover by three stainless steel screws.
- The shoe sole, inherently during manufacturing, be incorporated by the sensor from the top.

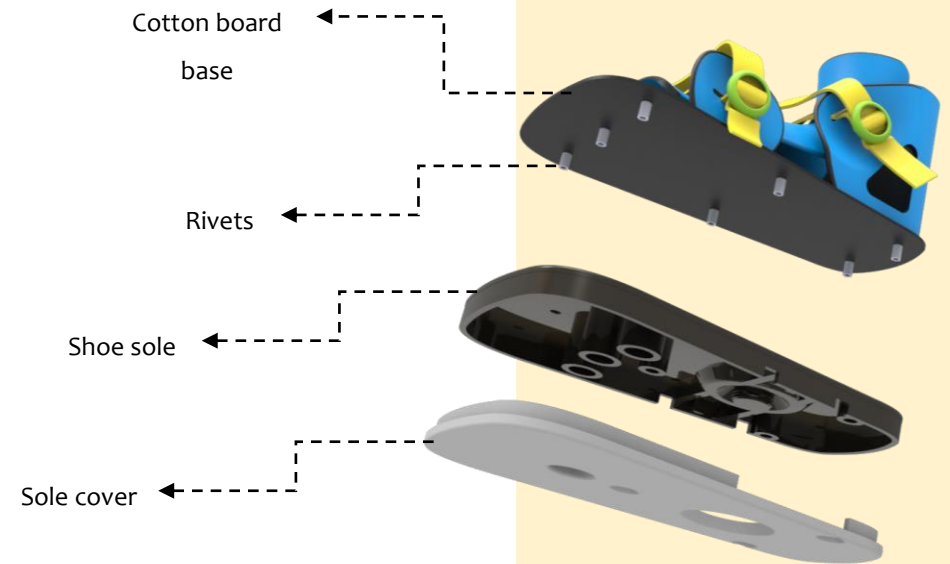

- The shoe is provided with a large tongue to cover up the foot from top for comfort against the tightness of belts.
- The shoe is supported by the a sole that hubs a mechanism to lock on the brace. The sole may also be subjected to the body weight of baby partially or fully for smaller or longer durations.
- Hence, the material of sole and the sole cover should be strong and sturdy. Also, it should be impact resistance. So, it can be manufactured from ABS [acrylonitrile butadiene styrene] by injection molding as a production process.



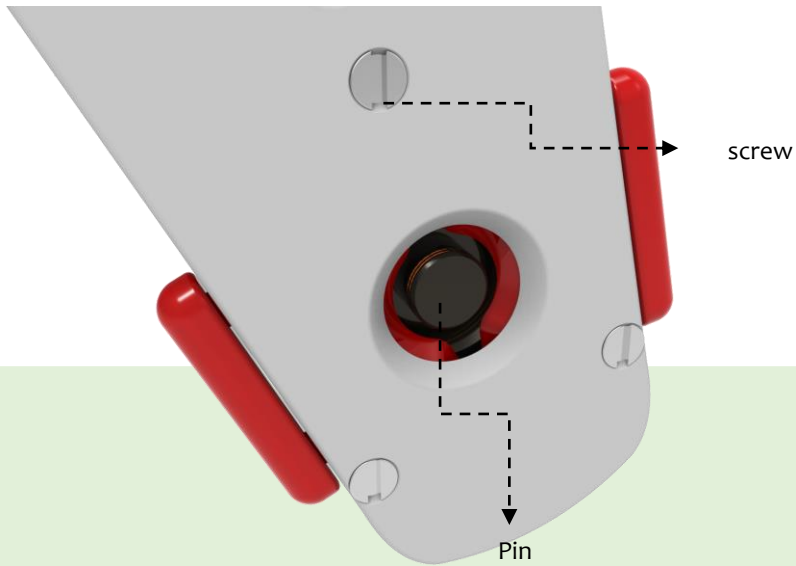

- The pin and the socket are coupled together to establish a connection for inputs from sensor.
- Pin and socket connection maintains the contact at connection point irrespective of any angular dislocation.

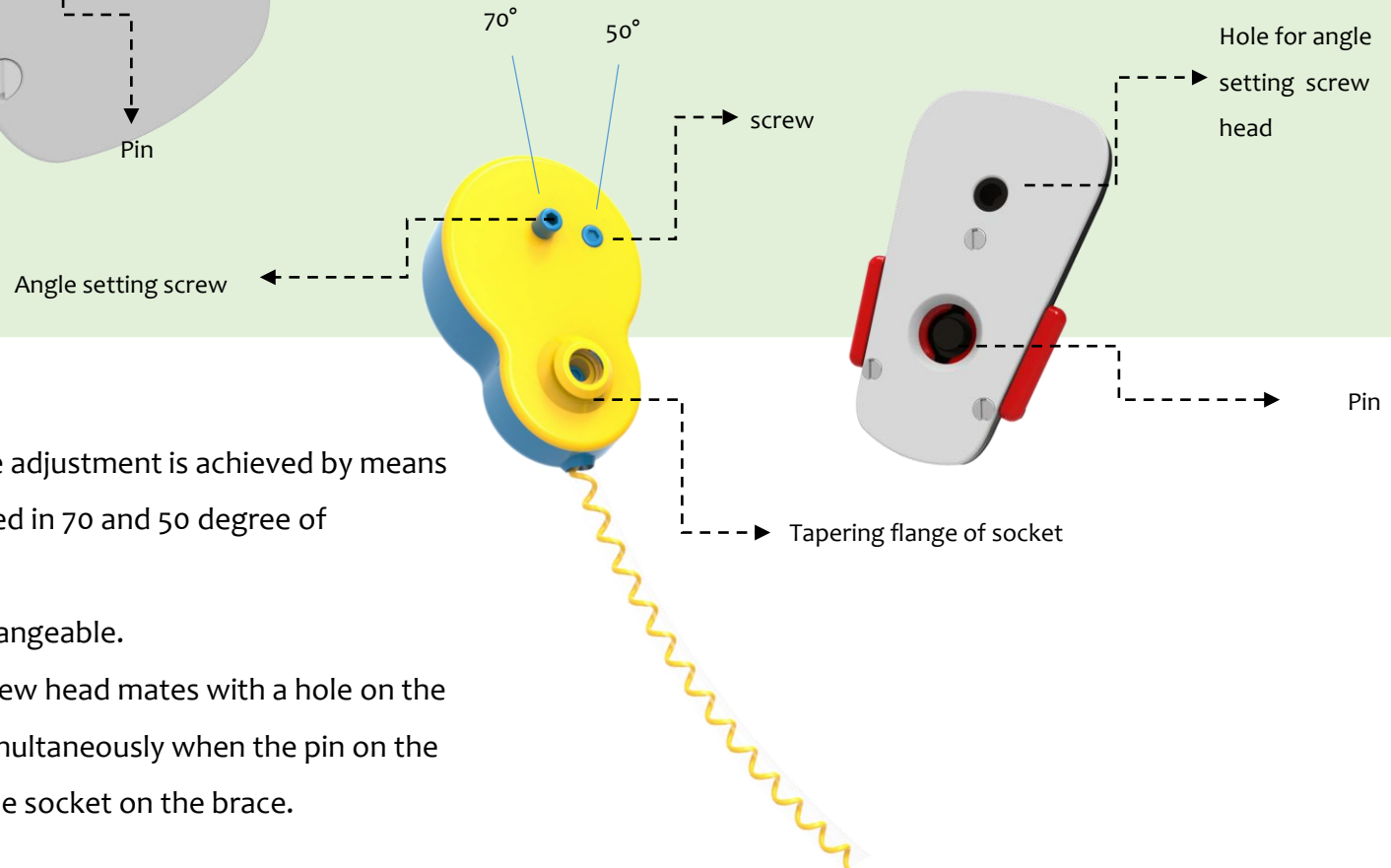

- The provision of angle adjustment is achieved by means of two screws oriented in 70 and 50 degree of abduction angle.
- The screw are interchangeable.
- The angle locating screw head mates with a hole on the bottom of the sole simultaneously when the pin on the sole is inserted into the socket on the brace.

- The FSR sensors are to be soldered on a contact point over the sole. The sensor then would be coated with a transparent PE [poly-ethylene] sticker to fix it temporarily on the sole cover.

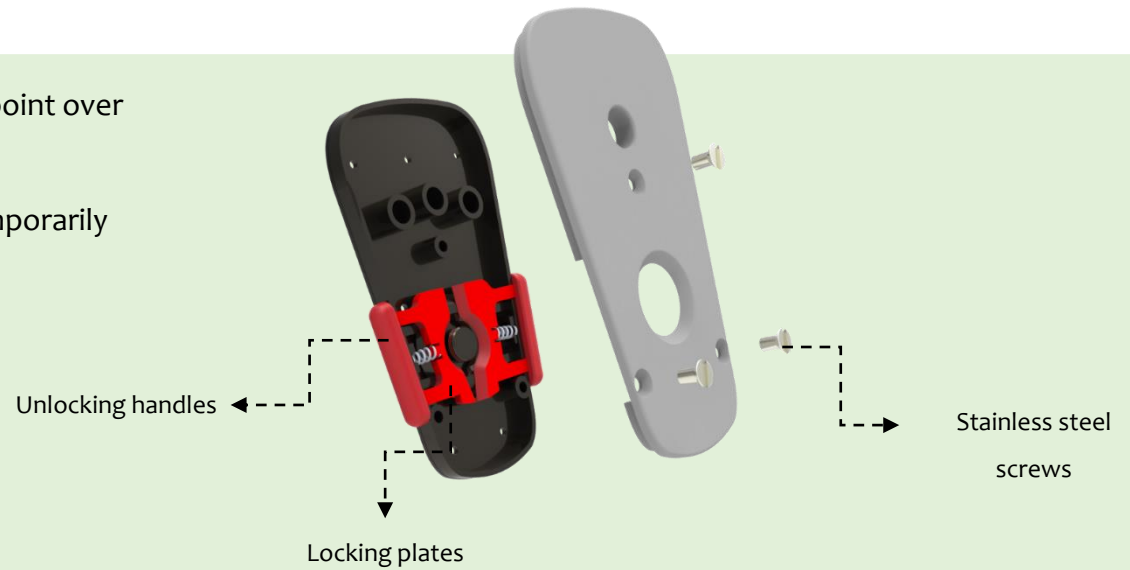
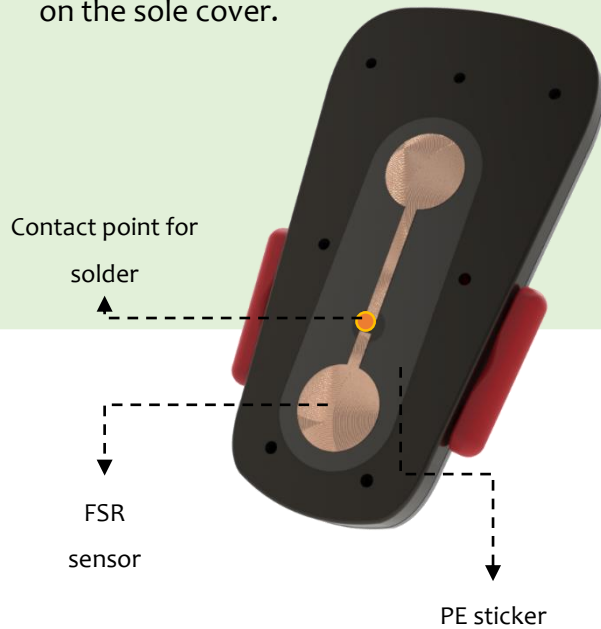

- The sole hubs the mechanism for locking upon the brace and the whole assembly is covered with a lid, put in position by 3 Stainless steel screws.
- The proposed mechanism of spring loaded sliding plates involves simple locking against a tapering flange of socket provided on the brace.
- The sliding locking plate would be manufacture by injection molding from Nylon as material for its excellent abrasion resistance. The plates can be unlocked by pulling outward the Unlocking handles

Exploring Space-bar

The rationale behind this attachment comes from the child's miss on relating with the present orthosis as an opportunity to interact with and Parent's discomfort of handling the braced babies.

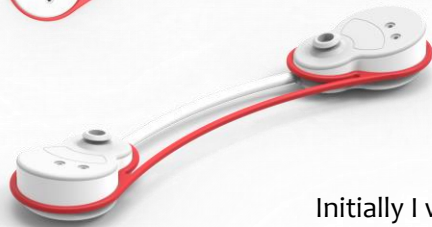

Initially I was trying to play around with the brace shape to achieve an easy wearing of bar on brace with shoes coming over it to keep in its position.

Then I flattened the bar at centre for increasing the parent's comfort while they would carry the baby, but this would not go good with the toys.



So I then unlooped the loopy bar ends at brace ends. This would help parents to put on some hollow toys over the flat band. It was looking very strong and lacked playfulness.



I tried here creating some drama out of its structure, but it was expressing lot of restrictive or fence like resemblance!

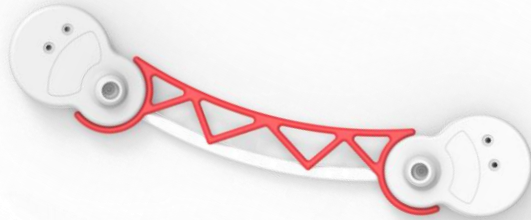

Then I tried making it simple and minimal, but here the flexibility was missing.

To add some flexing ability to the bar , I tried curving it back at the point where it connects on its ends.

But it still did not looked playful or happy enough.

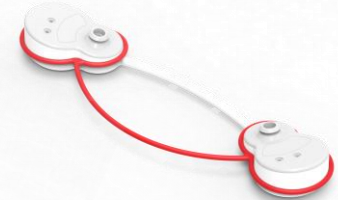

The convex curvature with the confined ends made it look really like a happy face & bouncy enough, but again the toys cannot be put through the bar here.

Then I tried varying the bar cross section from round to flat and flat to round between its end with bigger radius of back curvature.

But it looked very unreliable and fragile. It lost that visual bounciness.



Finally I made the cross-section all round uniformly throughout the bar and now it looked playful, simple and makes a static statement with the brace.

The bar now has open ends that facilitates the mounting of hollow toys over it and also retains the bouncy nature due to convex curvature and circular ends.

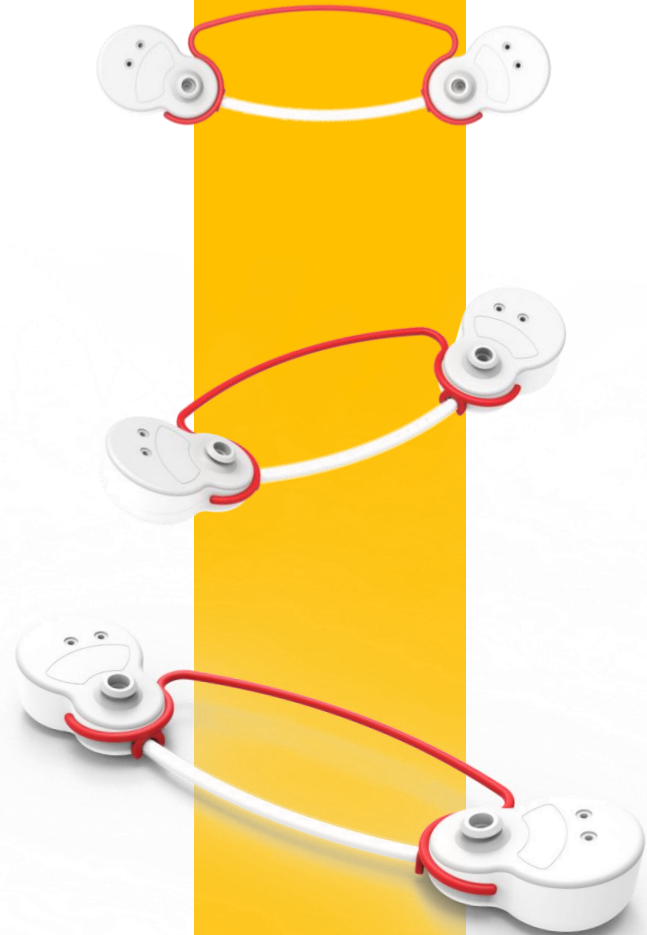

- The Space-bar can be attached and detached with a snap on the brace.
- Making it easy to attach and detach.
- Considering the resistance to steam sterilization, high flexural strength, high fatigue strength and low surface bonding properties of polypropylene [PP] plastic, the Space-bar can be produced in PP by injection molding process.

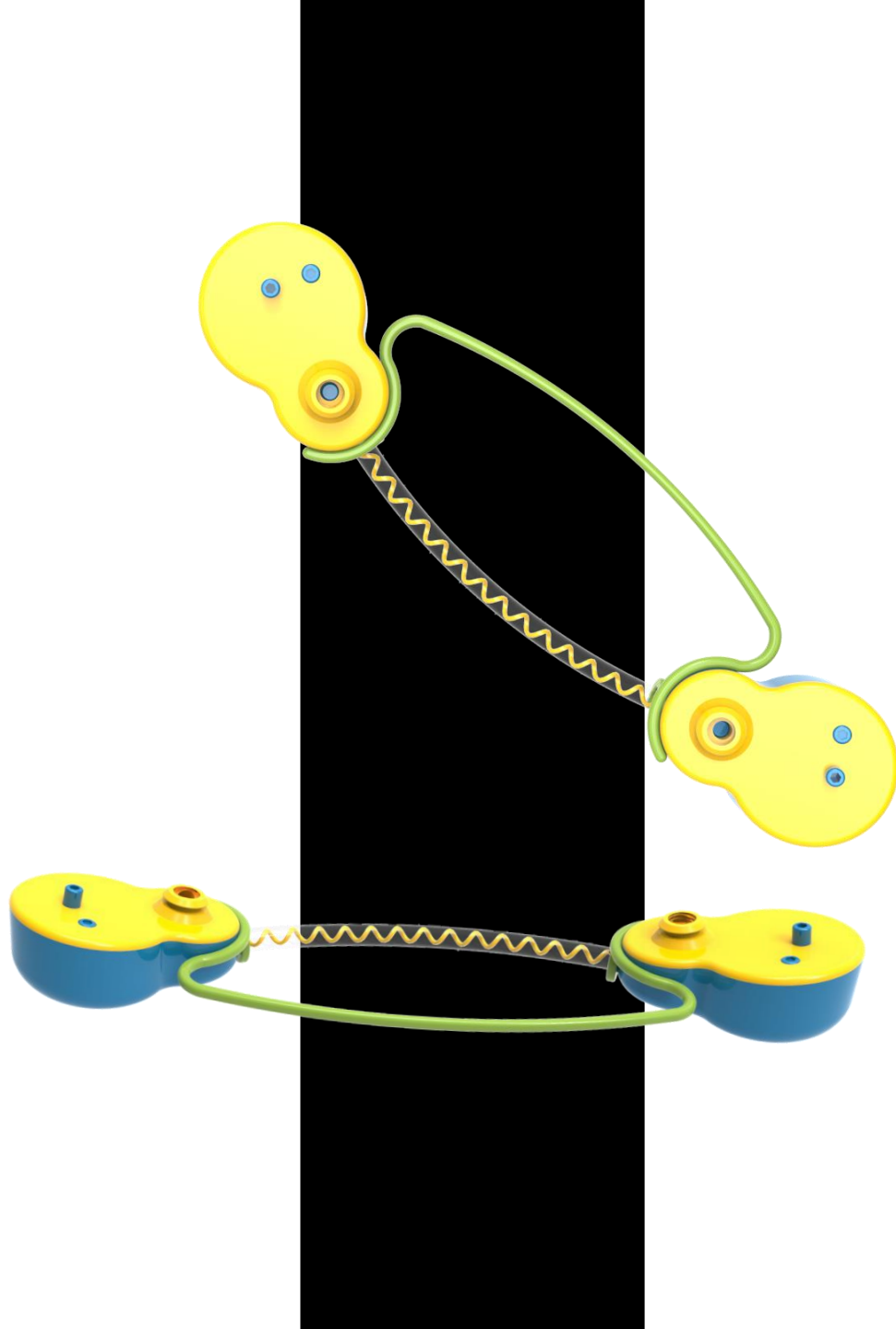



The Orthosis

The orthosis would be given to a patient as per the prescribed Brace Size and the Footwear fit. So, it would have a pair of Shoe, a Brace and the Space-Bar.

Toys for Space-bar

The major considerations for designing the toys for the bar are –

- Child's most challenging period of adapting to brace, especially, the duration of 23 hours of bracing schedule.
- Child's visual development.
- Child's physical growth, and motor skills development.
- Situations the child will be subjected
- Portability
- Variety by information
- Ease of cleaning

The inspiration for the toys came from Alphabets, Shapes, Numbers, and Motion.

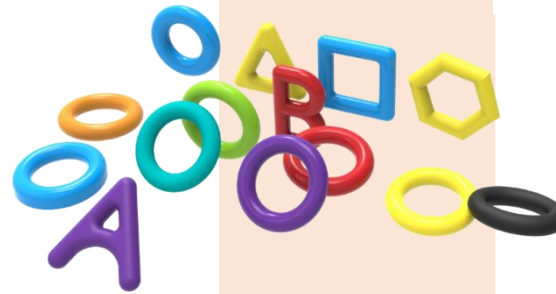
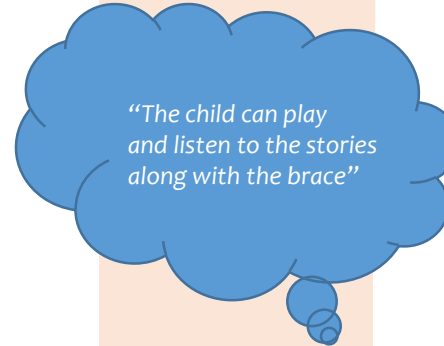



Basic Dimension

Brace

[All dimension are in mm.]

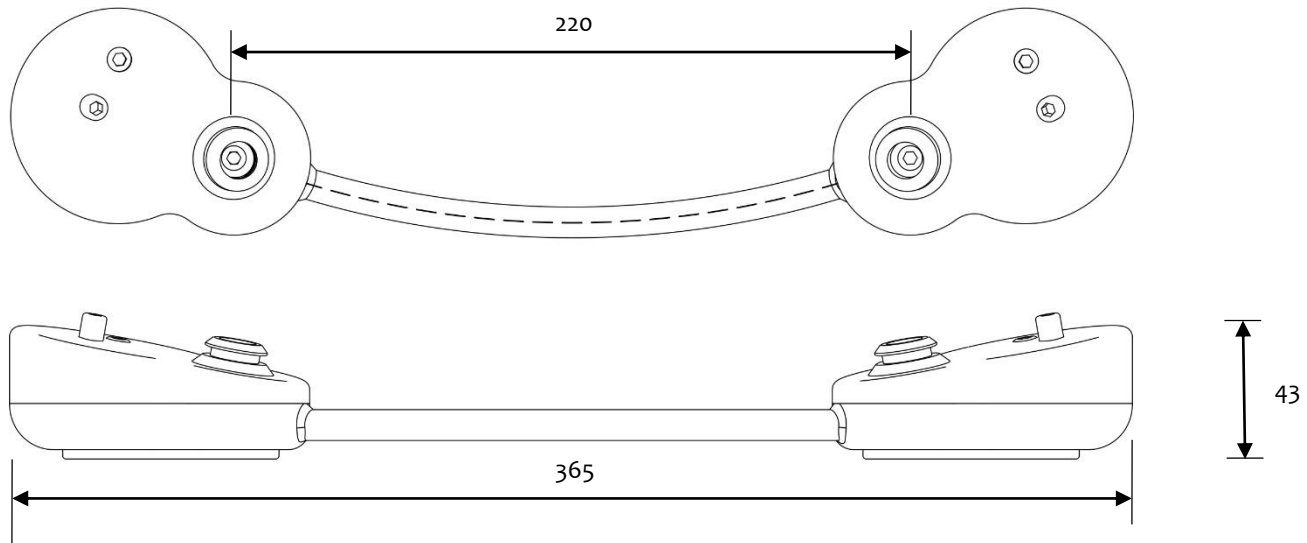

Space Bar

[All dimension are in mm.]

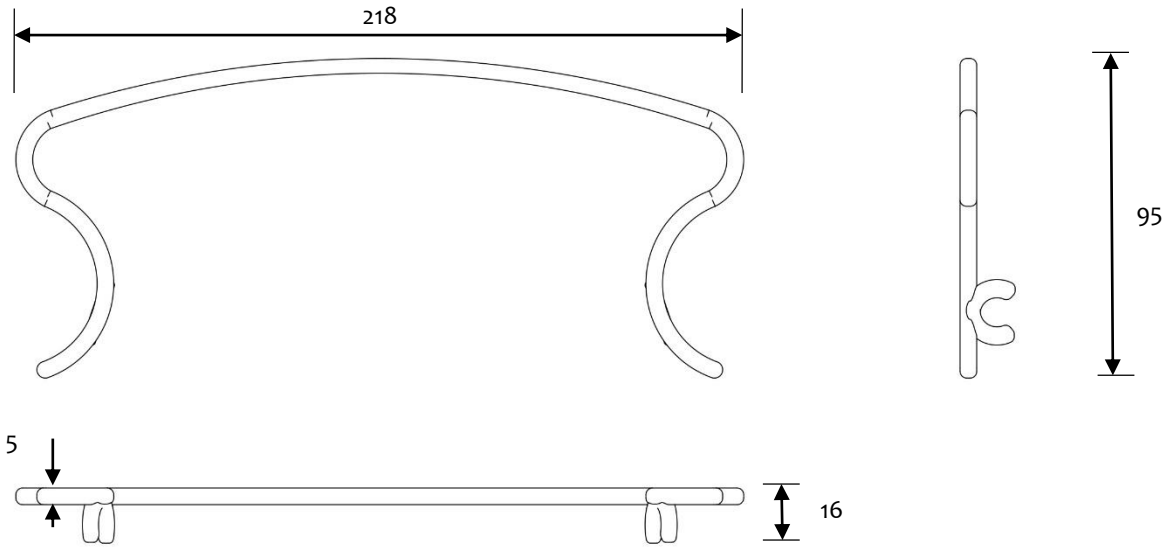

Sole box

[All dimension are in mm.]

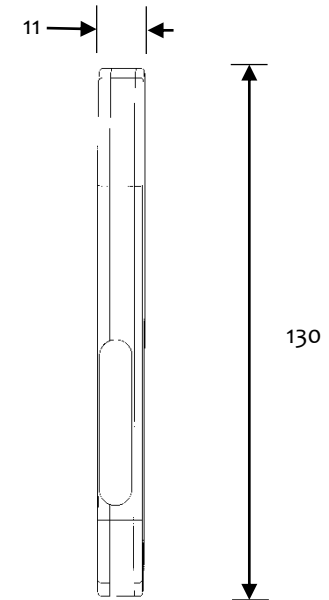
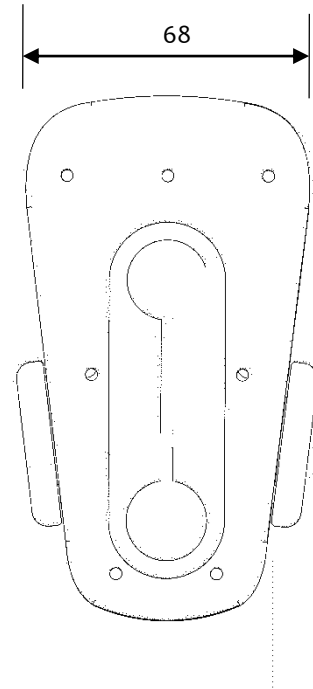

Shoe

[All dimension are in mm.]

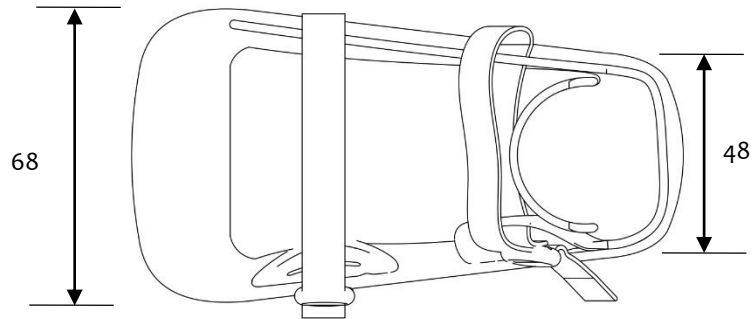
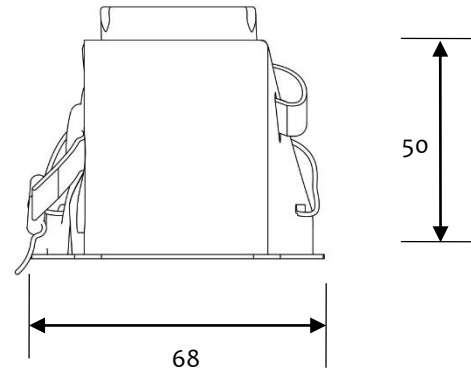
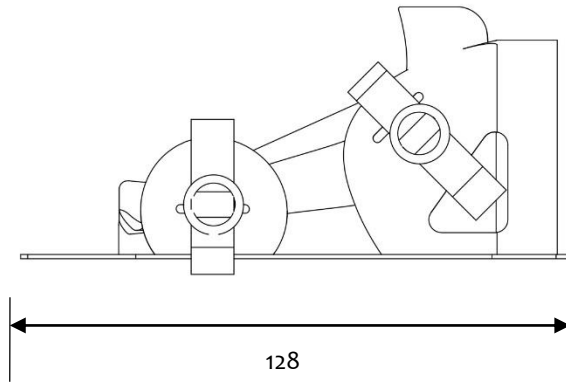

Chapter 12

User Testing & Feedback

The user testing was carried out at clubfoot clinic in

B J WADIA Hospital, Parel.

Attempt 1

- The mother of the child was explained the procedure to brace and asked to perform the bracing. As per the desired protocol, she put the shoes first as shown in fig. 12.1 and fig. 12.2 respectively and then the brace.
- Before bracing the shoes, she tried understanding the locking and unlocking of the shoe as shown in fig. 12.3 and fig. 12.4 respectively.
- Initially she tried putting the brace slowly to understand the procedure of locking and unlocking. She repeated the bracing procedure after fully understanding the new bracing procedure as shown in fig. 12.5 and fig. 12.6 respectively.



FIG. 12.1



FIG. 12.2



FIG. 12.3



FIG. 12.4



FIG. 12.5



FIG. 12.6

First round of feedback:

- Accessible unlocking eliminates the turning of feet to unlock as in Stanford brace.
- With lace, child will try to take off the leg out of shoe or sometimes he will try to raise his heel inside. This I did not feel with the belts as visual access is increased.
- The shoe was very quick to put on.
- The locking unlocking was difficult initially, but after I learnt it, it was very easy to lock . However , unlocking is still uneasy. An old person may not be able to open it.

Feedback from
Dr Sourabh Sinha
[Consultant for Clubfoot Project at BETiC]

Feedback:

- As far as functionality is concerned, the brace looks pretty good.
- The provision of brace accessory for the child is a good thought.
- As the shoes are redesigned, we need to validate them by a pilot.
- The duration while the child is wearing the brace for 23 hours, child is not mature enough to unlock the brace, so the locking can be simplified.

Attempt 2



FIG. 12.7



FIG. 12.8

Another user with simpler locking [the with the back locking plate removed] was tested as shown in fig. 12.7 and 12.8 respectively.

Second round of feedback:

- Shoes are very softer and fast to do.
- Lacing is kind of frustrating , often makes us impatient.
- The locking-unlocking procedure is also very simple.
- The brace is more portable as we can detach the shoe.
- It would be good if the brace would be lighter.

Chapter 13

Branding

StepWell Orthosis



FIG.13.1 STEPWELL LOGO

The Inspiration for entitling the Brace as StepWell
Brace came from one the User's experience
about his treatment of club foot.
Describing which he explained that initially when
he was on the rugged shoe for the treatment, it
was very painful. But gradually when he observed
that his pain help helped him step well and
better, he felt very happy about the shoes he
wore.

The logo is inspired from the form of the product,
where the word Step is symbolically resembled
by the dots and the word Well is expressed
through the foot profile and the curls of
connecting wire.



Future Scope

- *The next step of the project will be plastic engineering of the design, to perform simulations to optimise the design, to produce working prototypes and testing them extensively.*
- *Followed by validation for design for its effectiveness of Abduction and User compliance.*
- *The next phase of project should also focus on specifying the shoe sizes, number of sizes and brace size standardisation.*
- *Once the design is validated, the brace and the shoe can be manufactured and distributed by NGOs and Clinics within to the patients.*

Conclusion

- This project was an **inclusive opportunity** to understand and learn about one of the **confined health care systems, unidentified healthcare needs and conventionally accepted system/solutions in the country.**
- It surfaced the **significant scope of design intervention in health care for a developing country like India.**
- During the course of this Project, the Users and the Clinician has shown keen interest in the problem solving and spoke their hearts out about **how they lack or miss upon the precise, affordable and qualitative solutions to deal the untouched entities like clubfoot treatment.**
- The final proposed design was discussed with Clinicians and the Users, to which, the feedback given was quite positive and motivating.
- In this project, **redefining of bracing protocol was attempted** and it's actual effectiveness and scope for improvement can be more understood after prototyping and testing of the product.

References

Web References

1. <https://www.ncbi.nlm.nih.gov/pubmed/23586398> dated 5/02/2019
2. <https://www.nhs.uk/conditions/club-foot/> dated 5/05/2019
3. <https://doi.org/10.1111/jpc.12167> dated 7/02/2019
4. https://en.wikipedia.org/wiki/Child_development_stages dated 7/02/2019
5. <https://sciencing.com/do-bright-colors-appeal-kids-5476948.html> dated 7/02/2019
6. <https://www.nhs.uk/conditions/pregnancy-and-baby/your-baby-after-birth/#/> dated 10/02/2019
7. <https://orthoinfo.aaos.org/en/diseases--conditions/clubfoot/> dated 5/02/2019
8. https://www.who.int/surgery/challenges/esc_congenital_nomalies/en/ dated 5/02/2019
9. https://www.indexmundi.com/india/demographics_profile.html date 6/02/2019
10. <https://www.miraclefeet.org/our-work/partners/india/> dated 6/02/2019
11. <http://www.coastalorthopaedics.com.au/foot-ankle-anatomy-coastal-orthopaedics.html> dated 6/02/2019
12. <https://www.dobbsbrace.com/dobbs-bar.html> dated 6/02/2019
13. <https://www.clubfootsolutions.org/wp-content/uploads/2017/06/Clubfoot-Solutions-Users-Manual.pdf> dated 6/02/2019
14. <https://markellshoe.com/abduction-bars.html> dated 7/02/2019
15. <http://iowabraces.eu/index.php/en/> dated 7/02/2019
16. <https://mdorthopaedics.easyordershop.com/link/en/bars/c/> dated 9/02/2019
17. <http://www.360oandp.com/orthotics-101-denis-browne-bar.aspx> dated 10/02/2019
18. https://en.wikipedia.org/wiki/Denis_Browne_bar dated 10/02/2019
19. http://www.joas.in/temp/JOrthopAlliedSci2234-3377667_005617.pdf dated 15/02/2019
20. https://www.physio-pedia.com/Pirani_Score dated 15/02/2019
21. <https://www.clubfootsolutions.org/iowa-brace/> dated 15/02/2019
22. https://storage.googleapis.com/global-help-publications/books/help_steenbeekbrace.pdf dated 17/02/2019
23. <https://link.springer.com/article/10.1007/s00264-018-3873-3> dated 17/02/2019
24. <https://www.aoa.org/patients-and-public/good-vision-throughout-life/childrens-vision/infant-vision-birth-to-24-months-of-age?sso=y> dated 15/02/2019
25. <https://sciencing.com/do-bright-colors-appeal-kids-5476948.html> dated 19/02/2019
26. <https://www.physio-pedia.com/Prosthetics> dated 19/02/2019

Image References

- FIGURE 1.1 <https://orthoinfo.aaos.org/link/1da43939a3fd4d228f7bccf8af172fde.aspx>
- FIGURE 1.2 <https://emedicine.medscape.com/article/407294-overview>
- FIGURE 1.3 https://www.Fyzical.Com/boerne/media/img/351574/clubfoot_intro01.Jpg
- FIGURE 1.4 <https://clubfootclub.org/wp-content/uploads/2010/06/ponseti-cast-card1.jpg>
- FIGURE 1.5 https://pro2-bar-s3-cdn-cf1.myportfolio.com/4c4c5b43d9721670b083172df179a66d/2fb8c845370215.582e157e94e1c_car_1x1.jpg?h=bc5f656a6cd4fbcc05678a05f5826of0
- FIGURE 1.6 https://pro2-bar-s3-cdn-cf4.myportfolio.com/4c4c5b43d9721670b083172df179a66d/fc45bf95-76e3-4a16-a36e-807e6125e169_rw_1200.jpg?h=55eod49dfd2886d921bob8e8ce63bddb
- FIGURE 1.7 <https://0515f2af61d5e3d37aec-a1d11e7882f6a6aa49a62729309b6434.ssl.cf2.rackcdn.com/2016/06/sewing-machine-web-600x400.jpg>
- FIGURE 1.8 <https://145gjhchid5e3d37aadhgsajchbsa-1d11e788j8565a49a62729309585.sl.cf2s.rackcdn.com/2016/06/club-foot-web-600x400.jpg>
- FIGURE 1.9 https://www.jbjs.org/elensreader.php?id=30383&rsuite_id=1705134&type=jpeg&name=JBJS.17.01049f3b&subtype=
- FIGURE 1.10 https://media.springernature.com/lw785/springer-static/image/art%3A10.1007%2Fs00264-018-3873-3/MediaObjects/264_2018_3873_Fig1_HTML.gif
- FIGURE 1.11 https://www.researchgate.net/profile/Ayman_Jawadi/publication/40900581/figure/fig1/AS:341427298029568@1458414019448/The-Pirani-score.png
- FIGURE 9.2 <http://lfaclinic.co.uk/wp-content/uploads/2014/11/Slide12-300x179.jpg>
- FIGURE 4.3 https://www.clubfootsolutions.org/wp-content/uploads/2016/12/brace_side_300x300.jpg
- FIGURE 4.6 http://iowabraces.eu/assets/images/img_iowa_brace_03.jpg
- FIGURE 4.7 <https://www.dobbsbrace.com/images/dcb.jpg>
- FIGURE 4.8 <https://markellshoe.com/img/img-1645e.png>
- FIGURE 4.9 <https://markellshoe.com/img/1934d.png>
- FIGURE 4.10 <https://www.dobbsbrace.com/images/dcb-cover.jpg>
- FIGURE 4.11 <https://markellshoe.com/img/denis-brown-bar.jpg>
- FIGURE 4.12 <https://markellshoe.com/img/denis-brown.jpg>
- FIGURE 5.36 <https://image.slidesharecdn.com/12-150417055625-conversion-gate01/95/transfemoral-static-alignment-4-638.jpg?cb=1429250744> dated 19/02/2019

