

Wearable Product for Professionals

Guided by
Prof. B. K. Chakravarthy

Sarang Kusale
07613002

Current Trends...

Carry with you always....



Wearable products

as a future trend

Entertainment



Gramophone
(1887)



Long Play
Records
(1947)



8 track
Magnetic Reel
(1965)



Cassette player &
recorder
(1964)



Walkman (1979)



CD Player
(1982)



i-Pod series



MP3 Players



i-phone



Concept
phones

Communication



Electric telegraph (1835)



Mobile telephone service (1946)



Cellular radio network (1980)



GSM (1991)



SMS (1994)



Era of Mobile phones (1998)



3G handsets (2008)



Design Brief...

To design a **wearable** product

for **communication** and **entertainment**

For **young professionals** up to **30** years old,

Who are working in **corporate culture**

The focus will be on **User Delight**

the design is going to be driven by **aesthetic explorations**,

Using **innovative technology** four years from now

User

Defining the User



Young Professionals

Corporate work culture

Age group : 20~30 years old

- Party goers
- Staying connected with friends and business networks
- Want to make a statement of identity
- Love to have gadgets
- Living single or with roommates/friends

The User



Other facets

- Zapping Mentality*
- Decision maker
- Keep themselves updated with latest trends and technology
- Income per month (INR)
 - 15,000/- to 25,000/-
 - 25,000/- to 60,000/-

*Reference:

Shining Universe, Shombit Sengupta, Mobility in India 2016, Styling & Design Conclave 2009

Lets hear what **they** think...

Users' opinions about the headsets

"I hate the mess of wires" -

"I like to talk with headset" -

".....?" -

"I use the head set for listening the songs when I have some free time and I use it very rarely" -

"...for personal talk" -

"I feel more personal with earphone" -

"I use the earphone only with my i-pod for listening music. For do not prefer them for phone calls" -

"its very convenient for talking" -

"Problems?.....
I never considered..."

"..with this, I feel free while talking"

"I like to listen FM while traveling" -

"I prefer earphone for long conversations"

"....this Bluetooth headset is always with me...and I use it for phone calls..."

Users' opinions about the headsets

"..I like to hide the wires"

"...I don't like to show-of..." -

"...this Bluetooth headset is always with me...and I use it for phone calls..."

"jewellery cum gadget would be a great thing" -

"whenever I am alone, I use this headset" -

"I feel comfortable in rush" -

"It detaches me from local rush and noisy environment"

"its became a part of life.. I always carry with me" -

"I use it whenever I am lonely" -

"I like trendy and techie things" -

"I use minimalistic jewellery... I personally might not prefer a jewellery gadget, but it depends on style and trends" -

"Sorry, don't take photo" -

Observations



They always carry with themselves ...
(serves as companion)

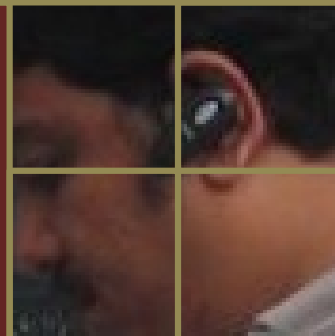

While using earphones, people generally keep mobile in hand.

A part of daily life.

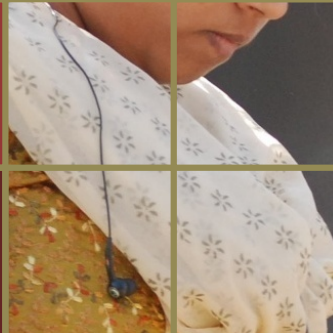

The wires are deliberately hidden

Mobile screen is not frequently used, when the person is having very personal chat.



The voice-receiver piece is frequently adjusted or it is held very close to mouth by using a hand.



Earphones are not used as show-of element

Techie, stylish and trendy gadgets are always adorable

Ideation...

Keywords...

Techie

Stylish

Interaction

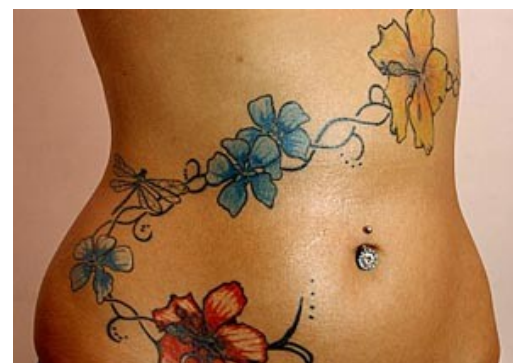

Inspirations...

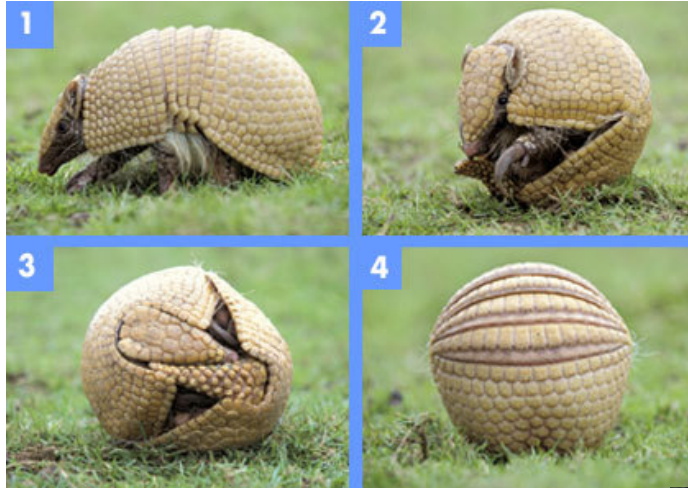

Capturing the gestures...

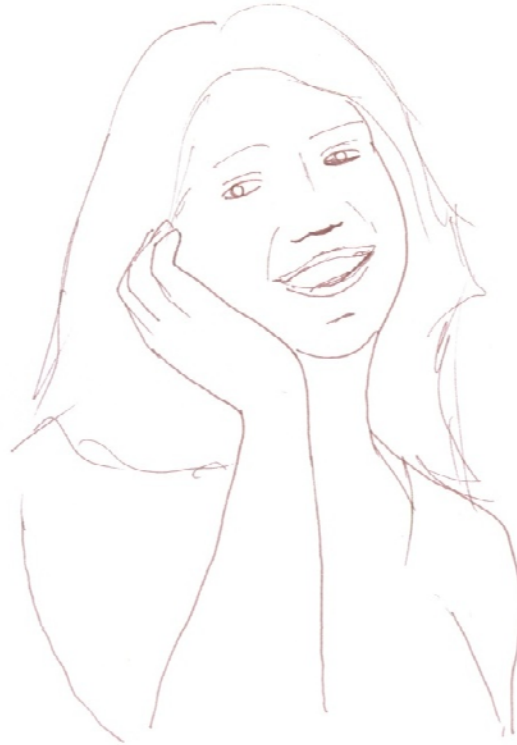

Ideation...

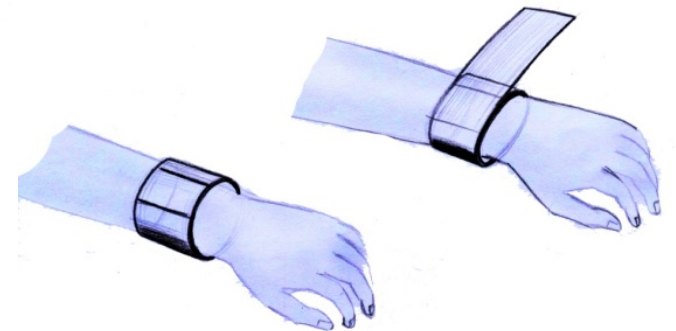
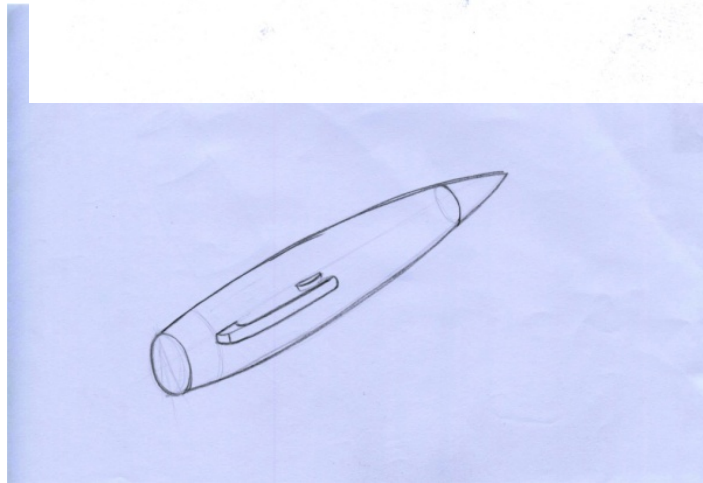
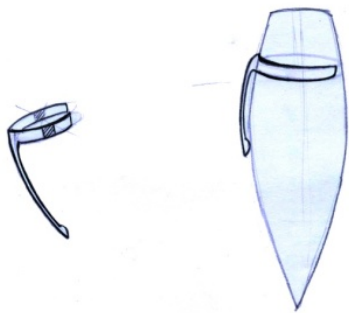
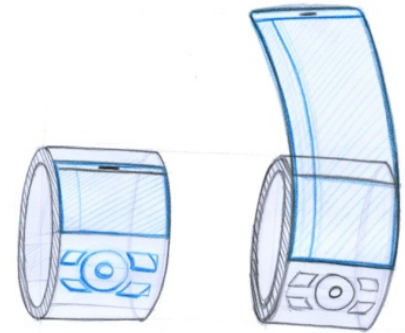
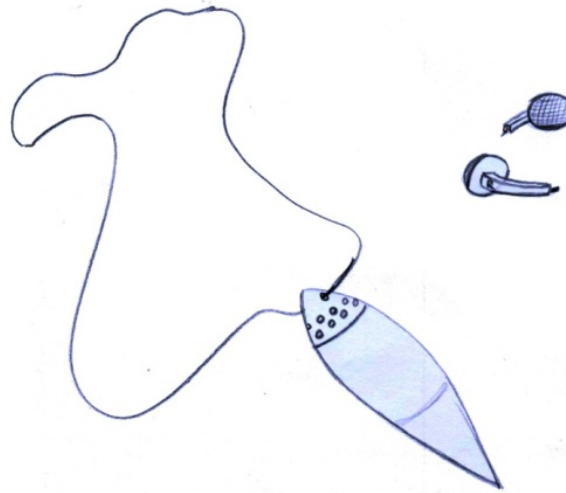
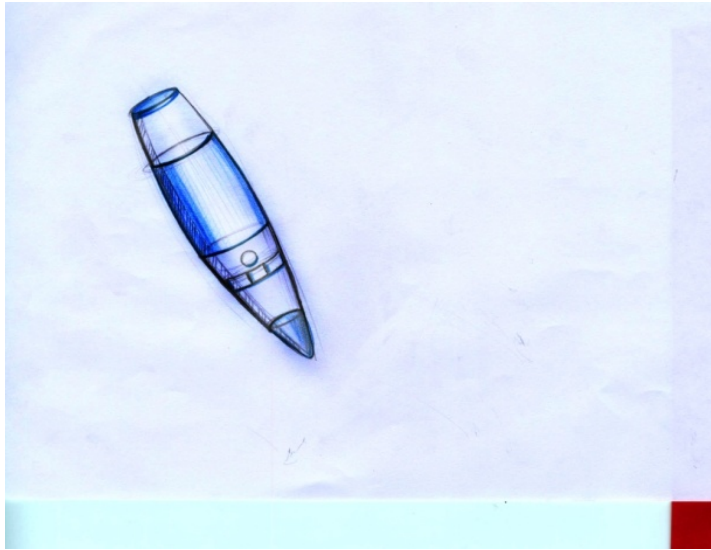

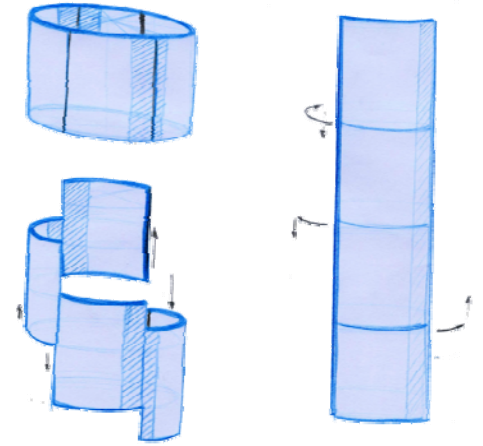
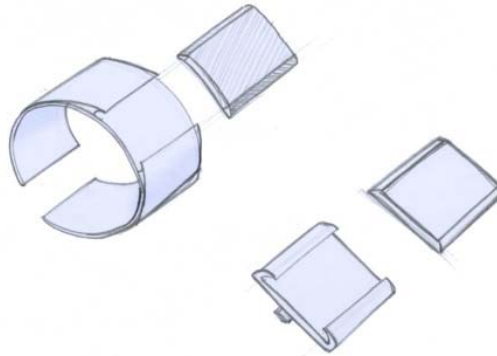
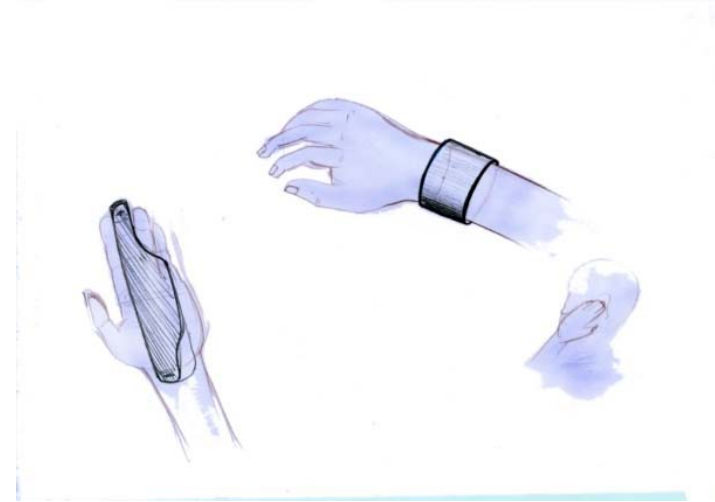
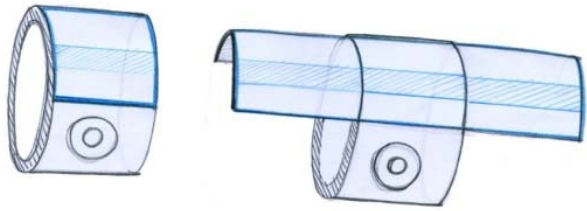

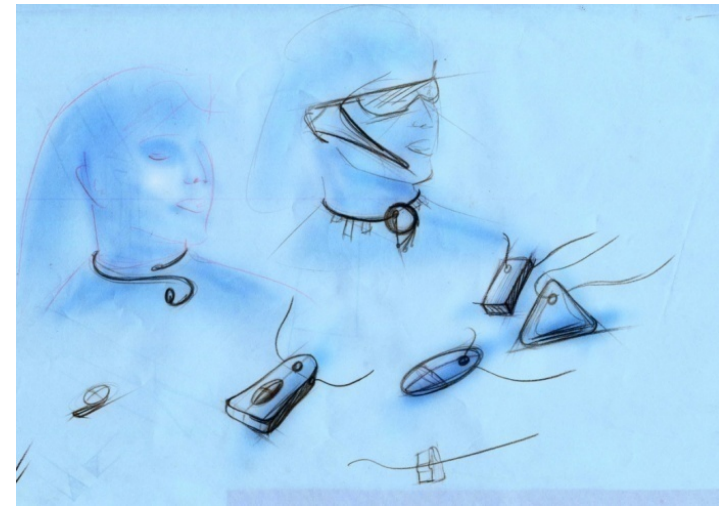
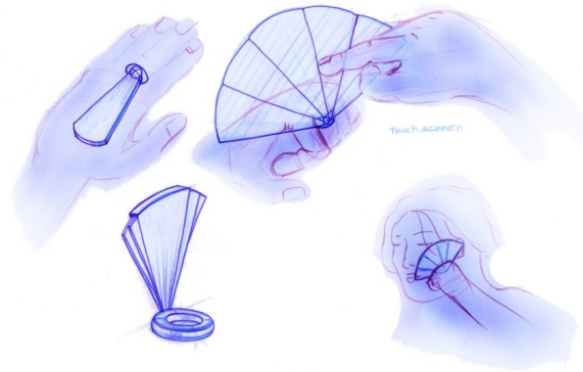
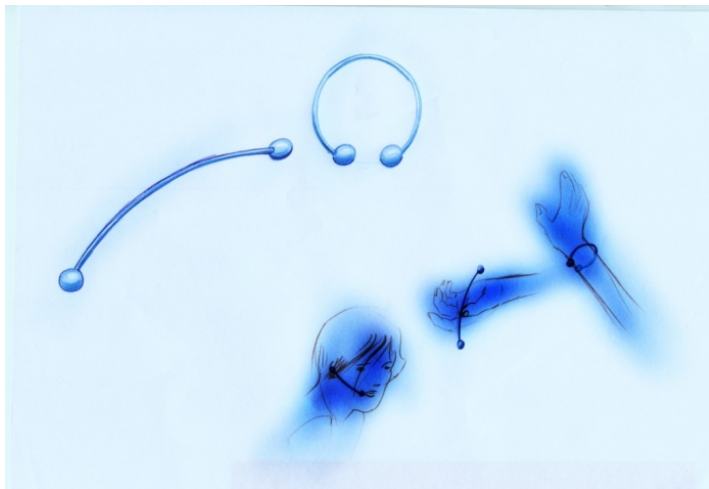
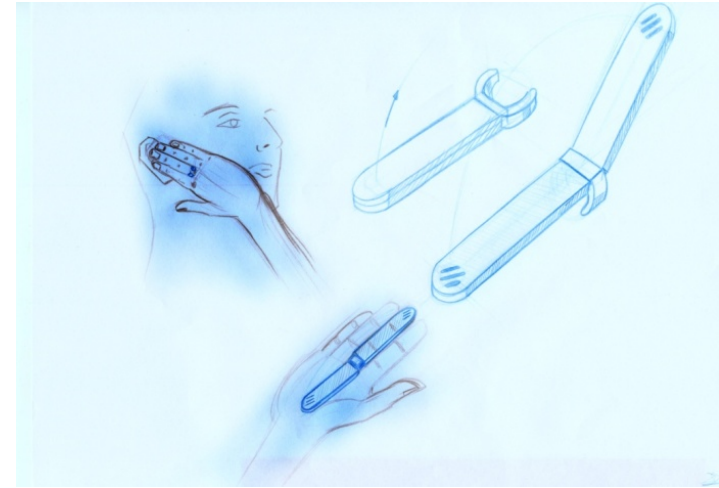
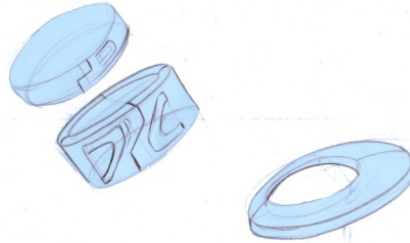
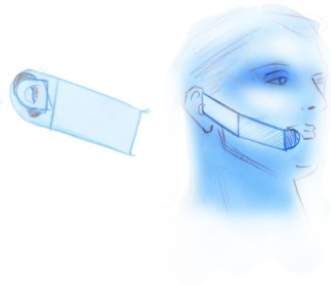
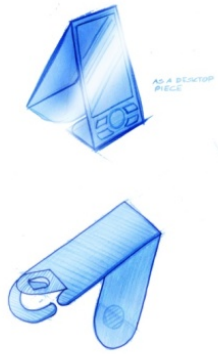

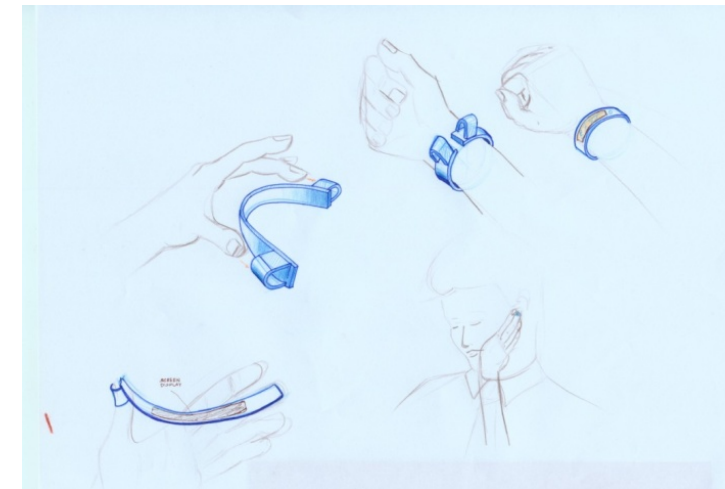
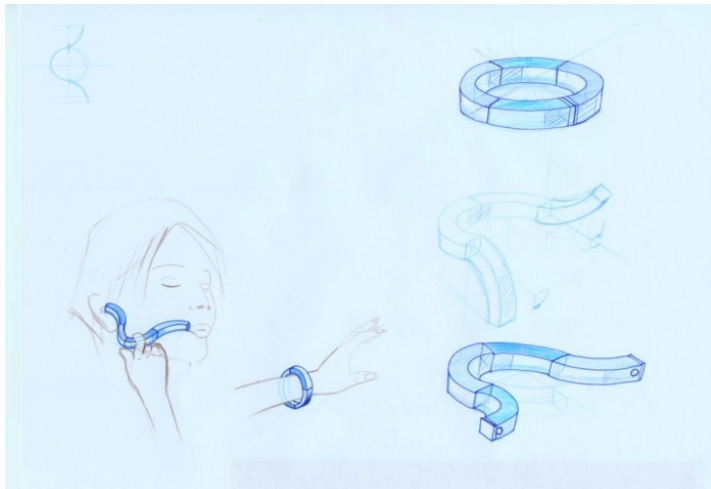
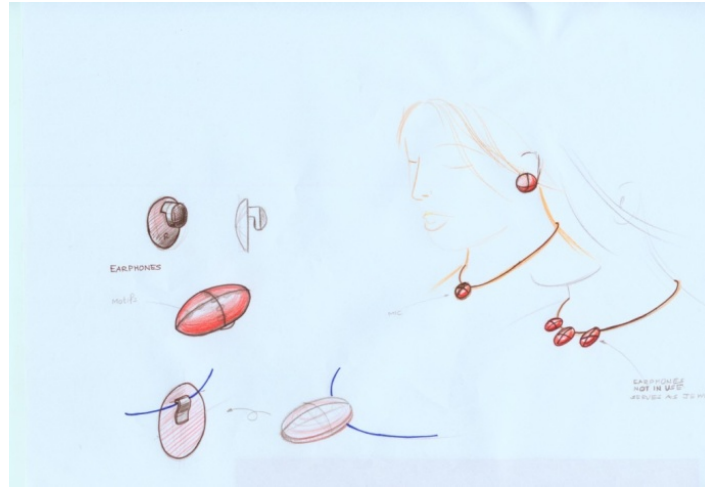
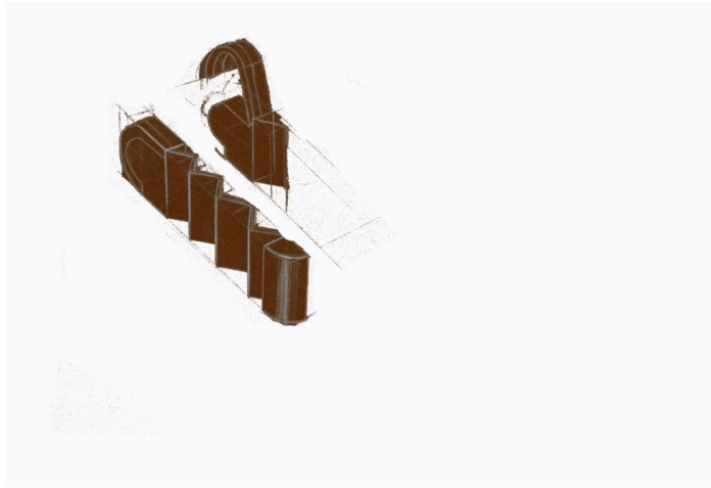

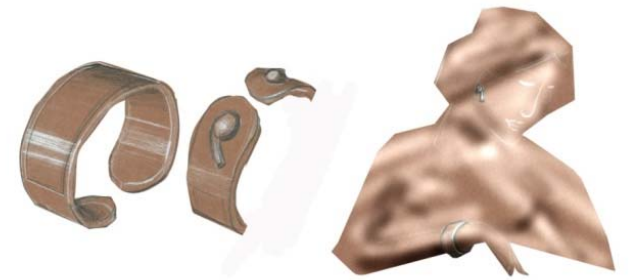
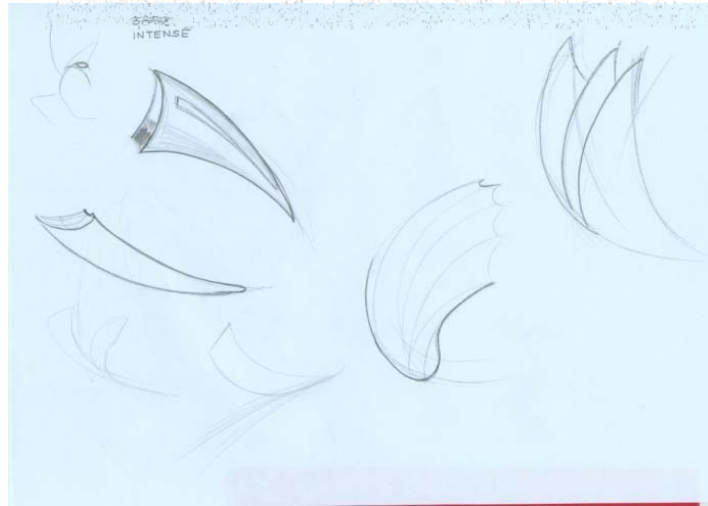
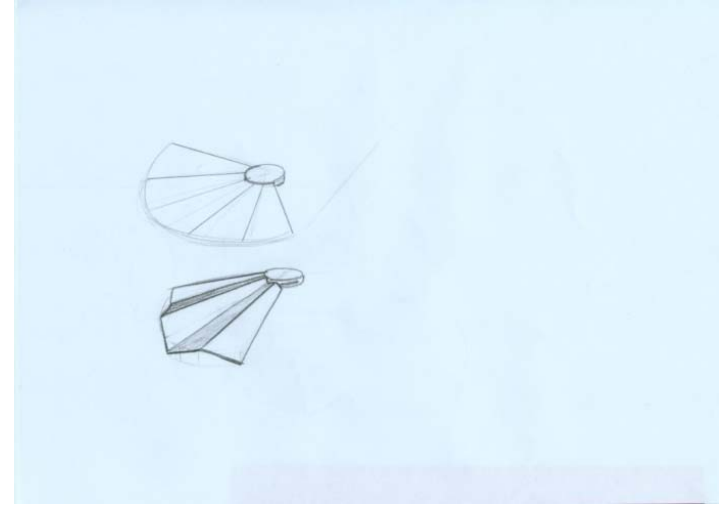
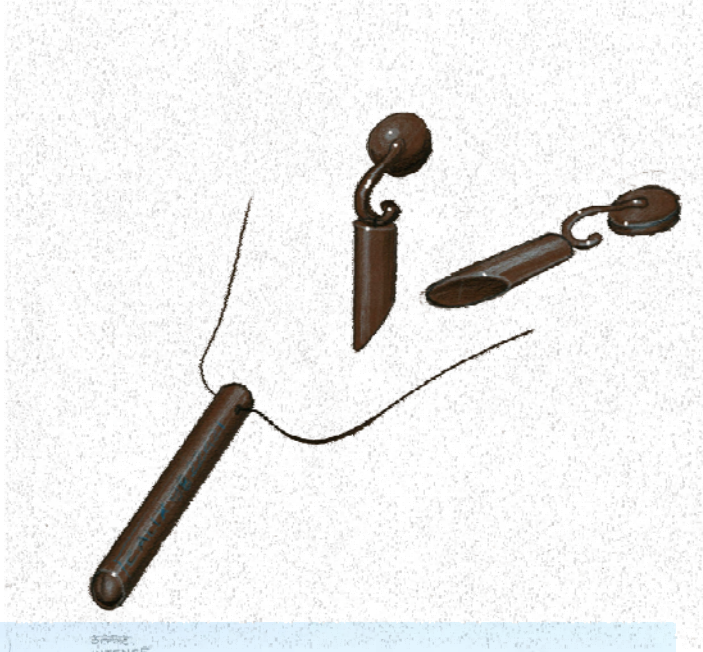
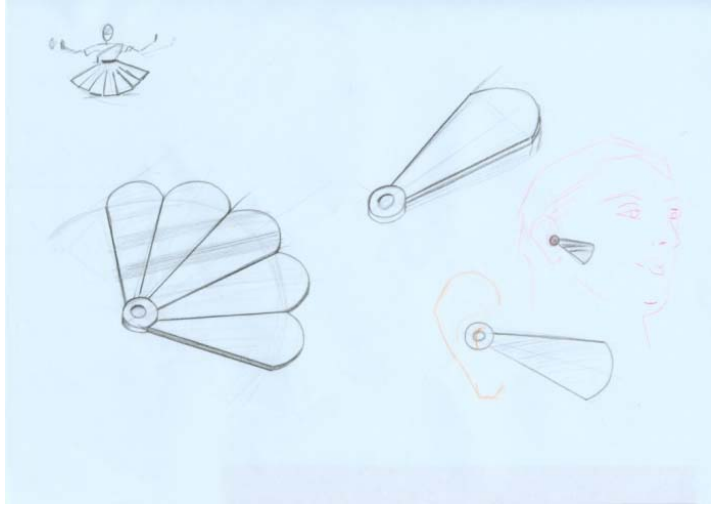

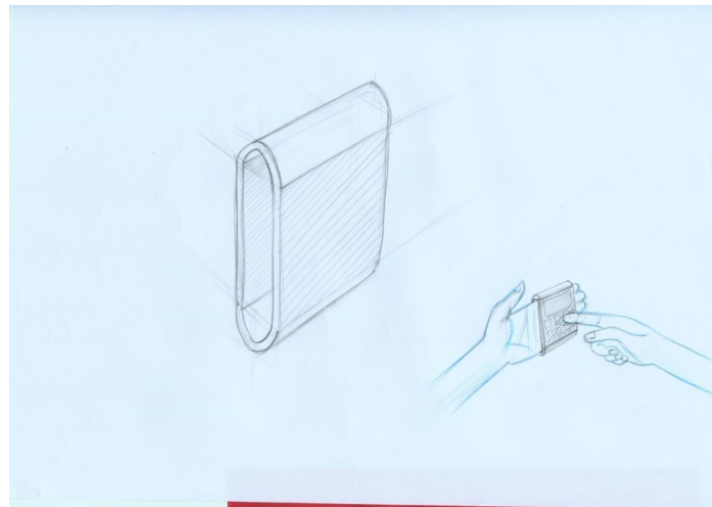
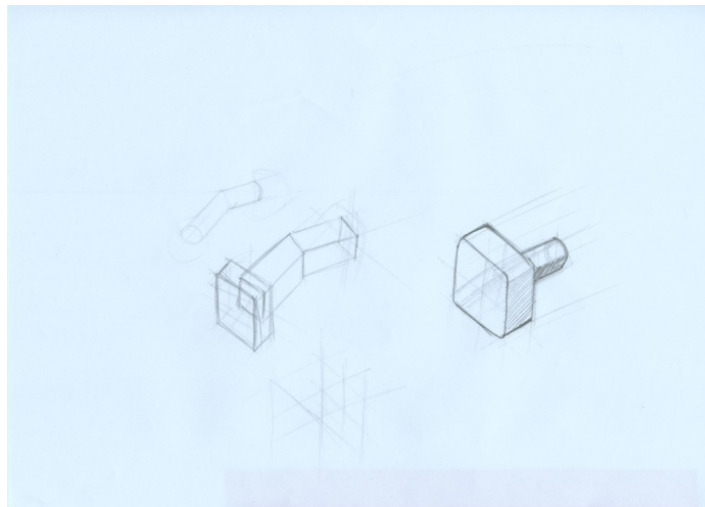
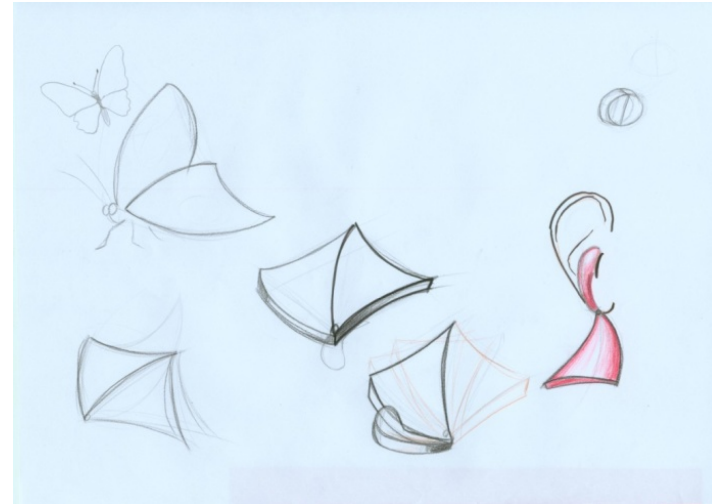
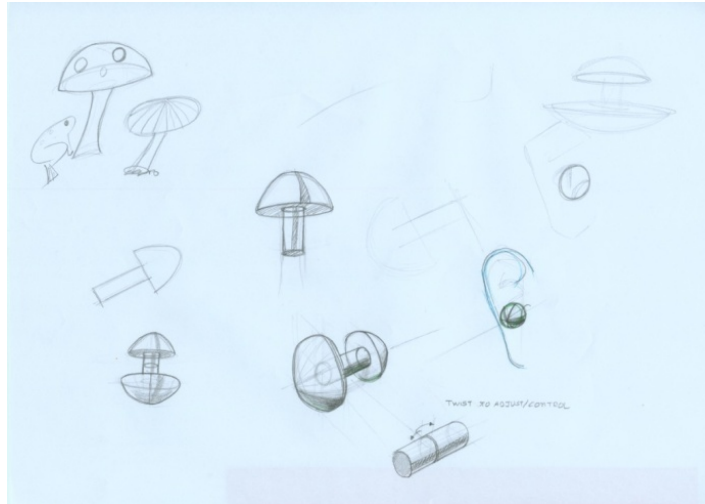
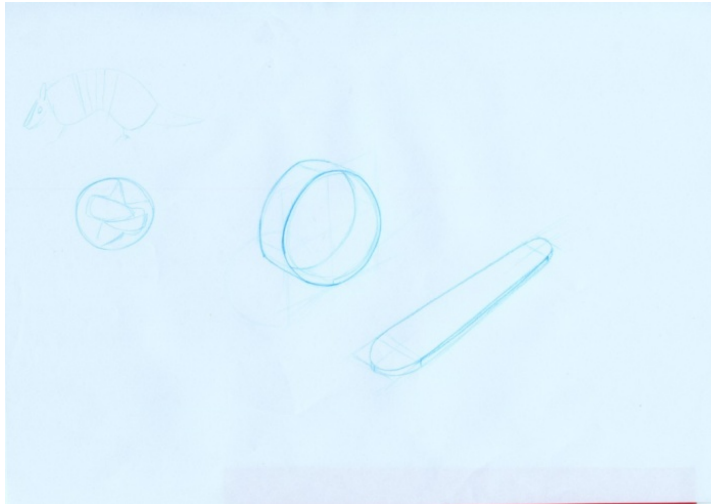

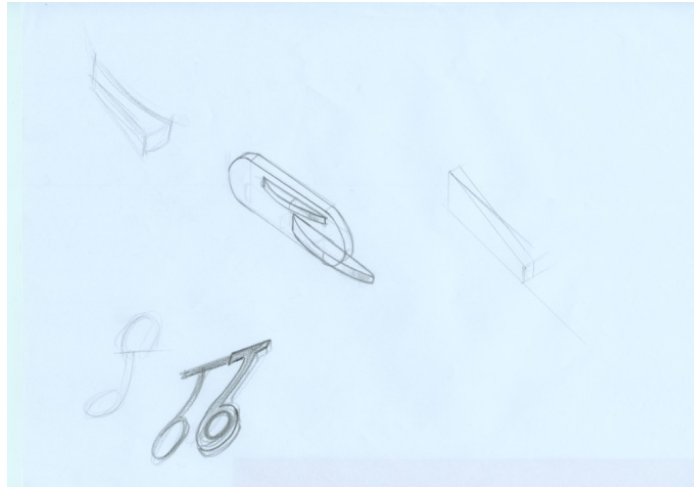
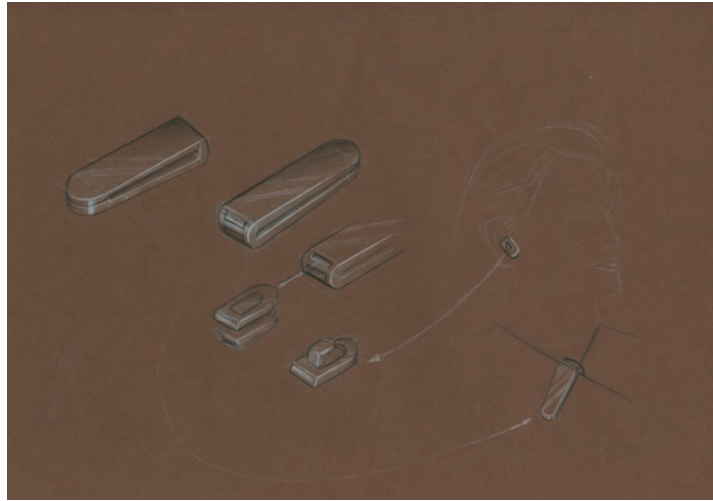

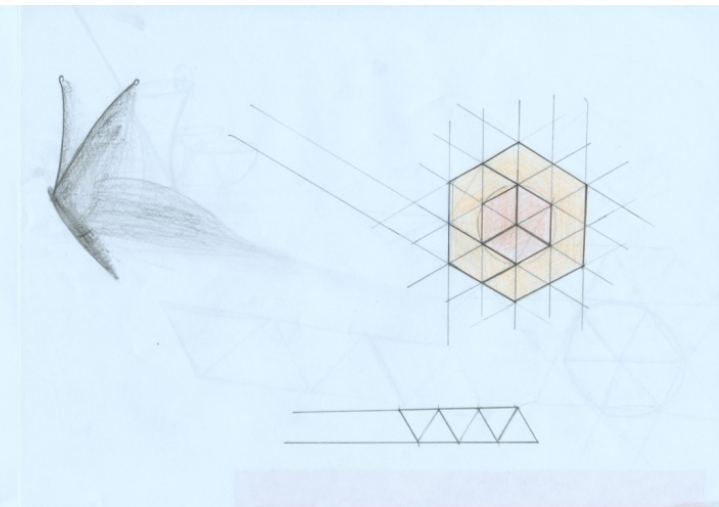
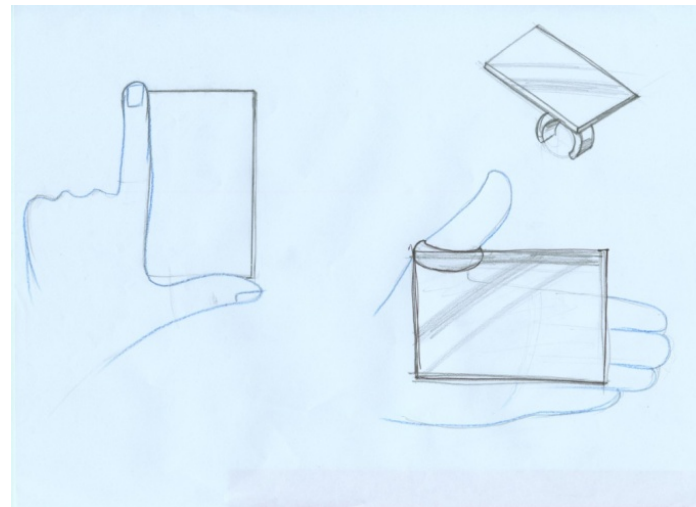
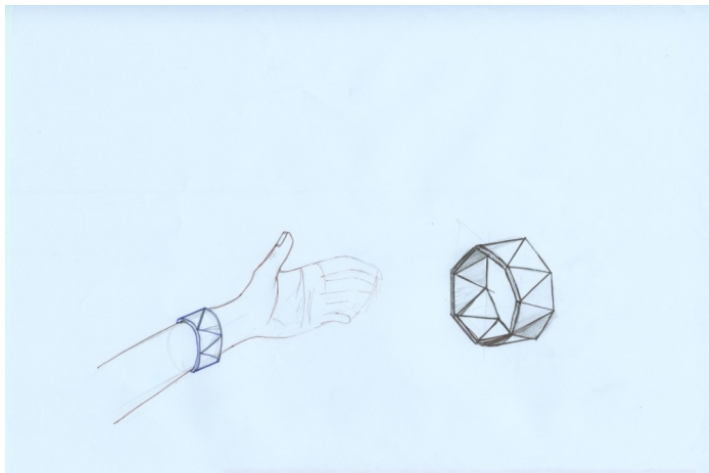
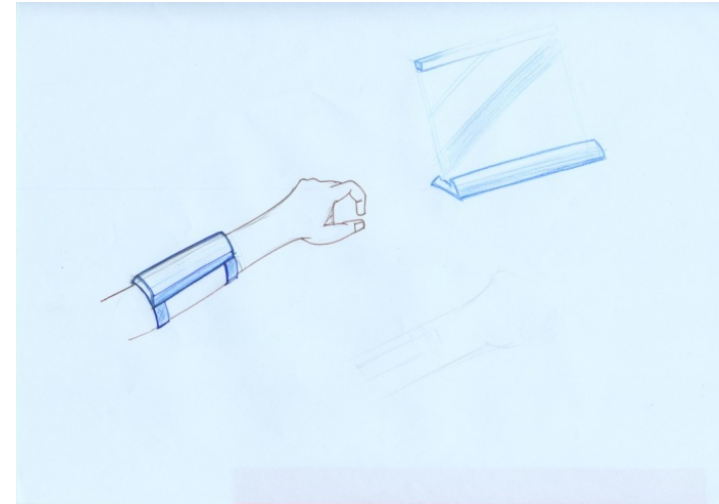
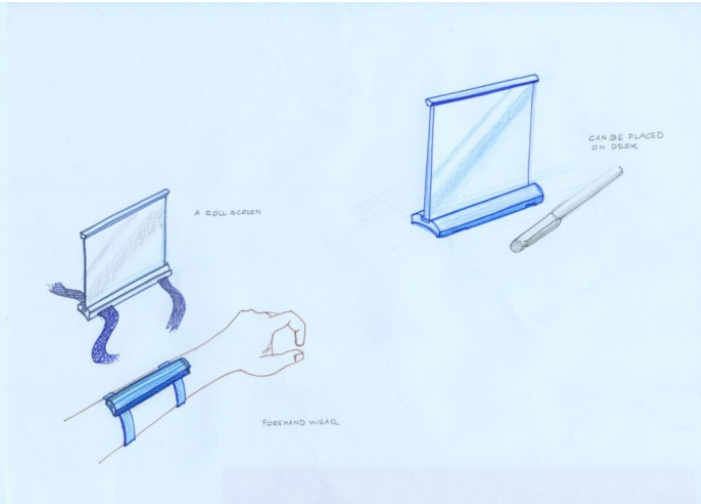
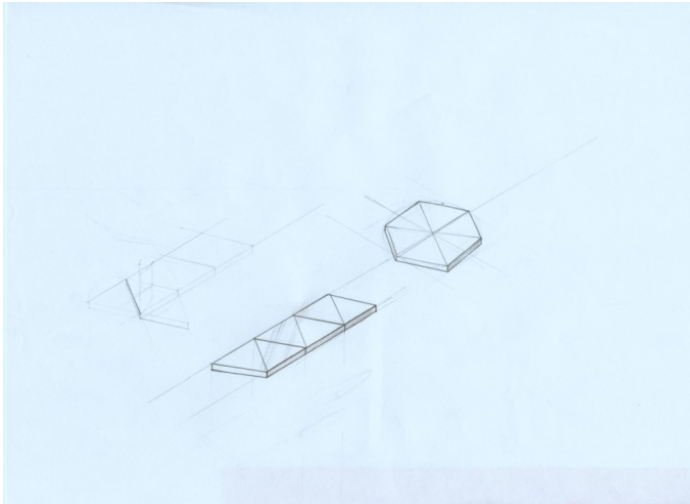

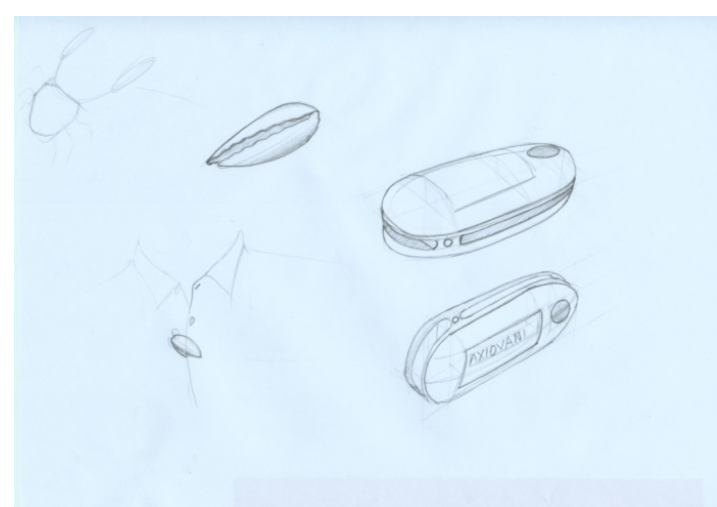
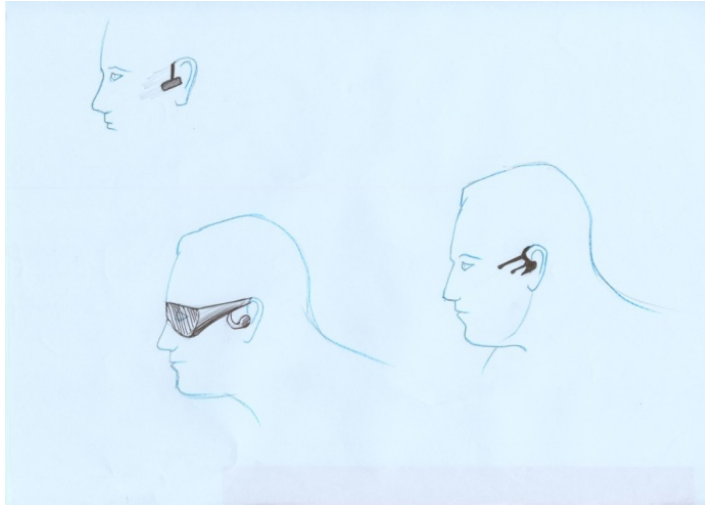
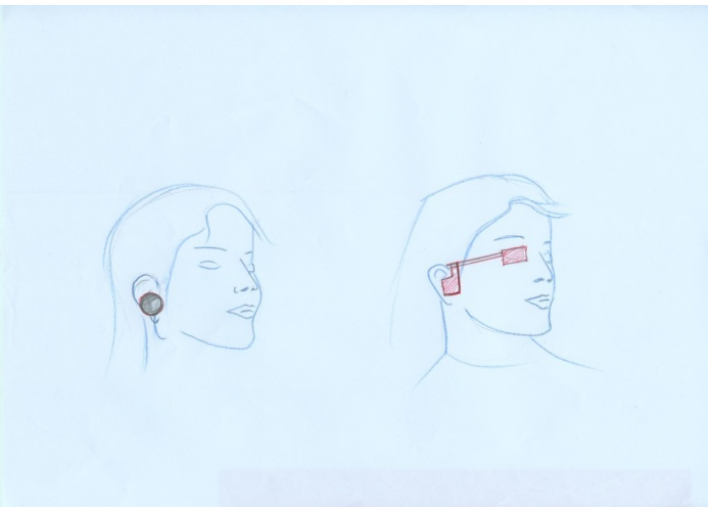
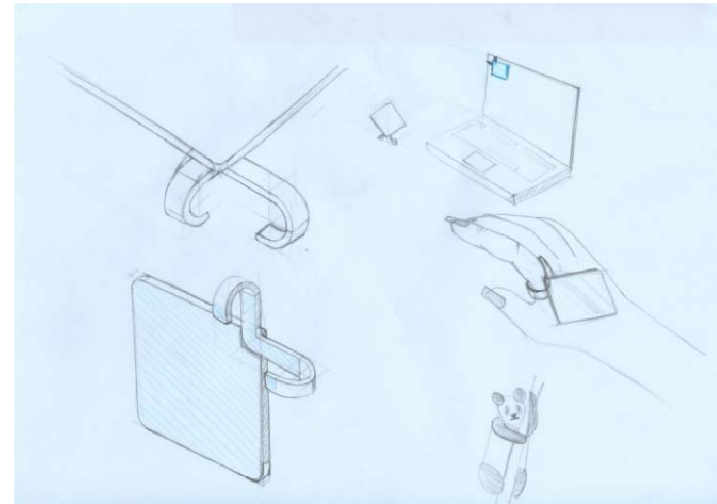

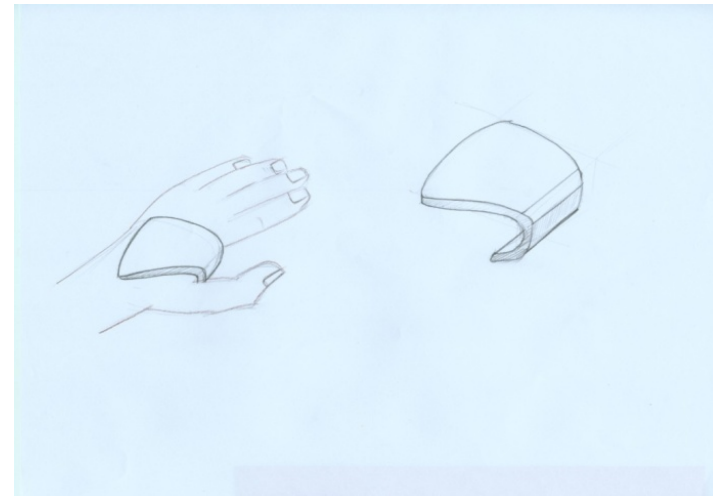
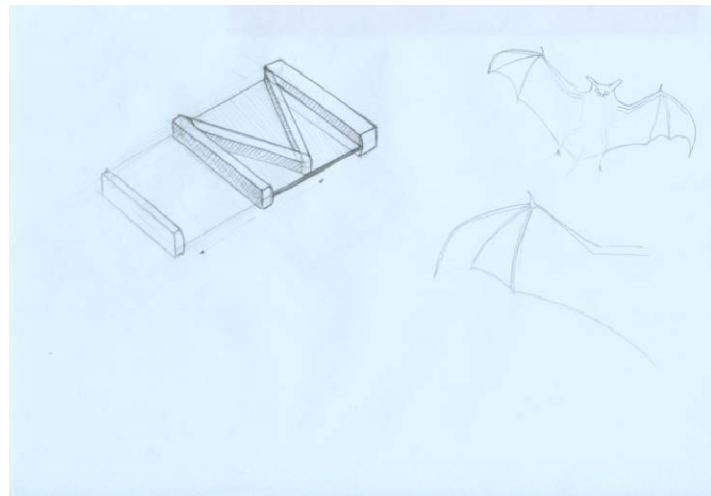
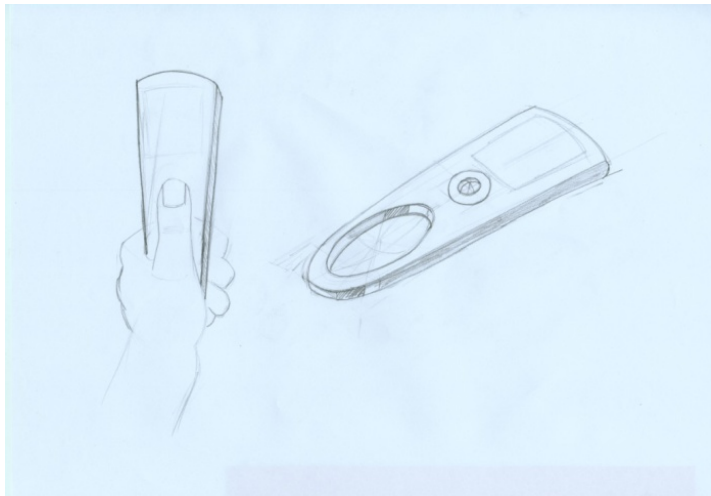
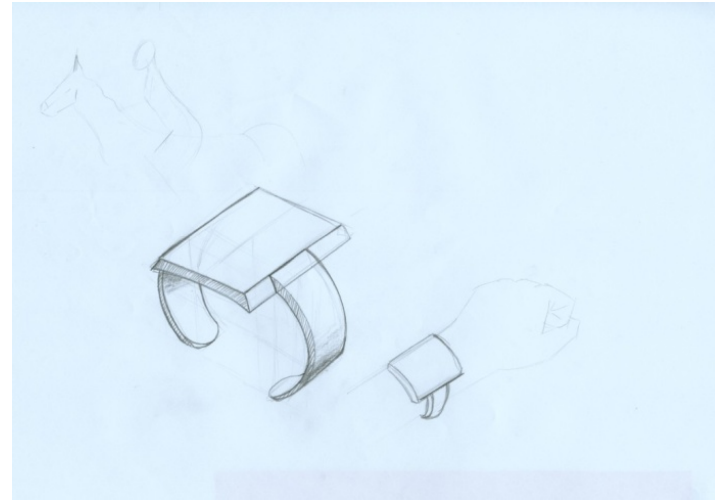
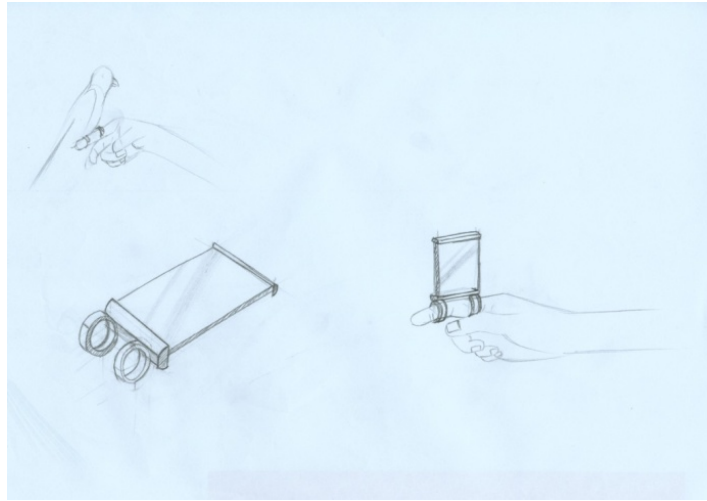
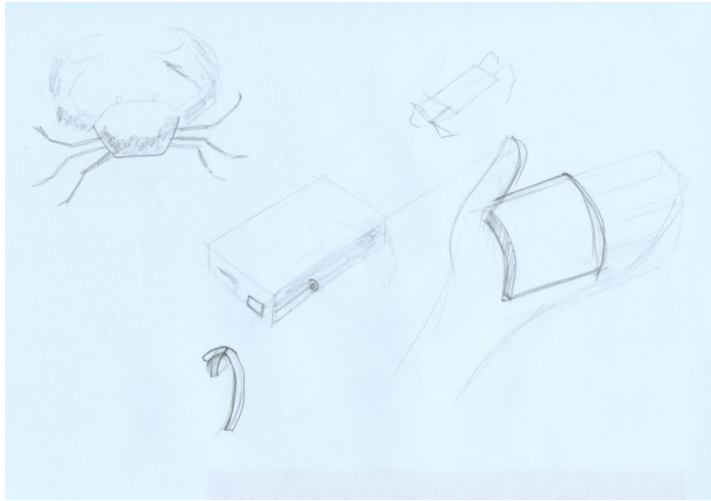

Concept 1

Cluster 1



Cluster Representative

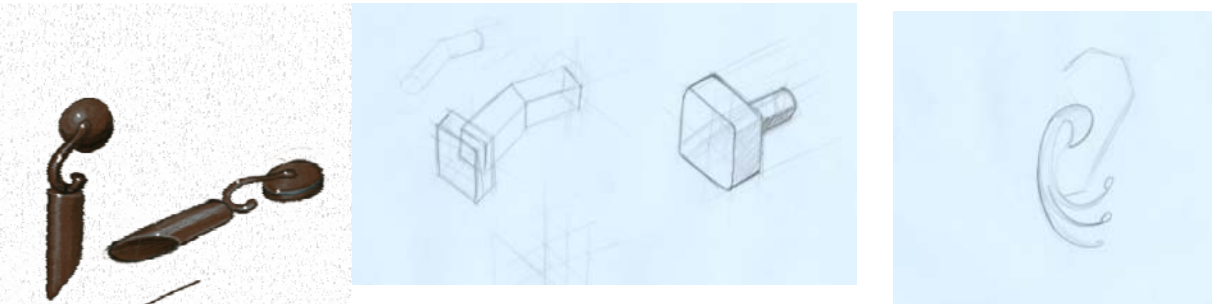

Jewellery look
Feminine

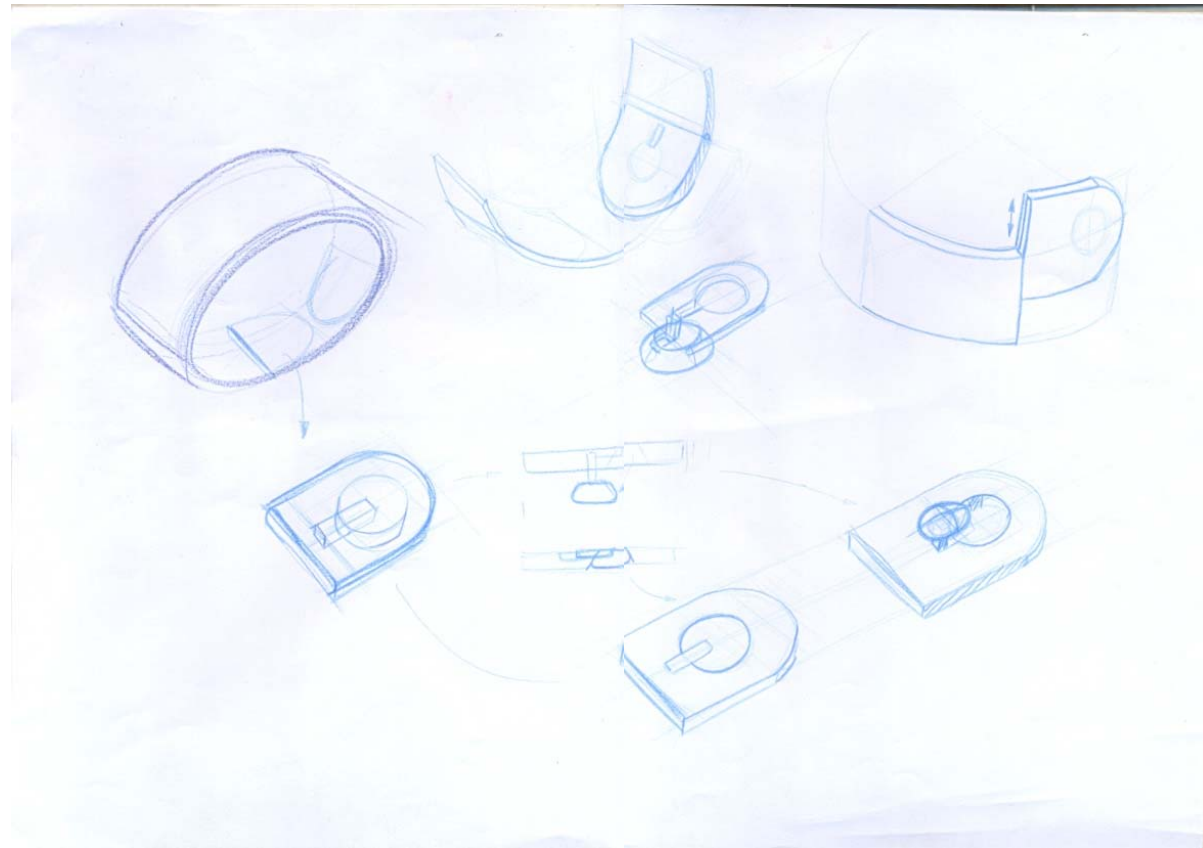
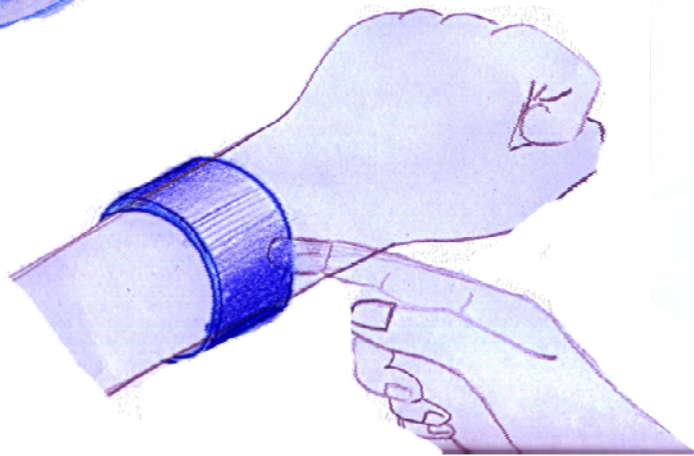
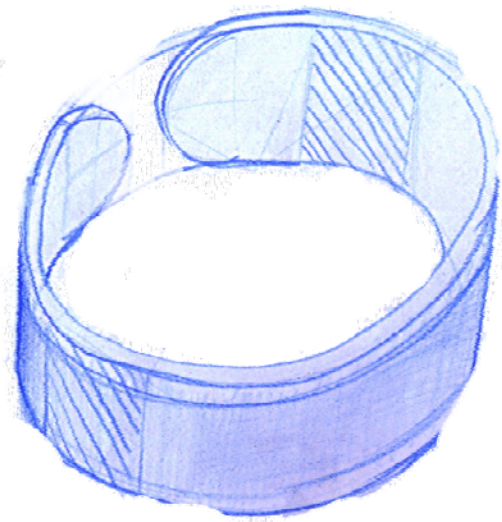

Wrist gear
Flat display

Cluster 1 development

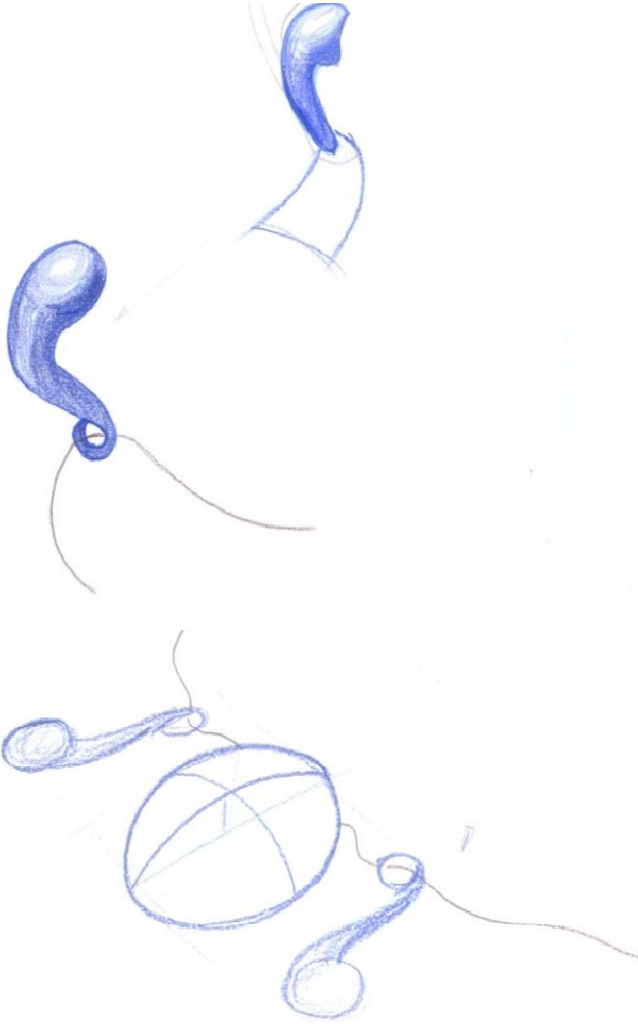
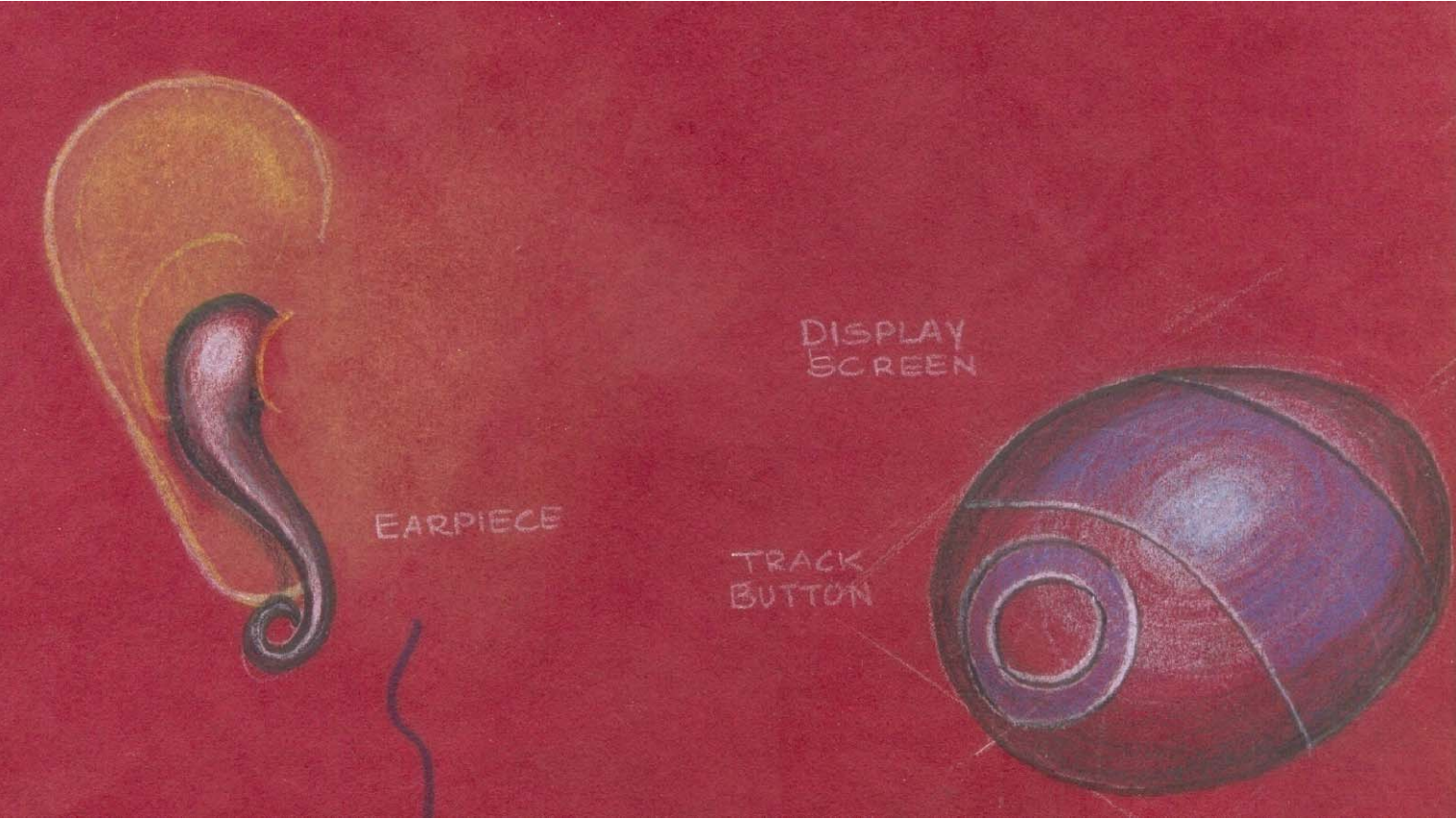

Jewellery look
Feminine

Concept -1

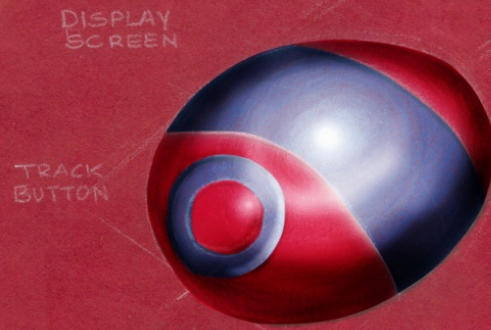
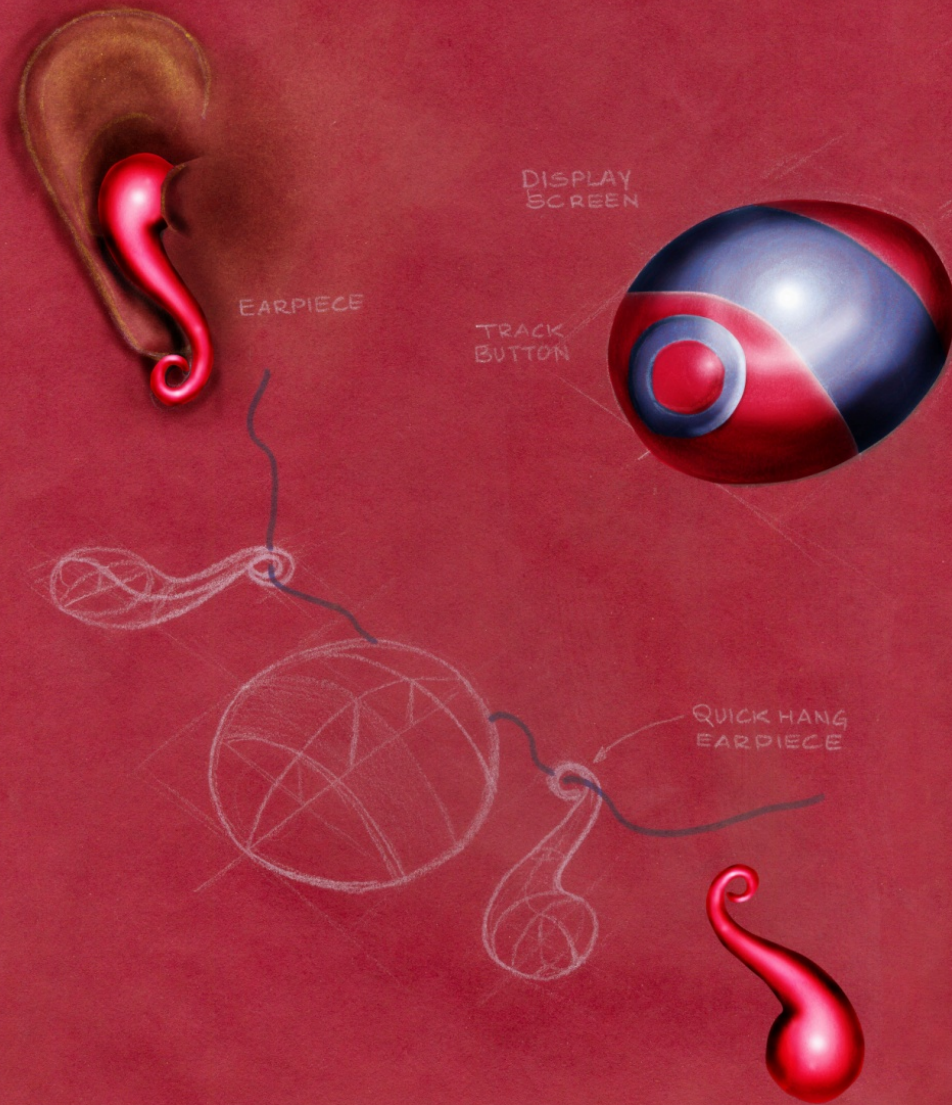

CONCEPT-B

Concept -1

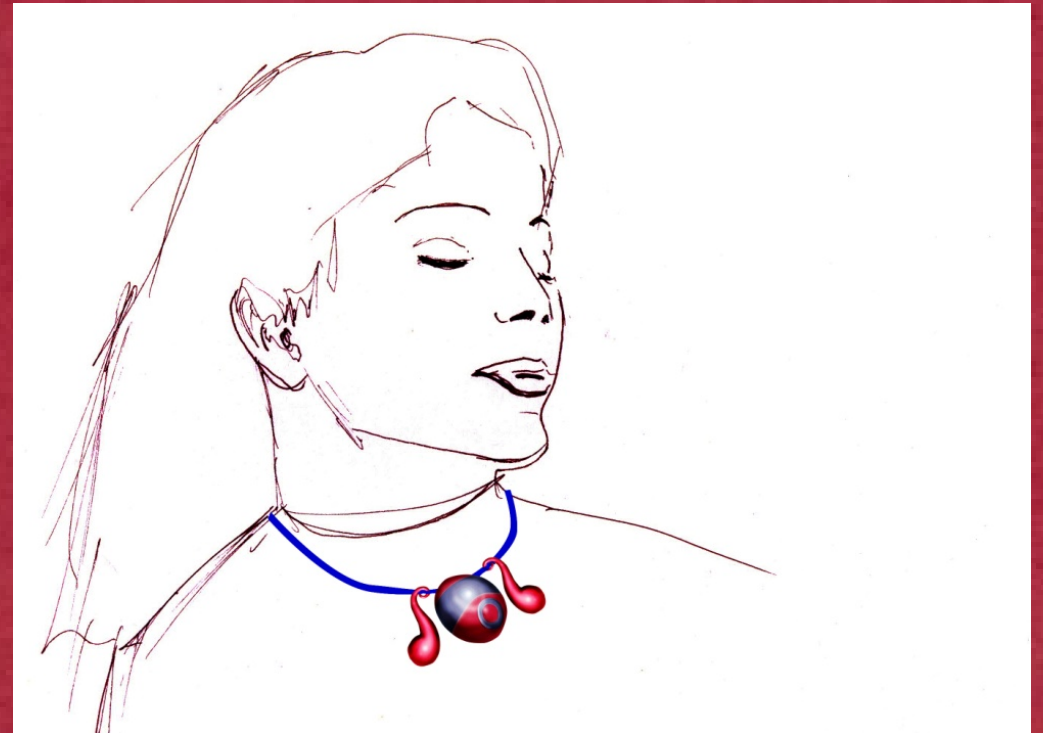
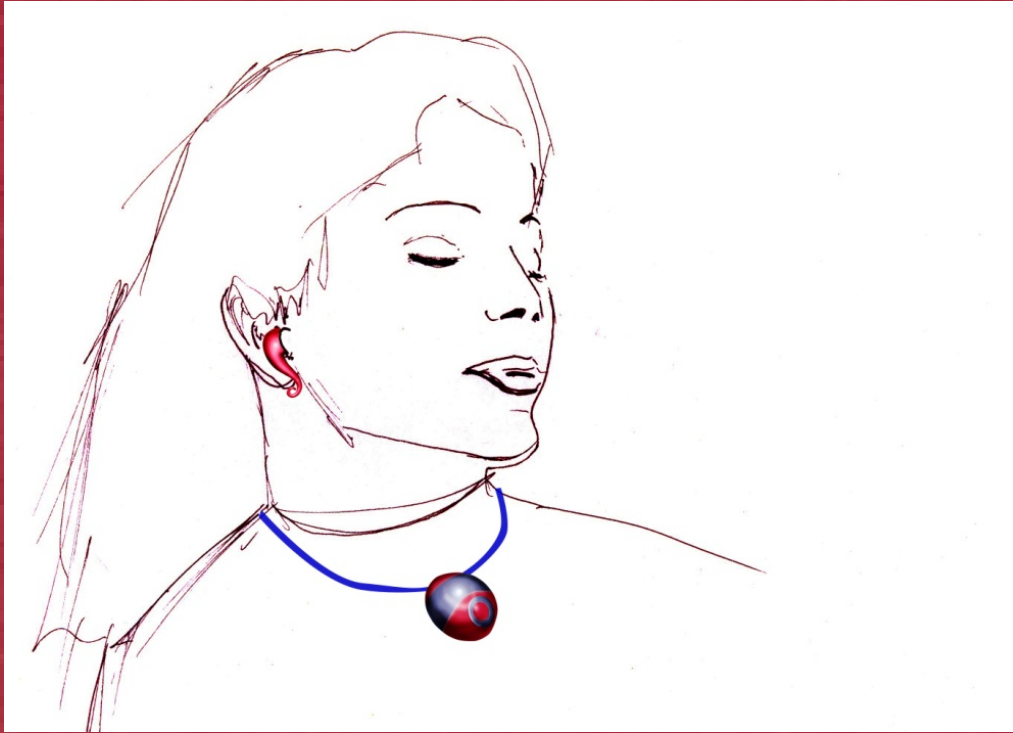

Feminine
Elegant
Style

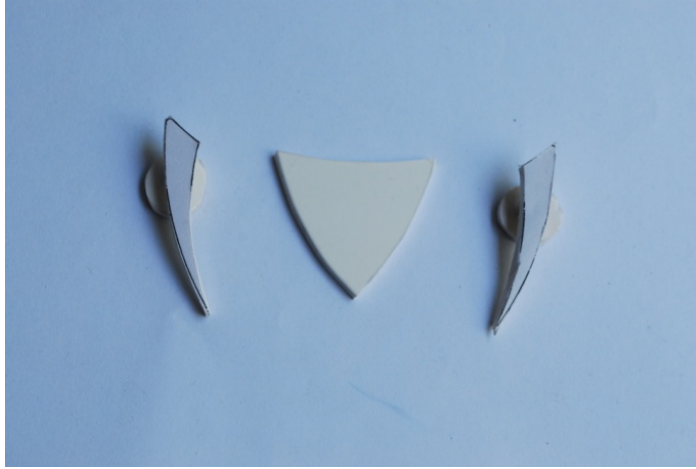
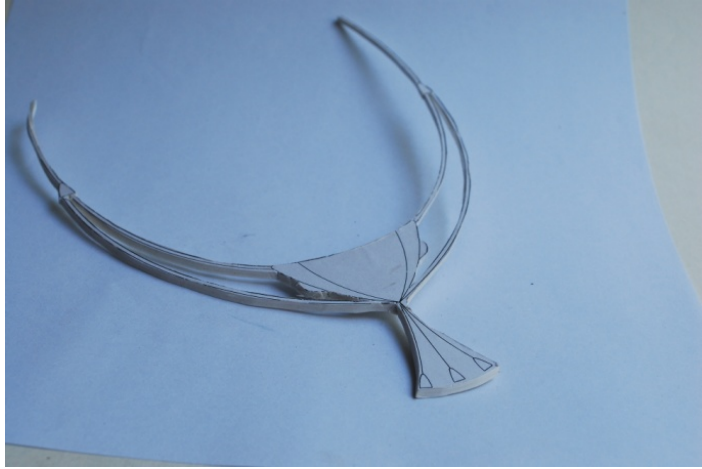







Pendent &
Detached earpieces



Earpiece



Pendent without earpieces

Concept 1

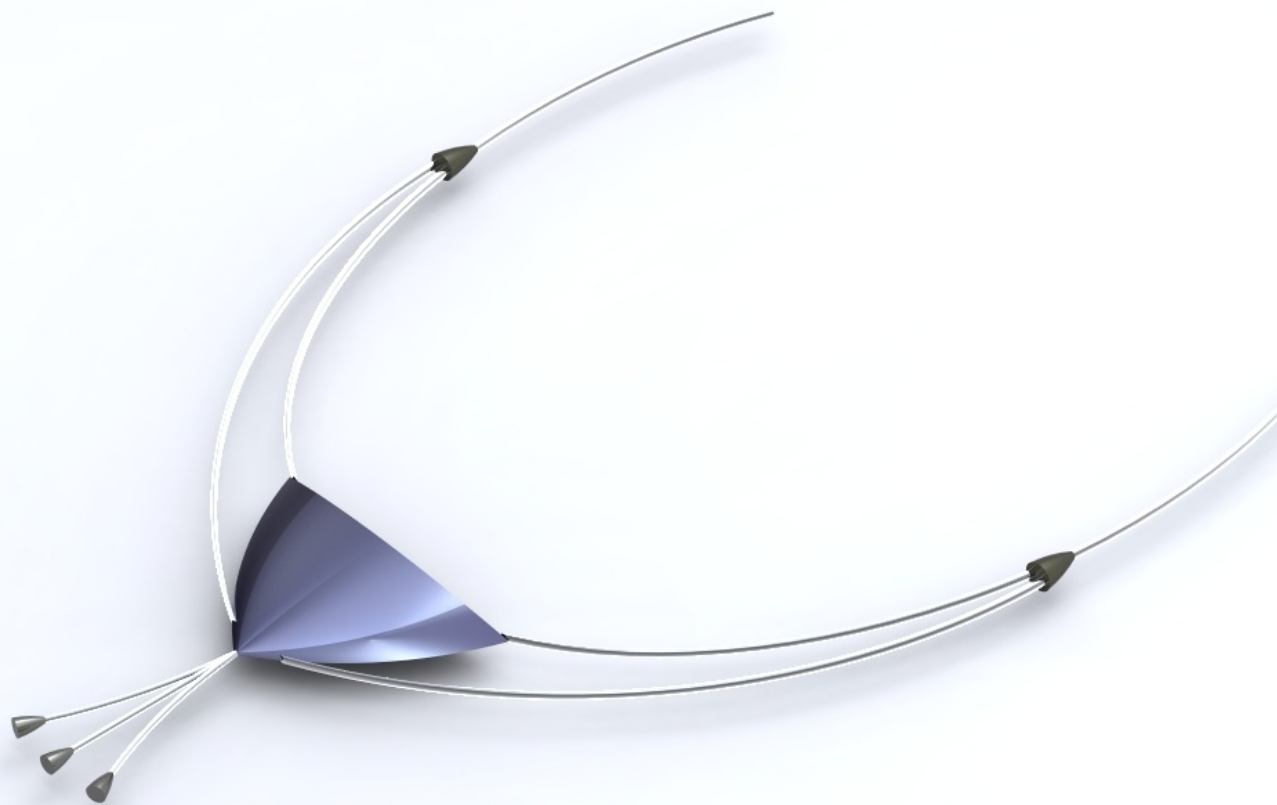

Dimensional details

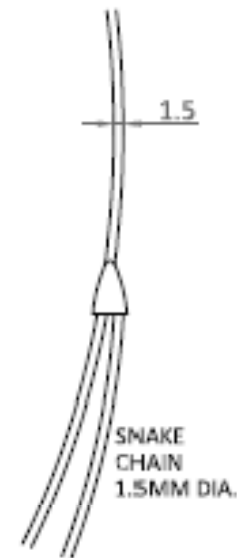
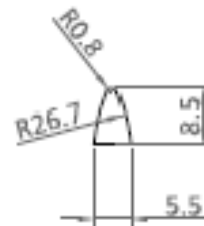
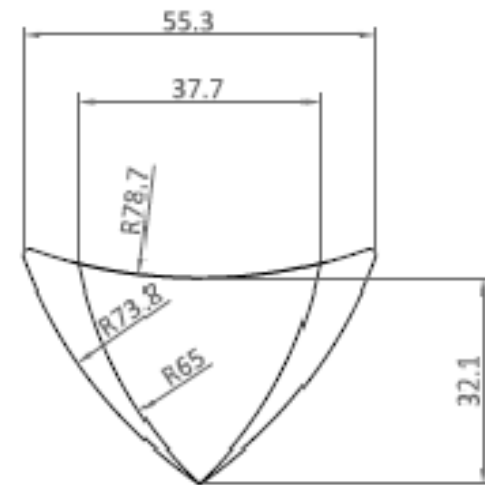

CONCEPT 1





Concept 2

Cluster D

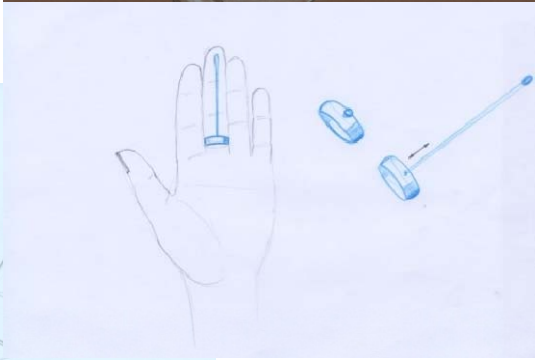
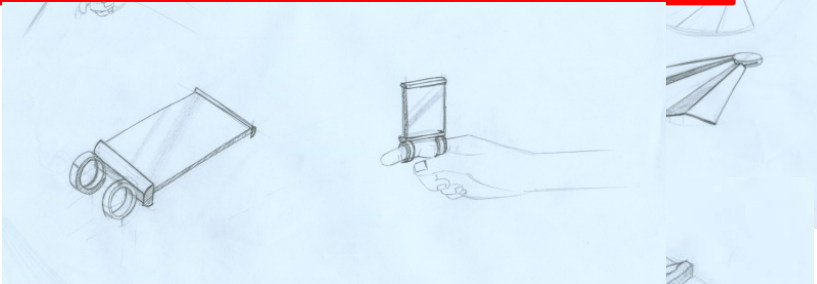
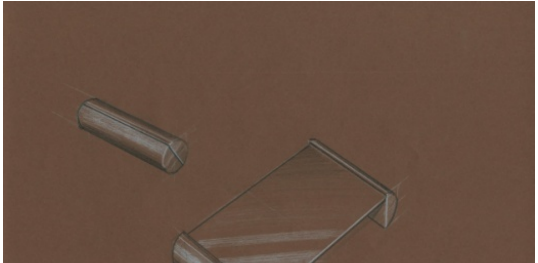
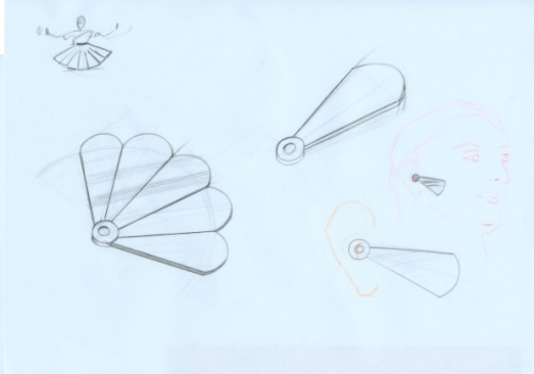
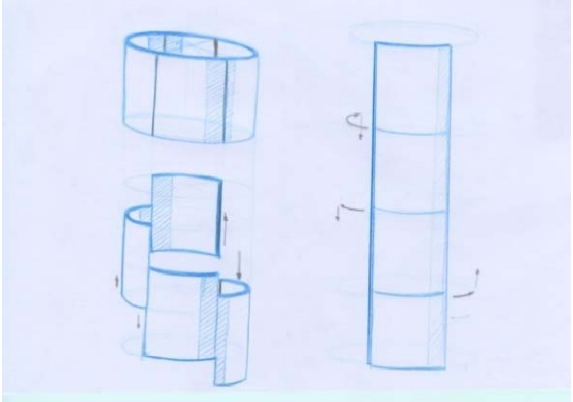
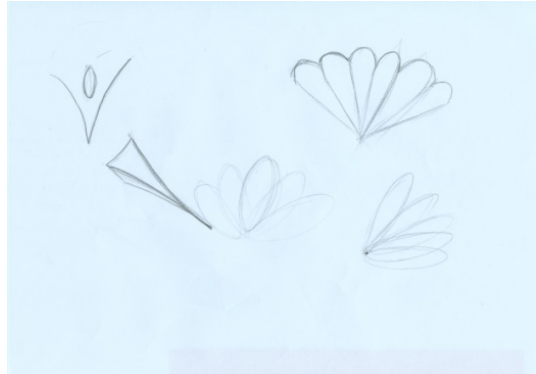
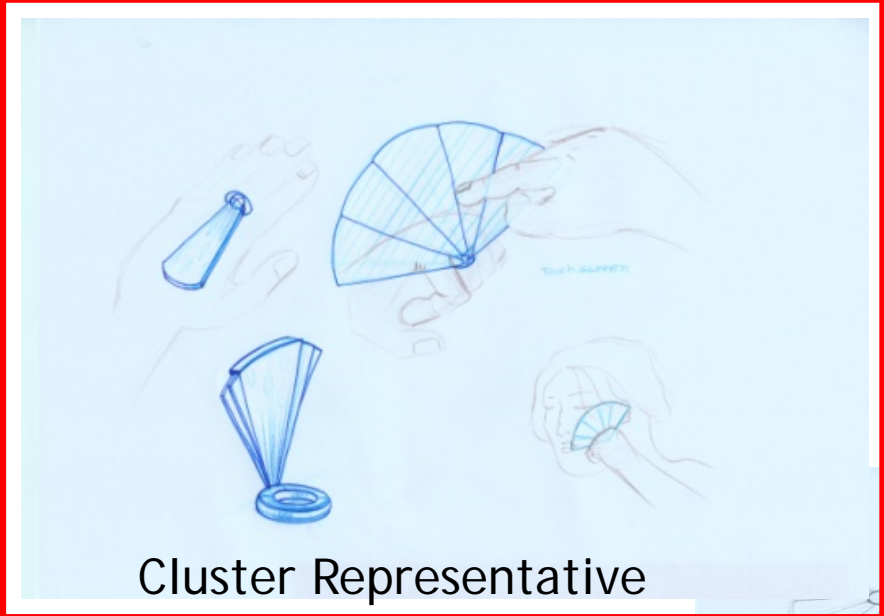

Collapsible
Big screen
Radical form

Cluster 2 to Concept 2

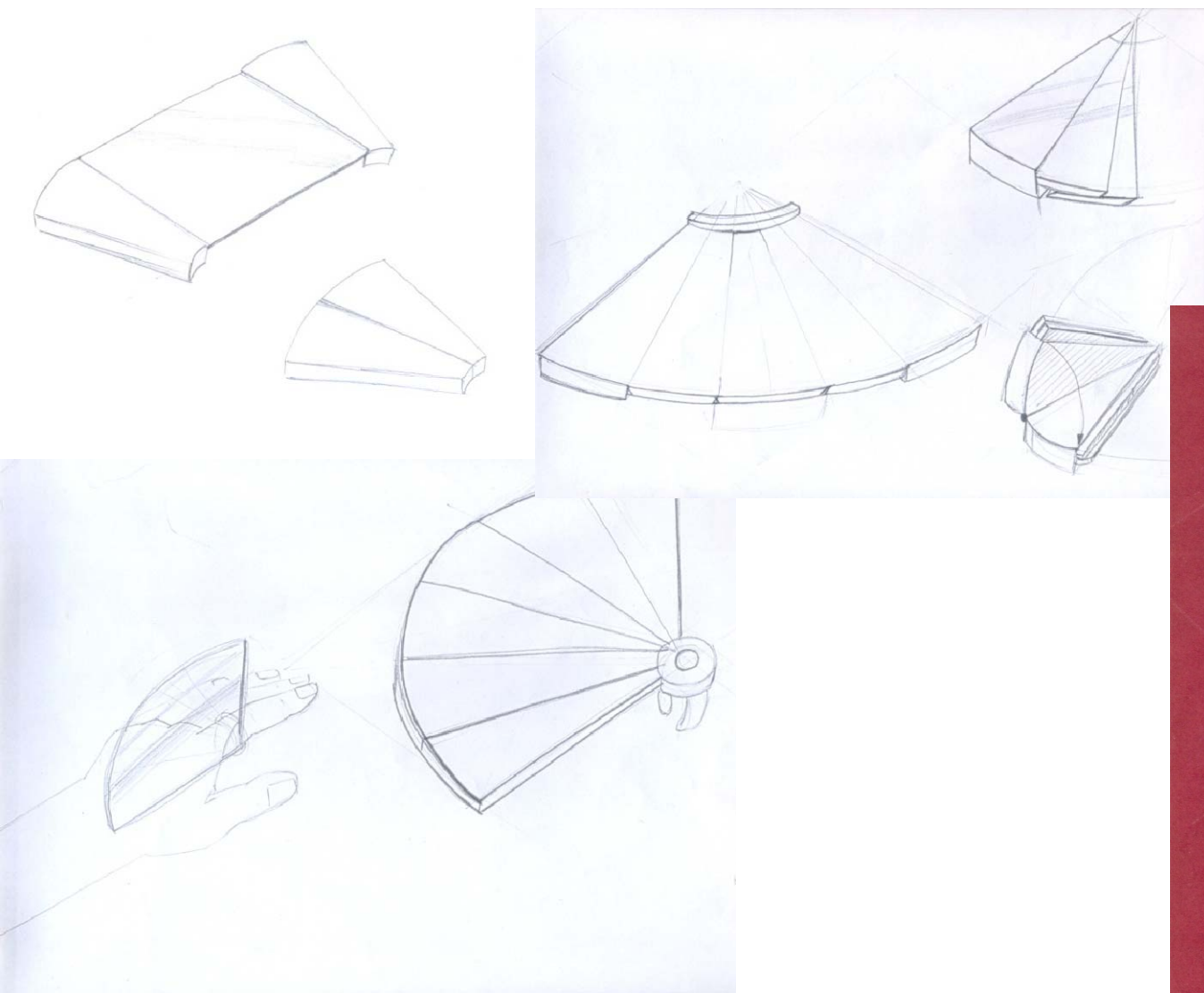

Collapsible
Big screen
Radical form

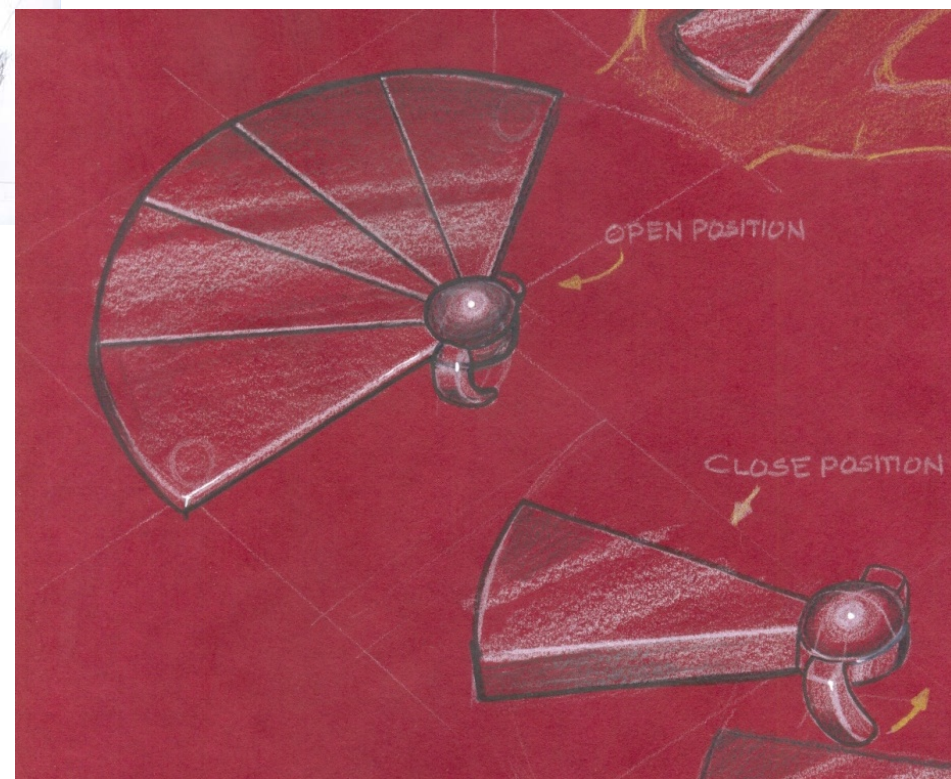

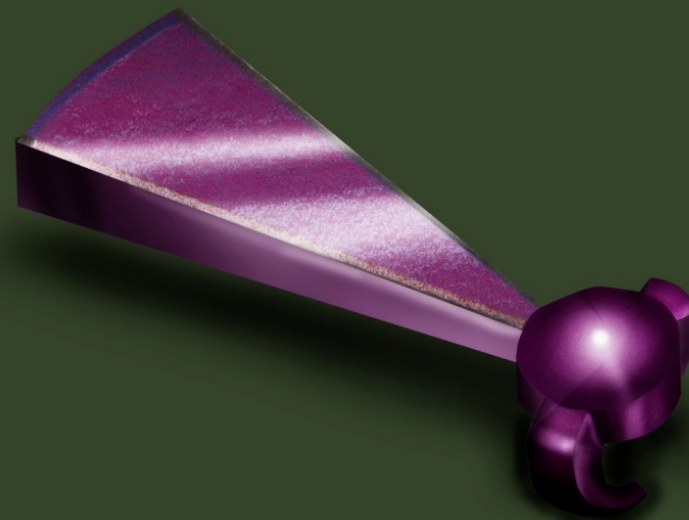
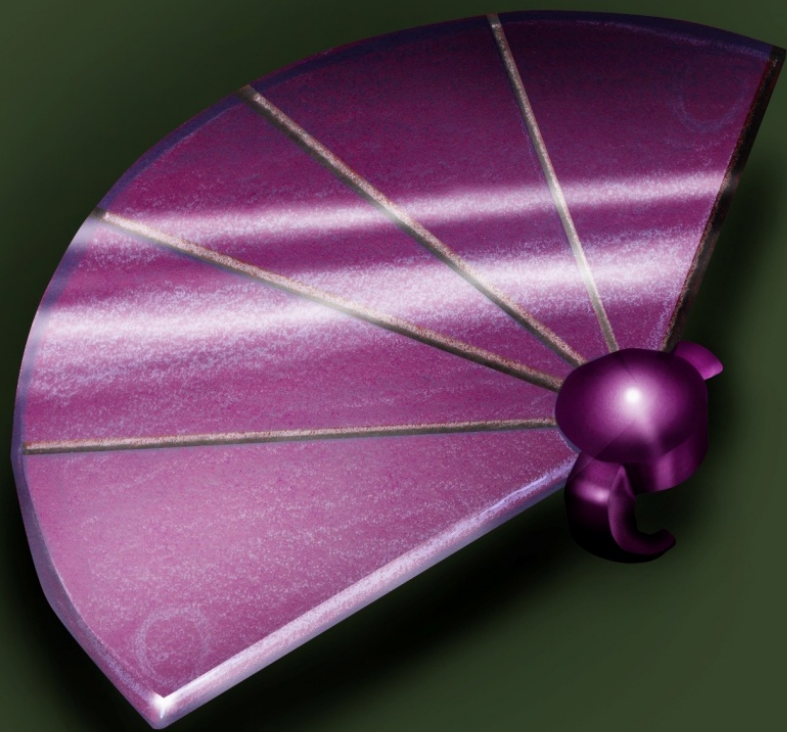

Trendy
Techie
Unisexal

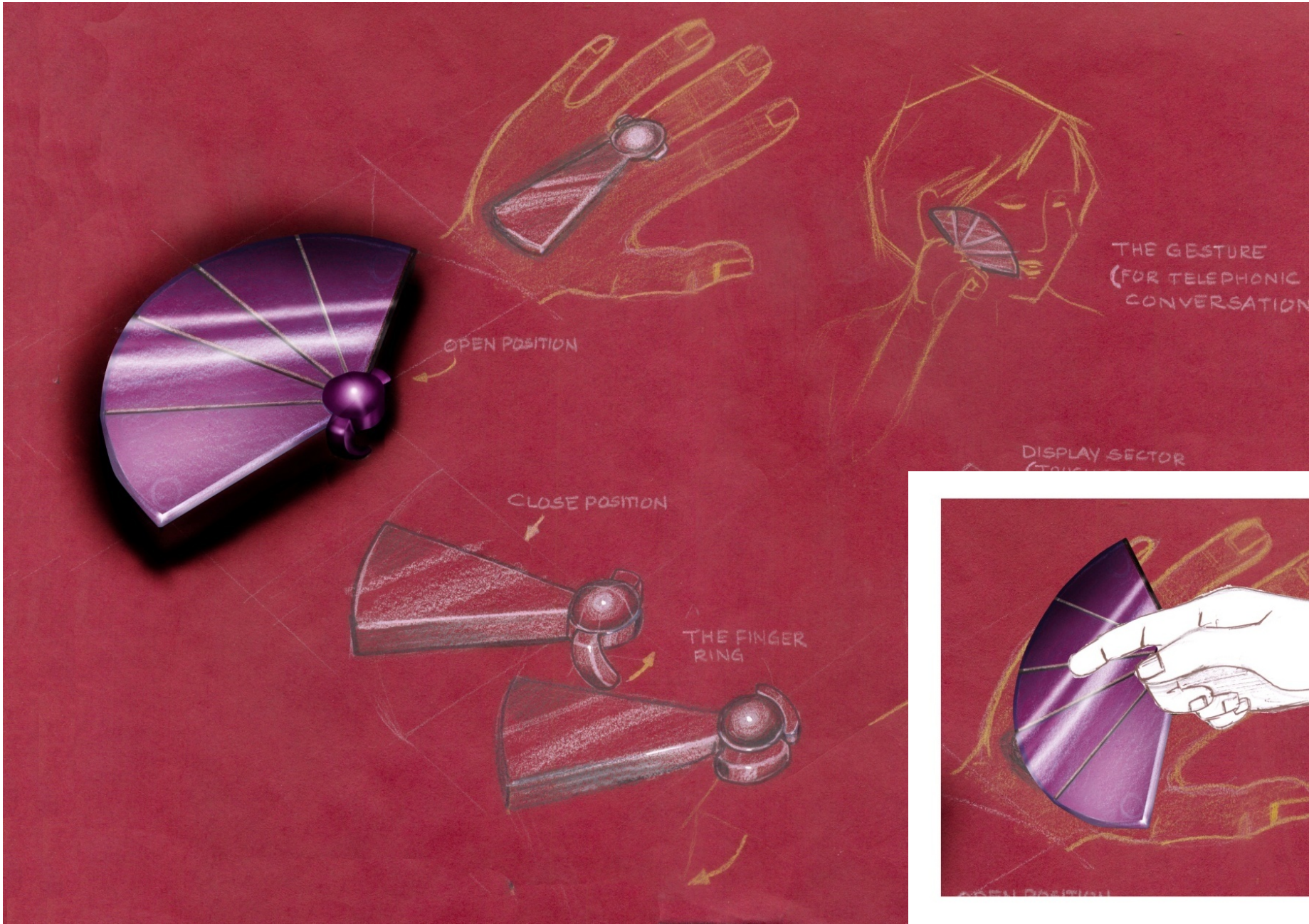

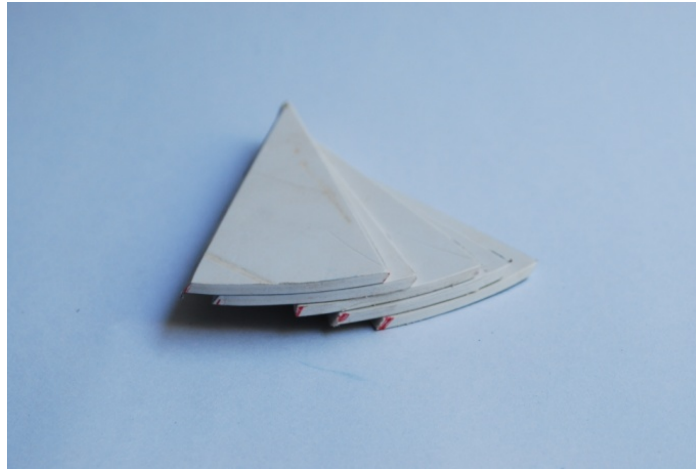
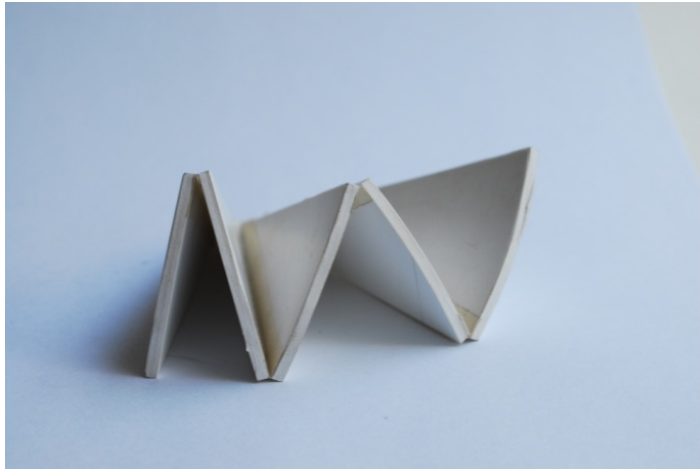
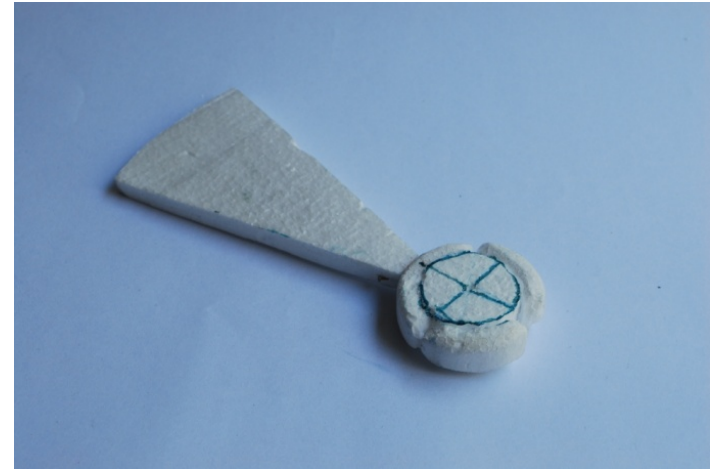
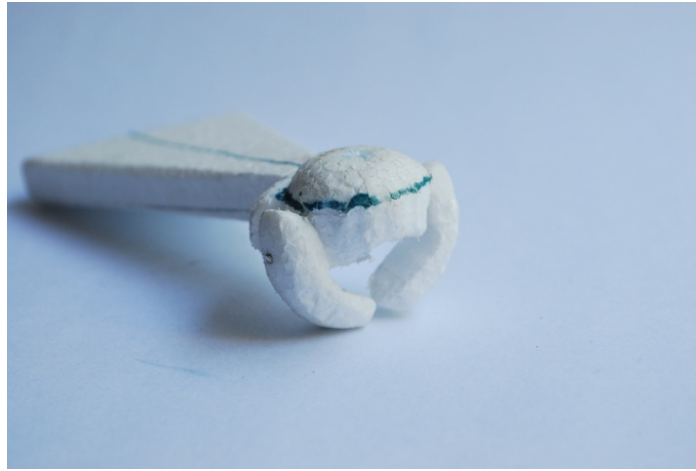

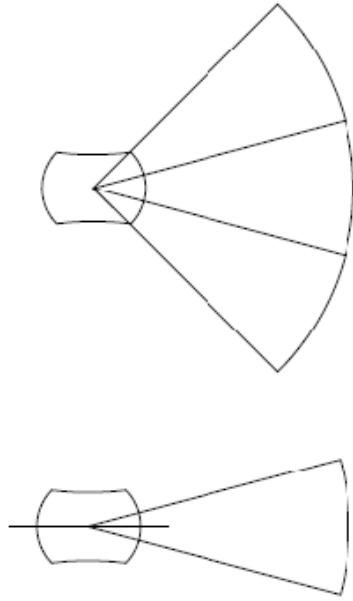
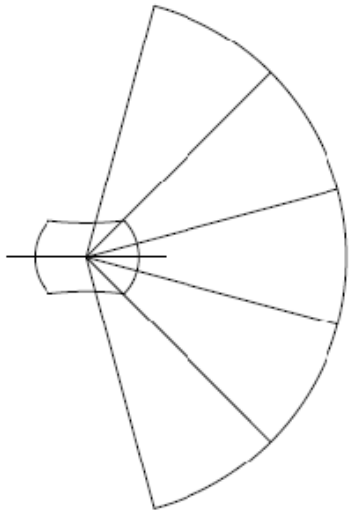

CONCEPT 2

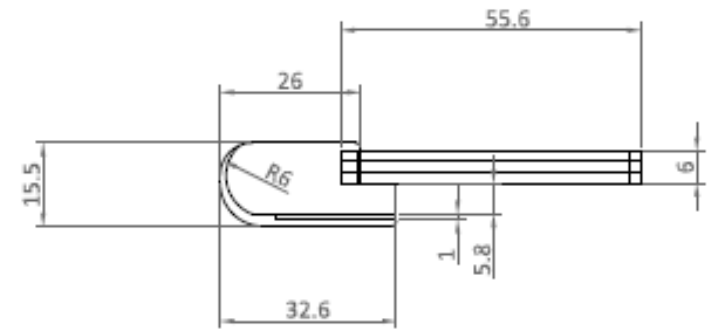
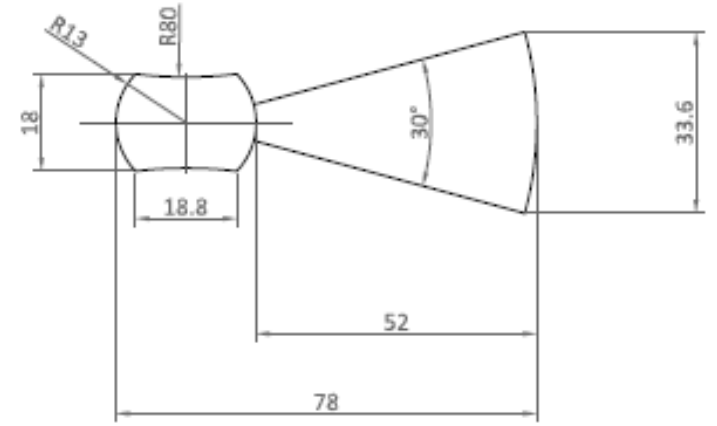

Concept 2

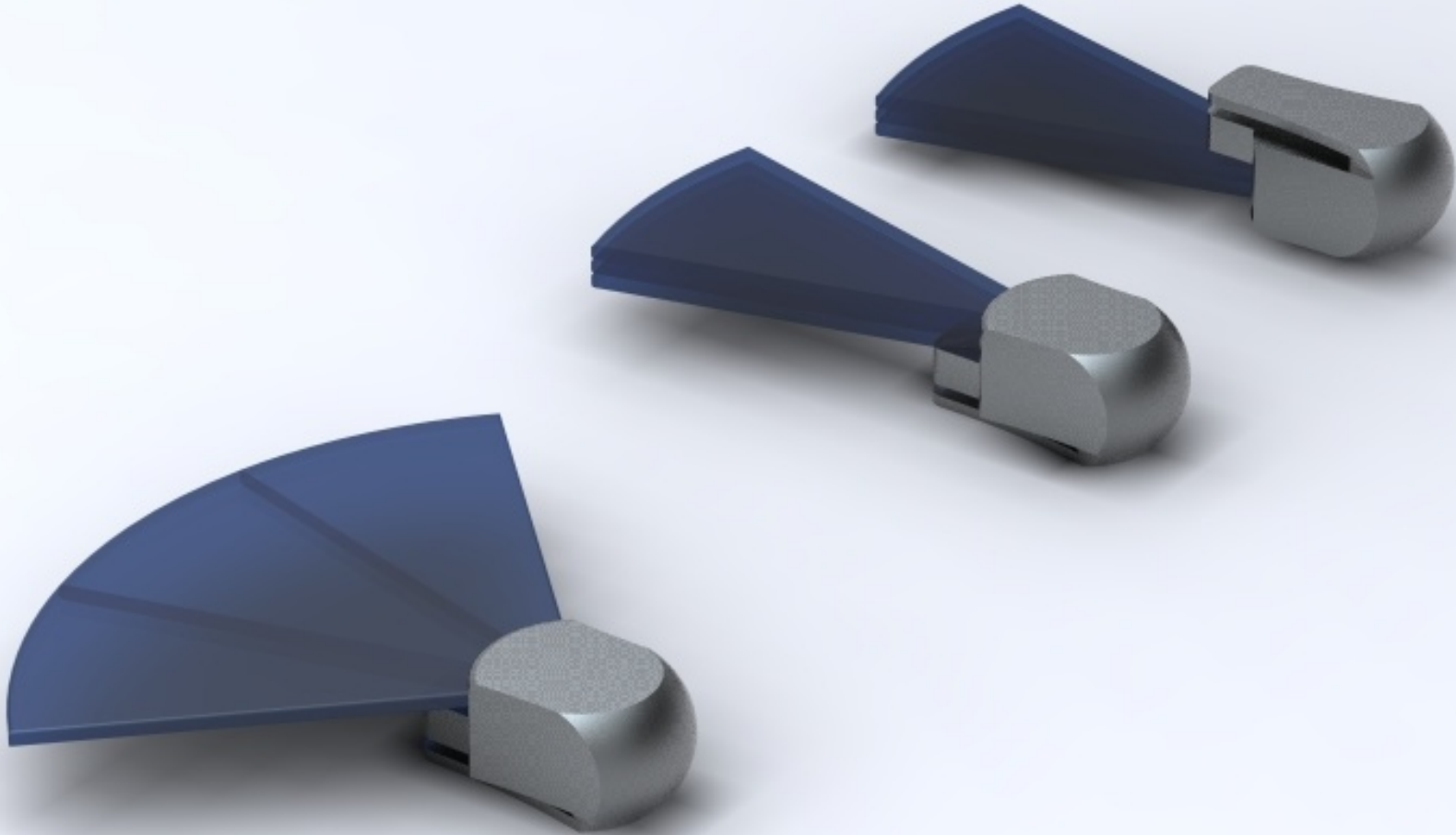



Closed condition
Clips on blazer collar/ shirt

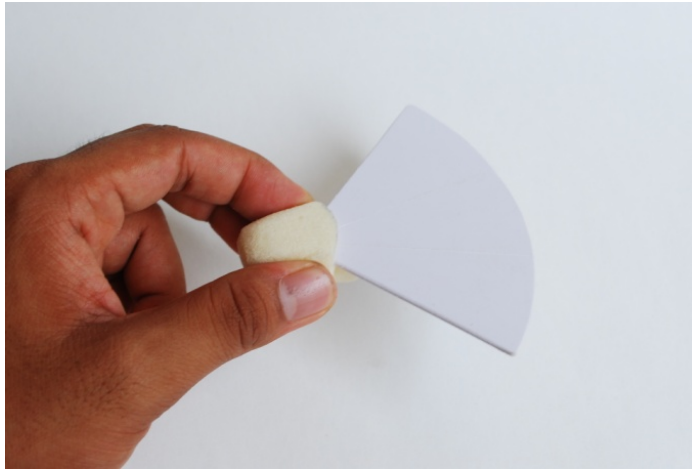

Open position

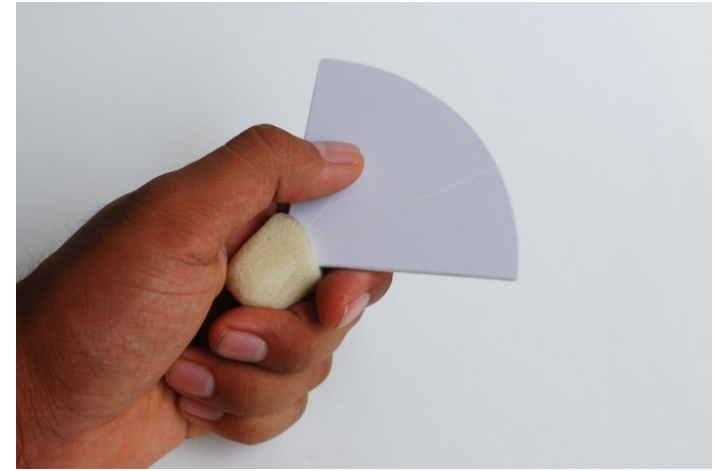

Wide sector touch screen display
Thumb operated

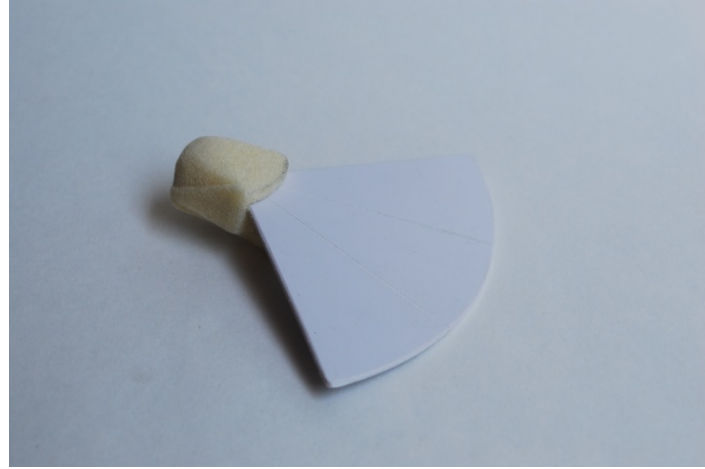
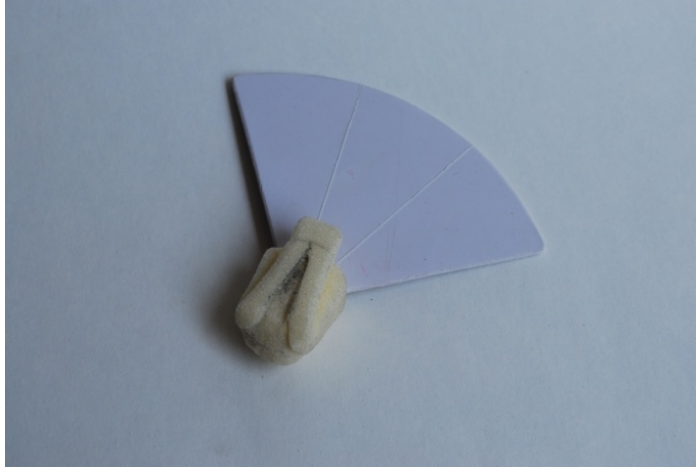
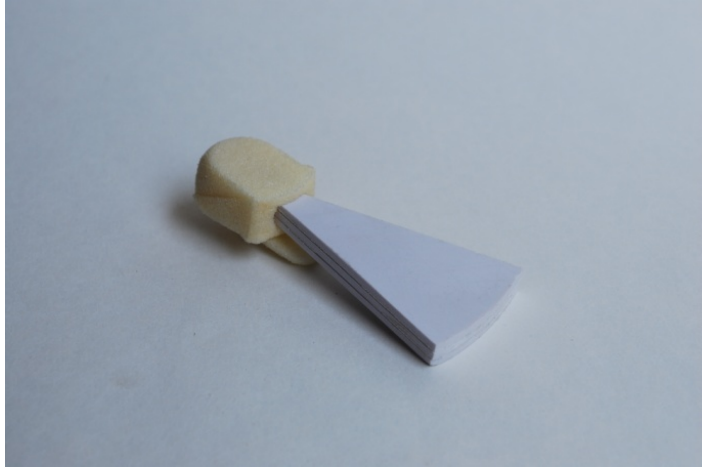

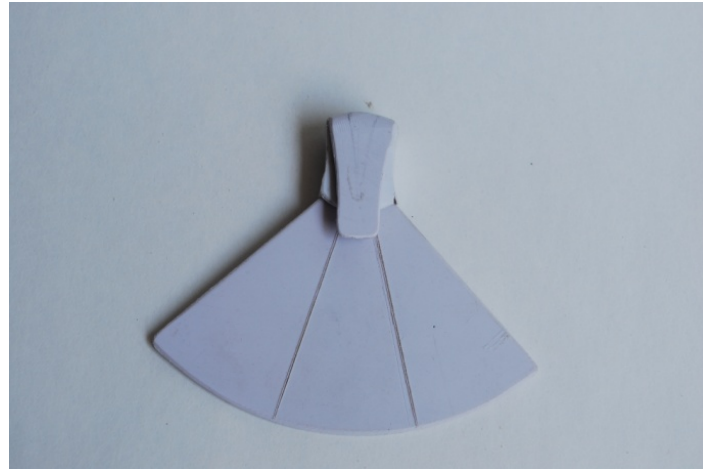
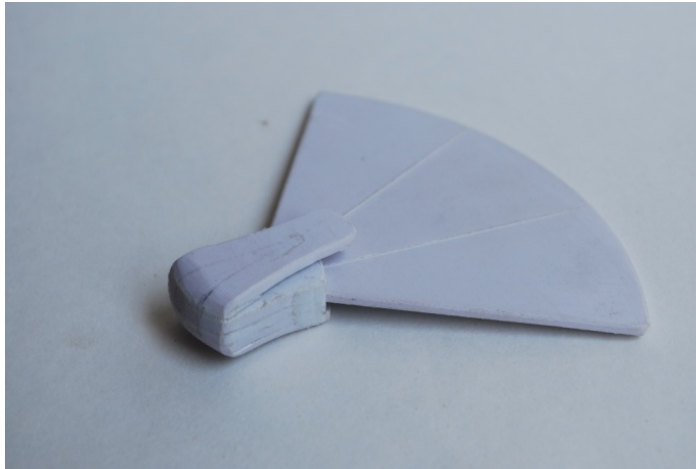
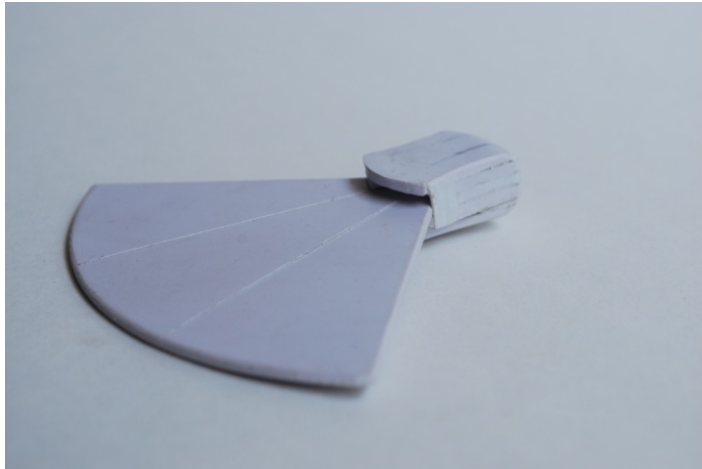
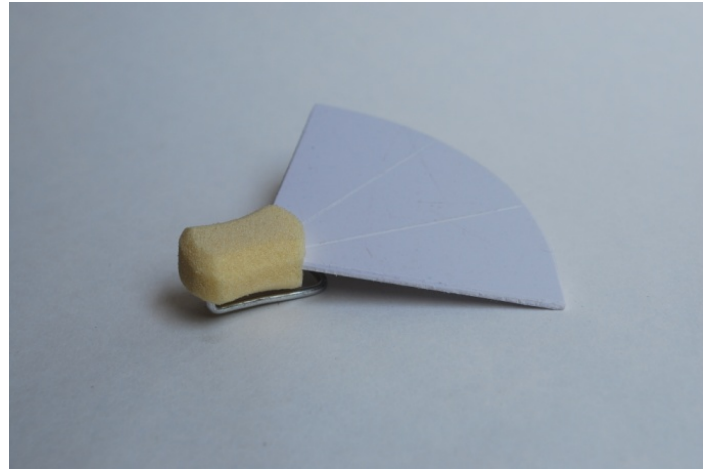
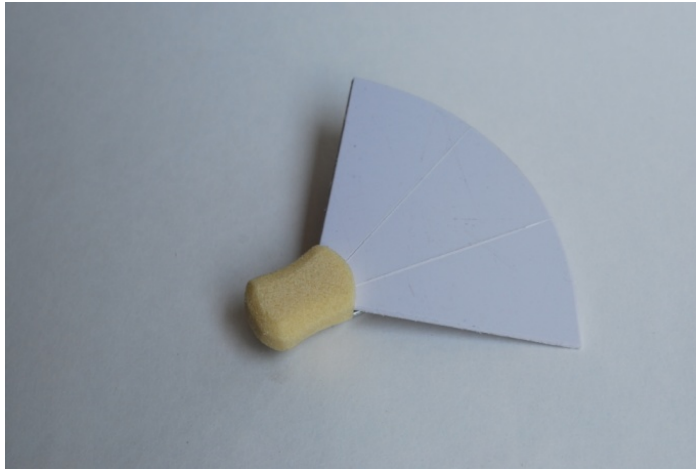
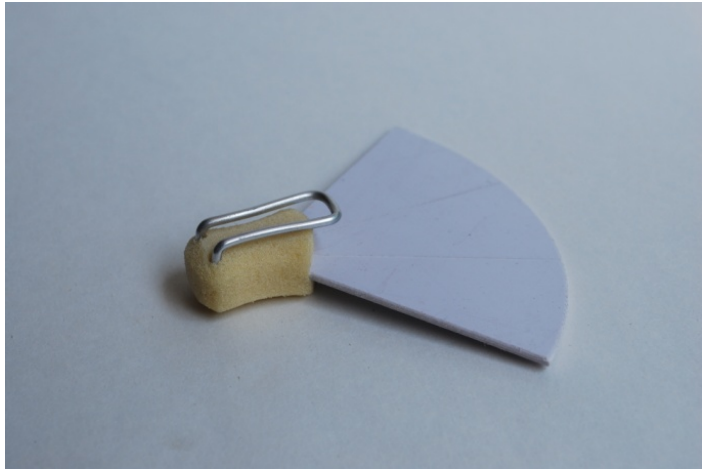

Concept 2



Concept 3

Cluster E

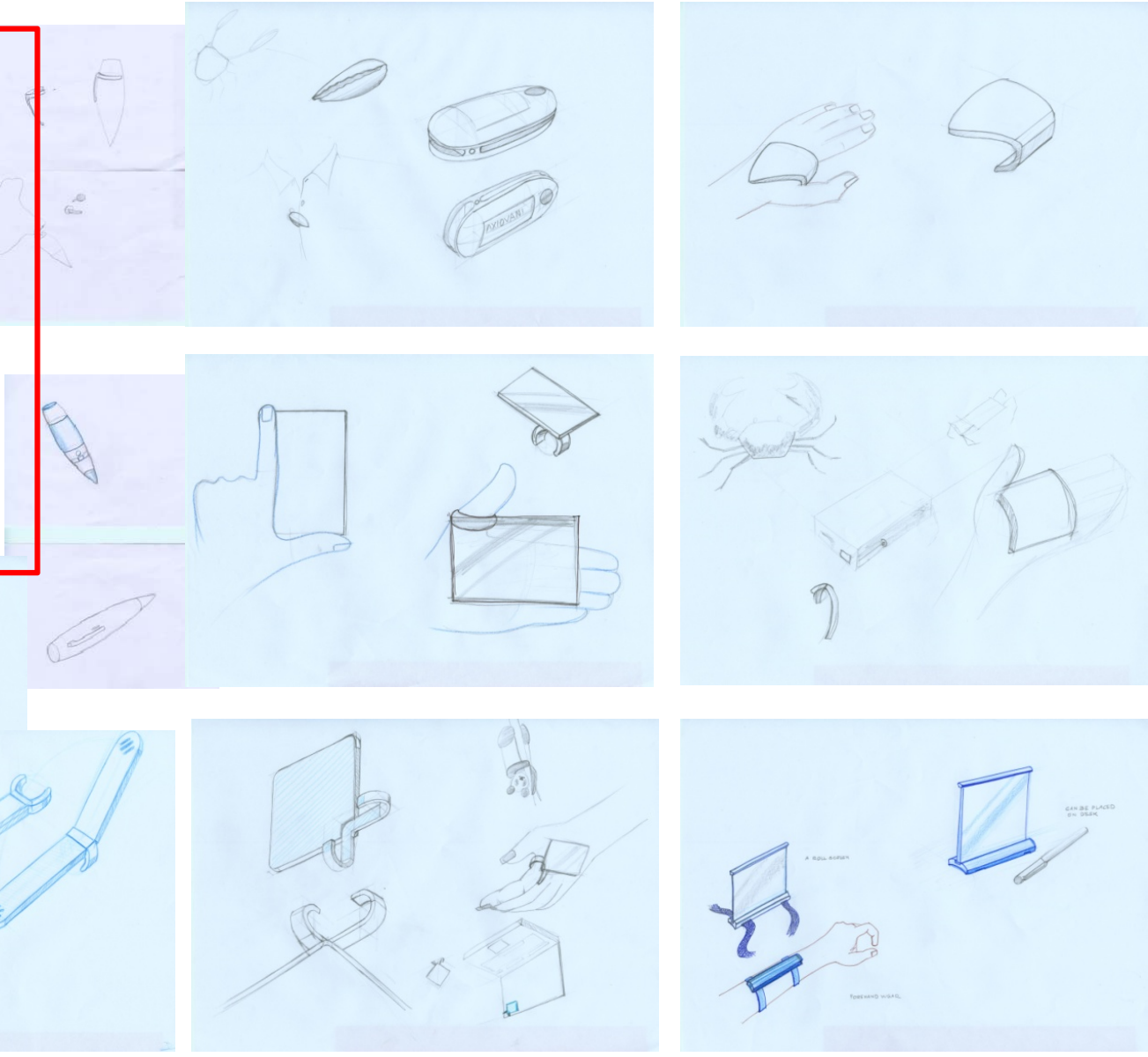
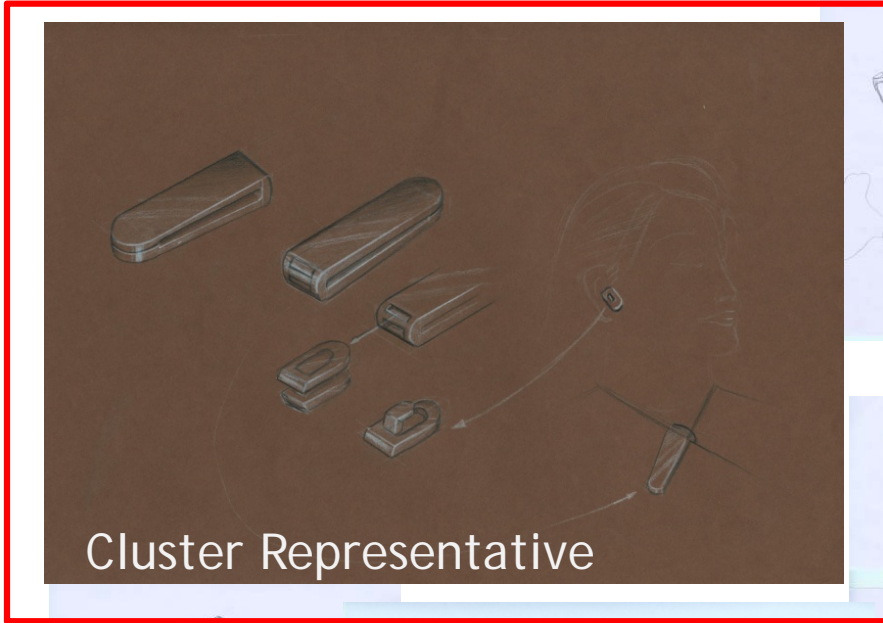

Planar
Simple
Elegant

Concept -E

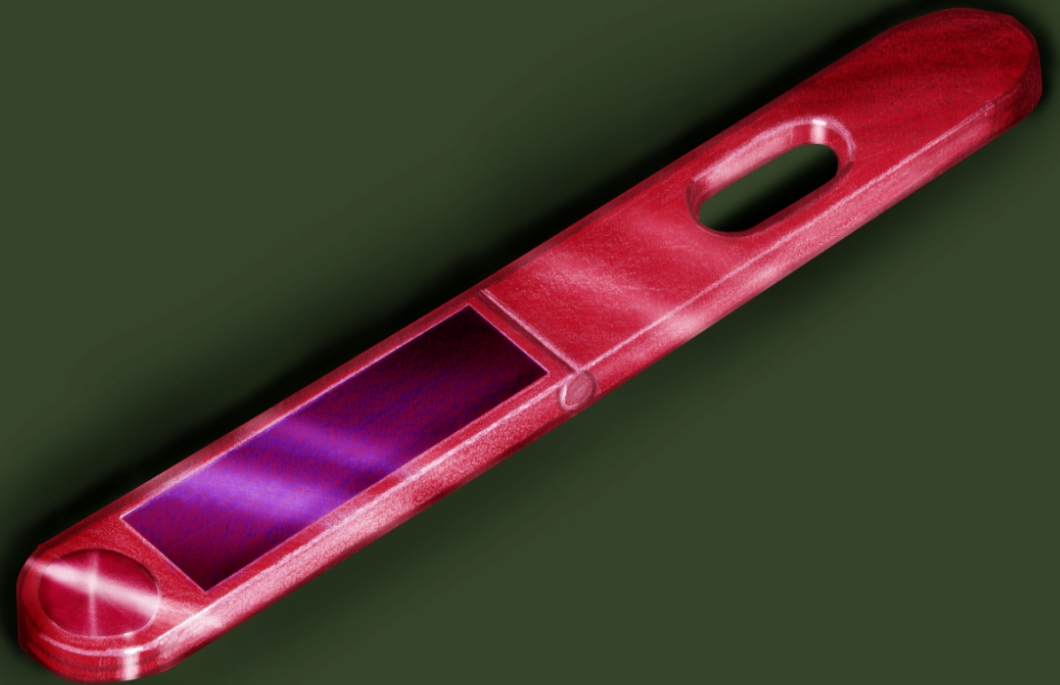
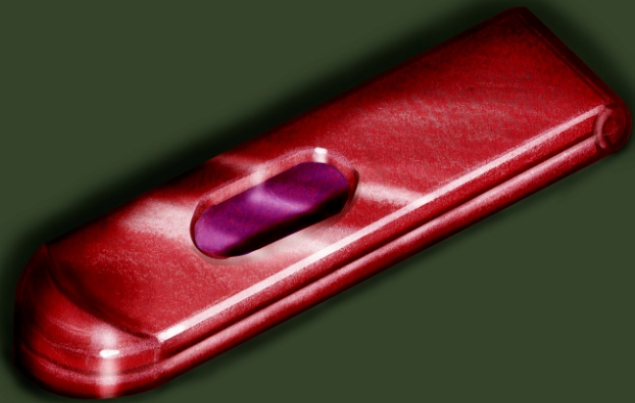

Compact
Techie
Unisexal

Concept -E

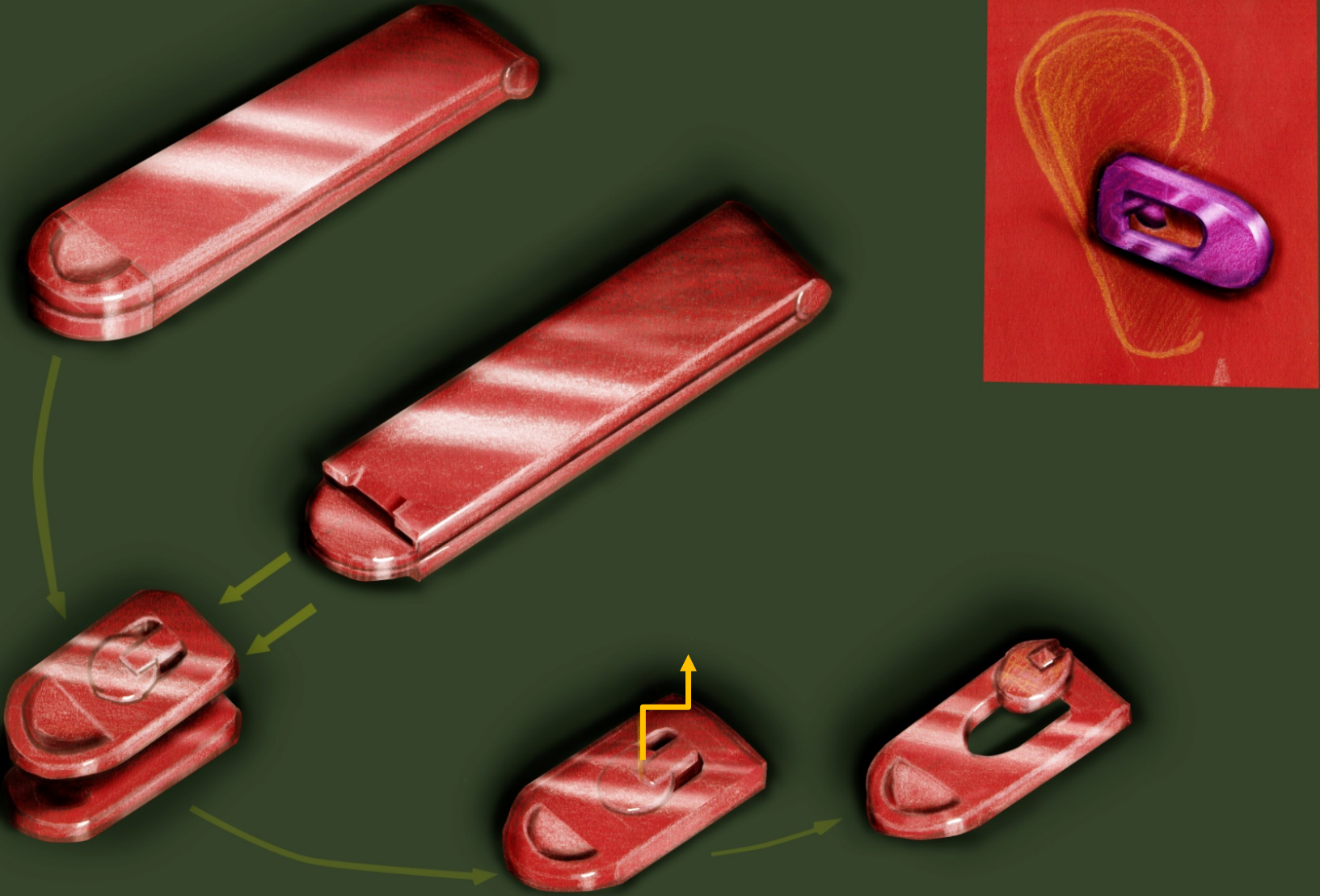

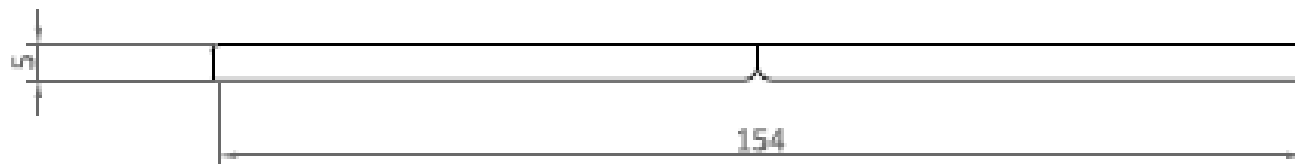
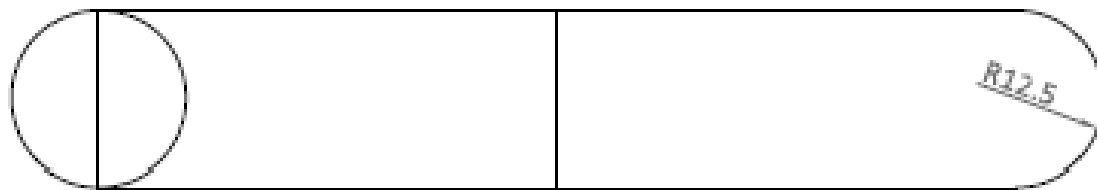
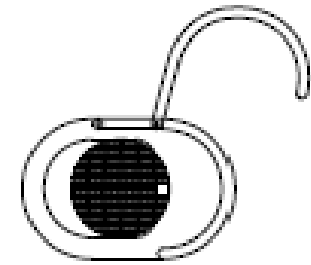
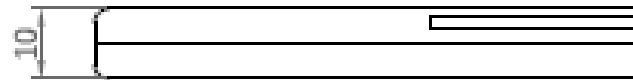
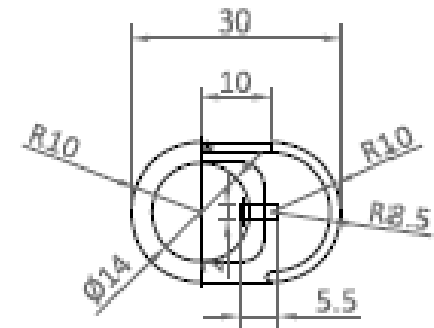
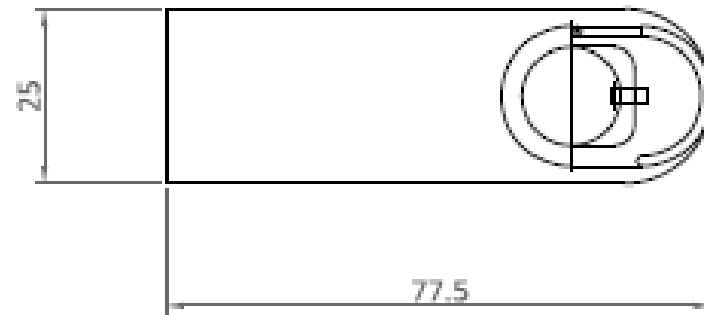

CONCEPT 3

Concept 3

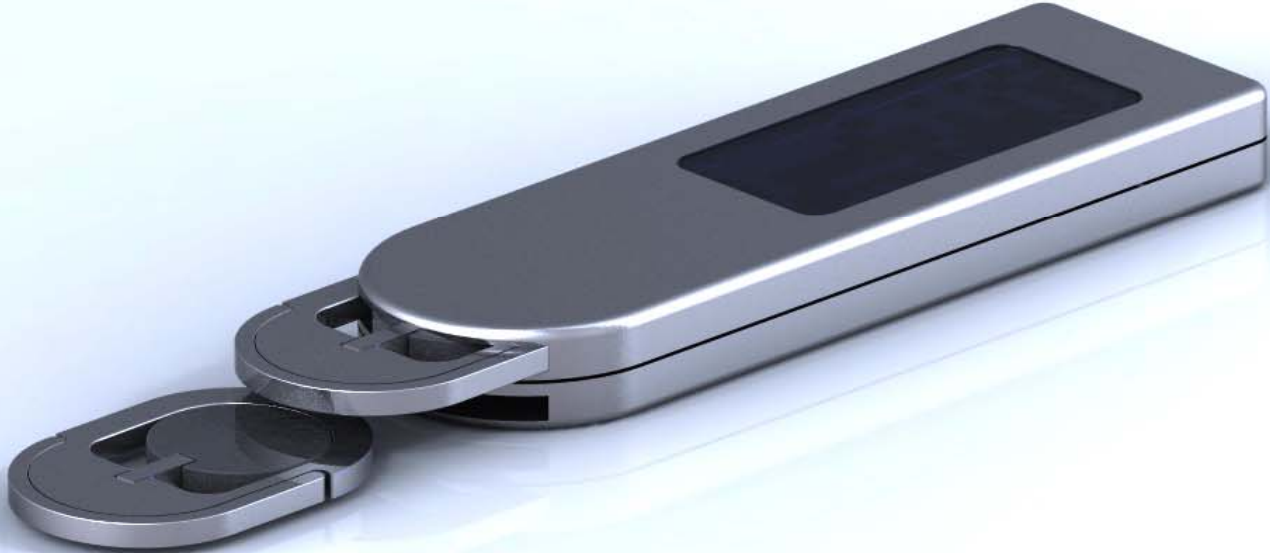

Concept 3



Concept 3



Concept 3



Refinements



Refined Concepts



Concept 1



Concept 2



Concept 3

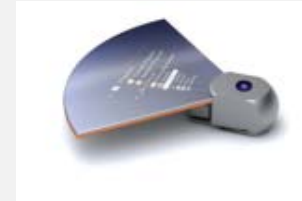

Parameters	credits	Concept		
		1	2	3
Lifestyle statement	15	3	3	5
Personal identity	15	2	4	4
Suitable for office use	10	2	3	4
Effective interaction	8	3	4	4
Convenience	7	2	3	5
Wearability	5	5	3	3
	60	158	203	257

Selected Concept





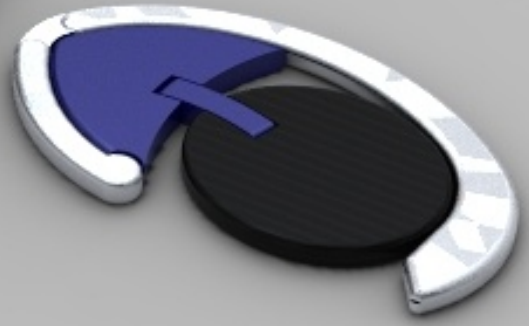
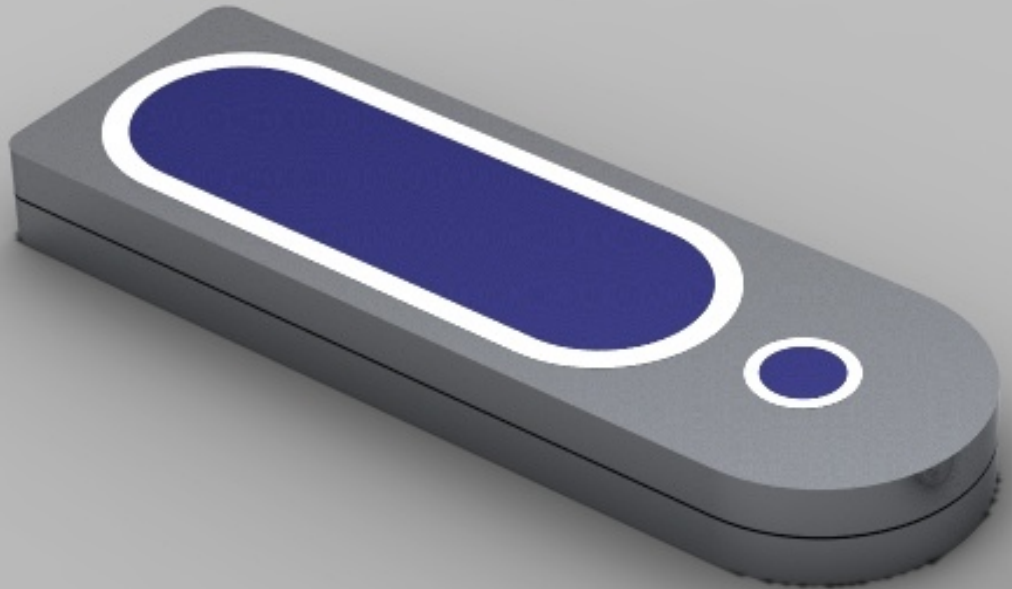

Refinements in Earpiece...

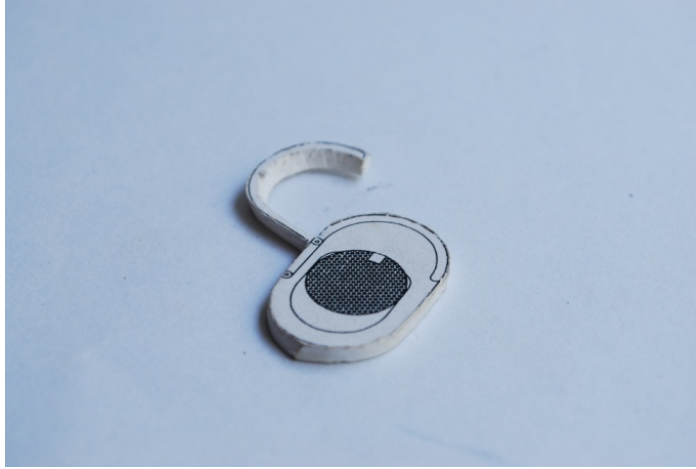
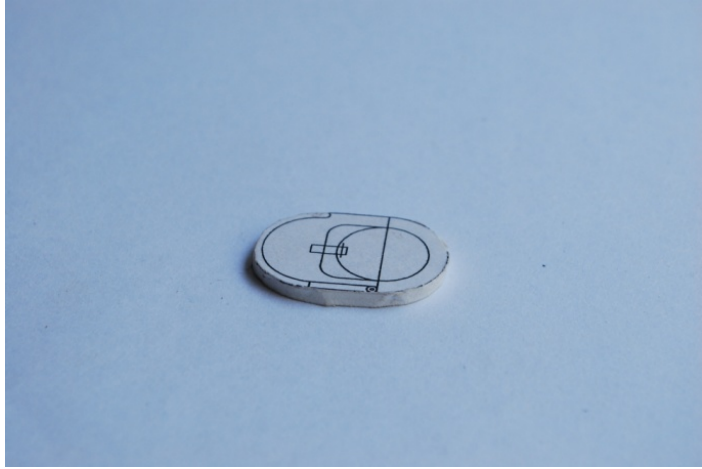

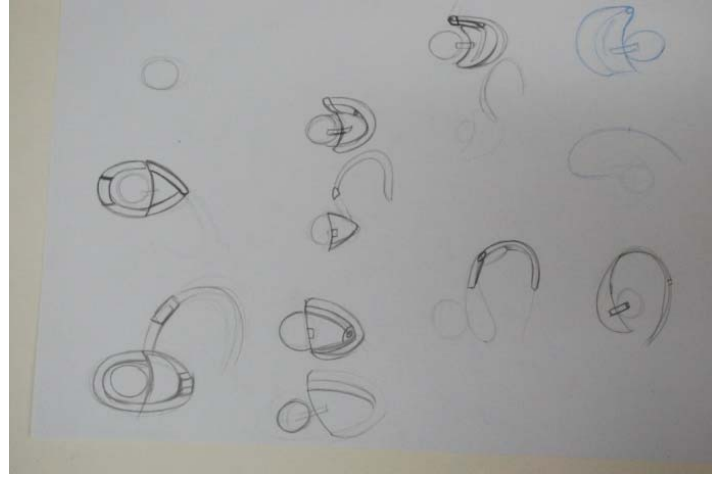
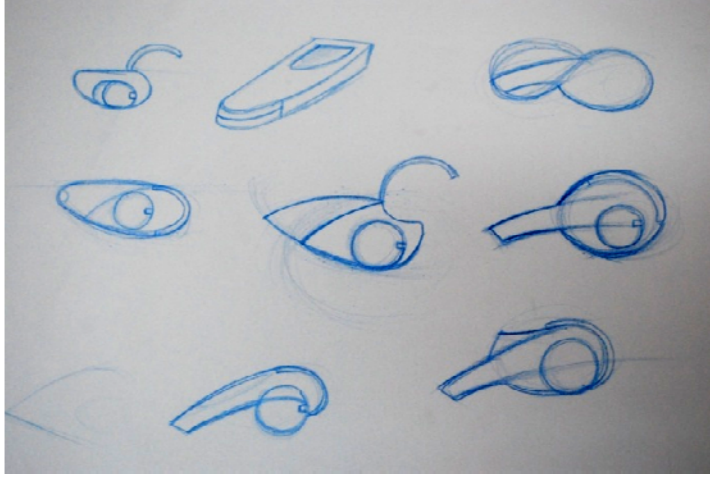
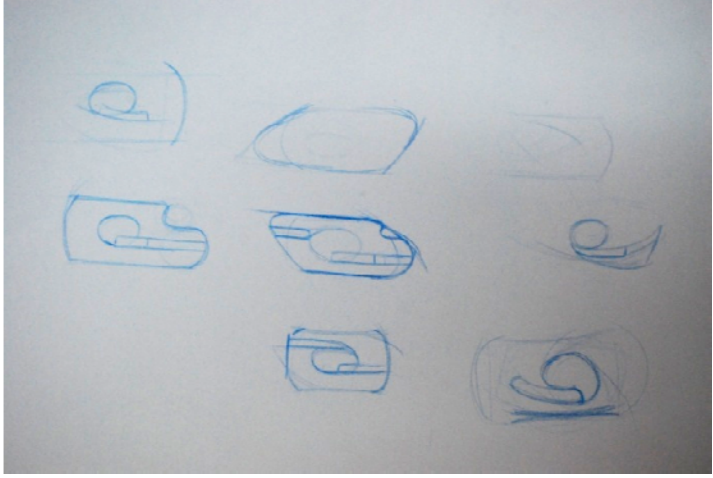
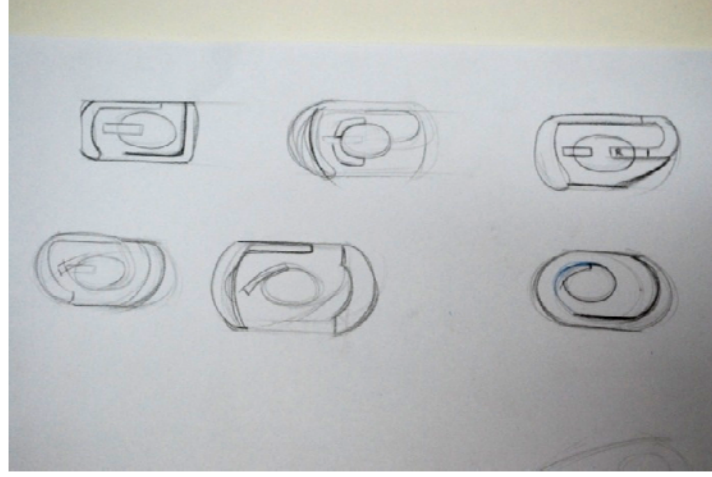
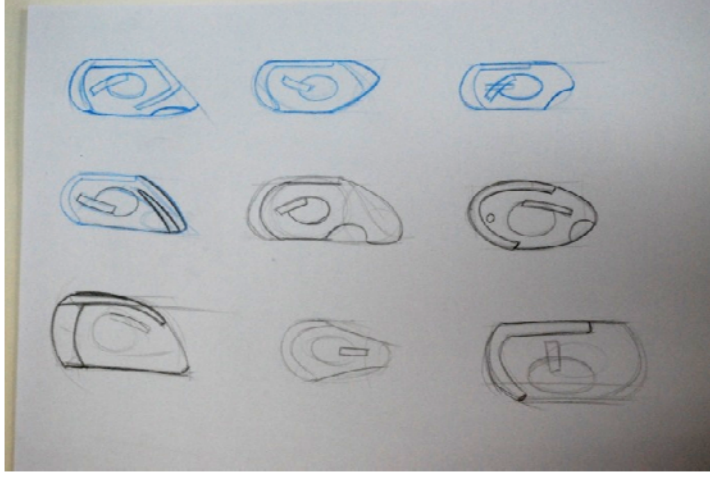
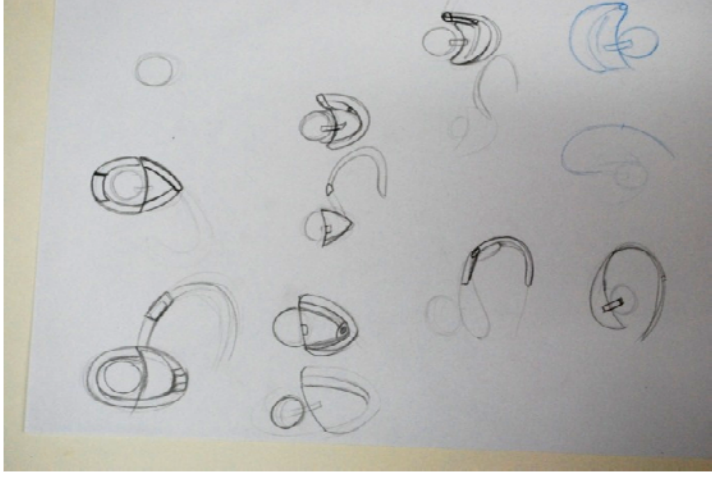

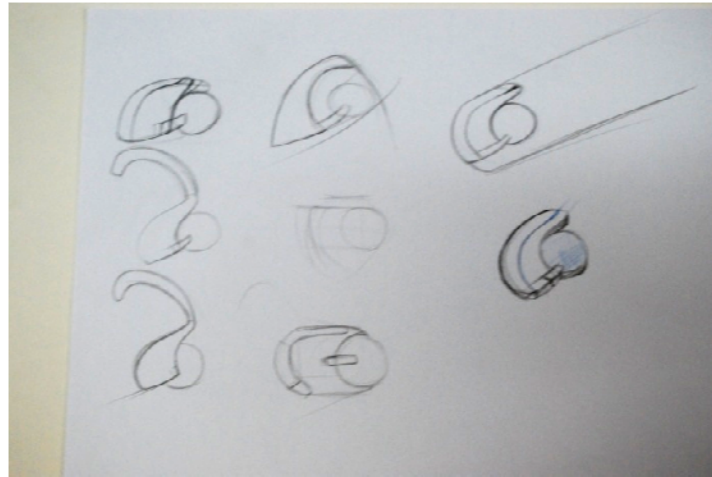
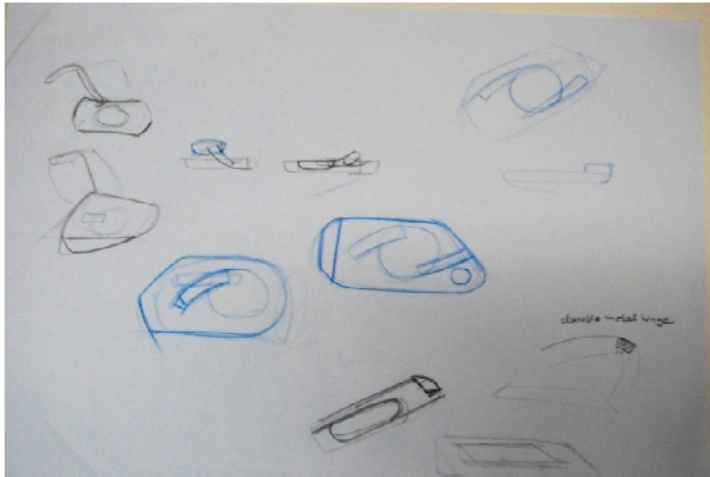
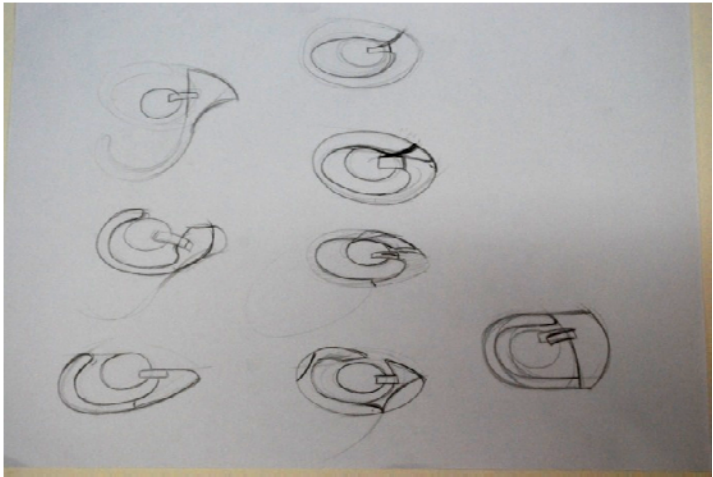
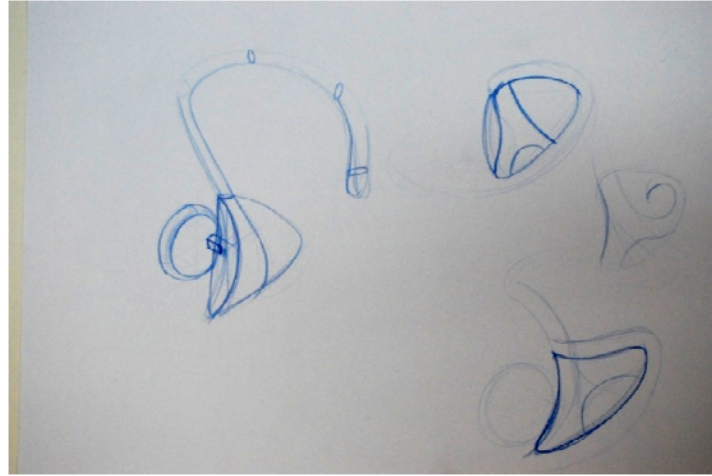
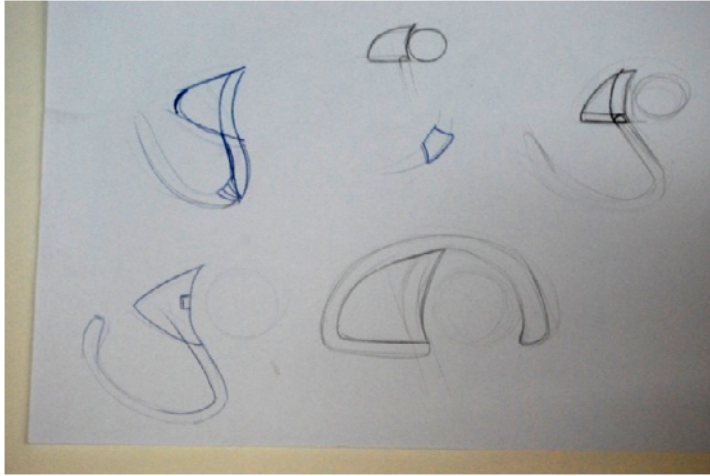
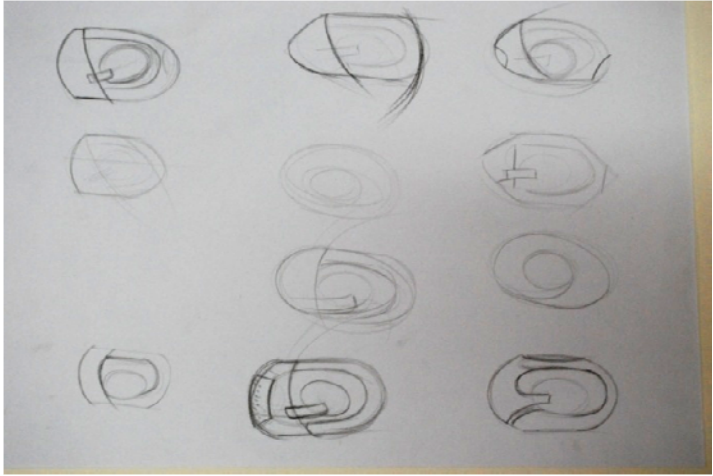



The dimensions of the earphone are decided to 18.5 mm ×16 mm (elliptical).

***Reference:**

Hwa S Jung, Hyungshik Jung, Surveying the Dimensions and characteristics of Korean ears for the ergonomic design of ear related products, International Journal of Industrial Ergonomics, 31 (2003) 361 373

Evolution of earpiece

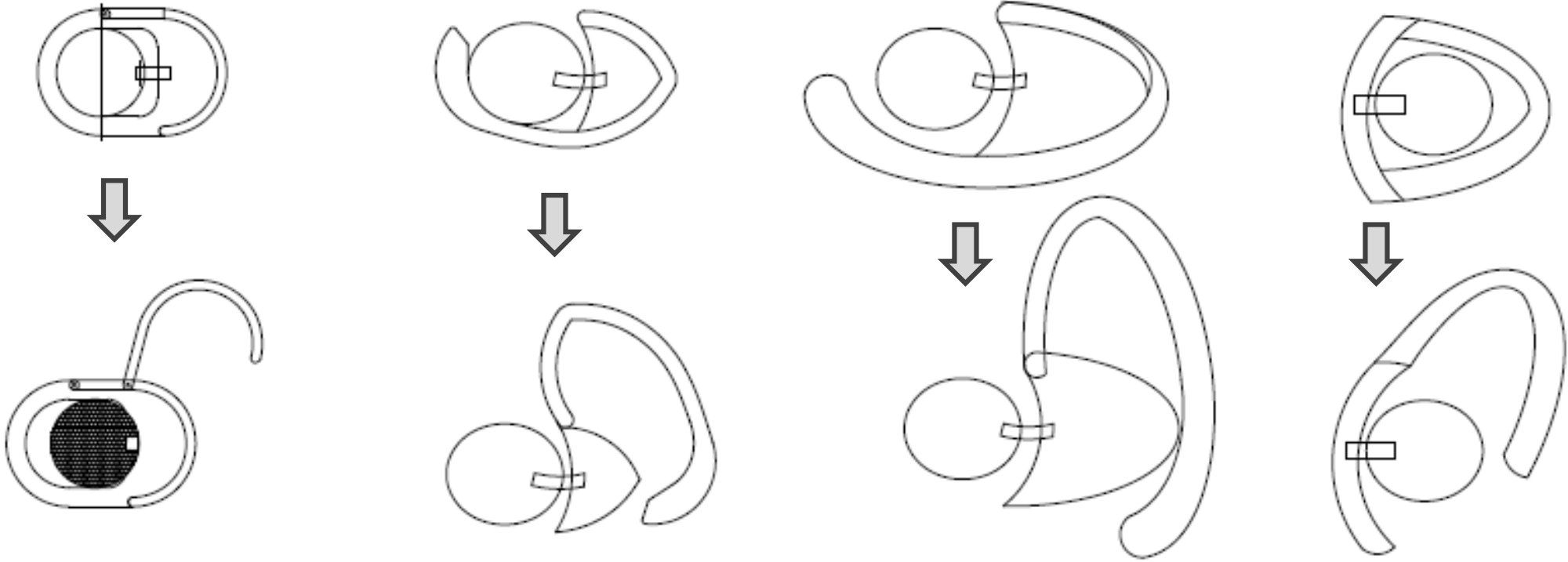



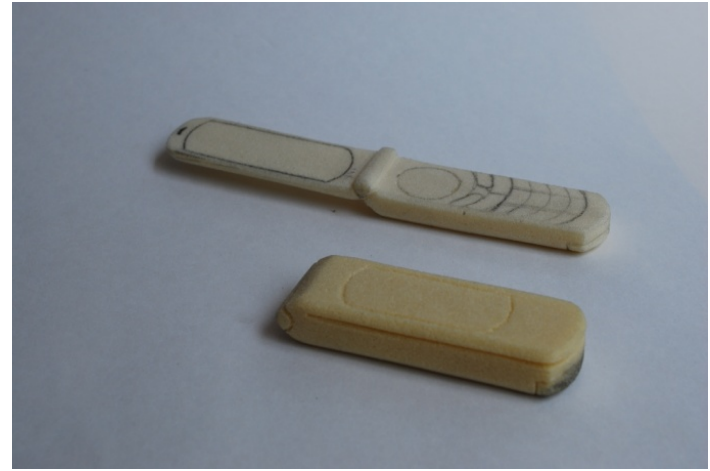

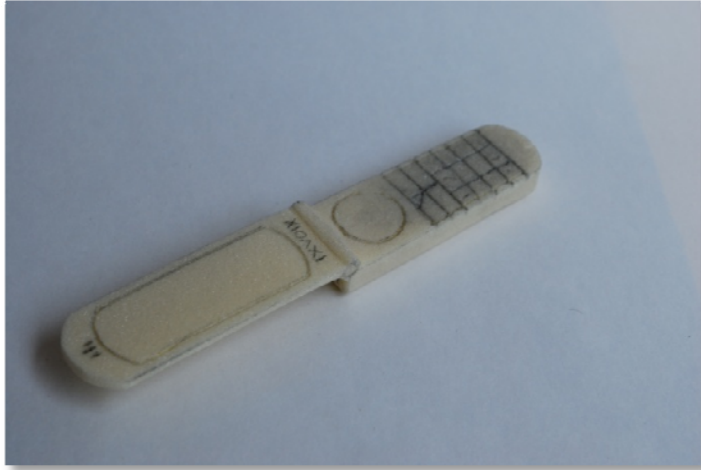

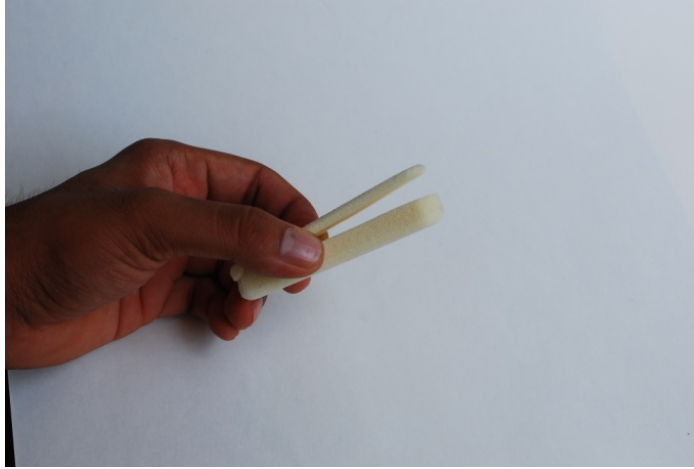

Scenario background...

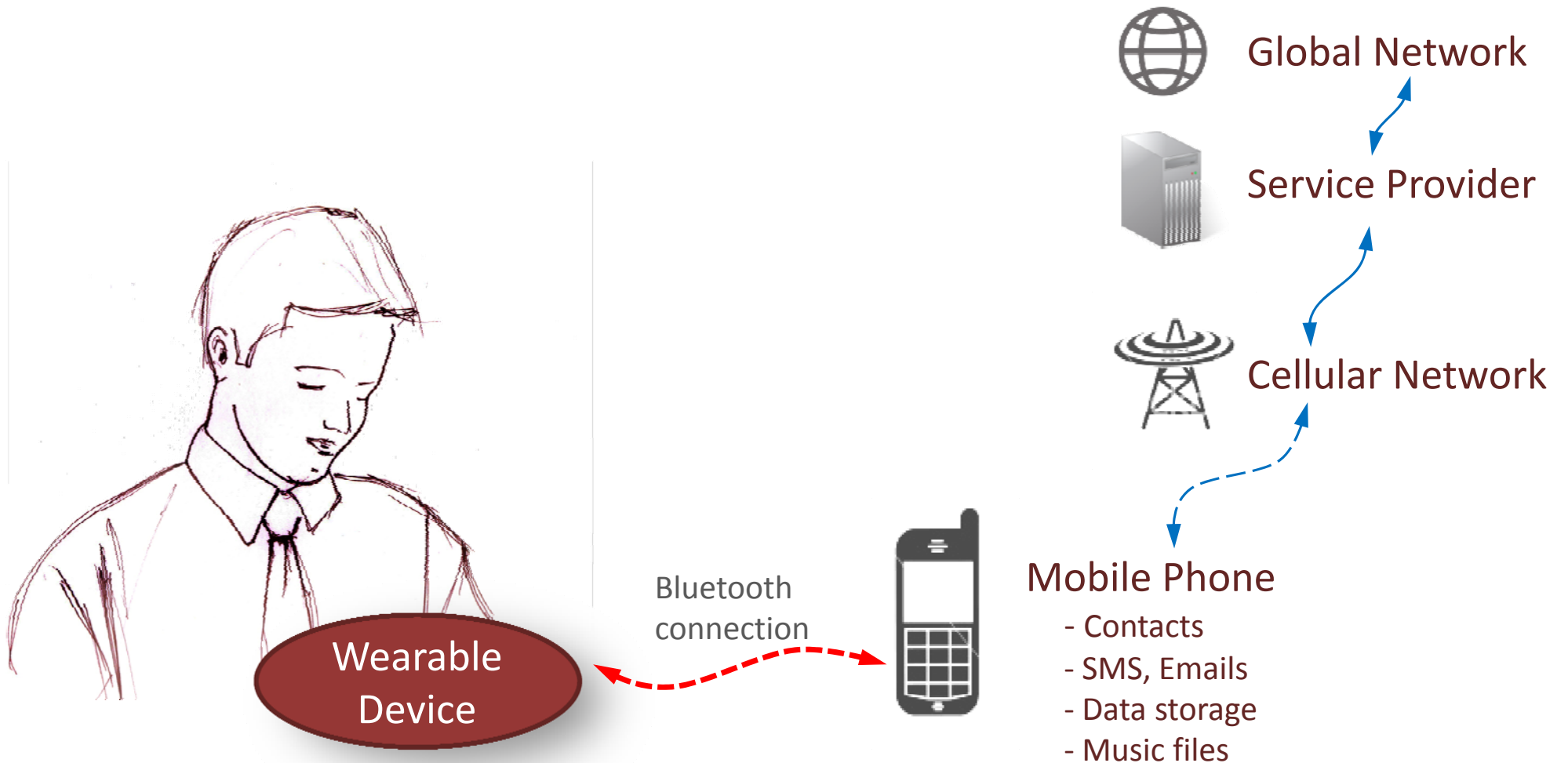

- Closed relationship with user
- Accessing the data from main phone/ server
- Concept of parallel SIM card

Scenario 1 : Communication with Personal Wearable Gadget

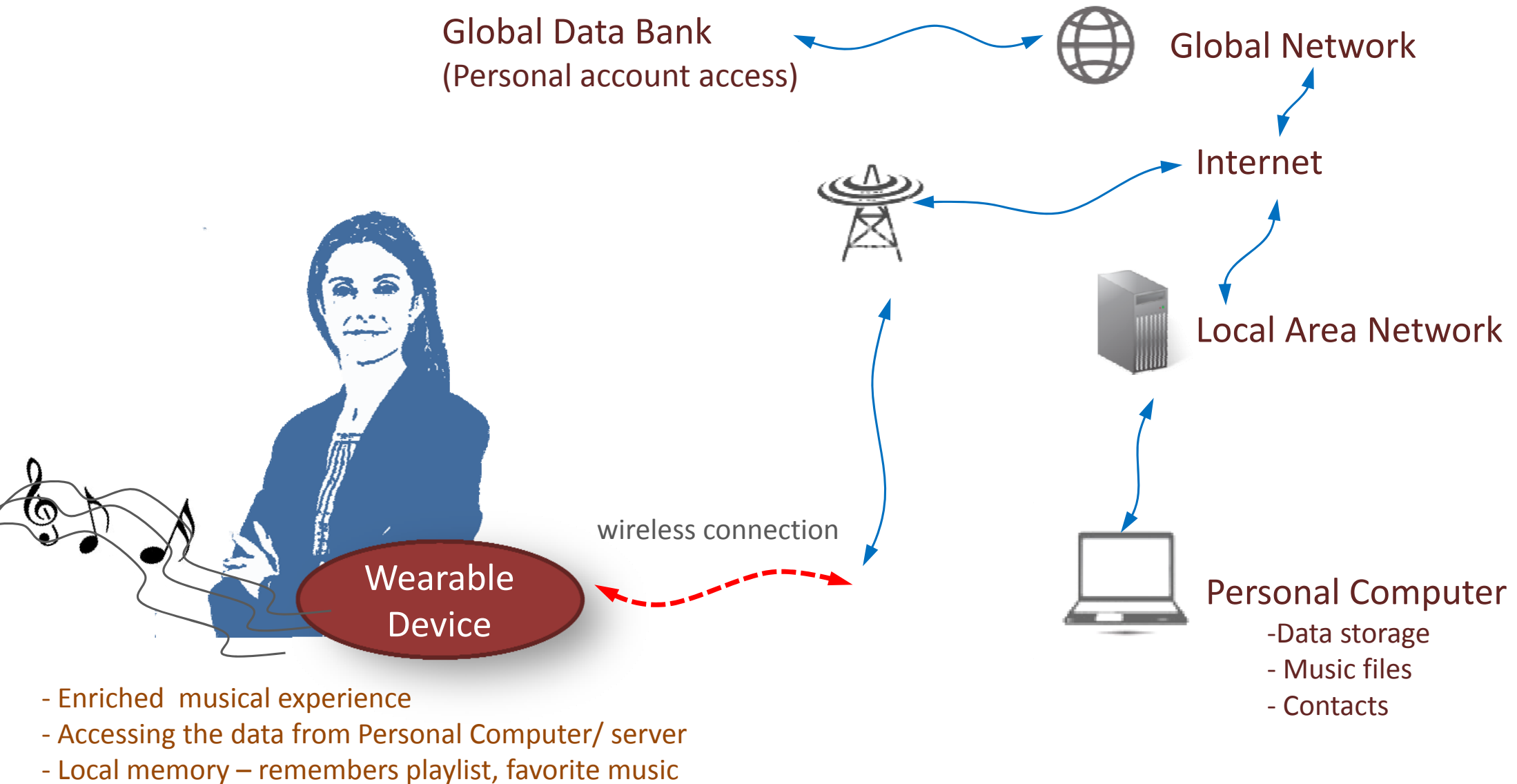

Scenario 2 : Entertainment with Personal Wearable Gadget

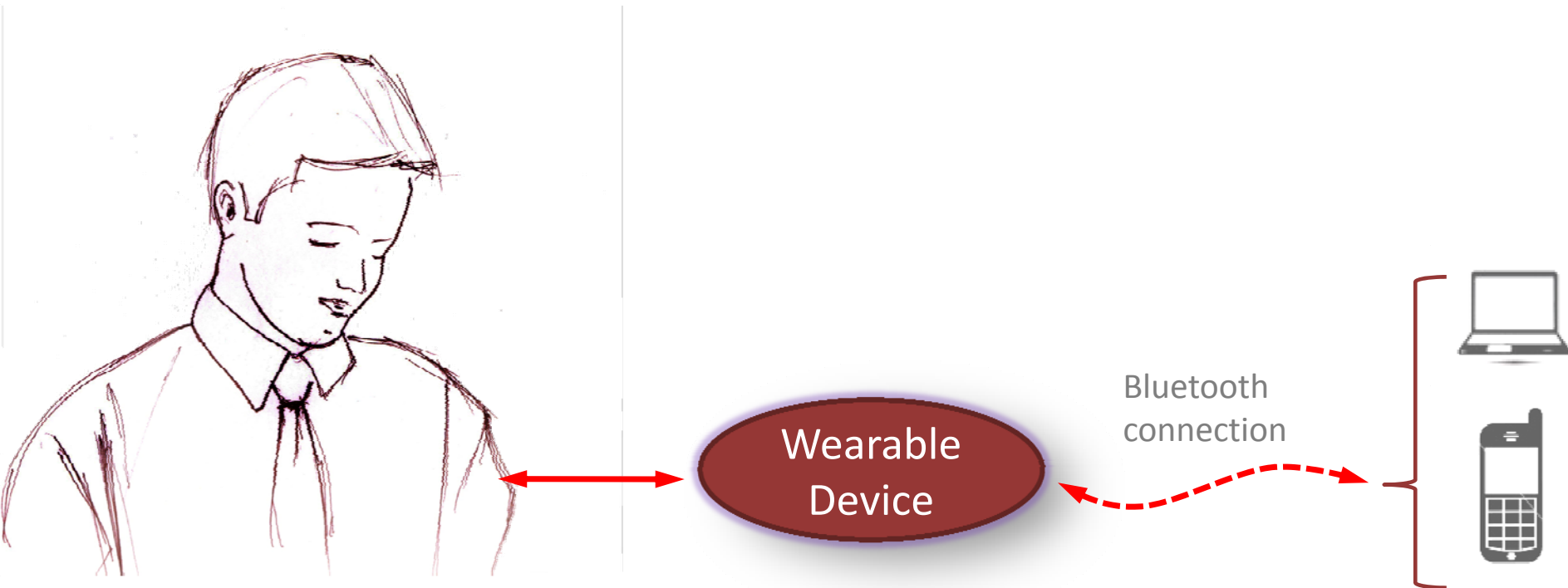

Interface

- Touch screen
- Quick access buttons
- Signal Coding
 - On / Off condition
 - Alerts (Call, Missed call, Message)

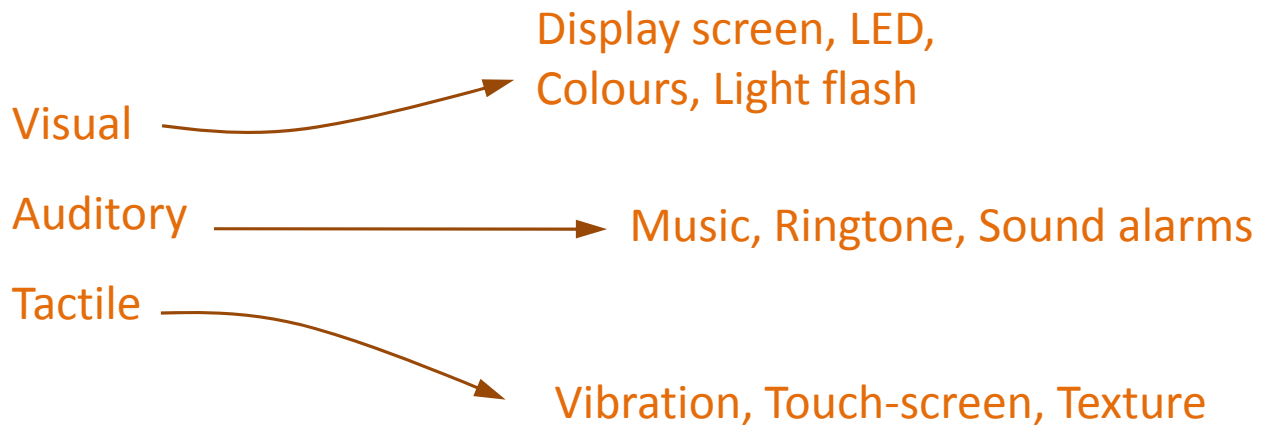

Quick access buttons

For communication



- Navigation & select
- Select/option
- Reject/ Exit
- Call
- Call disconnect

For entertainment

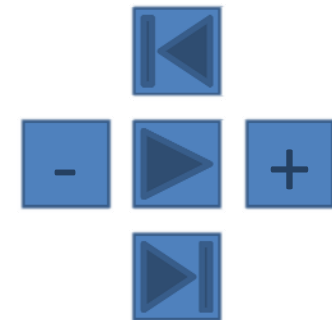

- Play, Pause & Stop
- Volume +
- Volume -
- Previous
- Next

Quick access buttons

For communication



Single Multifunctional button

- Navigation & select
- Select/option
- Reject/ Exit
- Call
- Call disconnect

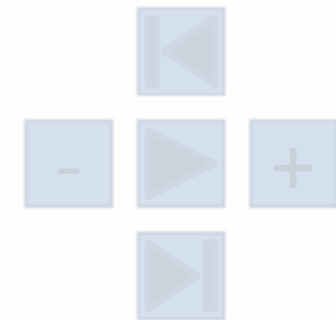

For entertainment





- Play, Pause & Stop
- Volume +
- Volume -
- Previous
- Next

Signal Coding



LED #1

-  On condition Green LED turns on
-  Off condition all LEDs off
-  Low power LED turns red, and flashes

LED #2

-  Incoming call alert orange light flashes
-  Call in process orange light on (constant)

LED #3

-  Missed call blue LED turns on
-  Message alert blue LED turns on
-  Reminder alert Yellow LED flashes

Persona...



Miss Sharma

age 29 years old
corporate personality

She is executive manager in a
multi national company

Rationalist, Freethinker, Social,
Fun-loving, Techie, Stylish,
Music lover and believes in self
identity

Scenario 1



She reaches office



Arranges her laptop on desk

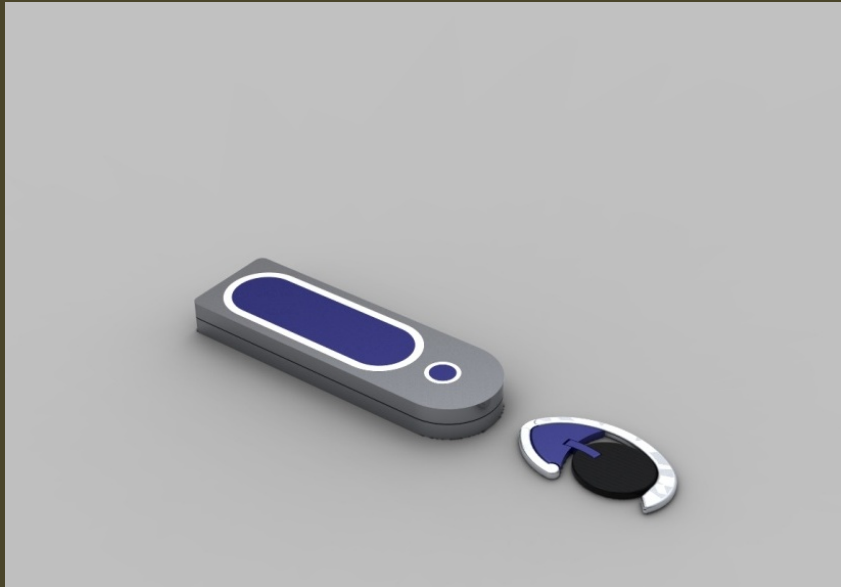

She has a 'Wearable device'
She takes out the earpiece from the main gadget.



She wears earpiece on ear
& clips the main gadget on her dress.

...and starts her work



She is busy in her work now.



Her wearable gadget alerts her that she has an incoming call.



She checks the screen for caller's name.



She receives the call and enjoys the conversation



As she is a music lover, she feels better while listening to her favorite music.

Whenever she needs to get refreshed she listens to music



She need to relax

So she turns on music, and enjoys with help of the “Wearable earpiece”

She has to attend an important meeting with board of directors.



As she don't want to receive call or listen music during meeting, she removes the earpiece and places it in the main gadget.



During meeting she have an incoming call.

She checks the screen for callers name.

It is some unknown number. So she ignores it.



The meeting get over after an hour.
Now she is back to her desk.

She takes out her 'wearable gadget'. Gadget signals her that there is a missed call.

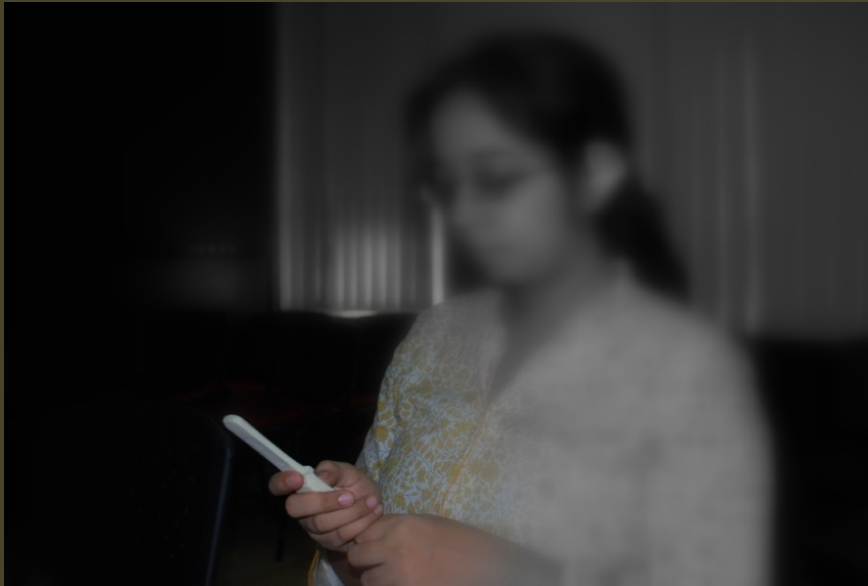

She opens the flap.
And calls back to the concern number.



Now she is talking to the person on phone.

Scenario 2



She is fond of modern jewellery and also like techie things.

She recently got an wearable gadget for music listening. This gadget is a fusion of jewellery and style.



She wears the gadget always. Which looks like an trendy jewellery piece

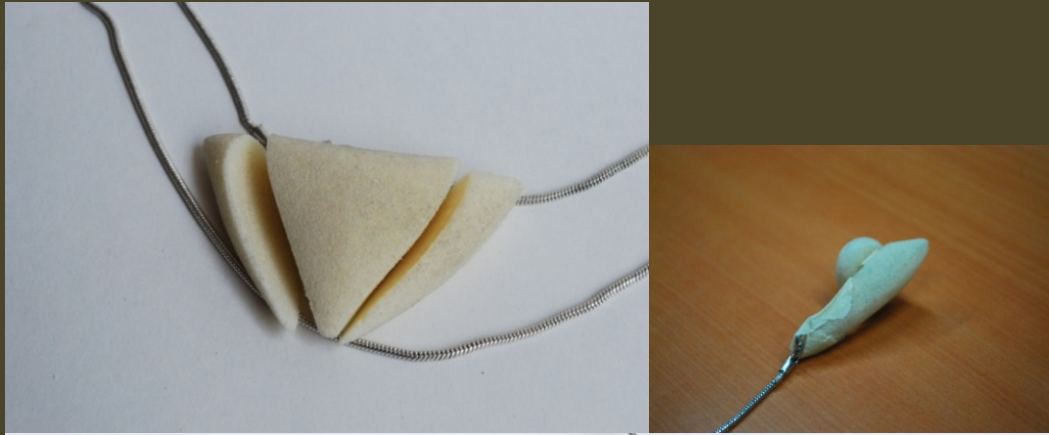

Whenever she feel to listen music she
removes the earpieces from the pendent and
wears in ears.
And enjoys the music

Developing a **product range**...



The product range is developed by relooking at the ideations ...

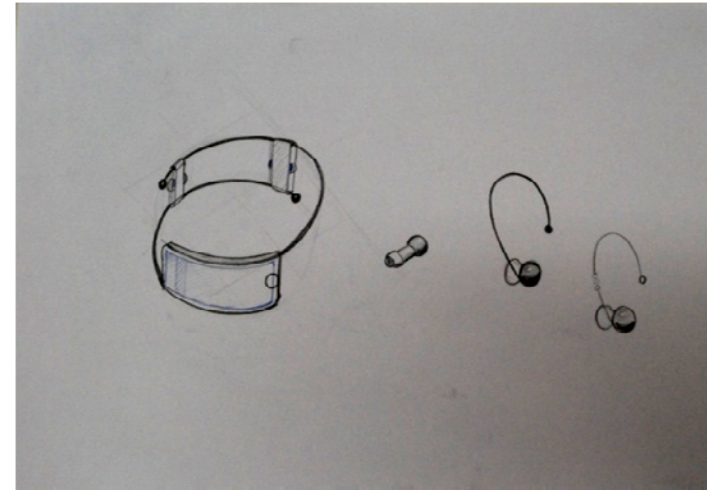
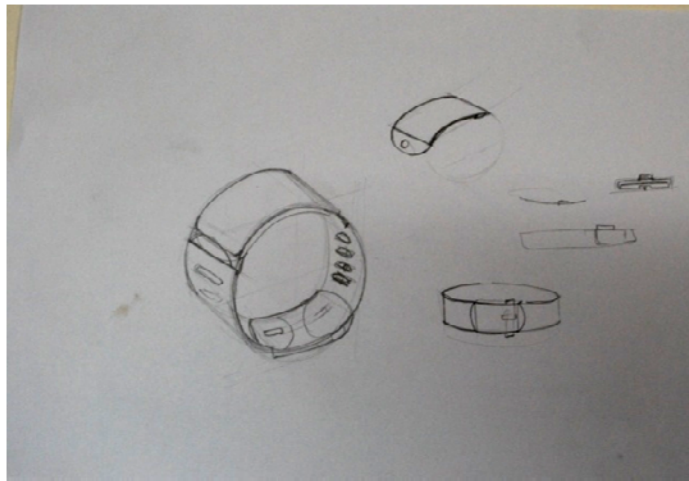
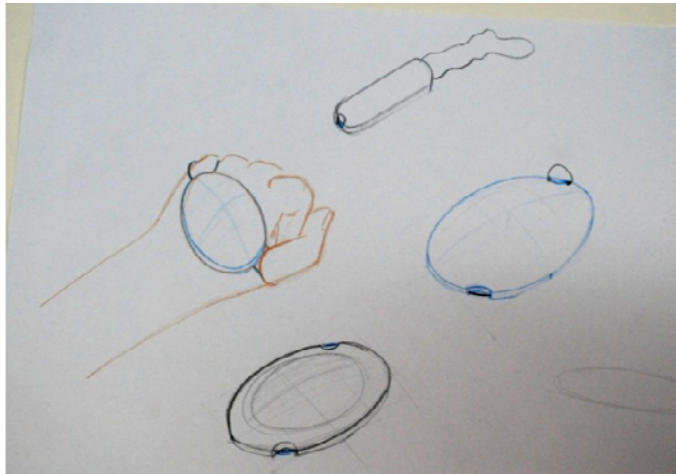
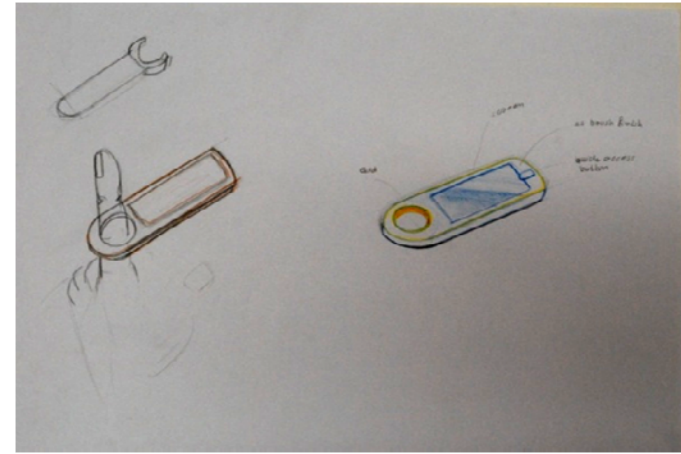
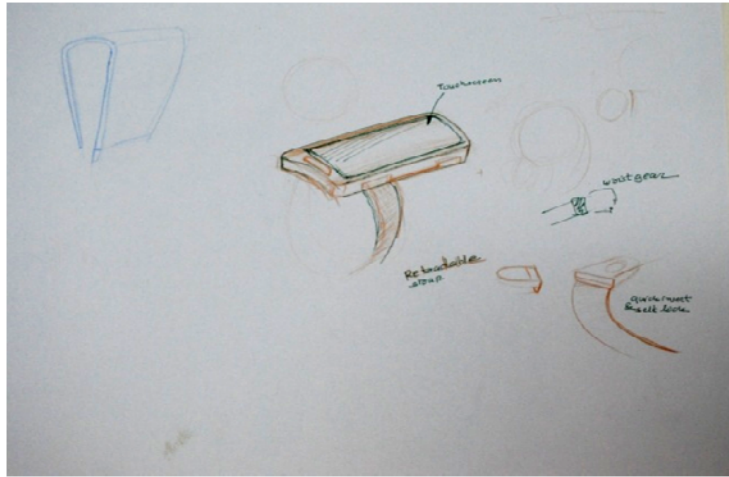
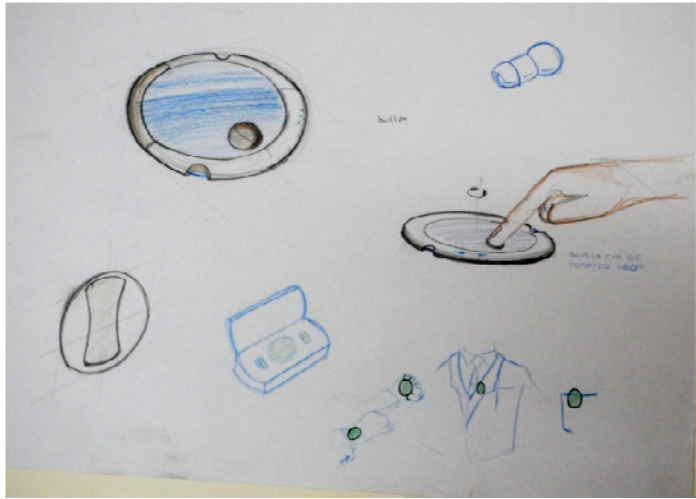



D'fixing the future

4D Earpiece

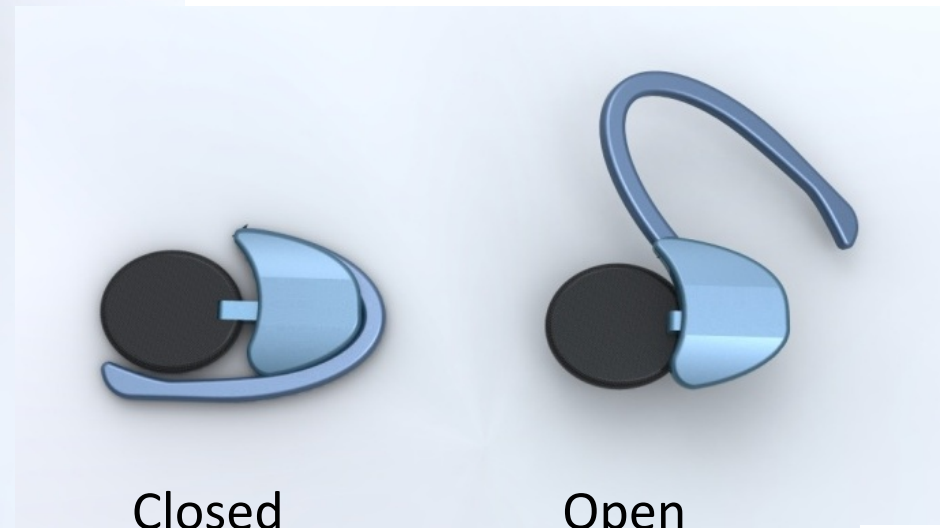

Closed
Condition

Open
Condition







D'fixing the future

4D 1



Difining the future

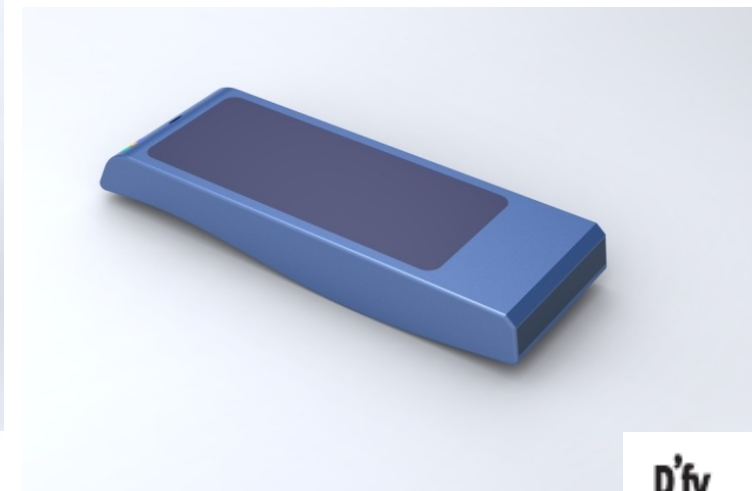
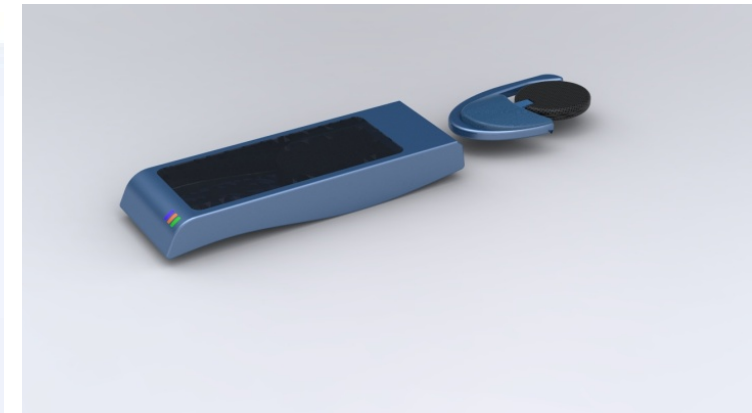

D'fy_{4D}

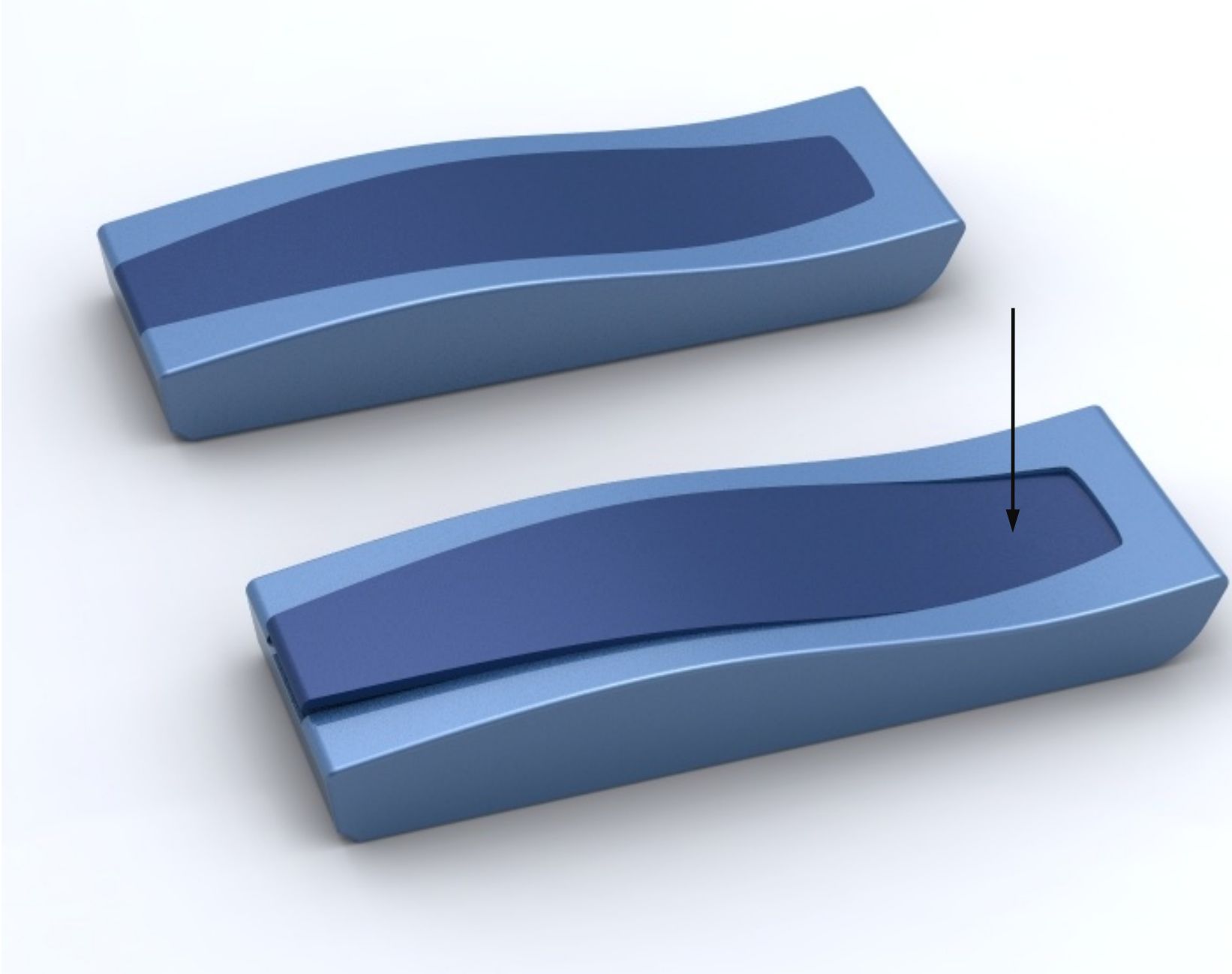

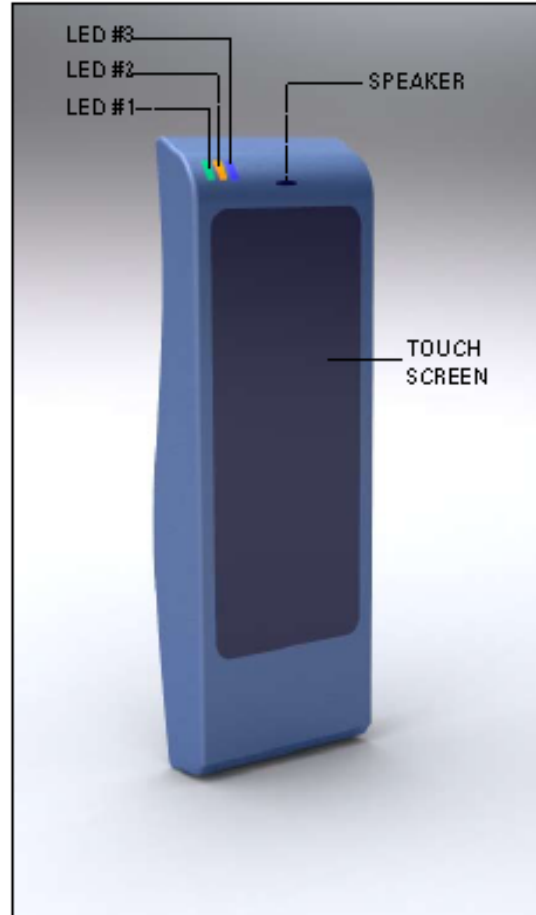
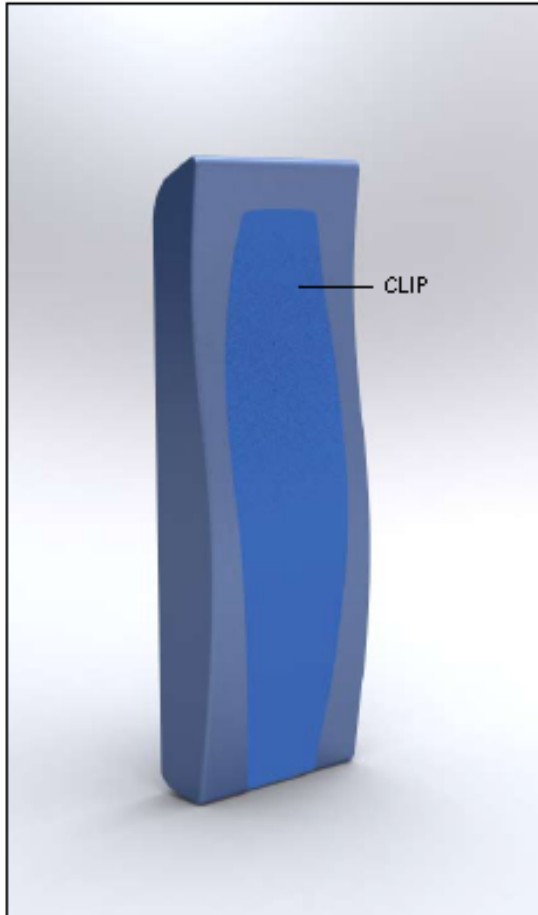

LED #1
On condition
Off condition
Low power

Green LED turns on
all LEDs off
LED turns red, and flashes

LED #2
Incoming call alert
Call in process

orange light flashes
orange light constant on

LED #3
Missed call
Message alert
Reminder alert

blue LED turns on
blue LED turns on
Yellow LED flashes



D'fixing the future

4D 2



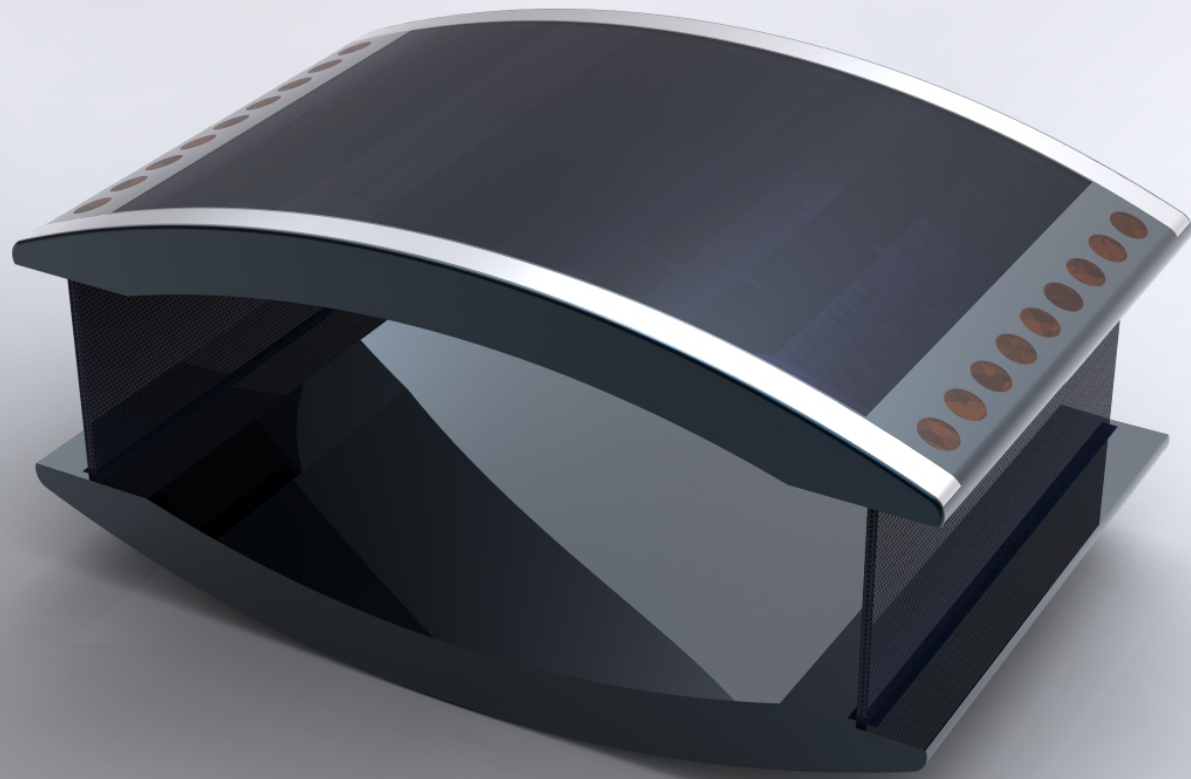

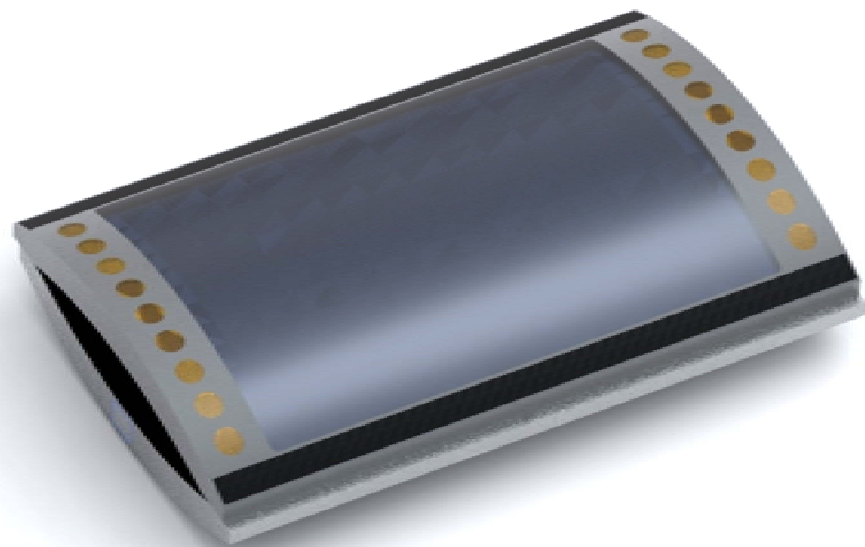
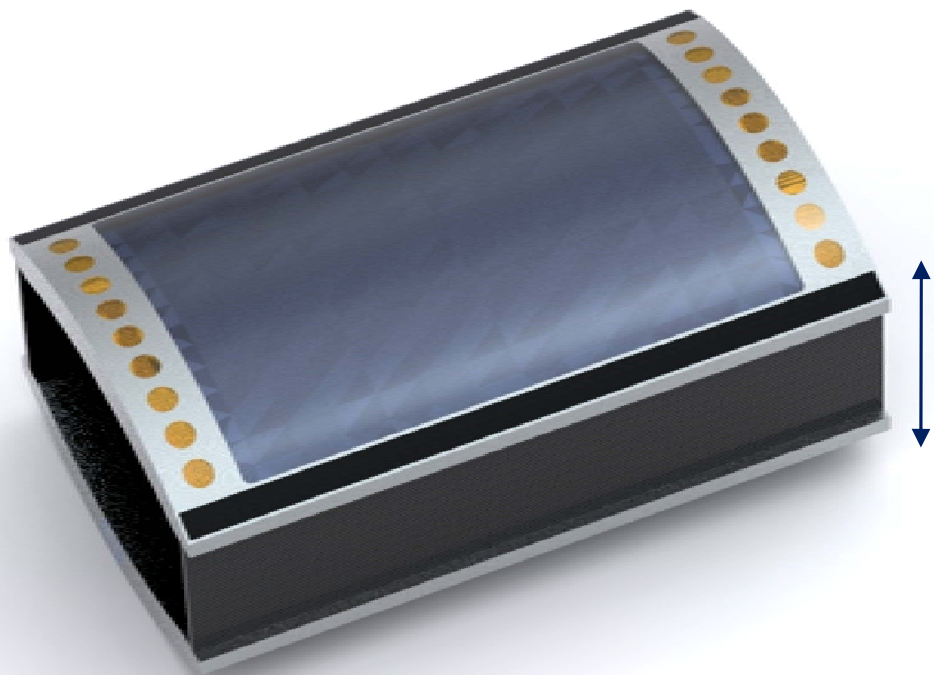

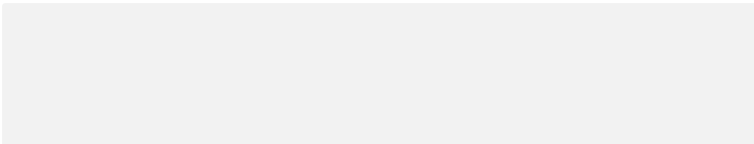
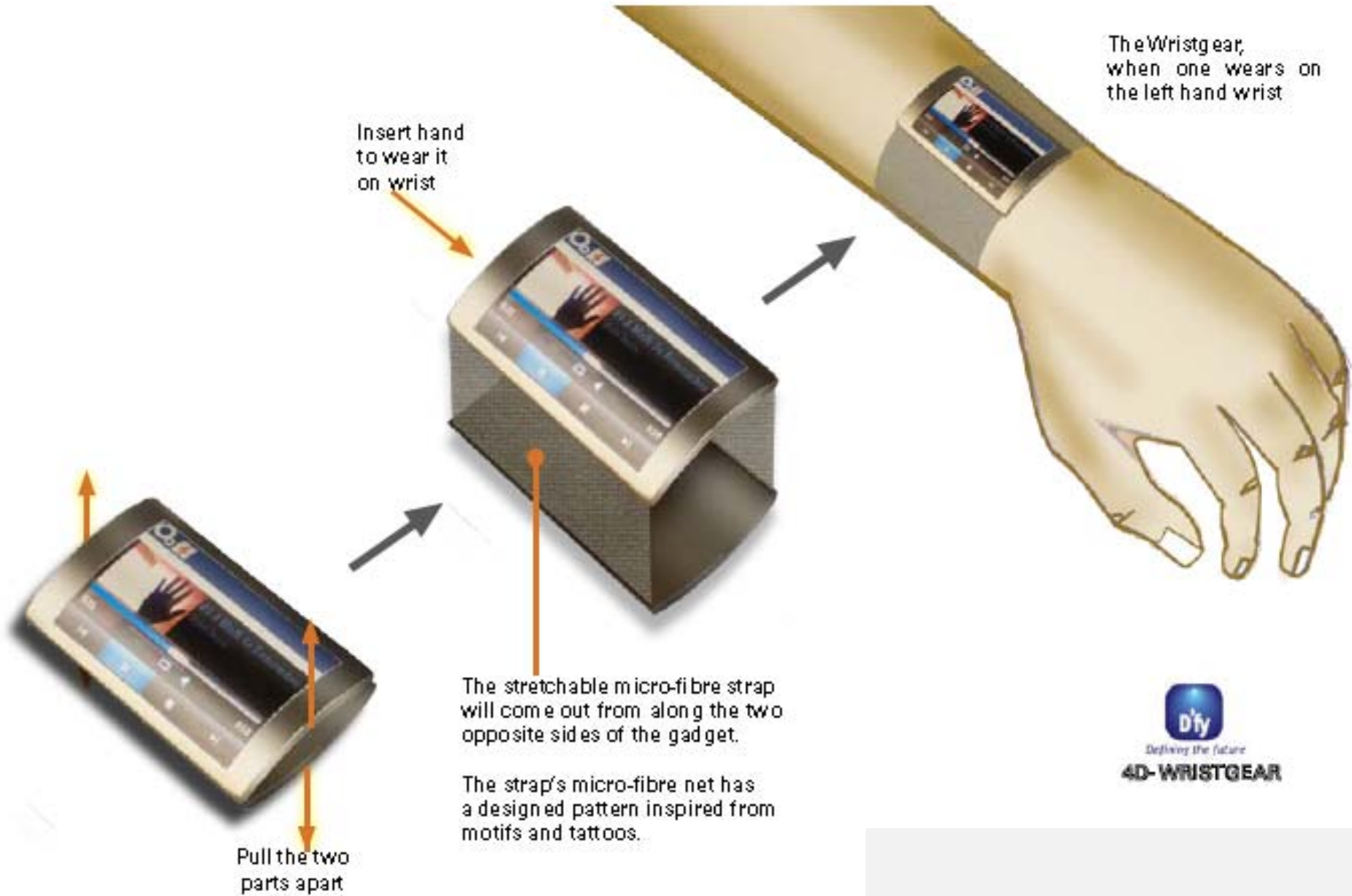

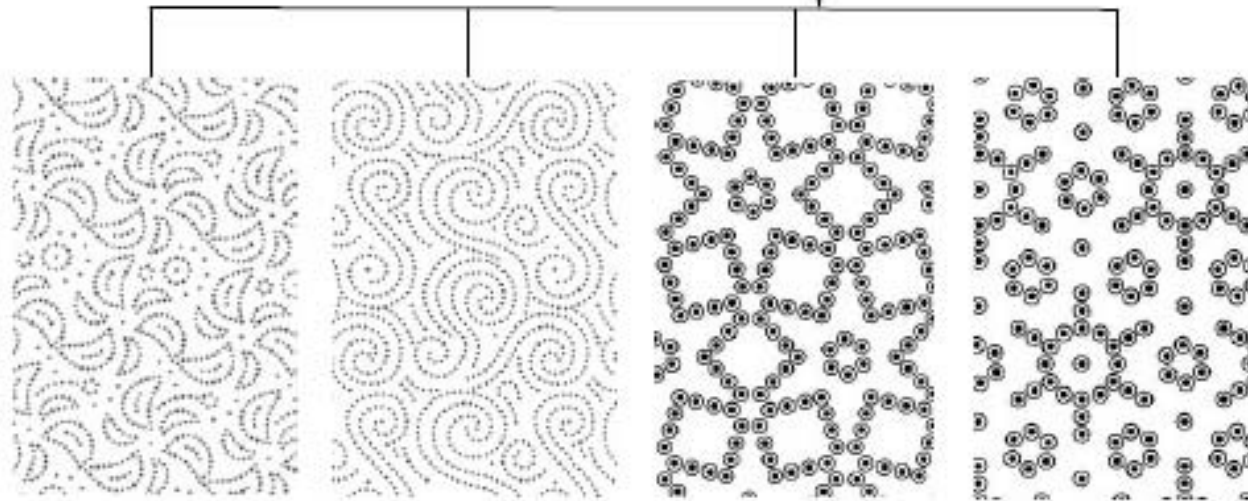



D'fixing the future

4D 3

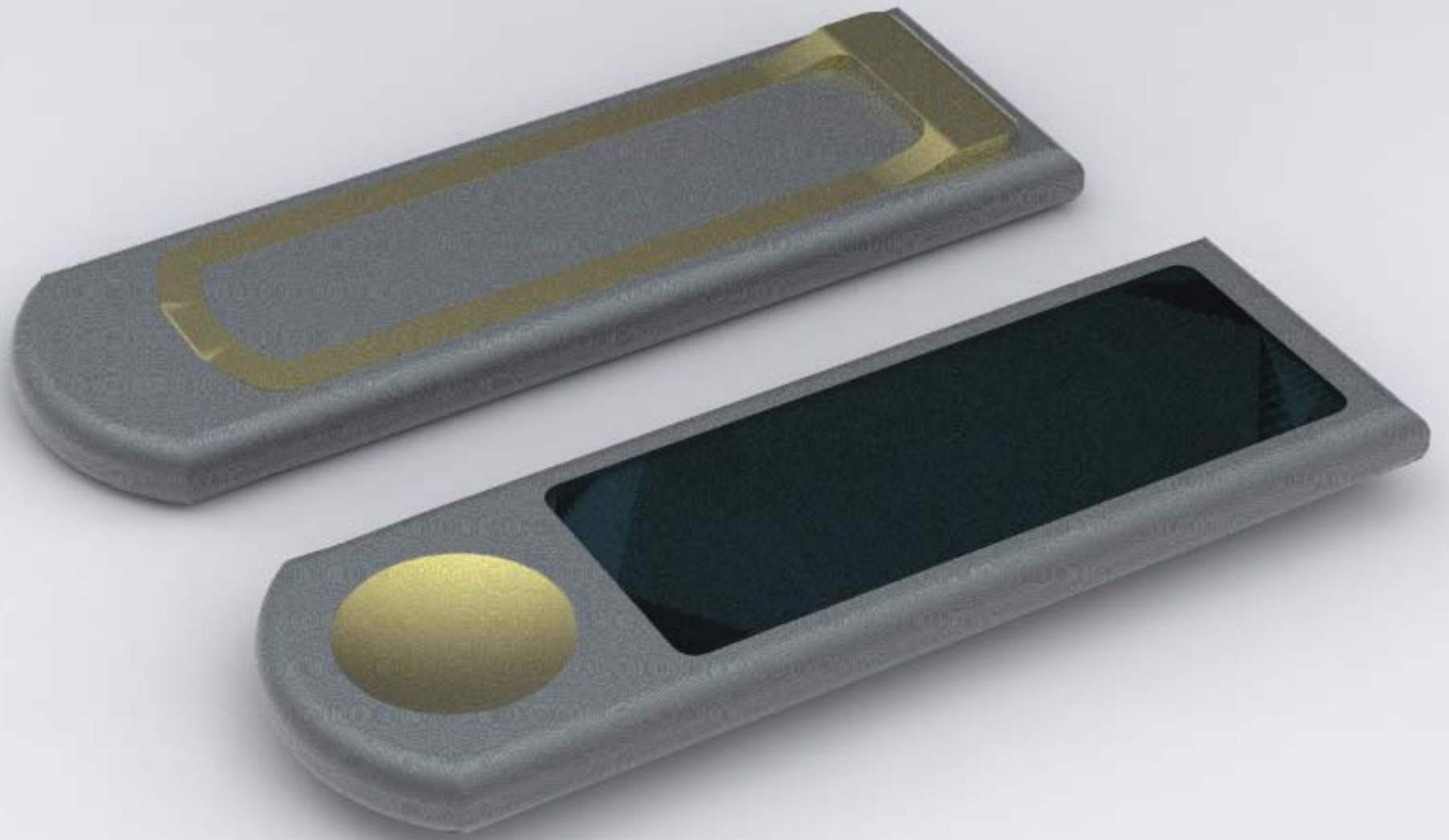

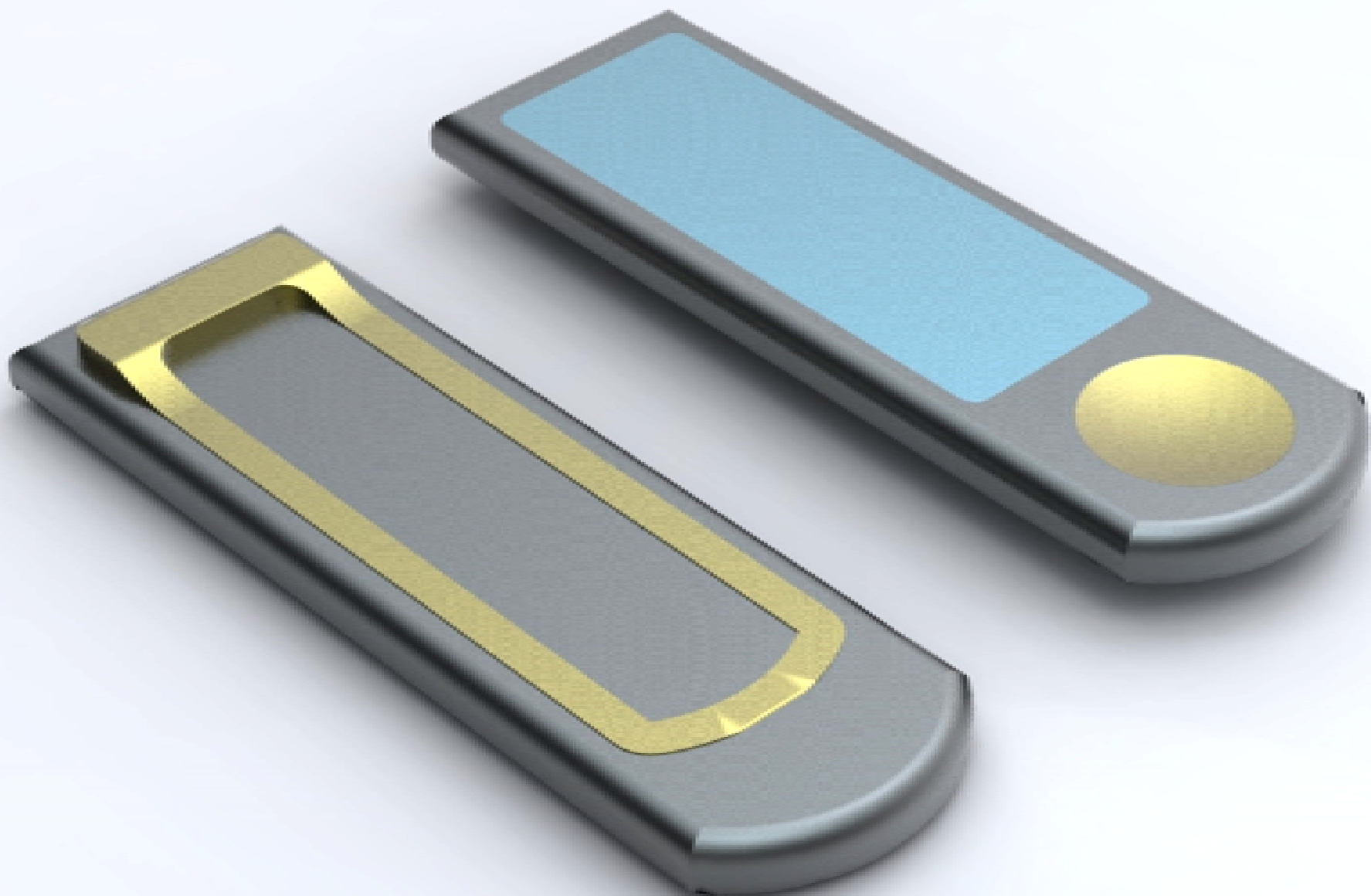

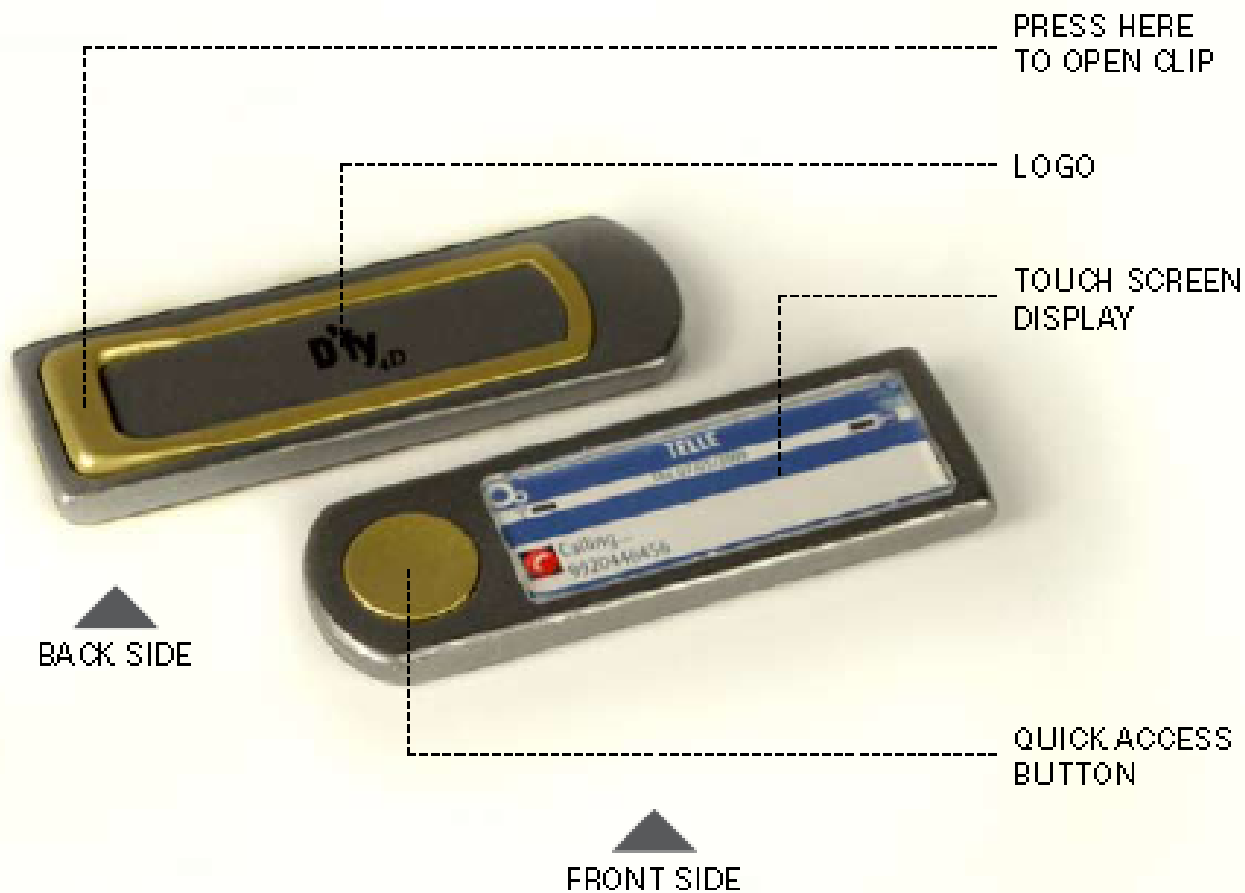

Features:

- This is a communication and entertainment device
- It communicate with its accessory, 4D-Eargear with help of Bluetooth.
- It has a multifunctional single quick touch button, with which one can easily operate the device quickly.
- It has a touch-screen display.
- It is a compact device.
- It has a clip on the back side. One need to press the clip to open it. With the help of this clip, it can be easily clipped on Blazer, Pocket and Cuff.

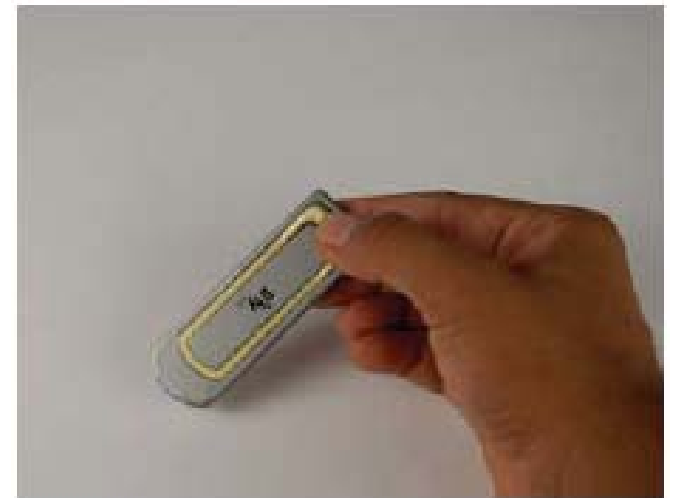

Thank you ...