

# *DESIGN OF AN ELECTRIC CART FOR MALLS*

GUIDE: PROF. K . MUNSHI

SHWETA SUTHAR

05613003

IDC - IIT-BOMBAY - 09 MAY,'07





## **Project brief**

Design of an electrical cart for malls.

Ideal transportation solution for short distances for both mall visitors as well as the working staff within the malls

## **Methodology**

Overall existing product studies

Contextual studies

Technical studies

Inferences

Formulating product brief

Ideation

Concept generation

Explorations

Final product

Mock up models

Full scale study model

Scaled model

## Scopes and limitations

**Addressing User categories** - The vehicle will address the issue related to transporting different categories of users ; **Elderly users, Physically challenged, Uninitiated users and Shoppers with kids.**

**Addressing User Amenities** - The BEV will also cater to the need for better amenities for the target user like **Navigation facilities, Storage space, Easy maneuvering through mall traffic, Flexibility in choices of sitting.**

**Exterior styling design** - owing to timeframe, explorations of the vehicle form are evolved mainly from the **environmental context** of use. Identity of the vehicle could be worked on, for further development.



## Why Supermalls?

- Sudden boom in the market of “Malls” as a concept in India
- Increasing competition between the malls in India to attract more shoppers
- Quality of service provided by the malls is a premium factor of stiff competition
- Cut-throat efforts with strong promotional campaigns and advertising to lure more customers
- Owing to the economic surge in the buying capacity of the working youth in major metros all over India, Malls are now more of a social hub than a shopping experience.

## USER PERCEPTIONS

After intensive user studies and interviews, certain inferences were drawn about the shopper's perceptions of malls



‘Large expansive spaces - I get tired roaming around one mall at the end of the day!’ -  
**Vast areas** of Commercial expanse

“Previously shopping for many things at one go was difficult, malls have everything under one roof!” - Choices for the shopper have increased manifold



© Alfred Molon www.molon.de

‘I am bombarded with a variety of shops’

- Over looking spaces with different **levels of transparency**

“ I love shopping in this air-conditioned mall especially in the hot summer”

- **Controlled indoor environments**

“There are a lot of other things happening like entertainment events with promotional schemes”

- More **interactive environments** with in-your-face advertising



"If I want to buy a gift at short notice, I would like to see all possible options in a short time"

- Easier navigation within the malls, highlighting zones is needed



“The In-orbit mall is so huge, I cant cover all shops in one day”

- Quicker **look at all shops** in the mall is needed



**off the mark**

by Mark Parisi

www.offthemark.com



Female shoppers and little kids are the main target with the promotional aspects of the malls

There are two main types of shoppers:

Leisured shoppers (Window shopping, Social activity)

Experienced shoppers (Frequent visitors)

## Mission: Go to Gap, Buy a Pair of Pants

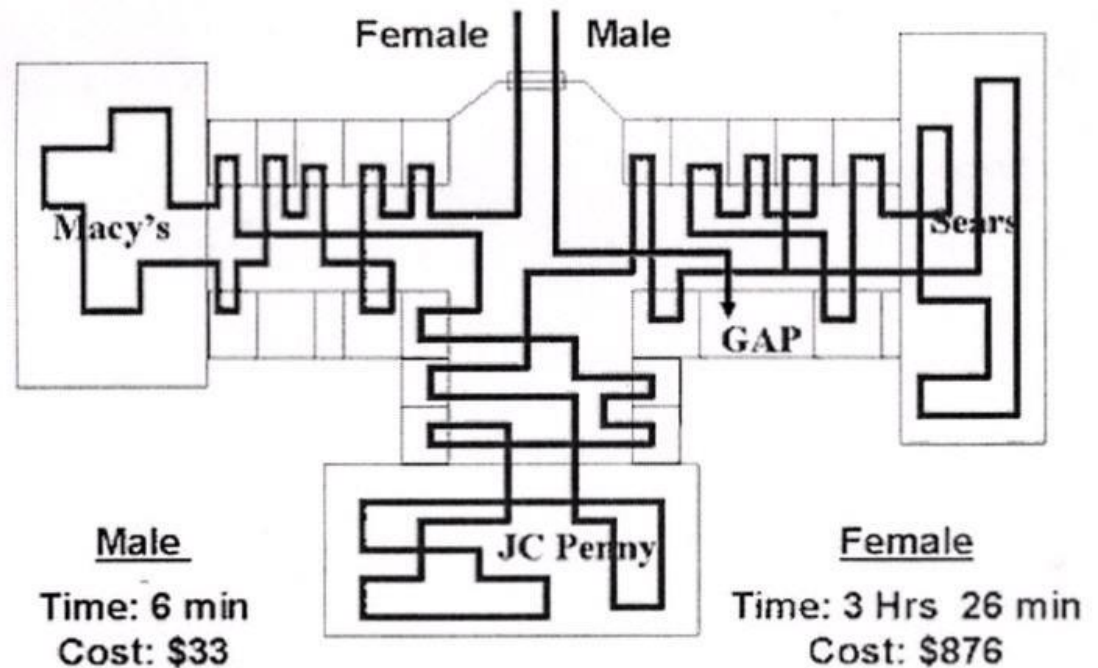

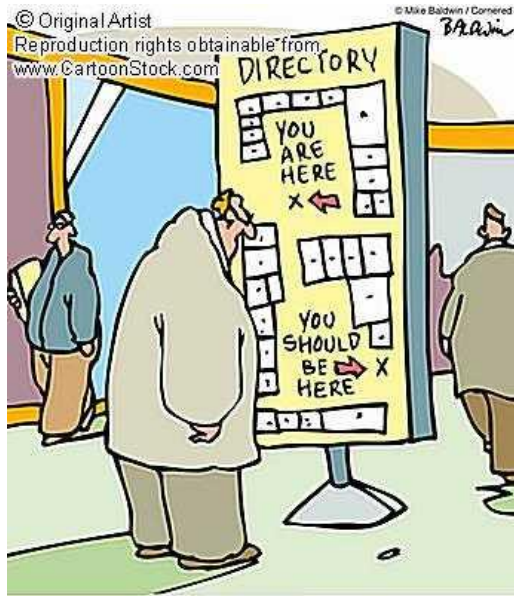

## Why a vehicle for Supermalls?

Existing scenario:

Malls have adapted the existing golf carts in the market with various capacities for passenger carriers



No ideal vehicle designed for this purpose



### DESIGN INTENTIONS:

- To improve the experience of shopping to attract more customers
- Short-distance 'shop - hopping trips' for convenience of shoppers
- Providing an easy transportation solution for the physically challenged and elderly users too
- To help the first-timer to navigate through the mall easily



## Why Battery -Electric -Vehicle?

In the existing context of malls,  
such a vehicle should be:

- **Indoor transportation solution** - EV's rank ideal for this condition
- **Can be refilled easily within the campus limits** - owing to lack of dependence on fuel, EV's are the best solution
- **Zero-emission Vehicle** - EV's are the least harmful vehicle for indoor environments
- **Least noisy vehicle** - Owing to the crowd and ambient noise, the EV does not add more noise to the environment
- **Easy maneuvering through meandering spaces in malls** - **Compact and flexible** solution to be provided
- **Low speed** - Traveling by this mode is just an extension of ambling through spaces - an easy go **leisurely activity**.

# Existing BEV's in various contexts of use



AIR PORT

ALMOST ALL KINDS OF PEOPLE

KIDS

ADULTS

PHYSICALLY CHALLENGED

AIR HOSTESSES

INTERNAL STAFF MEMBERS

THINGS TO CARRY

BAGGAGE

LAPTOP

PURSE

OFFICE BAGS

VANITY BOX

CAMERA BAG



APPROX VOLUME : 450X 300X200 IN MM

# Existing BEV's in various contexts of use



**INSTITUTIONAL OR  
COMMERCIAL USE**

**STAFF MEMBERS**

**EXECUTIVES**

**VISITORS**

**KIDS**

**PHYSICALLY CHALLENGED**

**THINGS THEY CARRY**

**LAPTOP**

**OFFICE BAG**

**TIFFIN**

**FILES AND FOLDERS**

**BOOKS**

**COLLEGE BAGS**



**APPROX VOLUME : 550 x 300x200 IN MM**

# Existing BEV's in various contexts of use



## GOLF

INDUSTRIALIST  
BUSINESS MAN  
EXECUTIVES  
MAJESTIC  
ROYAL

## THINGS TO CARRY

### GOLF KIT

GLOVES  
SHADES  
WATER BOTTLE  
GOLF KIT BAG  
EXTRA PAIR OF  
SHOES



APPROX VOLUME FOR GOLF KIT : 1200 X 400X400 IN MM

APPROX VOLUME FOR A SMALL KIT : 300X200X200 IN MM

# Existing BEV's in various contexts of use



## **SUPER MALL**

**ALMOST ALL KINDS OF  
PEOPLE**

**VISITORS**

**KIDS**

**PHYSICALLY CHALLENGED**

**FAMILY**

**WINDOW SHOPPERS**

**SHOPPERS**

## **THINGS THEY CARRY**

**SHOPPING BAGS**

**GIFTS**

**FOOD PACKAGES**

**BASKETS**

**PURSE**

**COLD DRINKS OR WATER  
BOTTLES**

**CARRY BAGS**



**APPROX VOLUME : 550 X 300X200 IN MM**

One of the contextual studies will be discussed to highlight the following areas:

- ADVANTAGES OF THE BEV
- DISADVANTAGES OF THE BEV
- CONTEXT OF USE
- USAGE RATIOS
- INSIGHTS & OBSERVATIONS



## Study of the Electric Cart used at Nirmal Lifestyle, Mulund, Mumbai

### CONTEXT OF USE

Currently using 8- seater golf cart manufactured by Maini electric vehicle manufacturer.

There is a need for moving vehicle within the super malls for :

- Service
- Luggage transportation
- Security officers
- Passenger transportation



## Advantages of the EV



- Produces low noise
- It is an open car.
- Useful for aged people to move from one place to other.
- For people who are carrying too much of shopping bags or luggage
- It's like a toy train for kids and so it's a main attraction for them.
- Speed limit is only max 25 km/hr, so it's safe for the pedestrians
- The last seat is the main attraction for the kids - sitting in reverse orientation

## Disadvantages of the EV

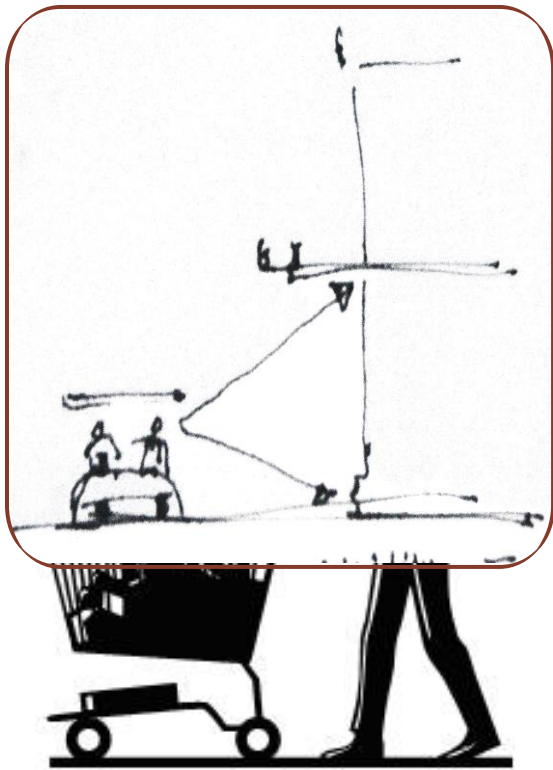

- Horn is placed below and so operated with leg.
- Roof blocks the view of other shops in the building on upper floor
- As being a special attraction for kids there are no such concerns in terms of extra space for kids or any extra provision for kids to seat.
- Too long and straight body and so it cant pass or take easy turns in turning junctions.
- Sometimes people just barge in ,so it becomes over weight & runs slowly which might affect its performance - consumes a lot of battery power
- No provision of storage to keep the luggage or shopping bags
- To stop the cart, passenger has to shout or wave to the driver,
- The same applies when they want to get off from the cart
- The existing vehicle does not cater to physically challenged users

## USAGE RATIOS

The ratio of people per trip derived from the study:

3 kids out of 8 passengers.

2 aged people out of 8 passengers.

3 or 4 number of people who are carrying shopping bags.

\*The person on wheel chair is 1 out of 500 people in the mall

\*The average time one person travel by cart is approximately 5 minutes.

\*The activity of ingress and egress happens in this vehicle approximately 800 times in a day.

## INSIGHTS



- The cart should be open that it gives more visibilities to the other part of the mall.
- The width of the cart is too small in respect to its length and so it vibrates more when u increase the speed.
- The length is too much and so taking turns is not easy in crowded situations.
- No navigation facilities to tell the user where he/ she is

Temporary standing positions for people on short rides

People with wheelchairs cannot use the existing vehicle

Modularity as a principle, would prove to be useful as per the requirement of the context

## INFERENCE

- The design should cater to an open vehicle with good visibility
- Easy ingress into the vehicle will ease passenger traffic
- Driver as a secondary user has not been catered to in the existing design - storage space, easy accessible controls, ergonomic comfort
- The design includes modular design with junctions which provide flexibility for taking turns
- Modularity will provide opportunities for catering to different user's needs - physically challenged, elderly users and first time visitors
- Modularity will simplify the manufacturing process

## FINAL CONCEPT

- Introduction of a new posture - half sitting posture for short distance rides
- Modular design with passenger carrier
- Providing gripping surfaces for safety while riding

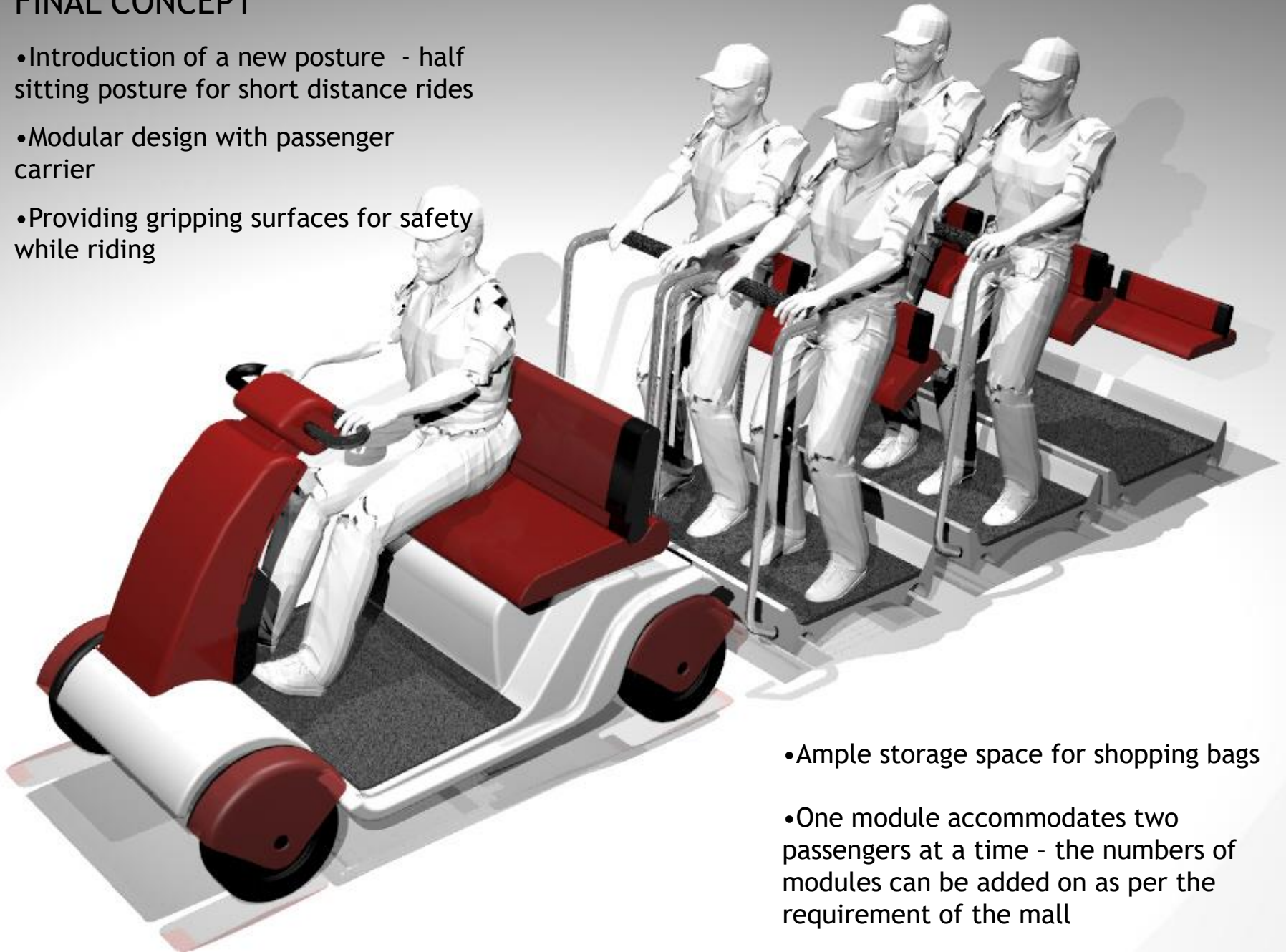

- Ample storage space for shopping bags
- One module accommodates two passengers at a time - the numbers of modules can be added on as per the requirement of the mall

# DRIVER CAR

Open to sky design for better visibility

Fold-down arm rest for co-passenger

Folded ridge provided for better strength

Added storage space in front

Fenders provided for protection and carry the same visual language



# TOP VIEW

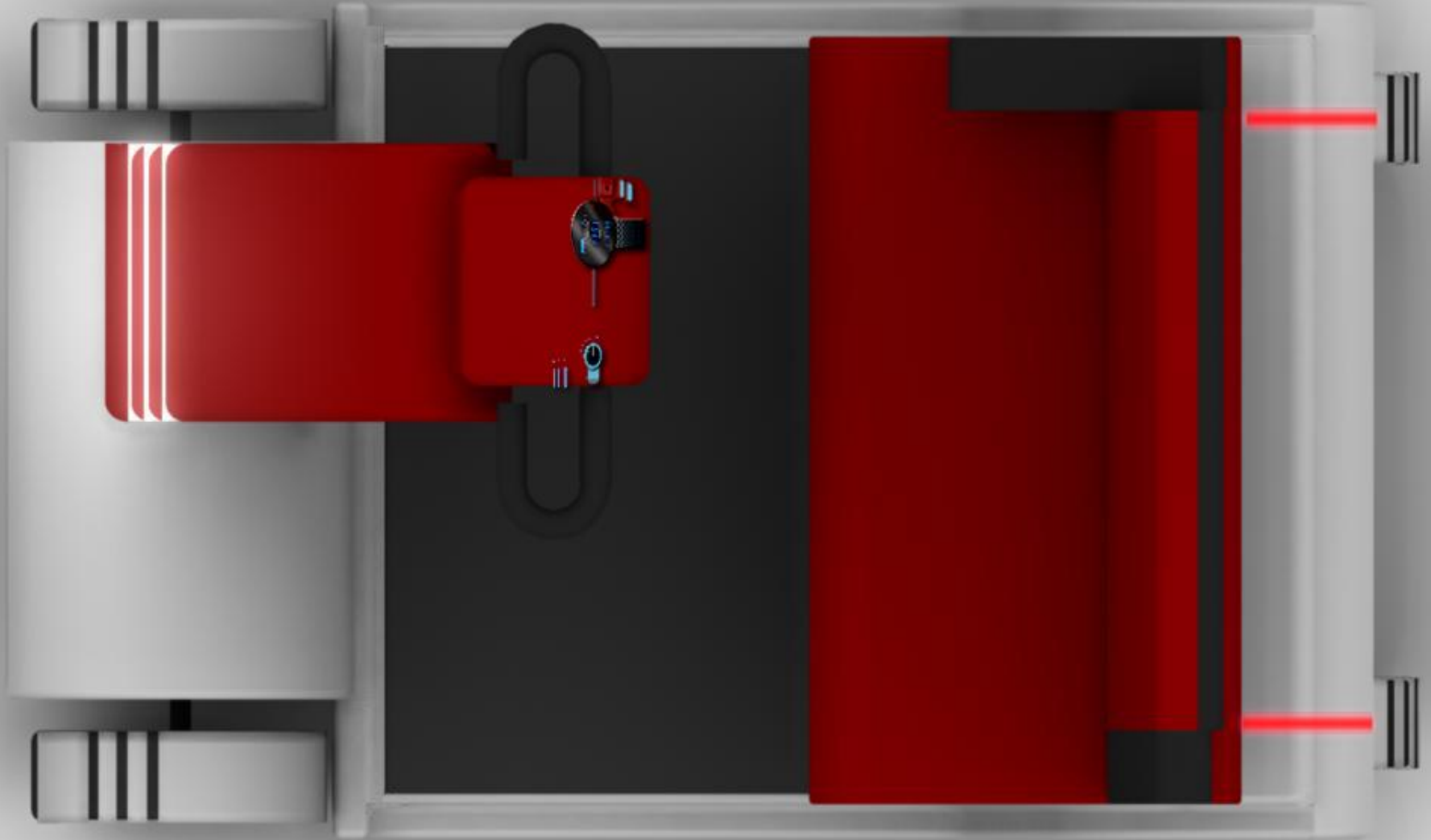

Refreshed instrument panel with navigation screen and manually operated ZONE indicator

FRONT VIEW



Flexible [steering](#) column to adjust to different drivers who use the car

Steering column acts as surface for publicity / monogram

Break away from the typical steering wheel - identity of a BEV

Easy access to the battery placed under the driver's seat

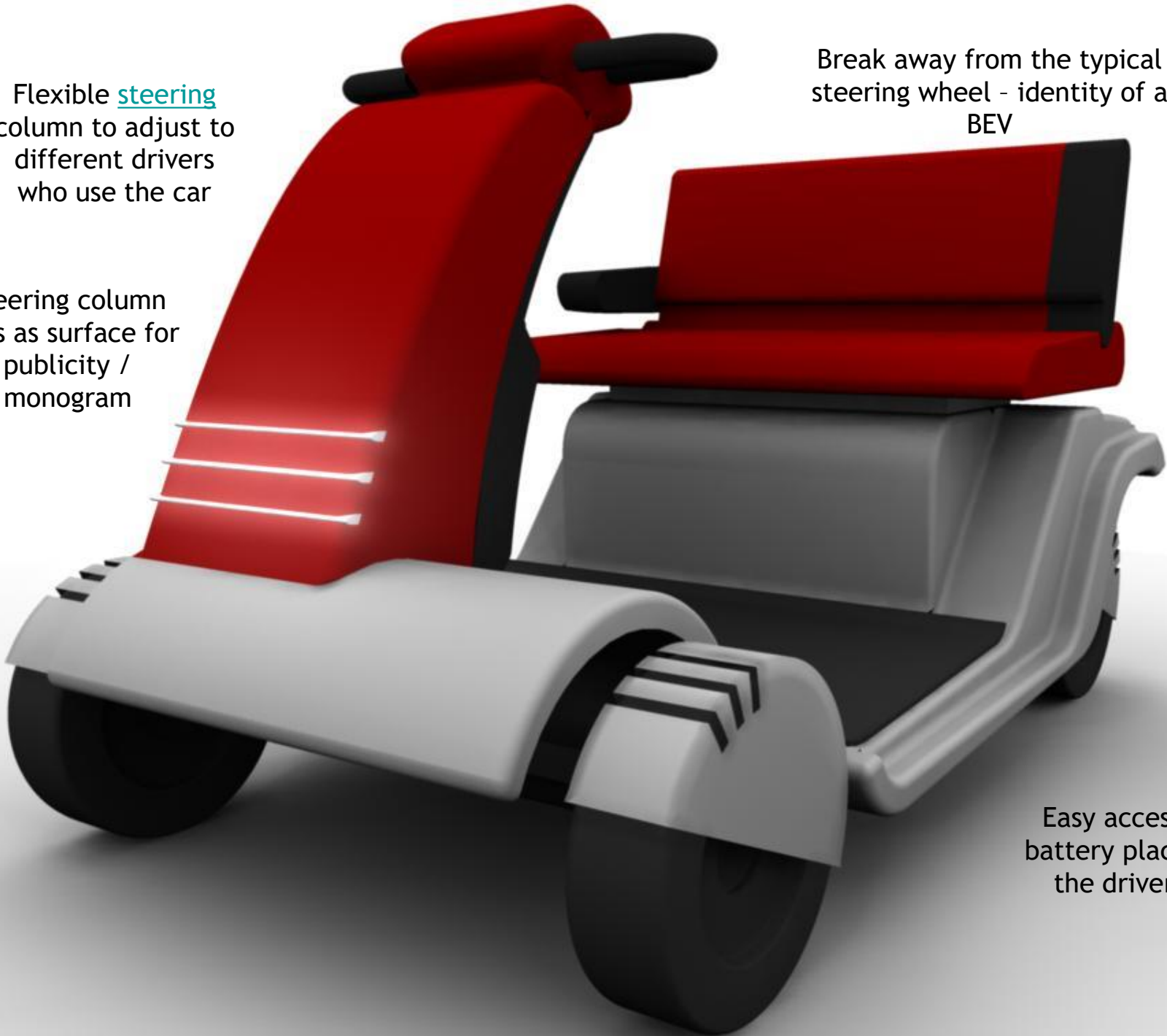

Assuming that floor levels are even, the decision to lower the ground clearance making it inviting and easily accessible

Seats are upholstered in rexin for easy maintenance

Owing to meandering paths, the use of castor-design wheels aids in flexible movement

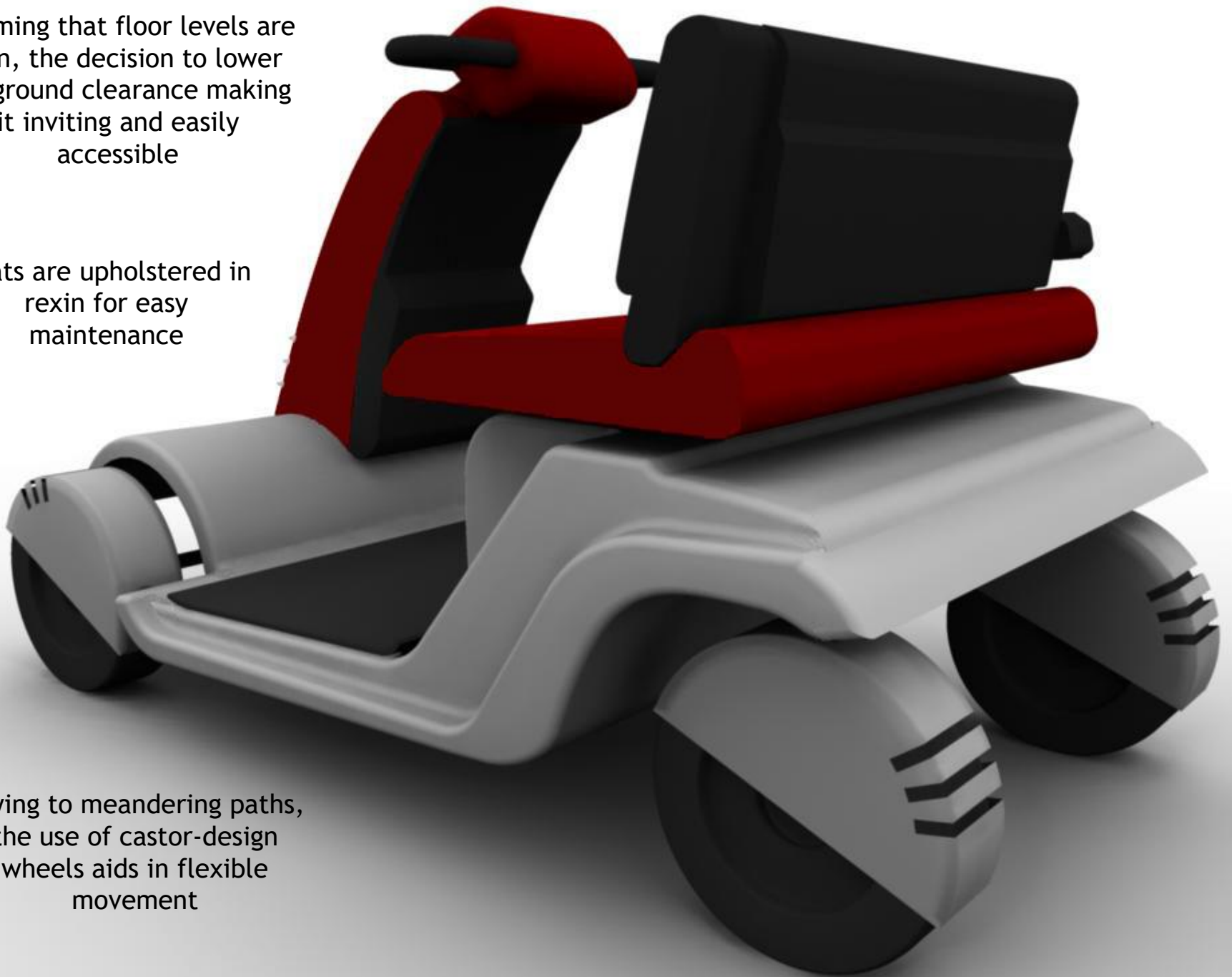

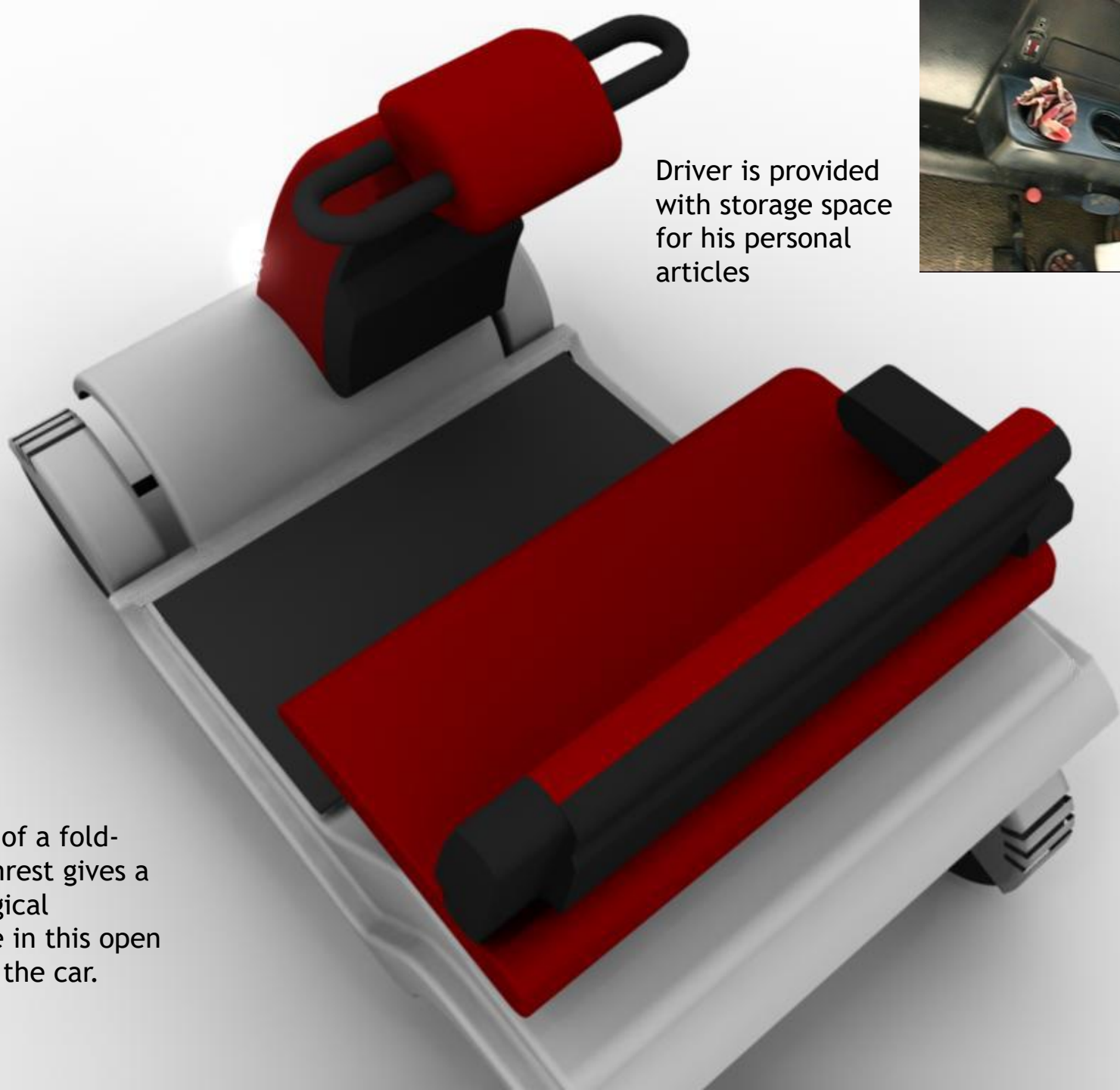

Driver is provided with storage space for his personal articles



Provision of a fold-down armrest gives a psychological assurance in this open design of the car.

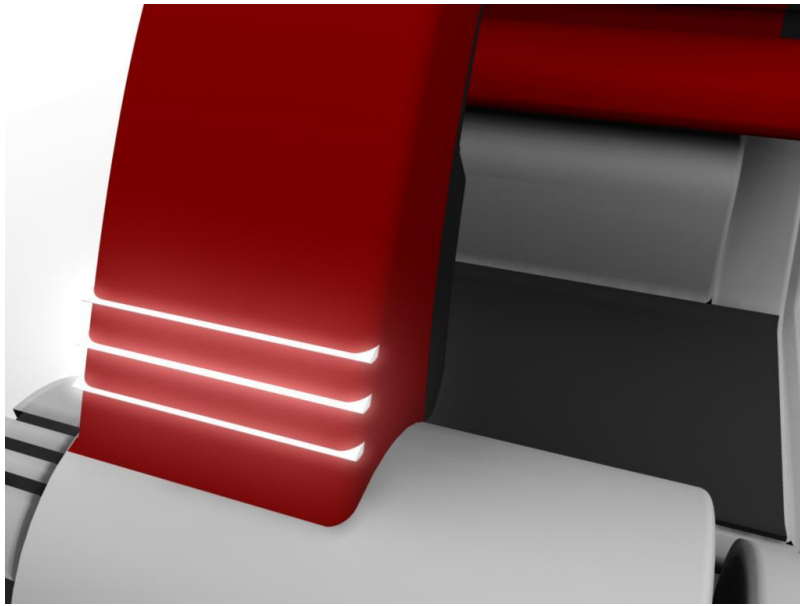

LED lighting panels used for front cowl to break the visual vertical monotony and it follows the same language of the other elements like the fenders.

Keeping in mind the “light pollution” at these malls, LED’s were employed

LED’s have lesser electrical consumption and are more durable

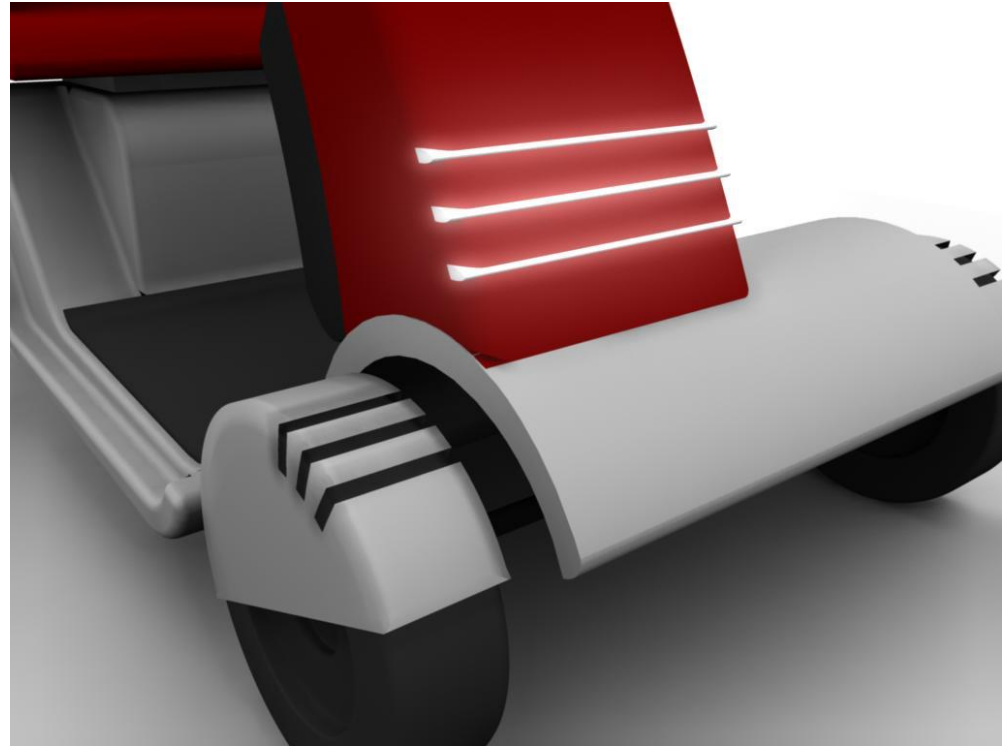

# EXPLODED VIEW

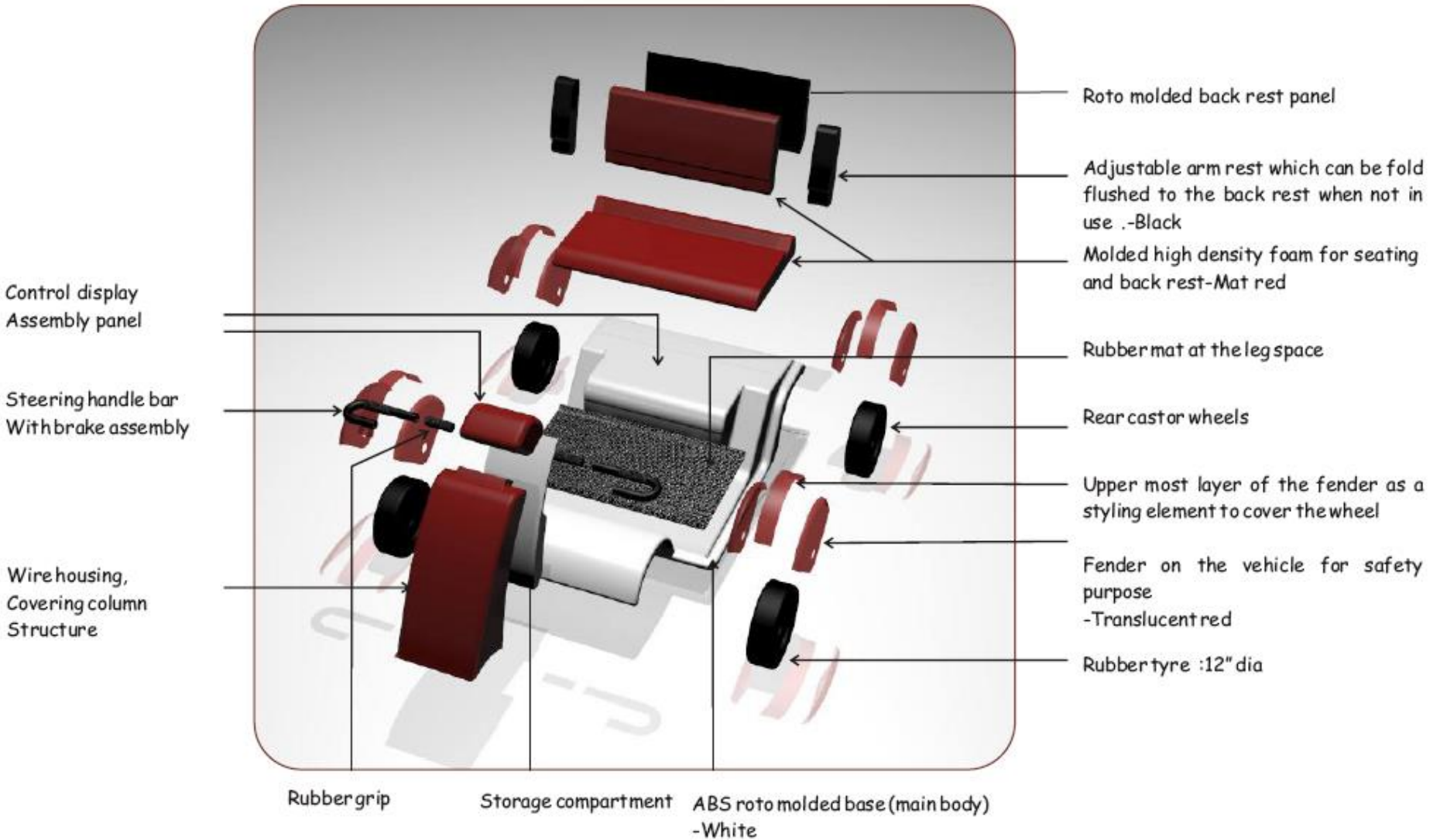

## CASTOR-DESIGN WHEELS



This 4 wheel steer cart allows a series of carts to be linked in a train. All carts in the train will follow the path of the first cart.

### Mechanism:

-Linked steering mechanisms on front and rear axles enable unit to track the tire tracks closely of the pull vehicle

-The sharpness of turning is limited to under 45 degrees

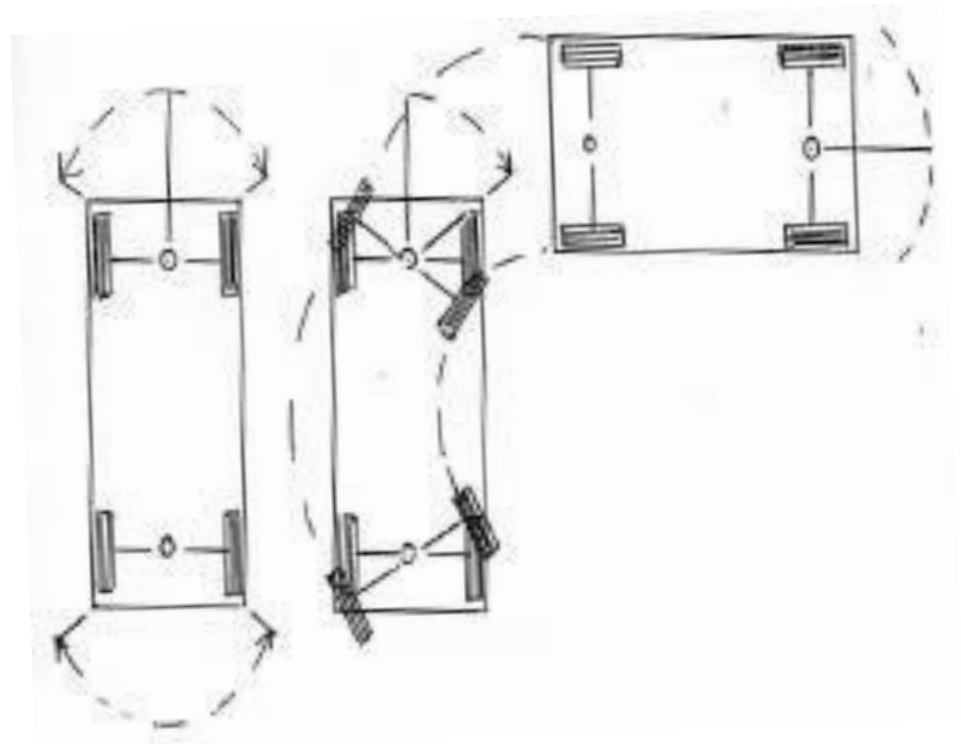

## SEATING DESIGN

Driver's seat position is lowered to enhance visibility of passengers seated behind  
Three permutations are possible with this module:

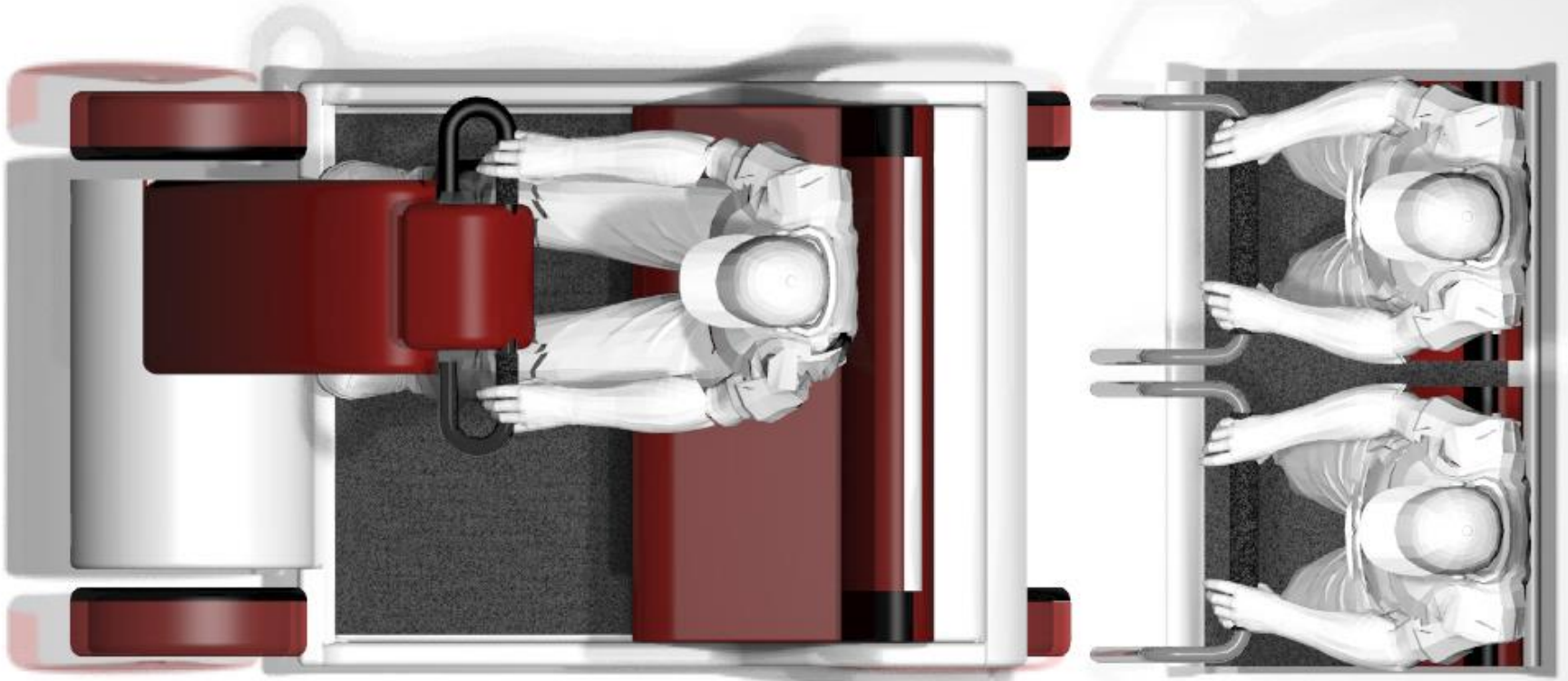

- a) Spacious platform along with the provision for one physically challenged passenger on a wheelchair / passenger with shopping cart or baby stroller
- b) Two-seater design with provision for storage of shopping bags in front
- c) Two passengers standing / half-sitting with provision for storage of shopping bags in front

# INSTRUMENT PANEL

New features were added after the user study:

Introduction of the speedometer

Internal communication system - to communicate with security staff as well as pick-up points



Easily visible battery - power indication

Reverse - forward knob

Handle bar form - with throttle in grips

Initial explorations for instrument cluster

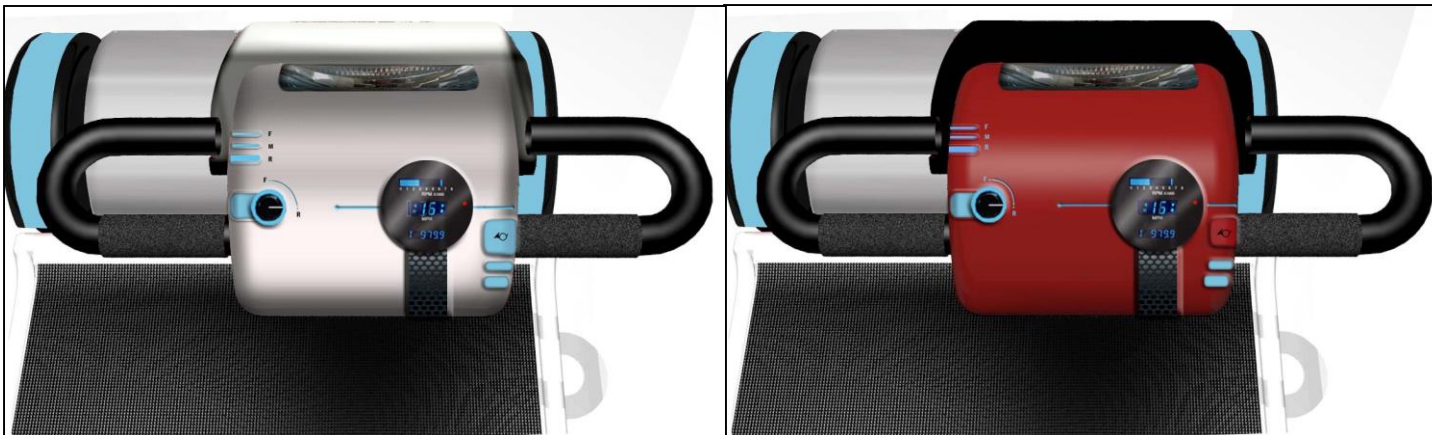

## INSTRUMENT PANEL

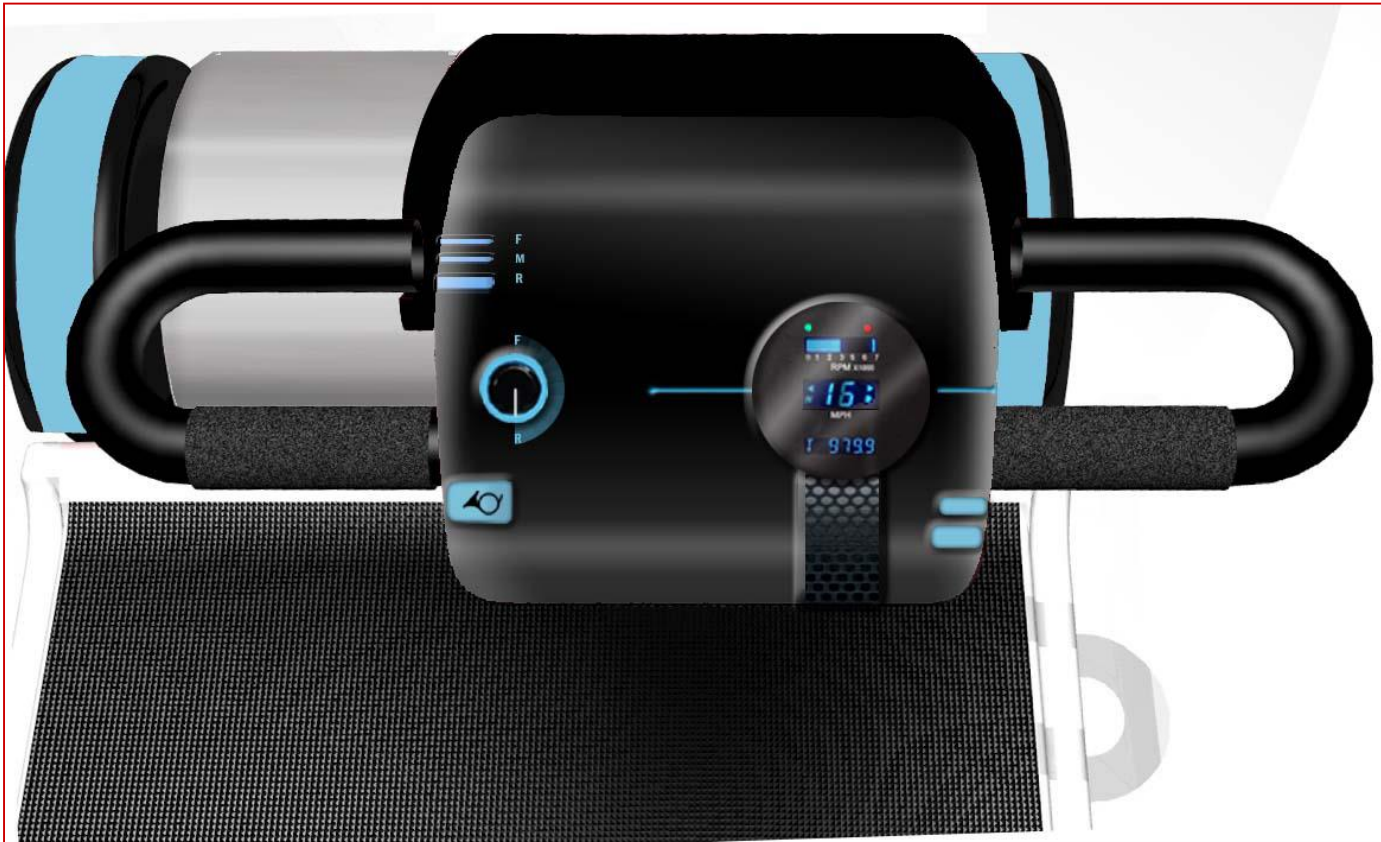

- Easily accessible horn button
- 3 indicators which glow for stopping at desired drop-point
- Time indicator for driver's information
- Two-way wireless communication system which reduces ambient interference - for clear announcements

## INTERACTION PANEL FOR PASSENGERS



- Realtime digital display for advertisements and special offers at various outlets
- Map of ZONES in a mall to help user know different areas
- On-going announcements for specific drop-point stops
- STOP button to indicate to the driver to halt at the next drop point

## DESIGN EXPLORATION AND DEVELOPMENT

- Basic layout designs
- Initial exploration with different permutations in the driver car and passenger car
- Concept evaluation

# COMPONENT LAYOUT DESIGN

Options for layout of battery unit and controller with steering mechanism were explored

Owing to the tight situation of riding through meandering spaces

Steering is electrically controlled.

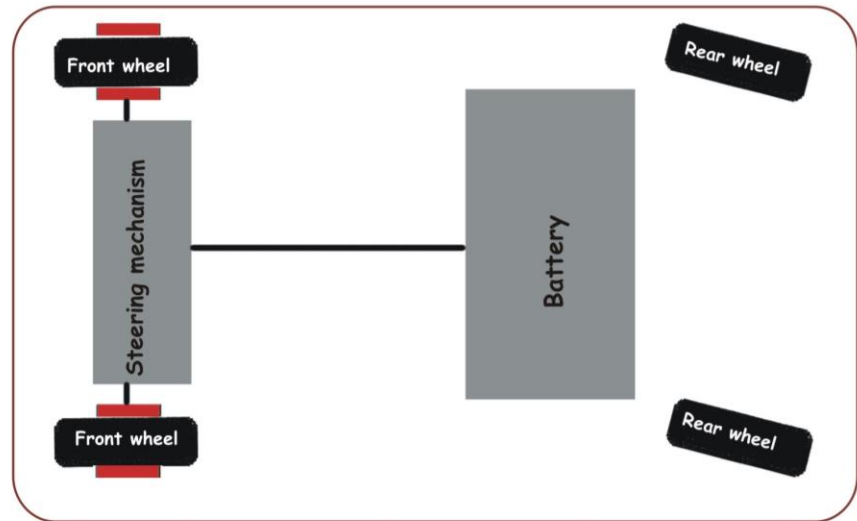
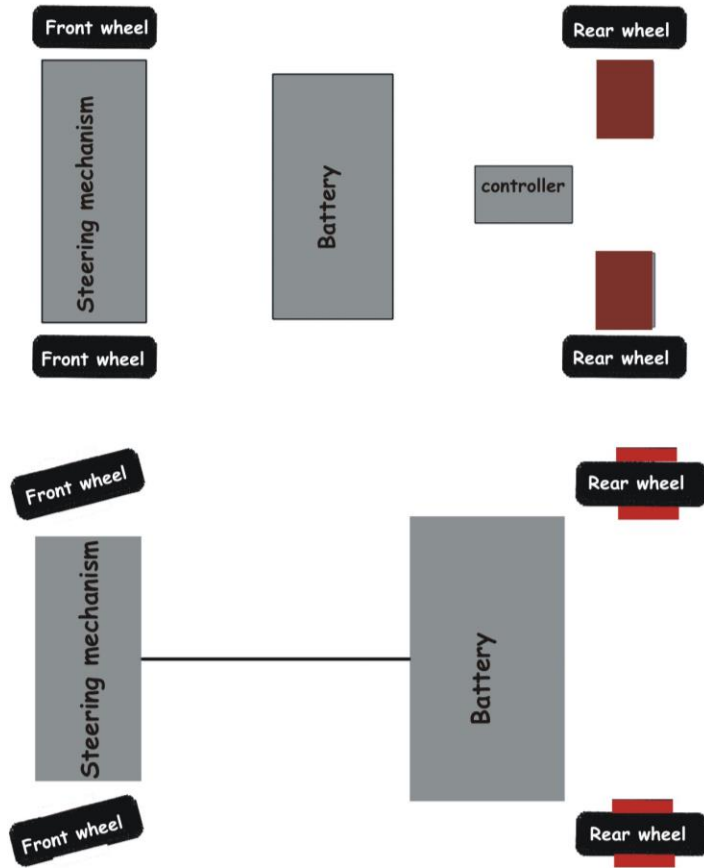

# CONCEPT SKETCHING - IDEA CLUSTERS

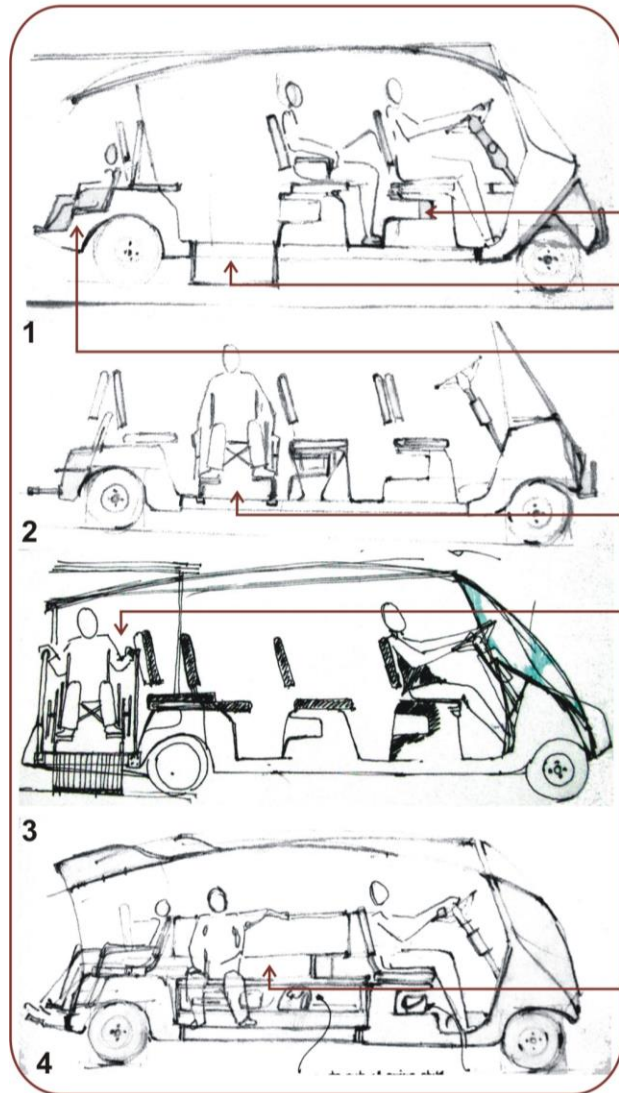

To put personal belongings like shopping bags ,or carry bags or purse

Ramp coming from the cart

Rear seat for the kids with a small seating.

Second last seat for accessibility. And so it has more leg space.

Image showing the rear most module given for the accessibility.

The middle most seats are provided to seat side ways ,providing that person can have better view of the shops and get down immediately.

# CONCEPT DEVELOPMENT - DRIVER CAR

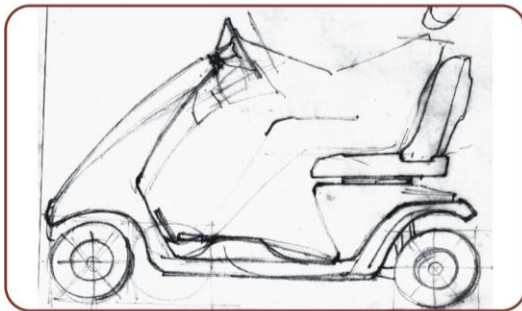
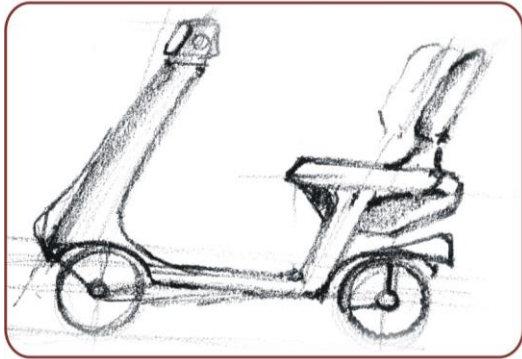
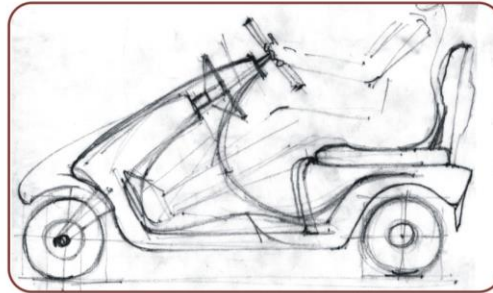
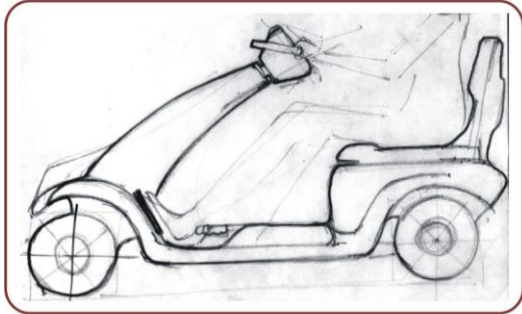

Clusters are to show various possibilities of the relation between steering, leg-space and the seat in respect to the comfortable posture

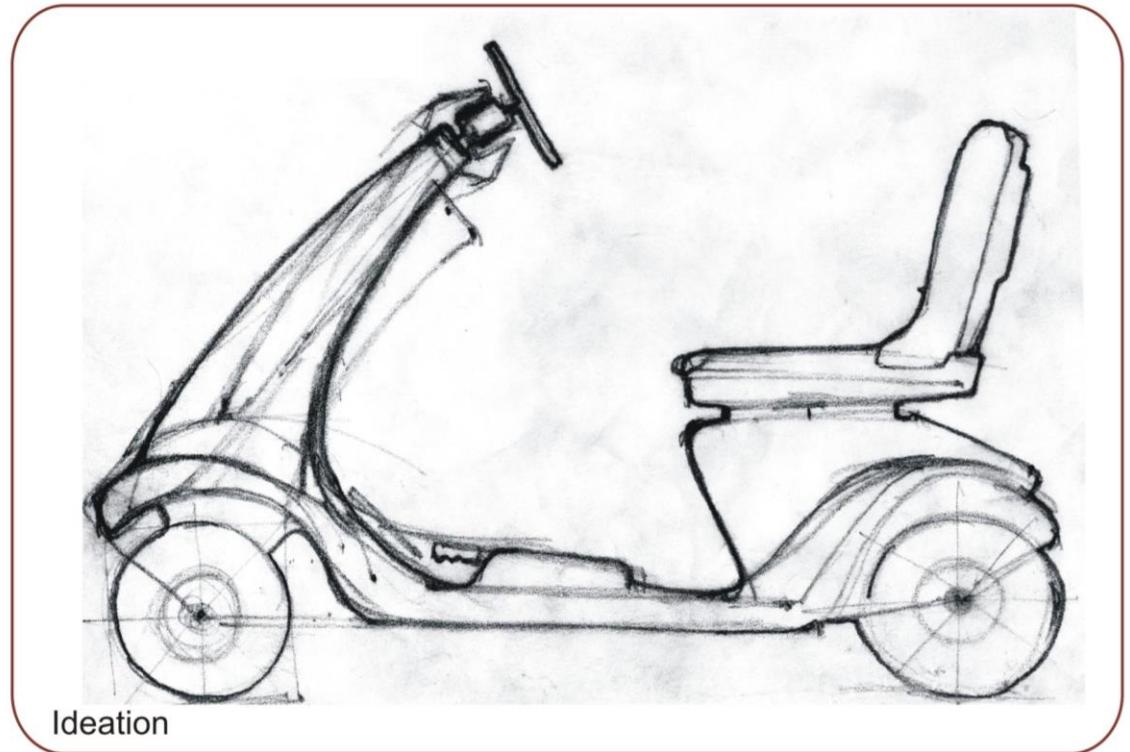

Ideation

## CONCEPT DEVELOPMENT - DRIVER CAR

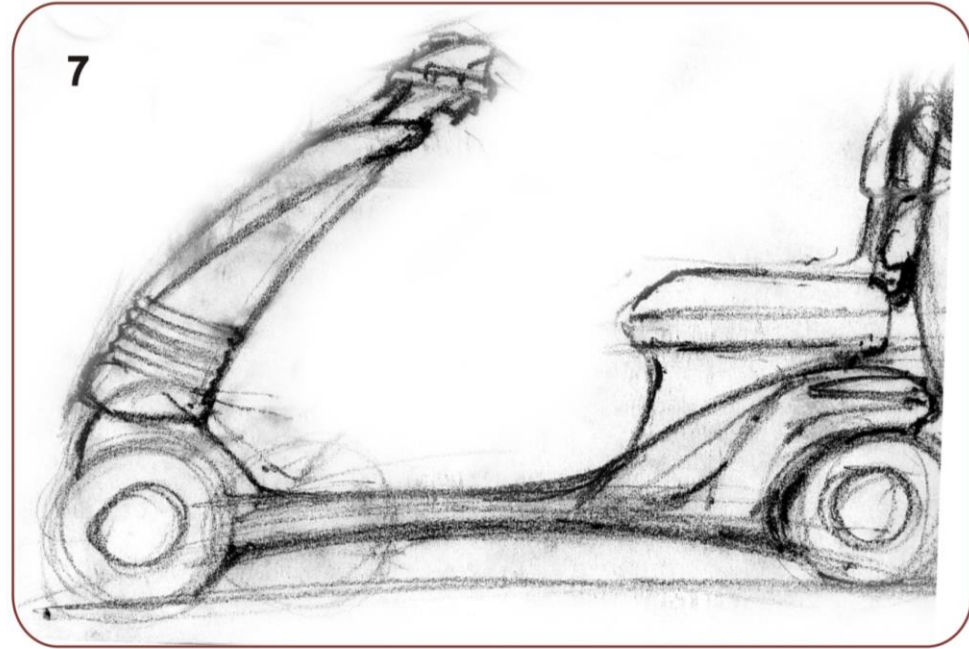
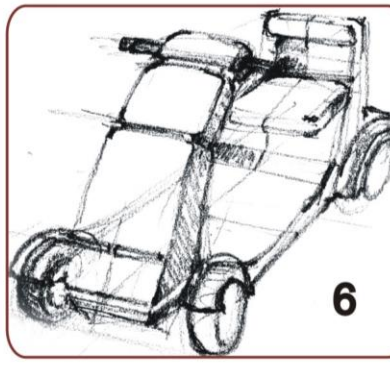
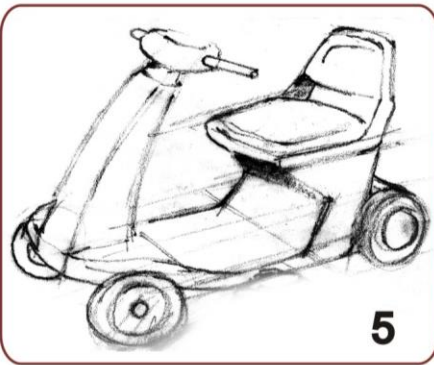
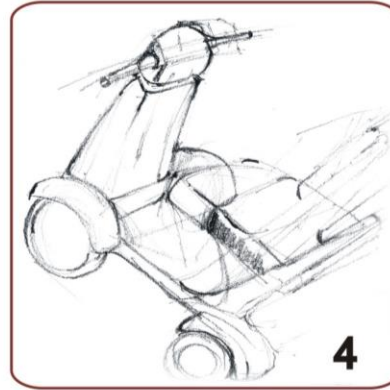
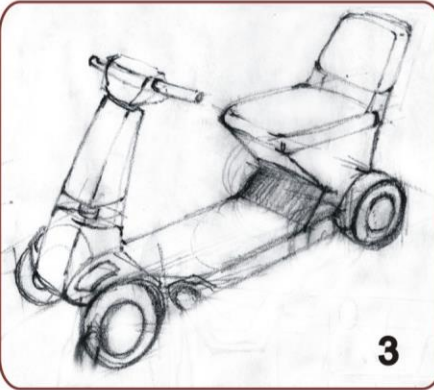
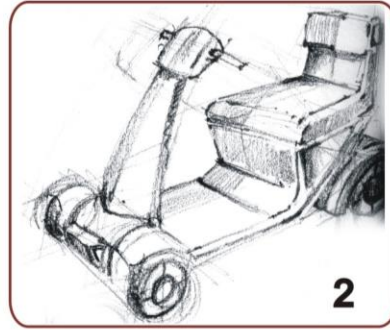
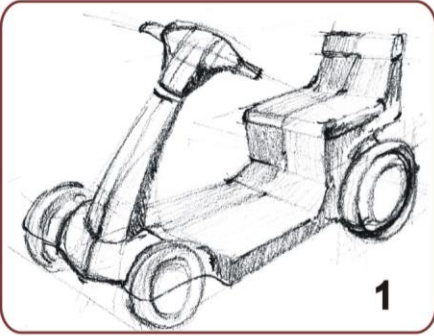

Initial attempt to design a single-seater for a driver which will be attached to the main passenger cart

Form is derived from the product brief where it includes all the requirements that are identified from the user studies.

The main factor of vehicle being adoptive to any size of user.

And so on all the aspects idea 7 is been selected for further development of the concept.

# DRIVER CAR CONCEPT



# DRIVER CAR CONCEPT



# CONCEPT DEVELOPMENT - DRIVER CAR - front cowl options

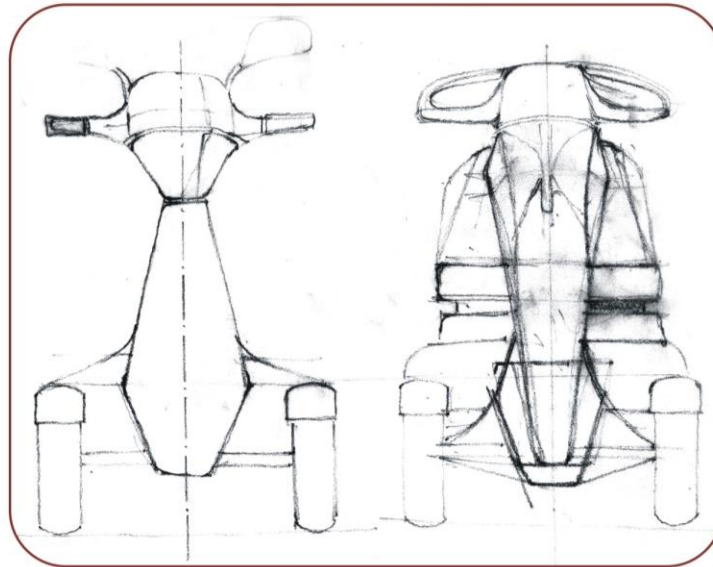
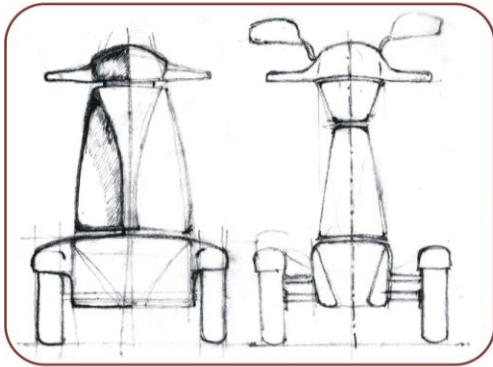
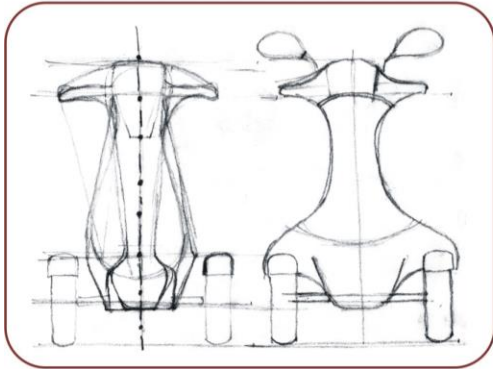

Various possibilities tried out for the front elevation of the cart

Initially one has trying to make the driver car a single seater. And so with identified dimensions and requirement of the size one has arrived to one of the concept as shown in image number ----

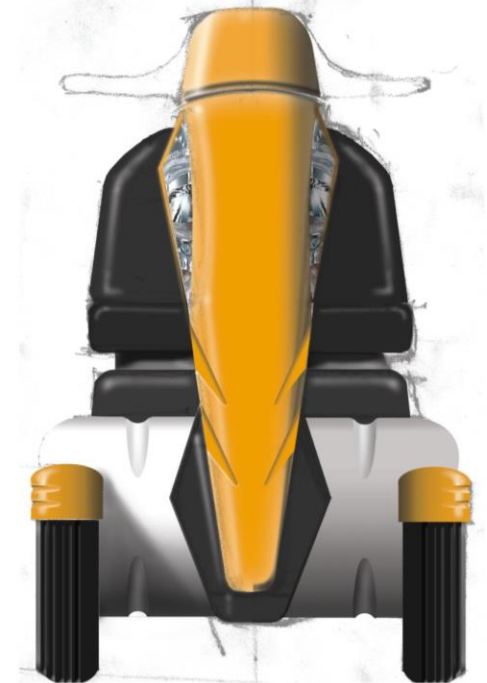

# CONCEPT DEVELOPMENT - DRIVER CAR - front cowl options

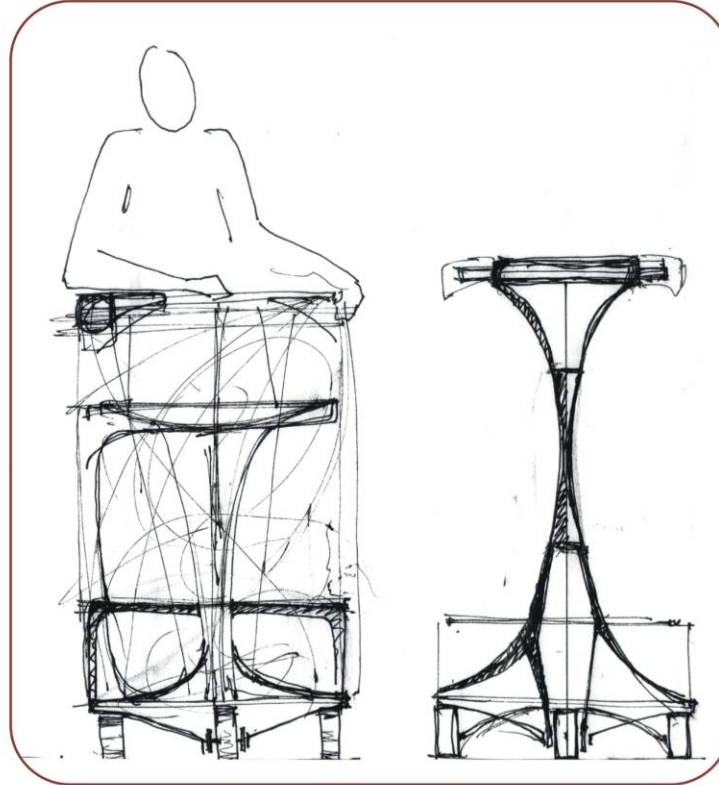
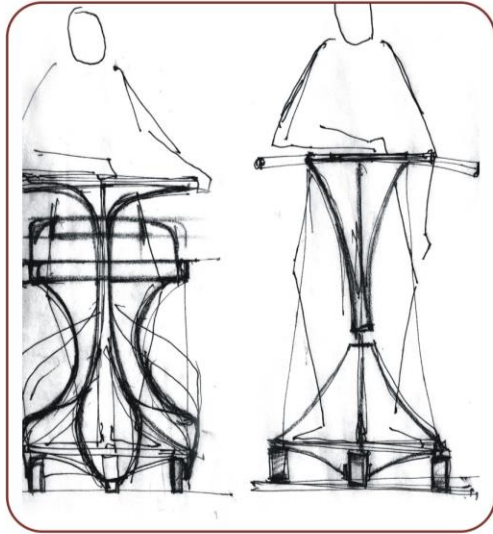
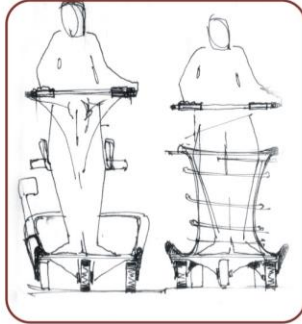

Various possibilities worked out for a passenger cart in respect to the posture study that has been done and few identified postures are taken as a reverence for designing.

# CONCEPT DEVELOPMENT - PASSENGER CAR - USER STUDY

A small study of how people carry their kids and come to visit the malls

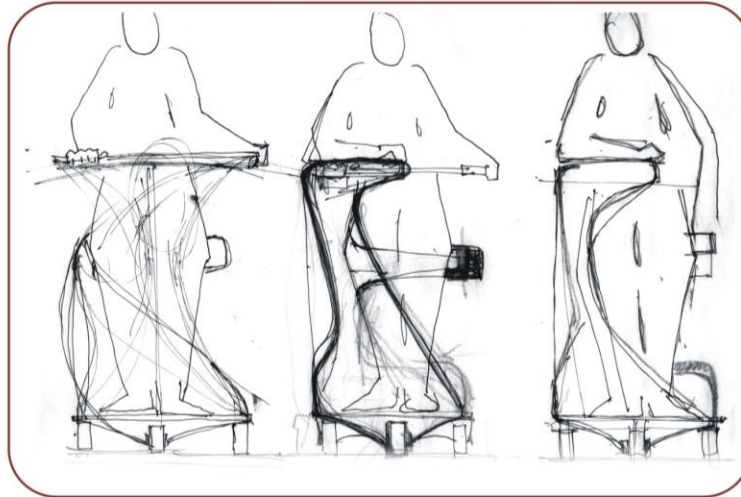
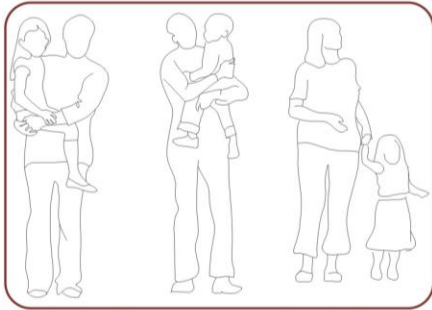

Carrying in their laps ,on the shoulders ,inside the stroller or kids walking individually,But in all the case kids need to be closer to their parents

# CONCEPT DEVELOPMENT - PASSENGER CAR - ROOF OPTIONS

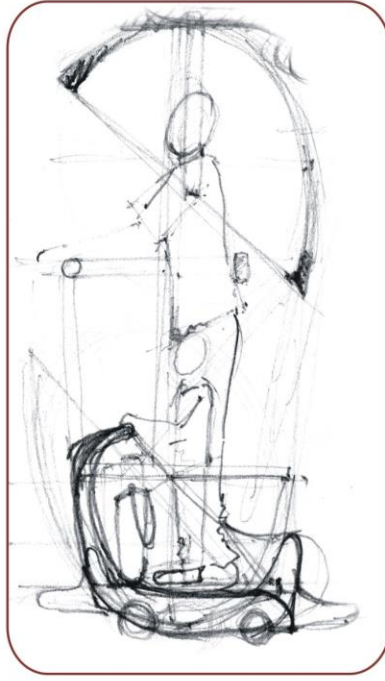
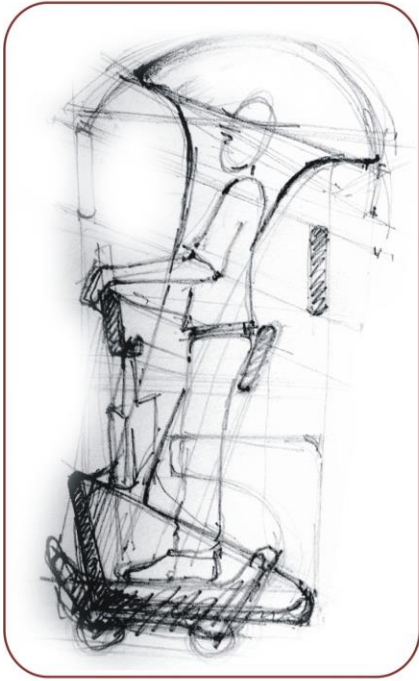

One is trying to explore various possibilities of passengers' cart

Providing a temporary structure to prevent one from the shade or rain

A small railing for a kid to hold on to

Image 3 is trying to explain about a small baby carrying bag attached on the cart where u can even put your shopping bag ,which will be provided on the side

# CONCEPT DEVELOPMENT - PASSENGER CAR - POSTURES ACQUIRED

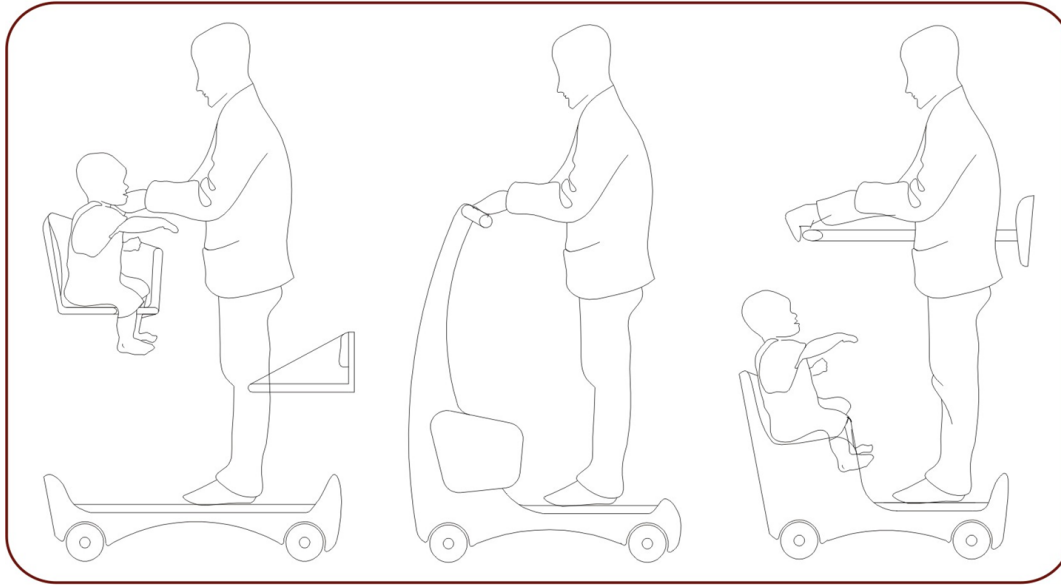

Options for placing small children in front carrier while riding were explored

Storage space is also provided for shopping bags - at different positions to see the appropriate solution

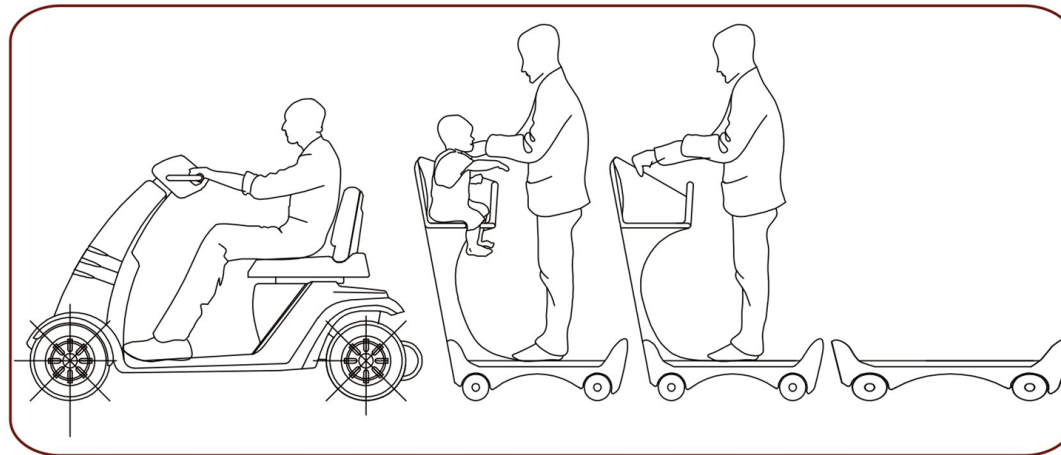

## RIG USED FOR ERGONOMIC STUDY



Mock up rig showing the minimum area required for a single person to stand

# PASSENGER CAR CONCEPT



Various possibilities tried out for the front elevation of the cart

Initially one has to make the driver car a single-seater.

Attempt to arrive at concept keeping in mind dimensions



# CONCEPT ONE - PASSENGER CAR

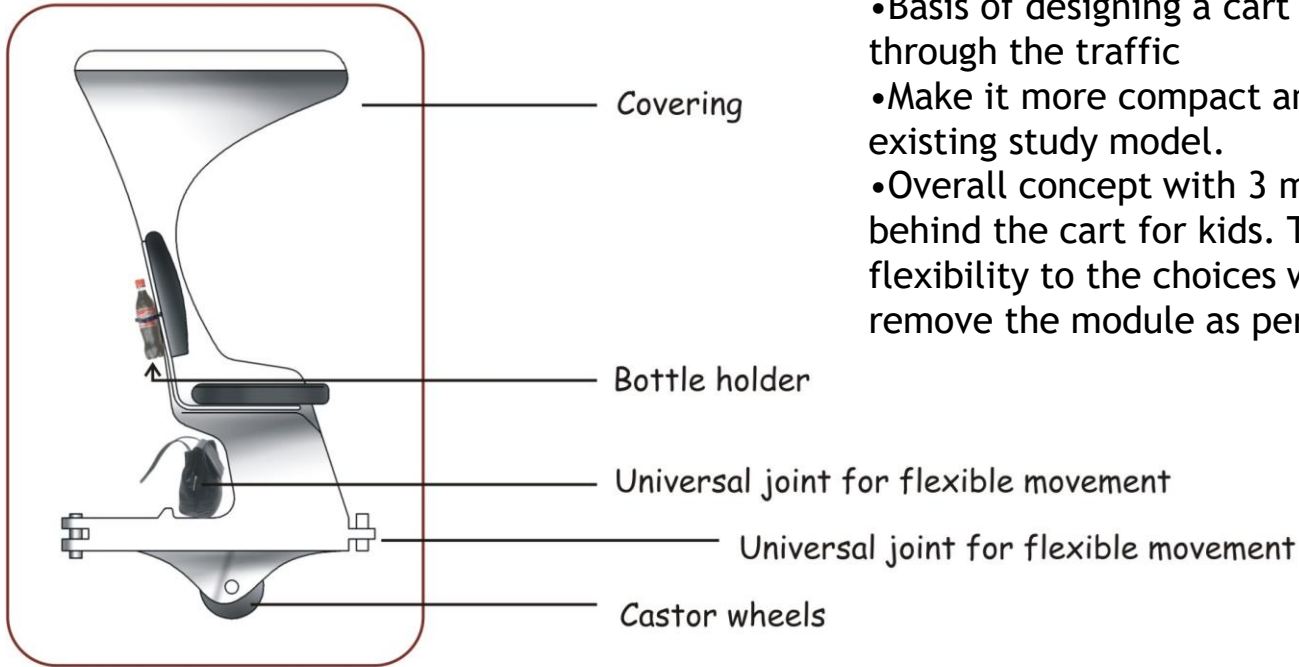

- Basis of designing a cart which can move easily through the traffic
- Make it more compact and short as compared to the existing study model.
- Overall concept with 3 modules with a small seat behind the cart for kids. The modular design gives flexibility to the choices where one can attach or remove the module as per number of people required.

Single module for two person next to each other

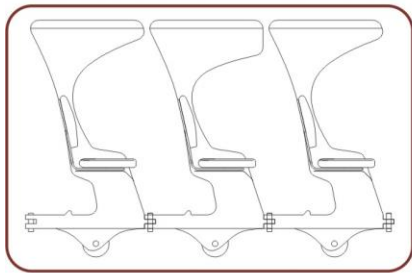

3 modules together attached to each other with a flexible joint

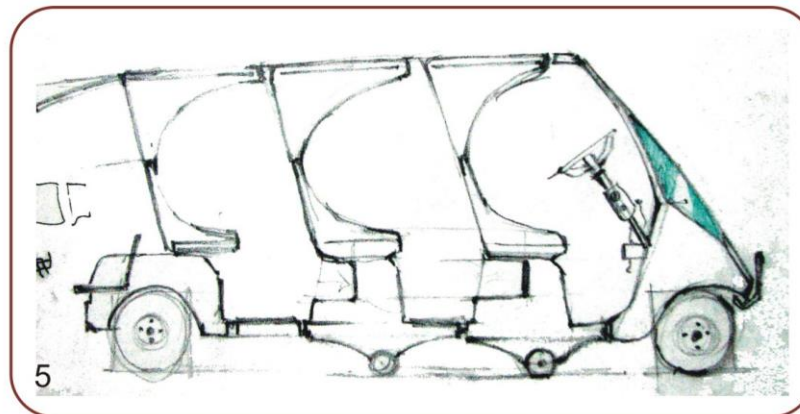

The entire module can be roto molded and it can be mass produced

## CONCEPT TWO - PASSENGER CAR

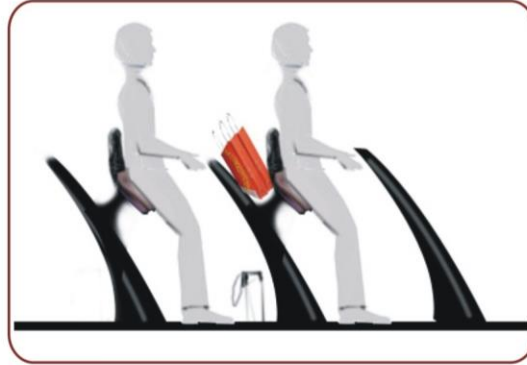
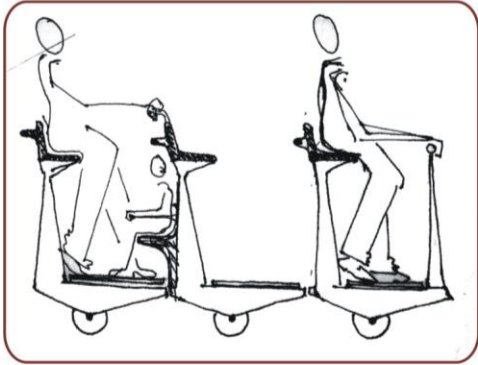

A high seating just to lean on and a space to put the luggage some space near to leg room to put extra stuff

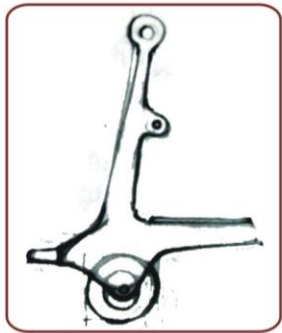
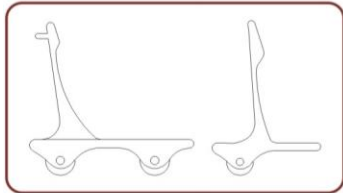

Ideation

A passenger cart for various possibilities to put their stuff and also extra low seating space for kids.

As the traveling is not more than 5 minutes (Average) per person. There is one more idea worked out to provide a platform where person can just stand and its going to help decreasing the space that one person required on the cart.

A high seating provided for a temporary resting. A handle bar provided on the front module. Each module will be having a castor wheels so that it can even move on undefined path. A rubber mat is provided for better grip.

## CONCEPT THREE - PASSENGER CAR

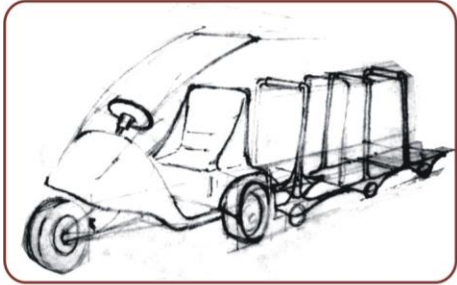
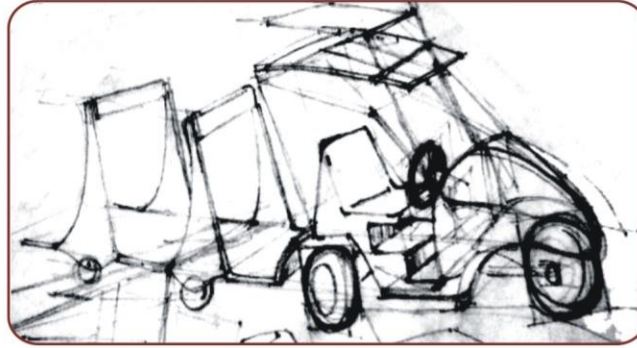
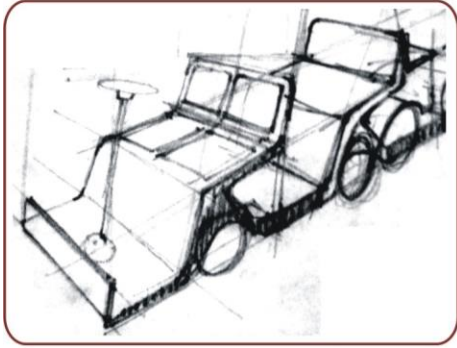

The concept is developed further by including all the ideas mentioned above and also providing the last module for accessibility.

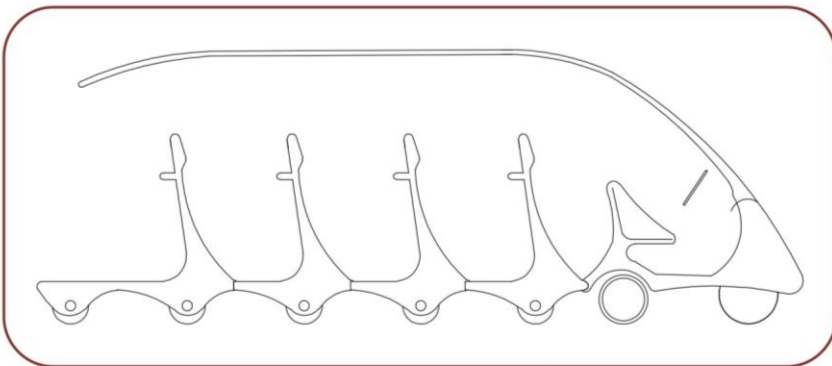

The idea of providing platform to the passengers where they can stand

Few ideas where the front car for the driver can be a compact module on three wheels .having a shade on top it

Then all the other trolleys attached to it as per capacity of the passengers .

Where it can have a back rest and a small projection from the arm rest side and some space below to put the belongings

The module in front will have an handle to hold on to behind the back rest.

# CONCEPT EVALUATION

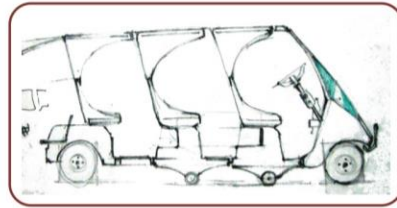

Concept 1

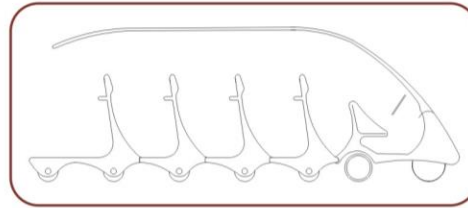

Concept 2

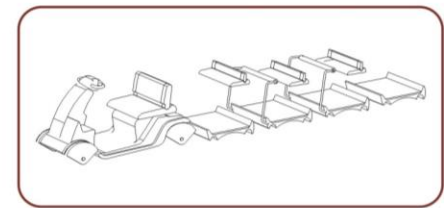

Concept 3

Utilities	6	2	7
Aesthetics	5	6	6
Applications for the context	4	6	8
Compact	3	6	6
Flexibility during movement within the context	3	3	3
Total	21	23	<b>30</b>

Ratings here tabulated are on a scale of 1 to 9.1 being the lowest and 9 being the highest rank.

Since concept 3 has scored the highest rating, this was selected for further development in terms of exploratory models and renderings.

# LIGHTING OPTIONS FOR FRONT COWL



## AMENITIES EXPLORATION

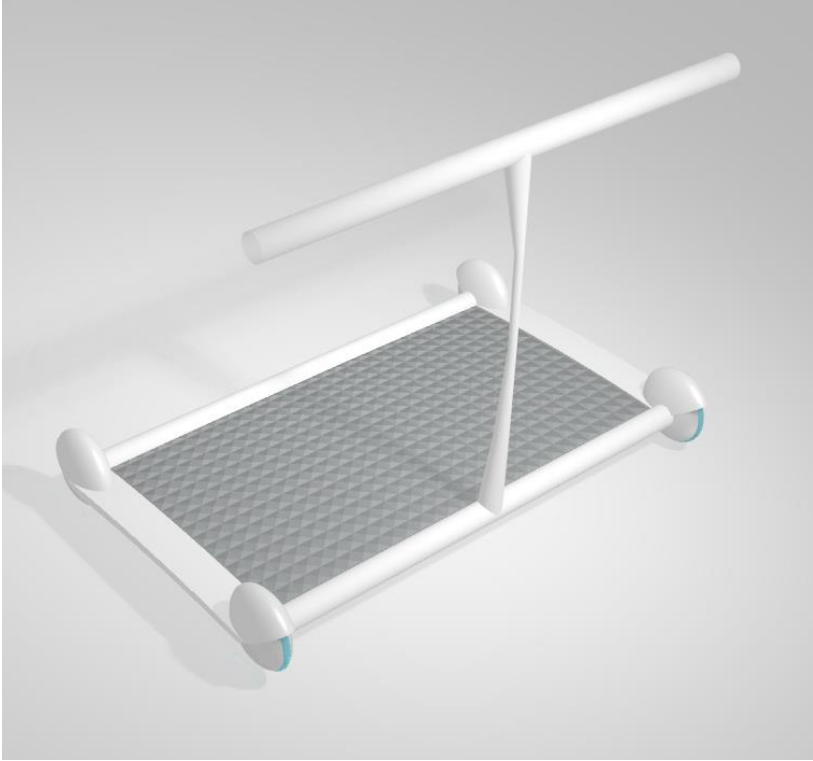

- Rubber flooring for better grip
- Castor wheels for better movement
- Long handle bar explored for holding while standing

- Storage space in front for the shopping bags
- Display LCD panel for realtime information of offers and news updates
- Half sitting posture acquired with bottom- rest
- Gripping surface for safety while riding

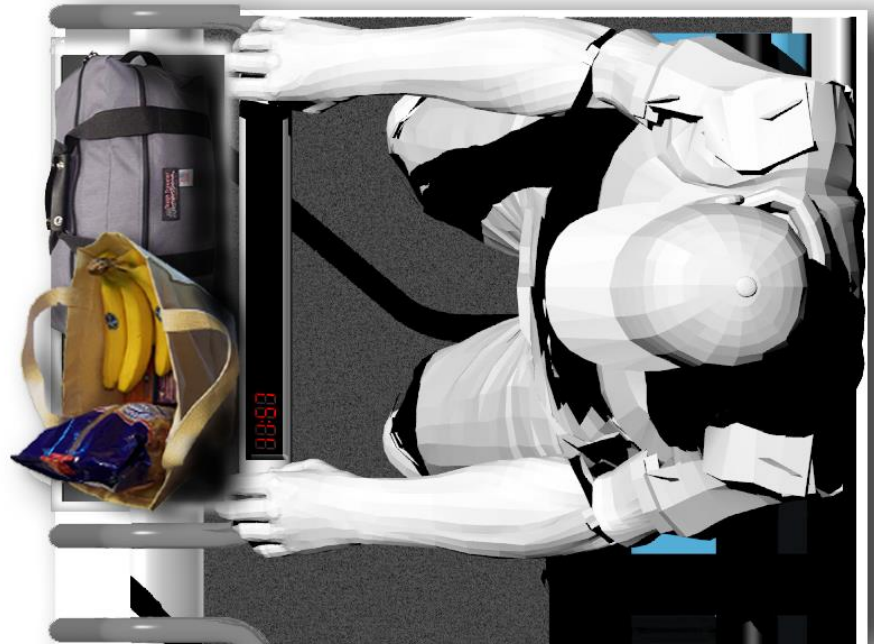

# DIMENSIONAL DRAWINGS

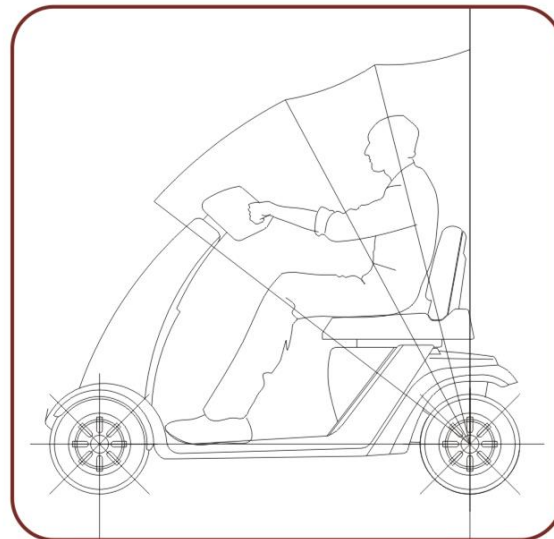
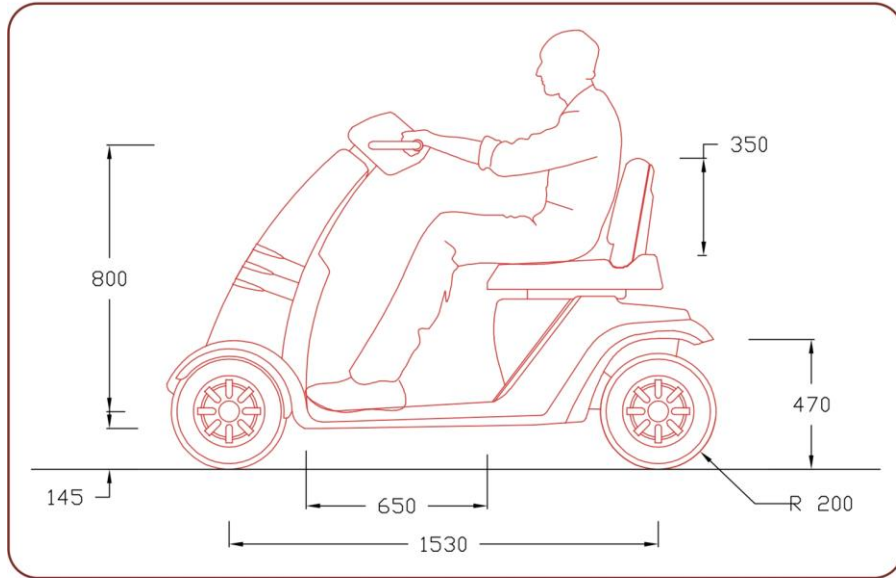

Retractable canopy



A shell made of acrylic

# DIMENSIONAL DRAWINGS

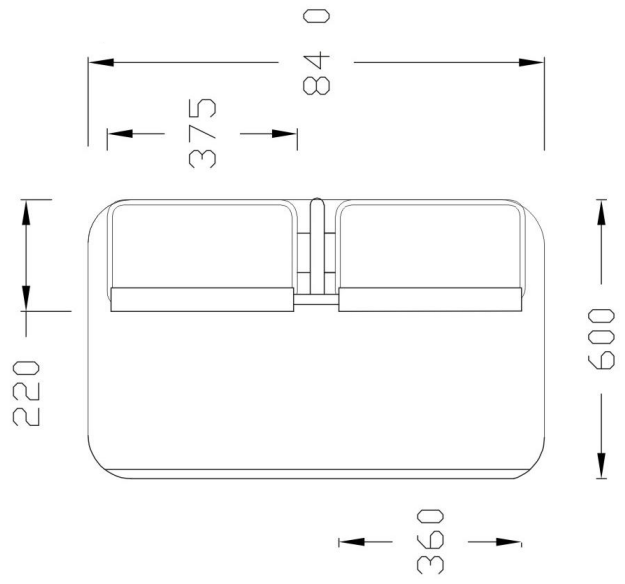
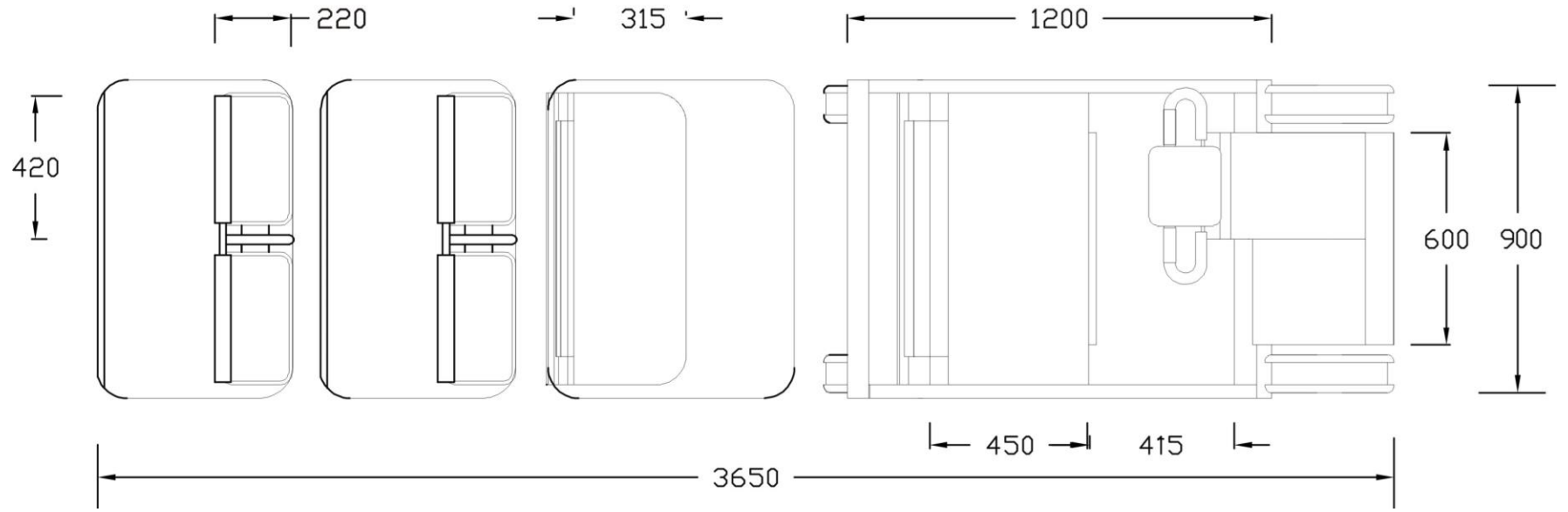

# DIMENSIONAL DRAWINGS

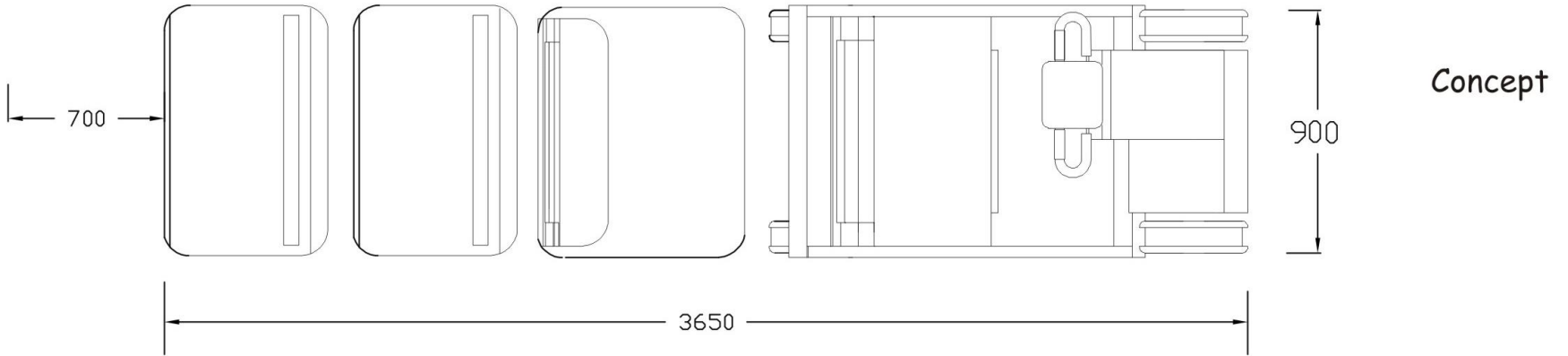
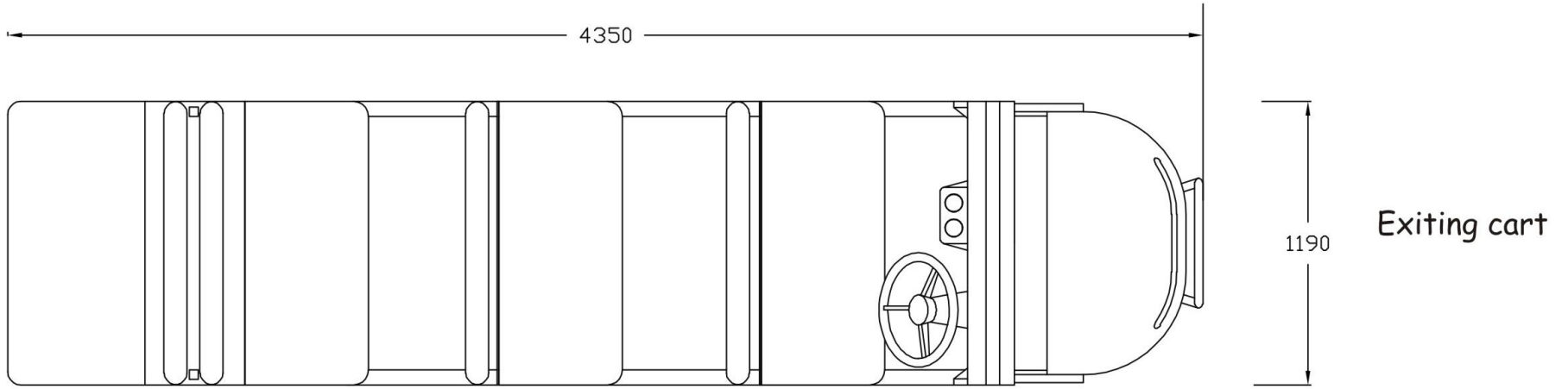

THANK YOU