

PROJECT 3

SURGEON FRIENDLY BIOPSY
DEVICE AND TISSUE
COLLECTION DEVICE FOR
CANCER DIAGNOSIS

BY SRIDHAR G

GUIDE : PROF V BAPAT

CO-GUIDE: PROF B RAVI



INITIAL BRIEF

To redesign a reusable soft tissue biopsy device handle using bolt and nut mechanism, the device should use existing bard coaxial needle, easy to use (pid) , ergonomic, easy to sterile and low cost manufacturing.

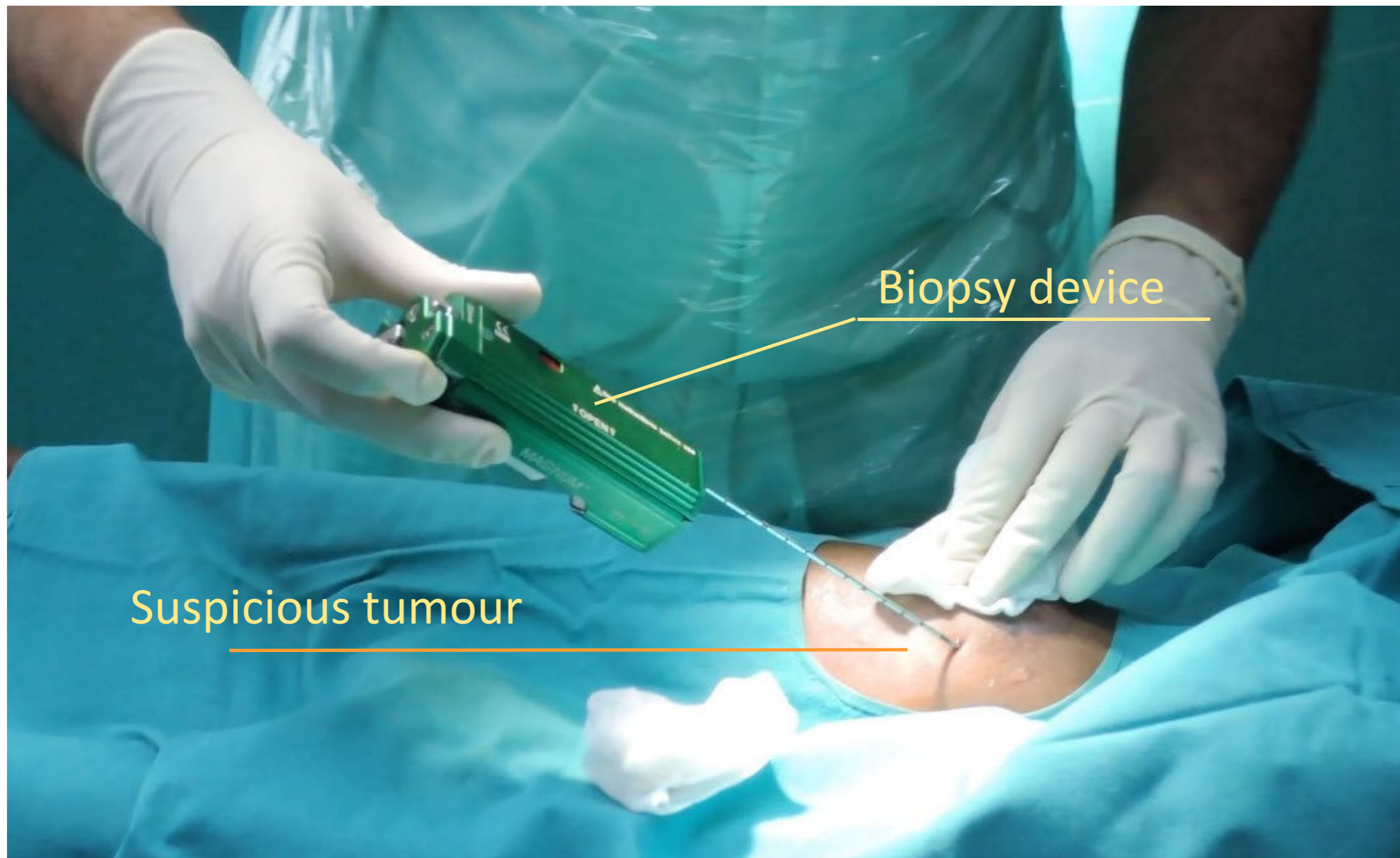

Biopsy - noun. an examination of tissue removed from a living body to discover the presence , cause or extent of a disease.

RESEARCH

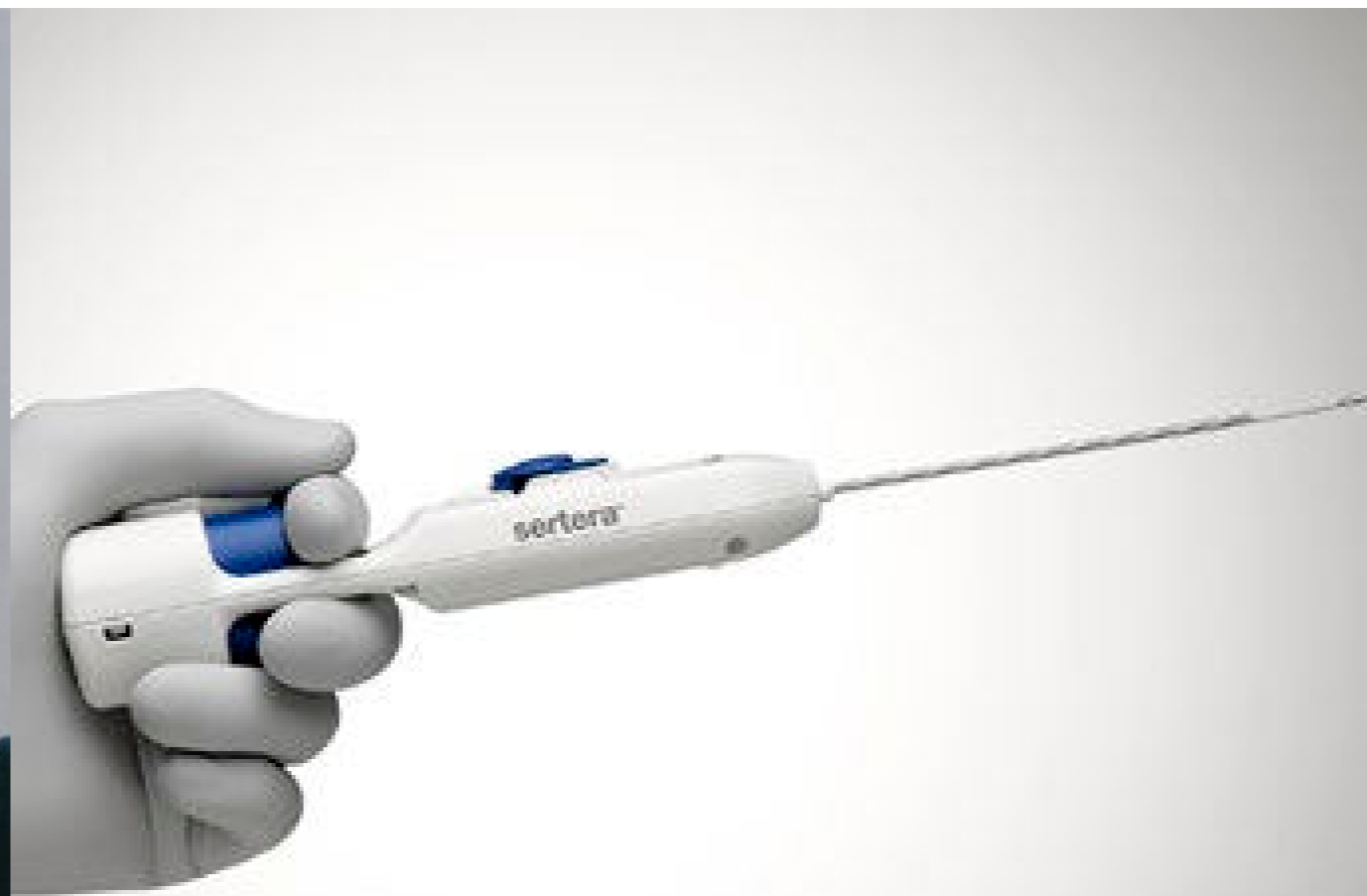

TYPES OF BIOPSIES

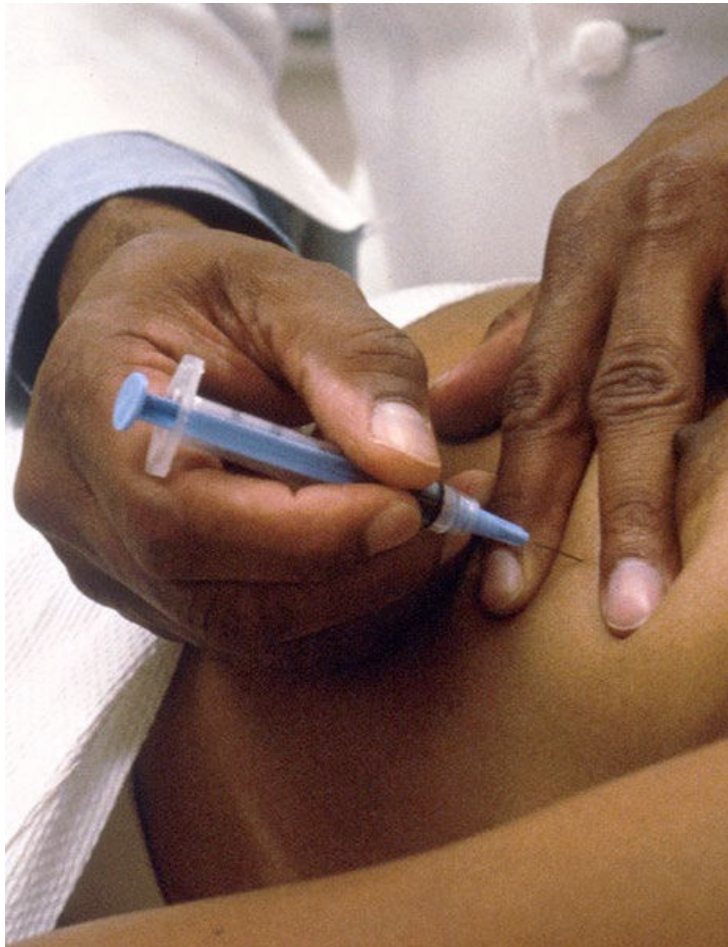

The doctor may use a fine needle attached to a syringe (see below) to remove a small amount of tissue from the suspicious area – called **fine needle aspiration**.



a **core needle biopsy** may be done which uses a fatter, hollow needle. As a result, this type of biopsy is somewhat more painful, area will be numbed before insertion of the needle.



Sometimes a **surgical biopsy** may be needed which can be done under either local or general anaesthetic, depending on where in the breast the lump actually is.

CORE NEEDLE

BIOPSY



- ▶ coaxial needle
- ▶ sequential firing
- ▶ throw speed 8 mts/sec

Principle of Trucut Biopsy

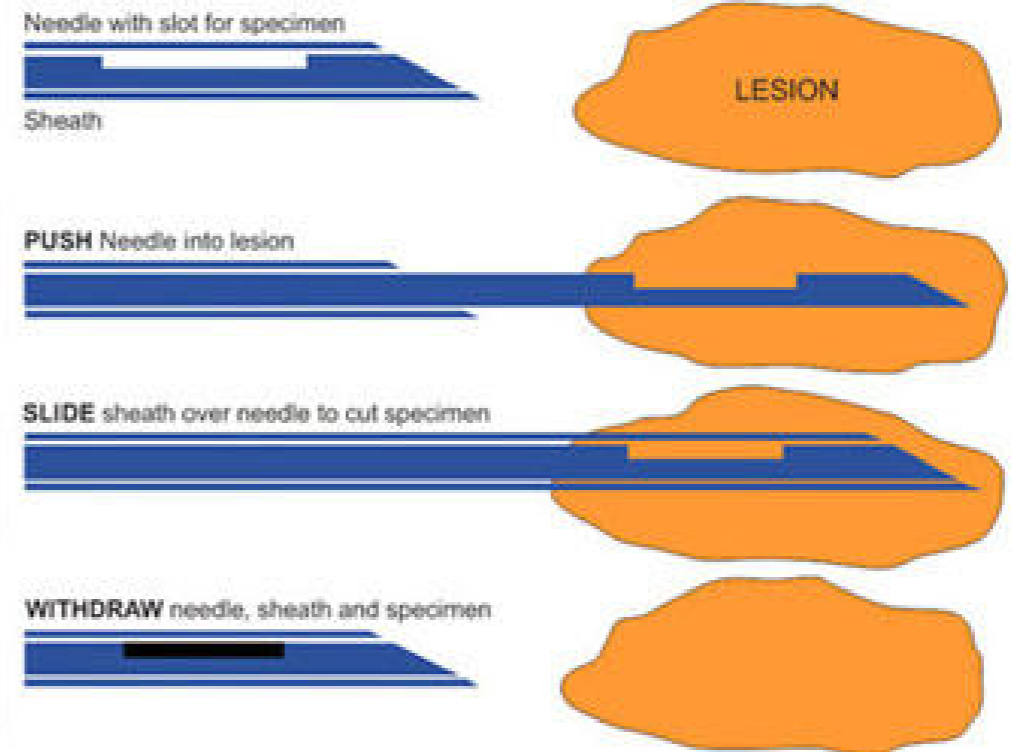

use and throw devices



reusable devices



FIELD VISIT

TATA CANCER
MEMORIAL CENTRE



ACTIVITY ANALYSIS

04:00 min



Cleaning the device

08:00 min

05:00 min



Cleaning biopsy spot with Betadine

18:00 min

06:00 min

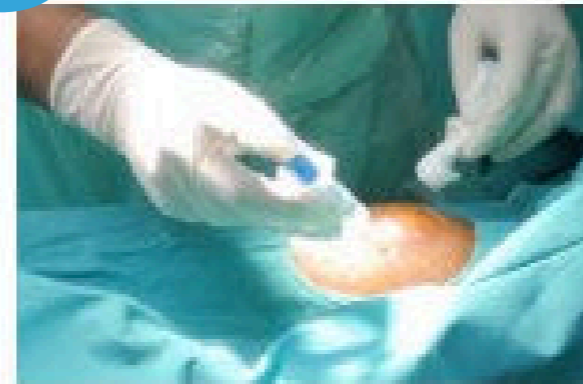

Giving Anaesthesia

19:00 min

07:00 min



Making a cut at Biopsy spot

25:00 min

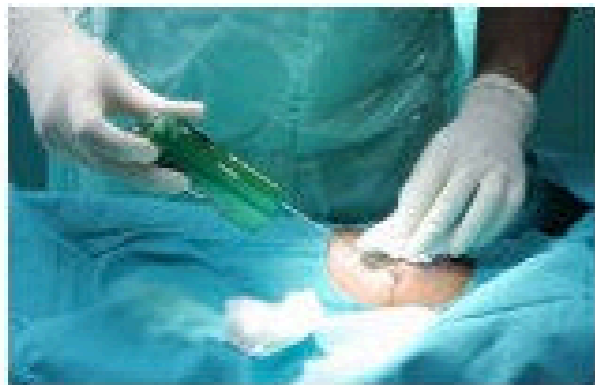

Biopsy



Removing the samples



Stitching the Biopsy spot



collecting the samples

PROBLEM IDENTIFIED

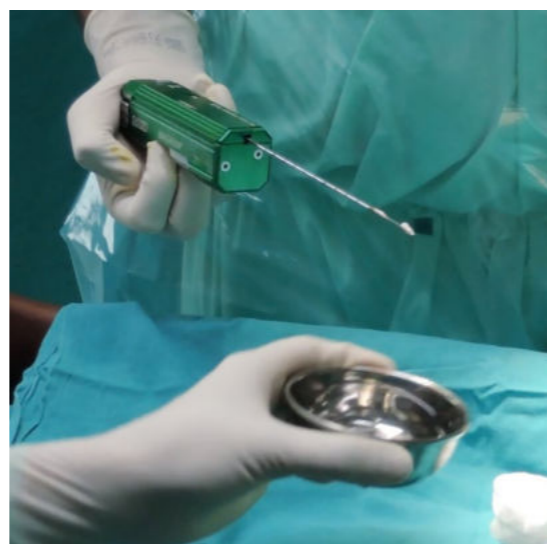
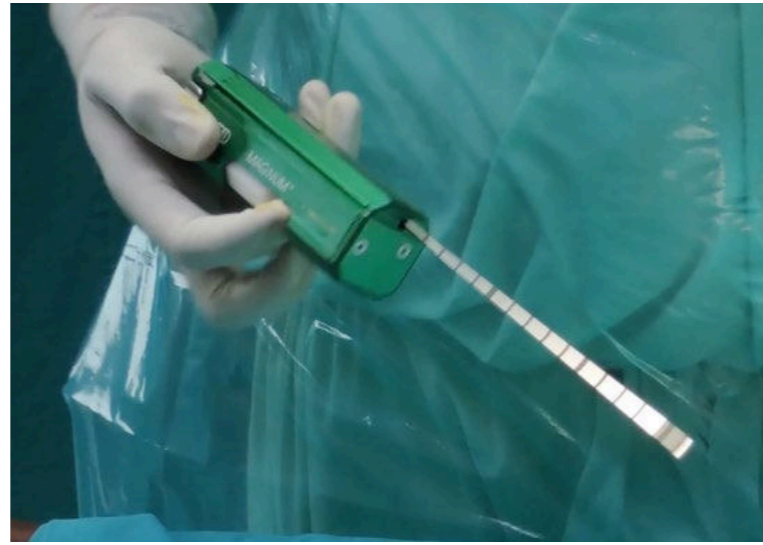



sample sticks to the needle



sample transferring

REFINED

DESIGNED BRIEF

1. Redesign a Surgeon friendly reusable biopsy handle, with following requirements

- Can be used with existing Bard co-axial needle
- Ergonomic and comfortable to do all the sub functions
- Minimum holding postures
- Uses Bolt and nut mechanism

2. Design a tissue collection system, the system should simplify the process of transferring the samples to the formalin bottle.

BOLT AND NUT MECHANISM

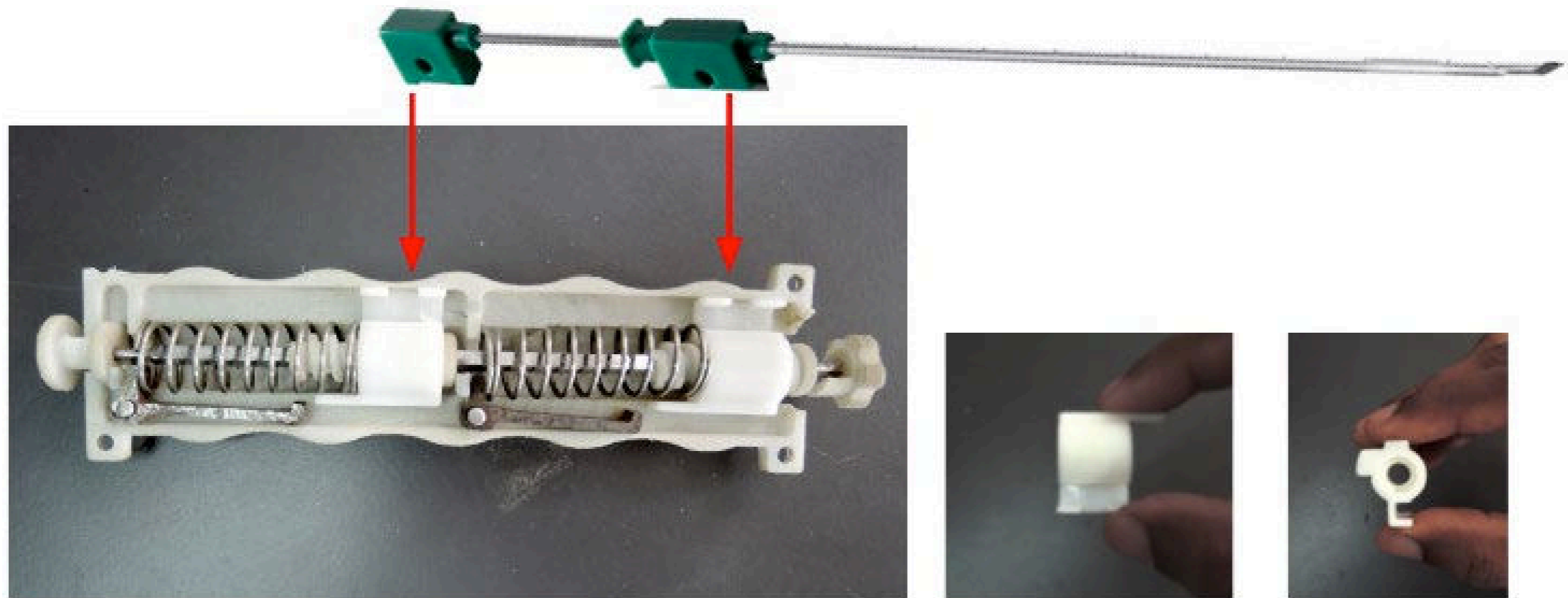

SUB FUNCTIONS OF REUSABLE BIOPSY HANDLE

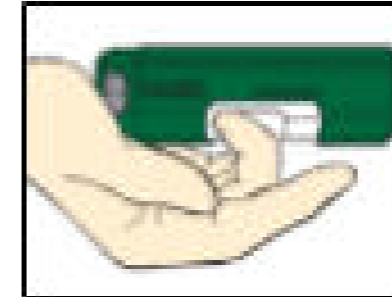
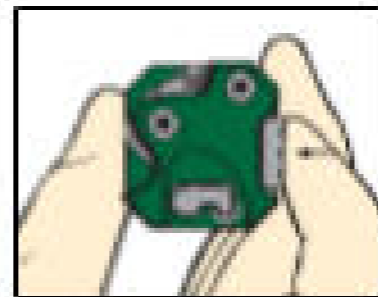
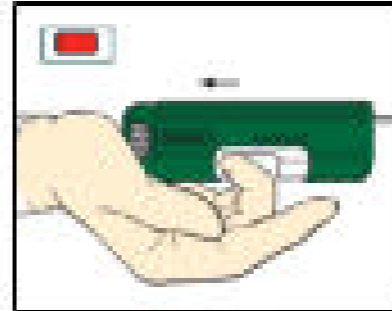
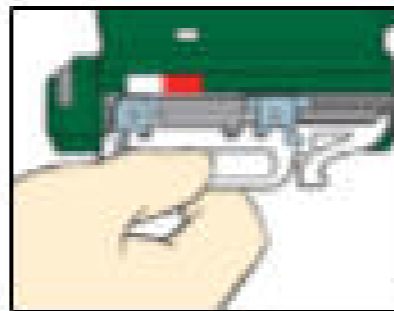
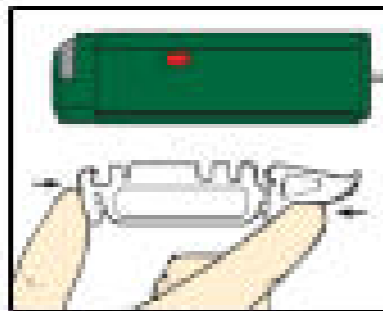

MOOD BOARD



soft
friendly
value

FORM IDEATION 1

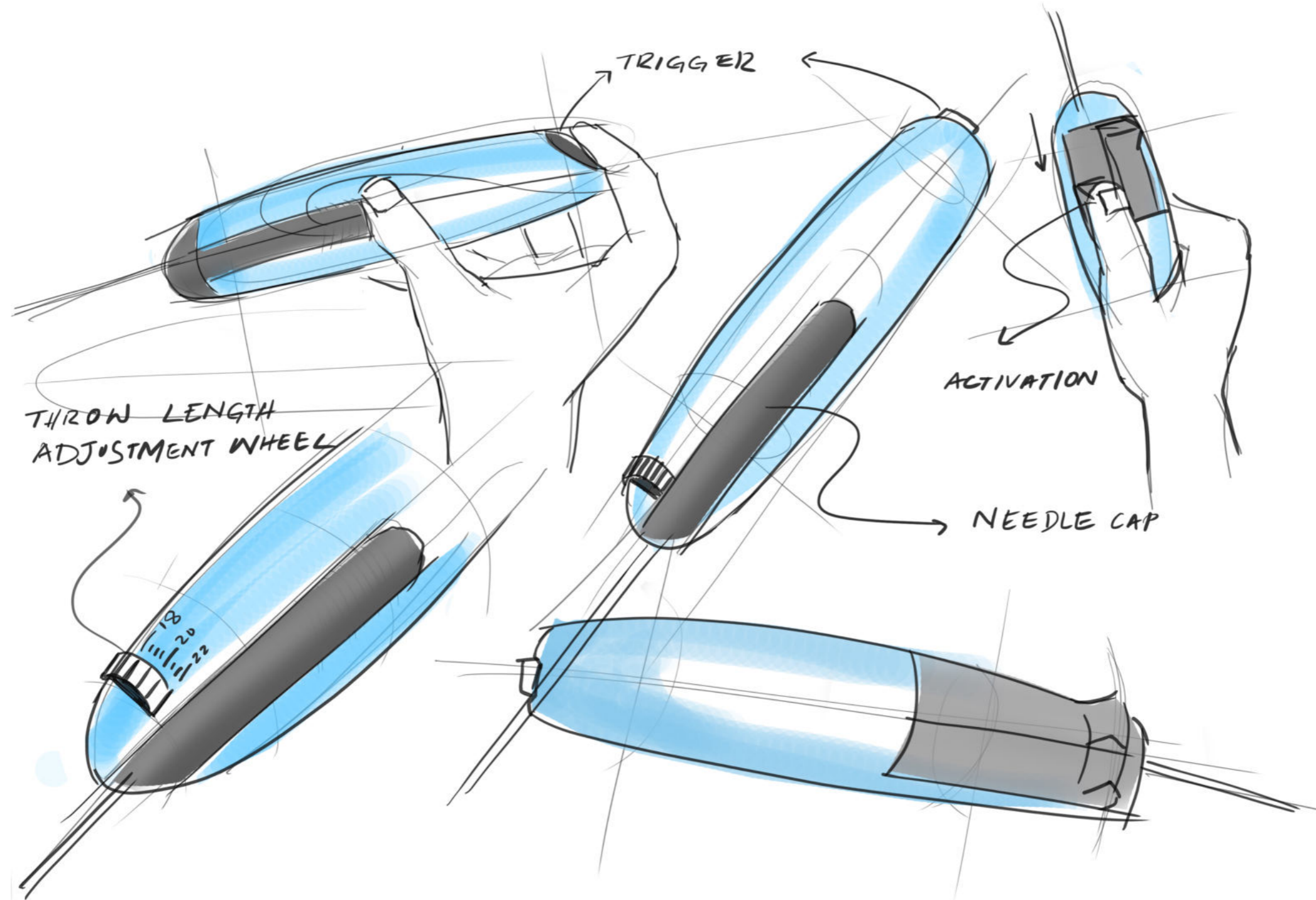

FORM IDEATION 2

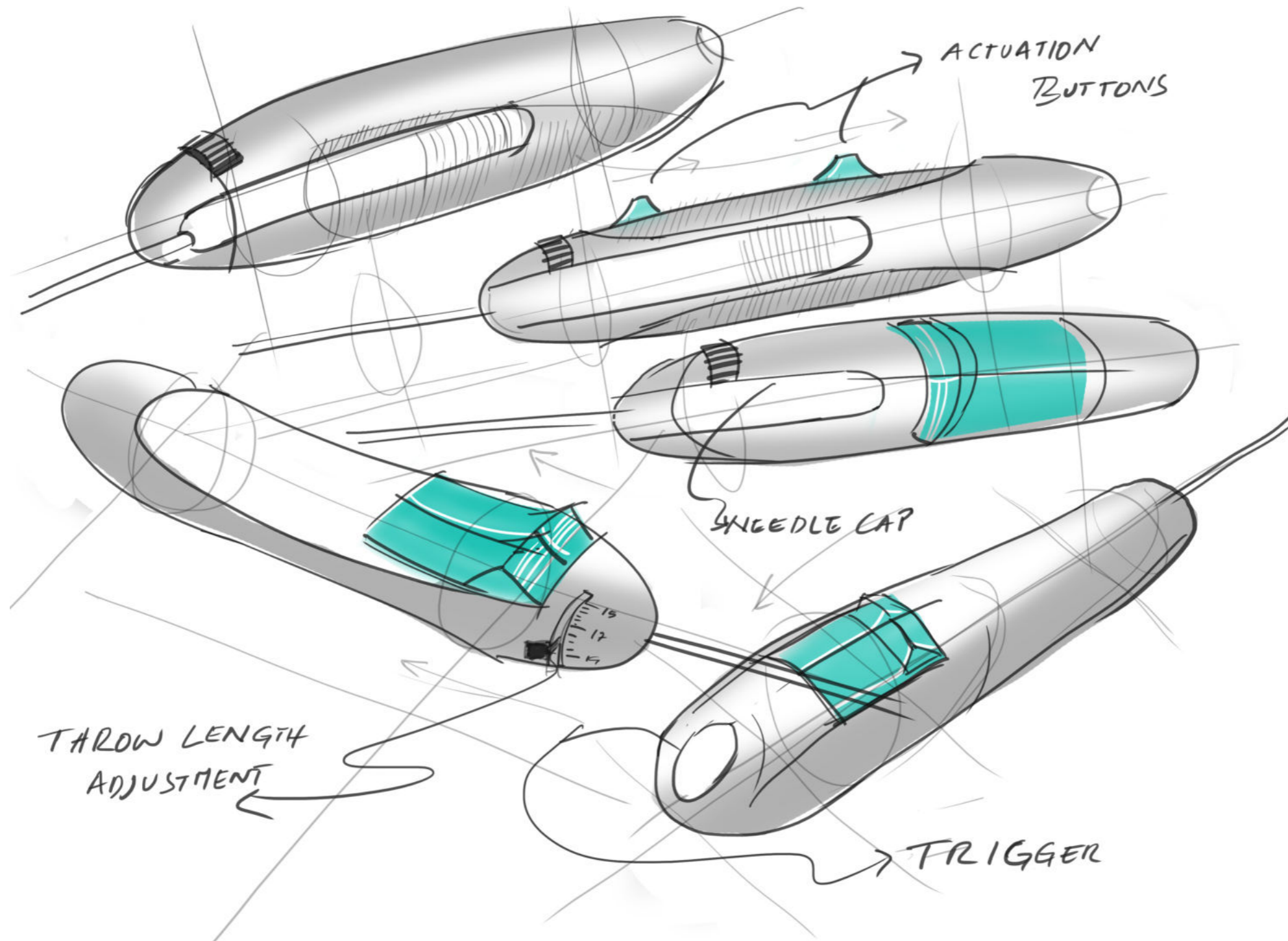

FROM IDEATION 2 SINGLE ACTUATION BUT

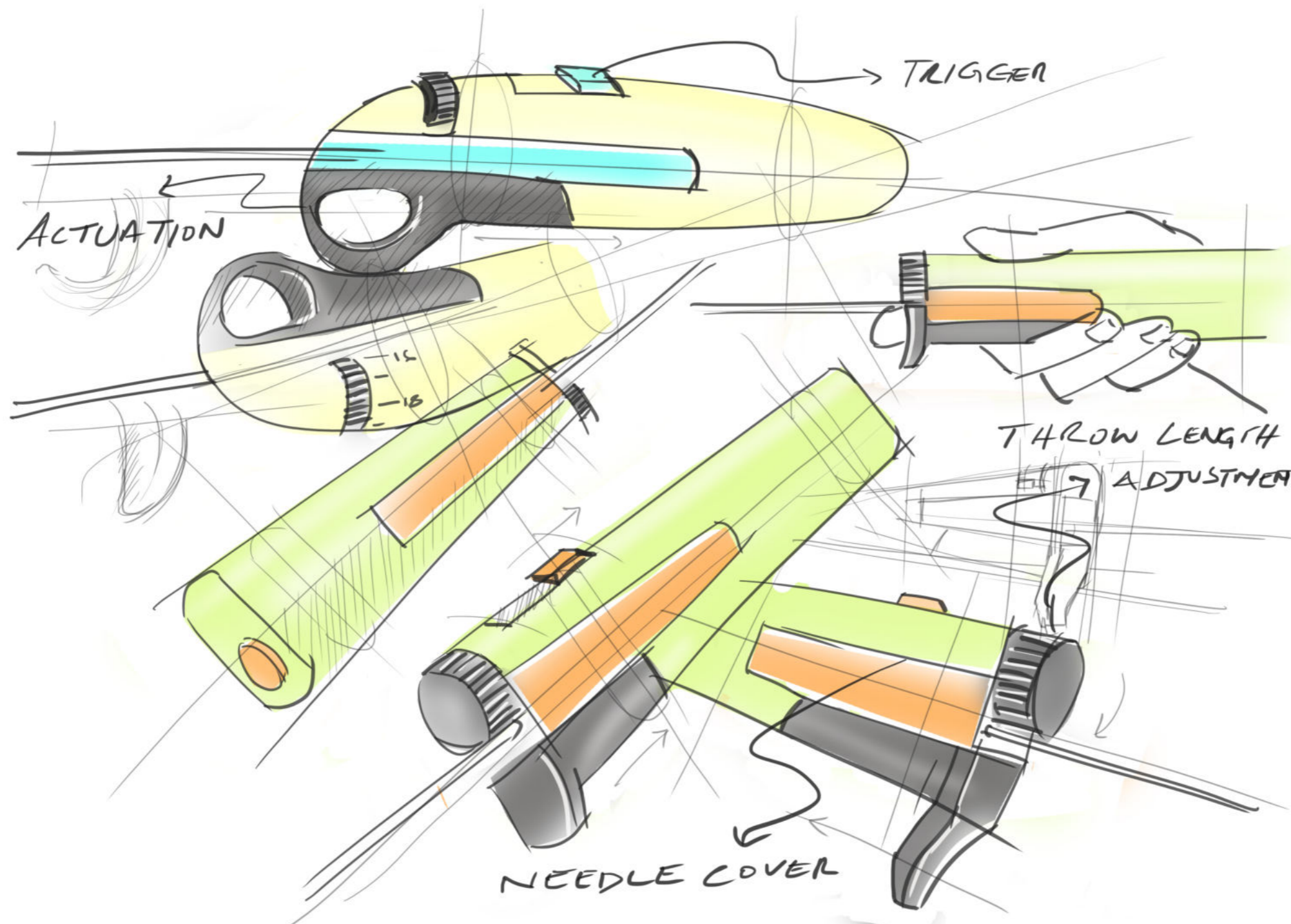

FROM IDEATION 2

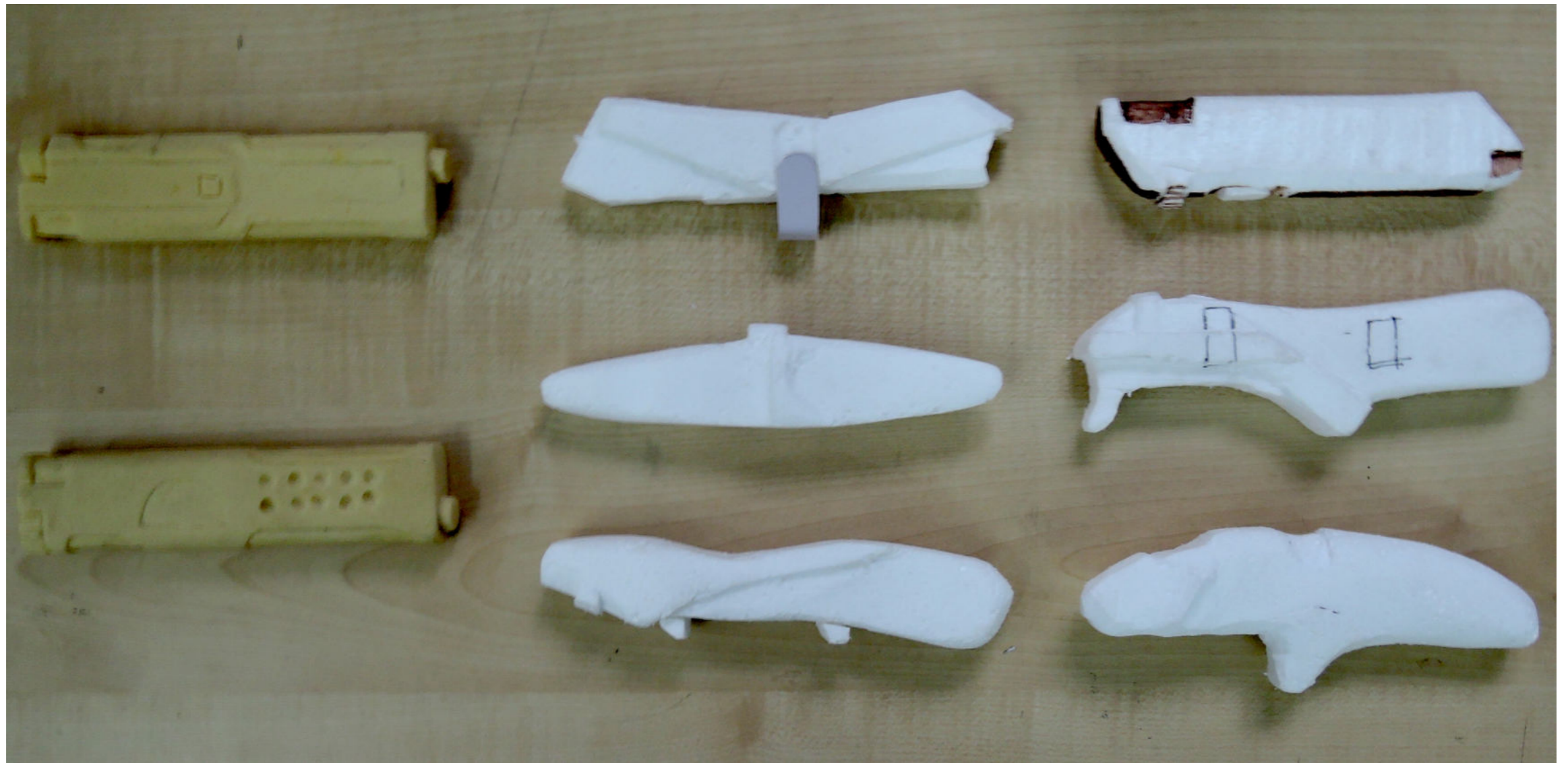

PROTOTYPE 1



FEEDBACK



Feed back on the new design is taken from Dr Manish Agarwal on the new forms. The feed is positive on the sleeker design as it is better ergonomic than the existing products. Further ideation is and form study is done to improve the design

FROM IDEATION 3 WITH GRIP

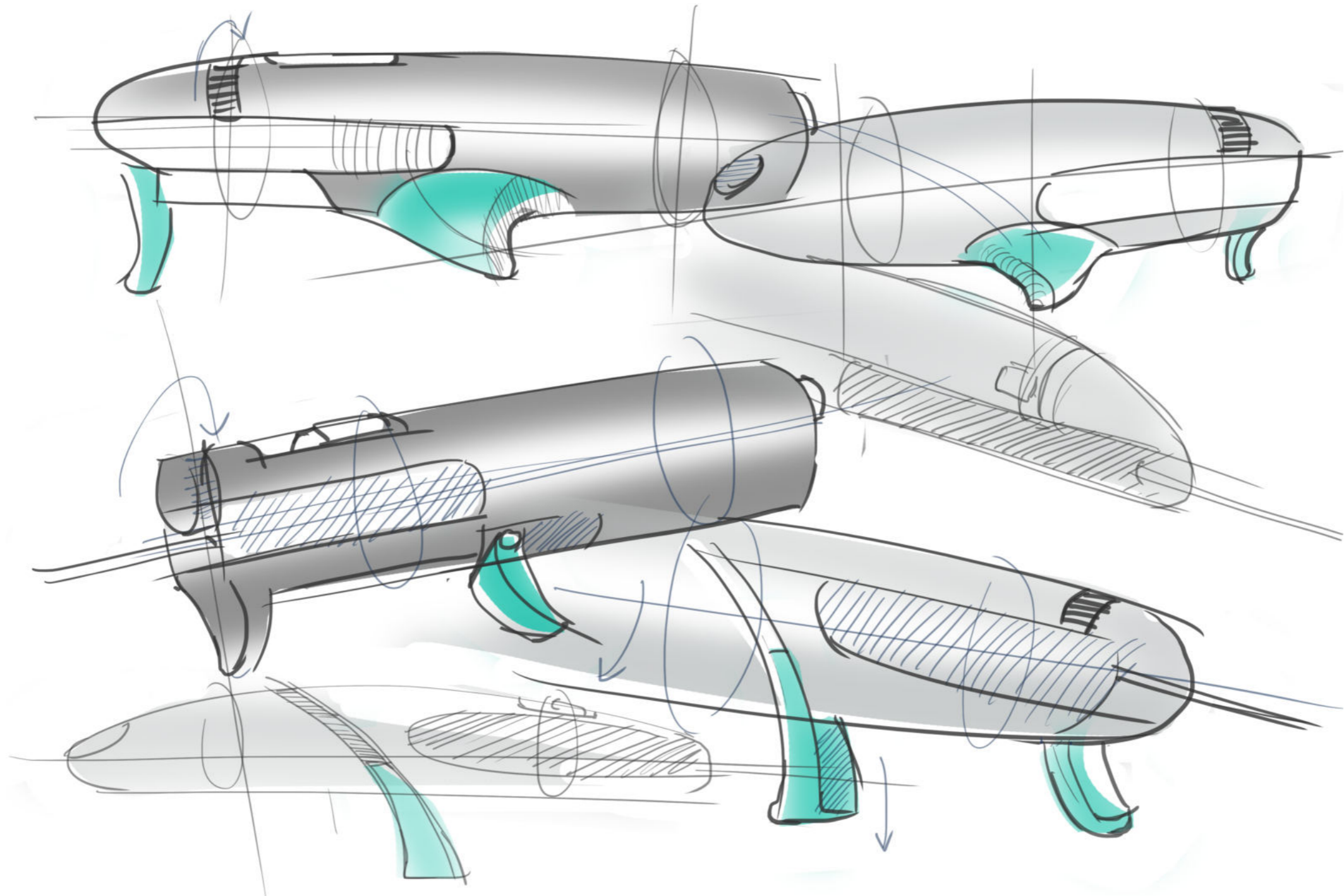

FROM IDEATION 3

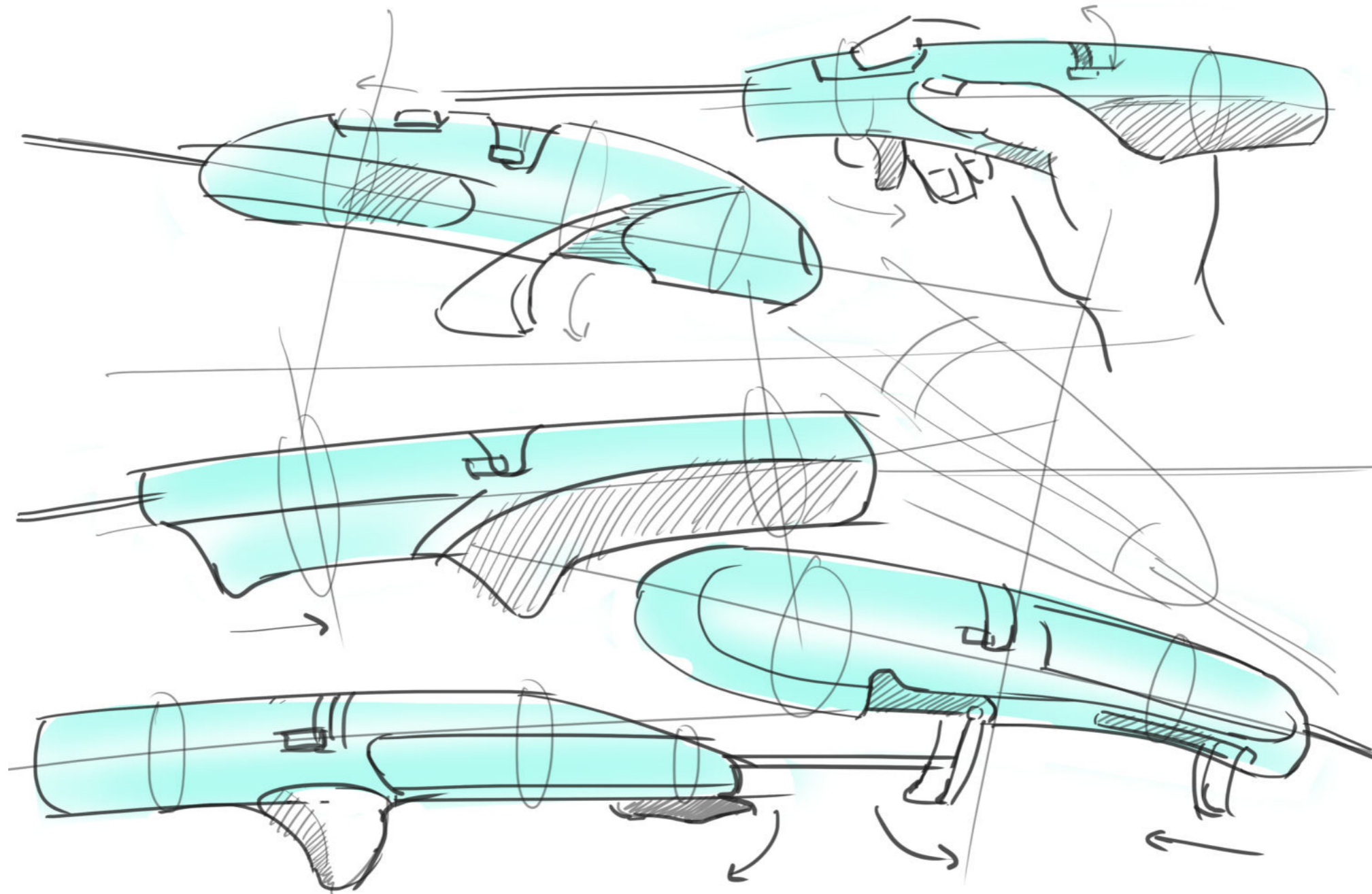

FROM IDEATION 3

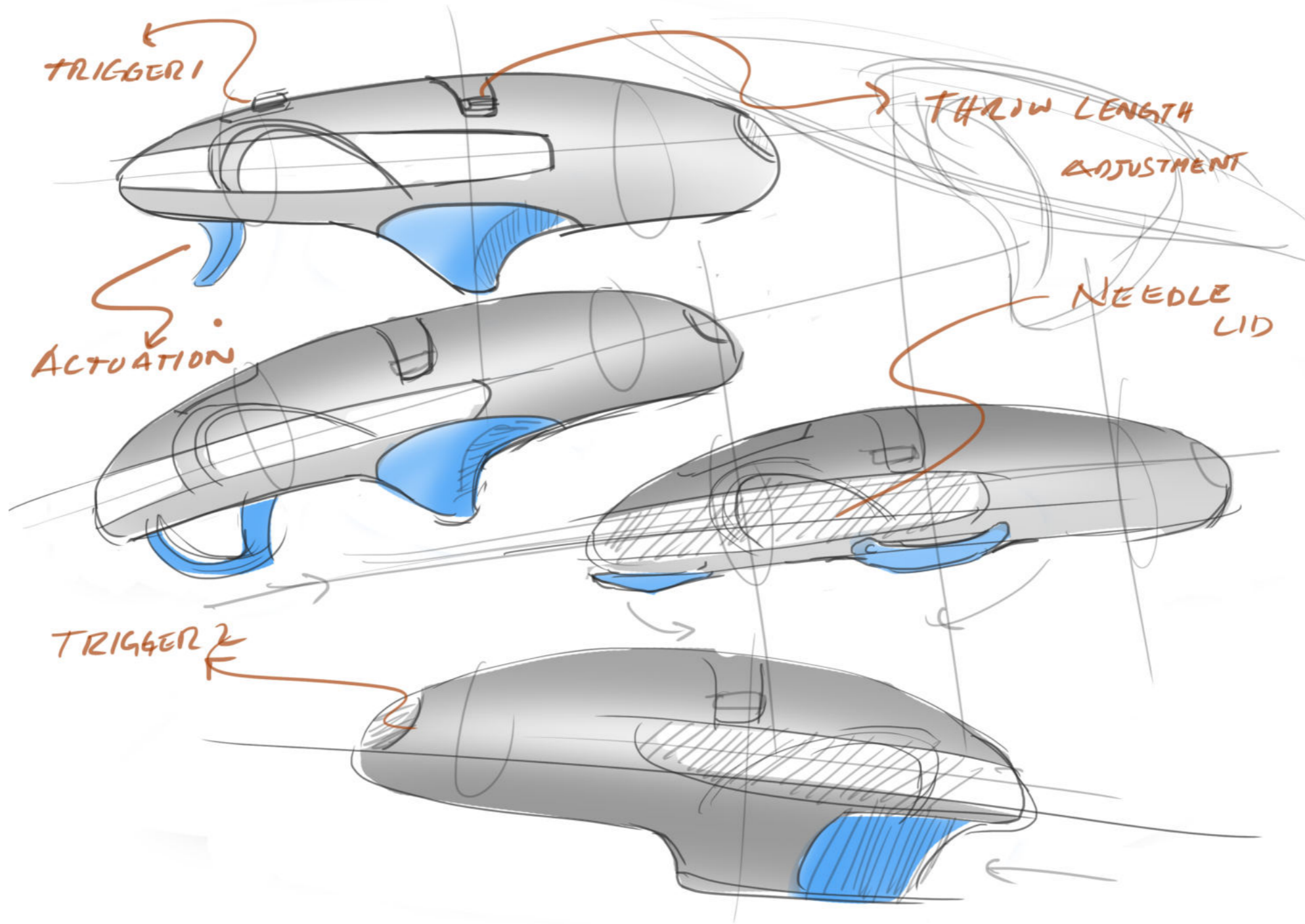

FROM IDEATION 3

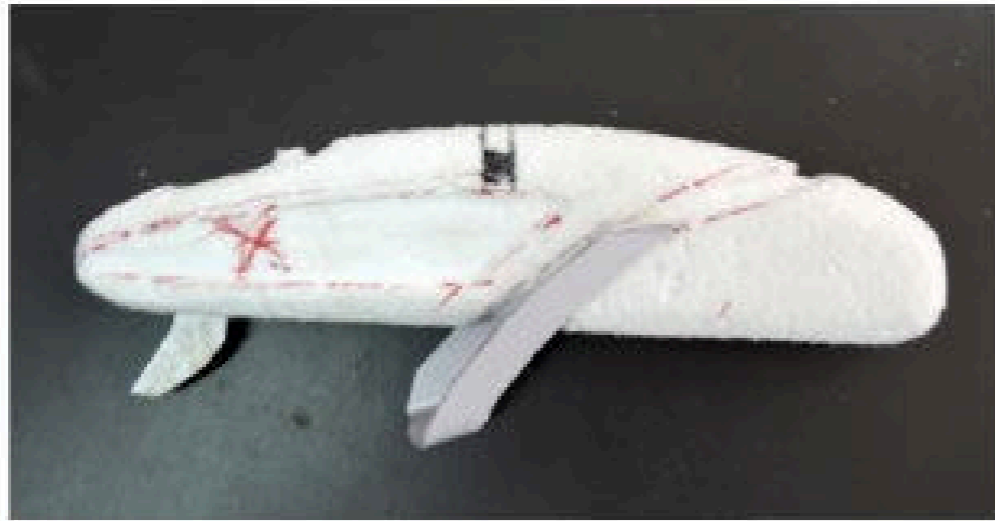

FROM IDEATION 3

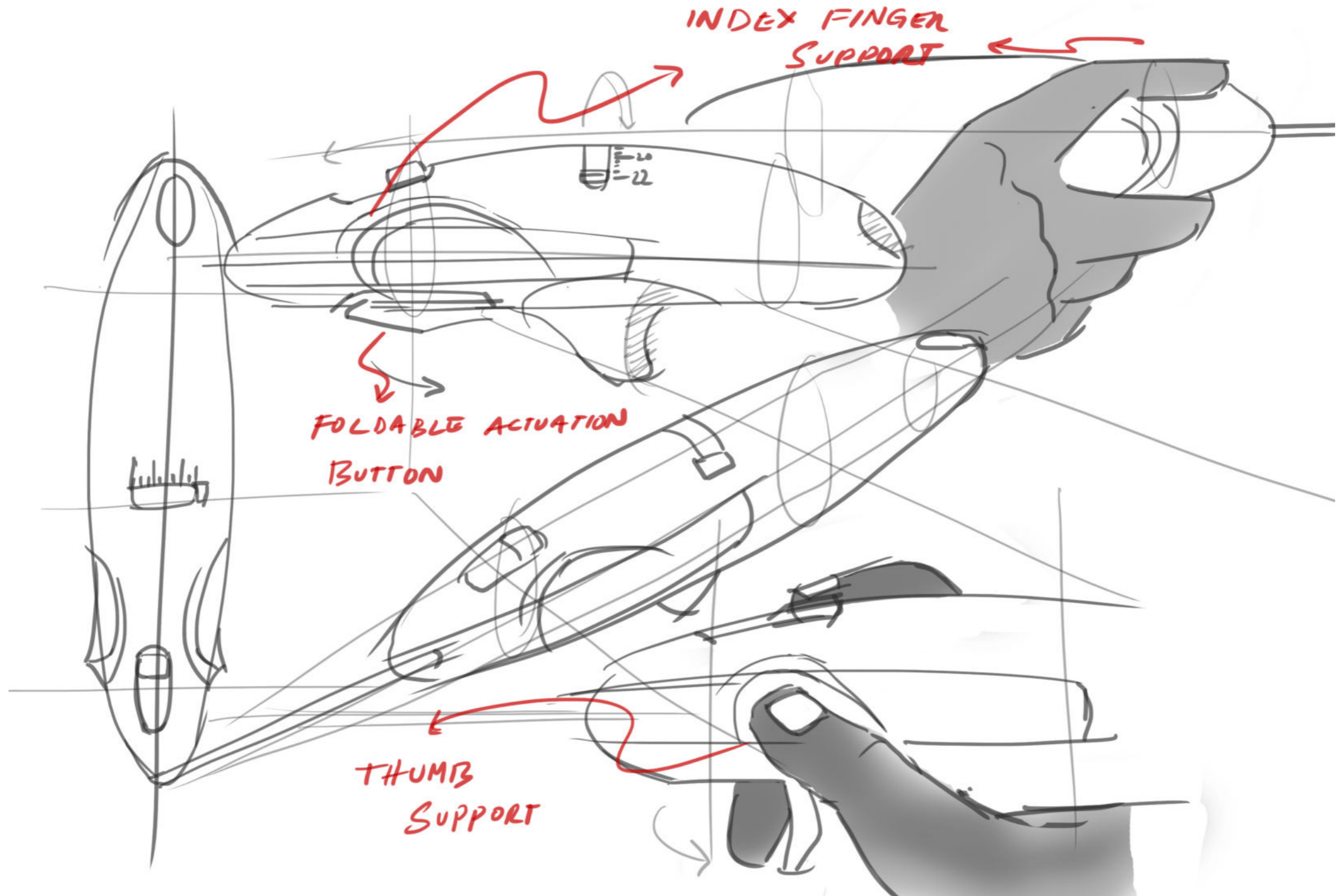

PROTOTYPE 2

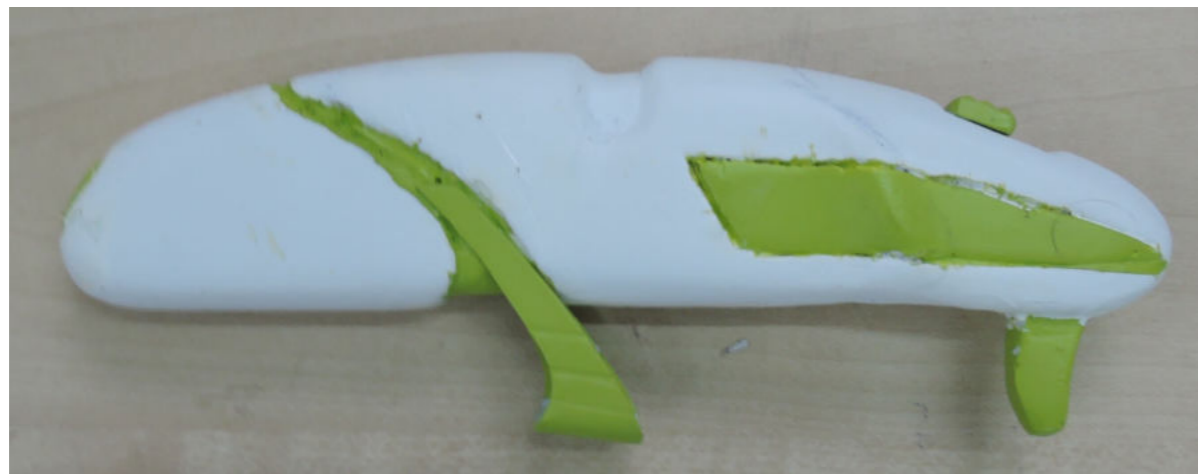

FROM IDEATION 4

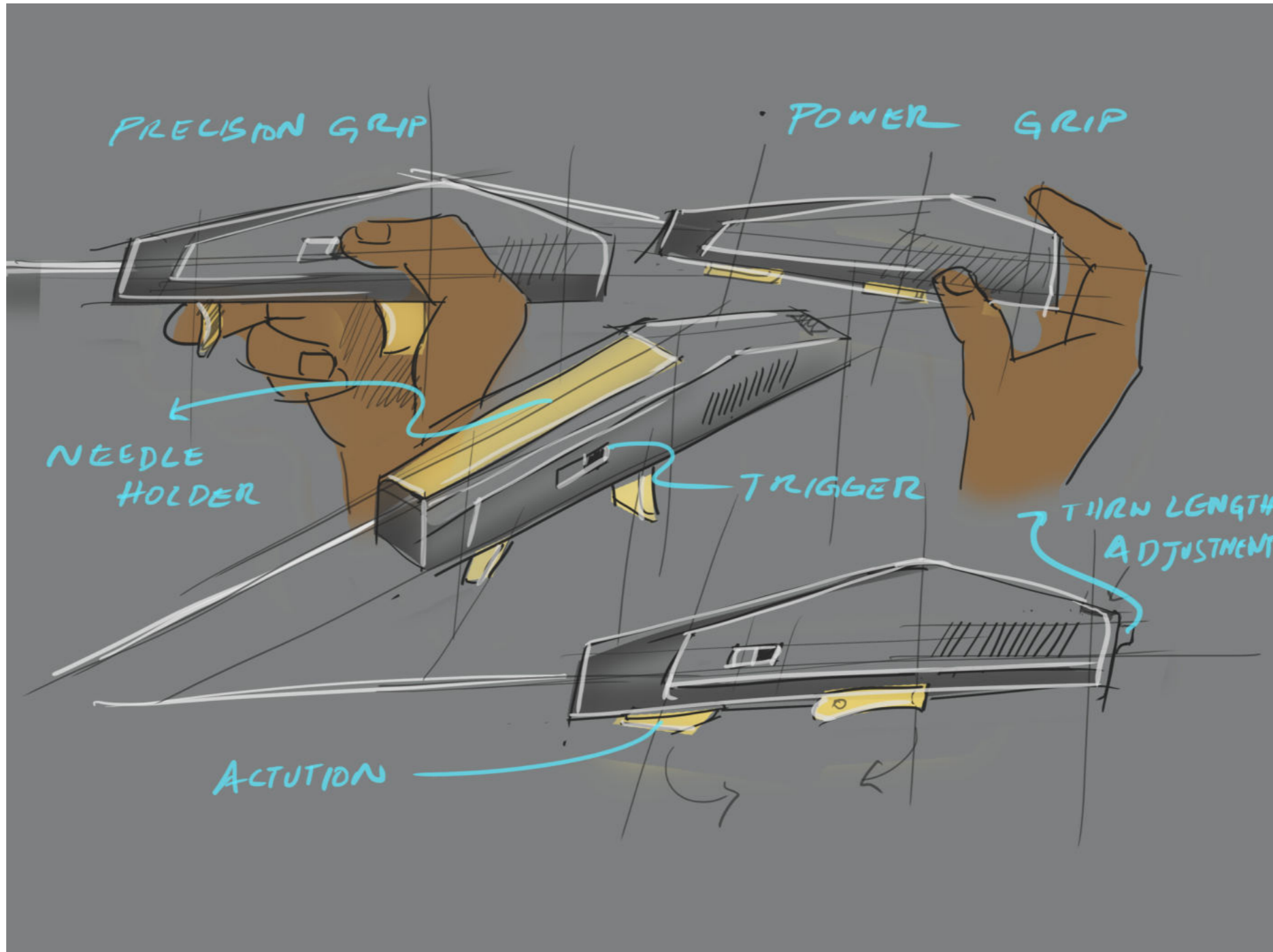

FROM IDEATION 4

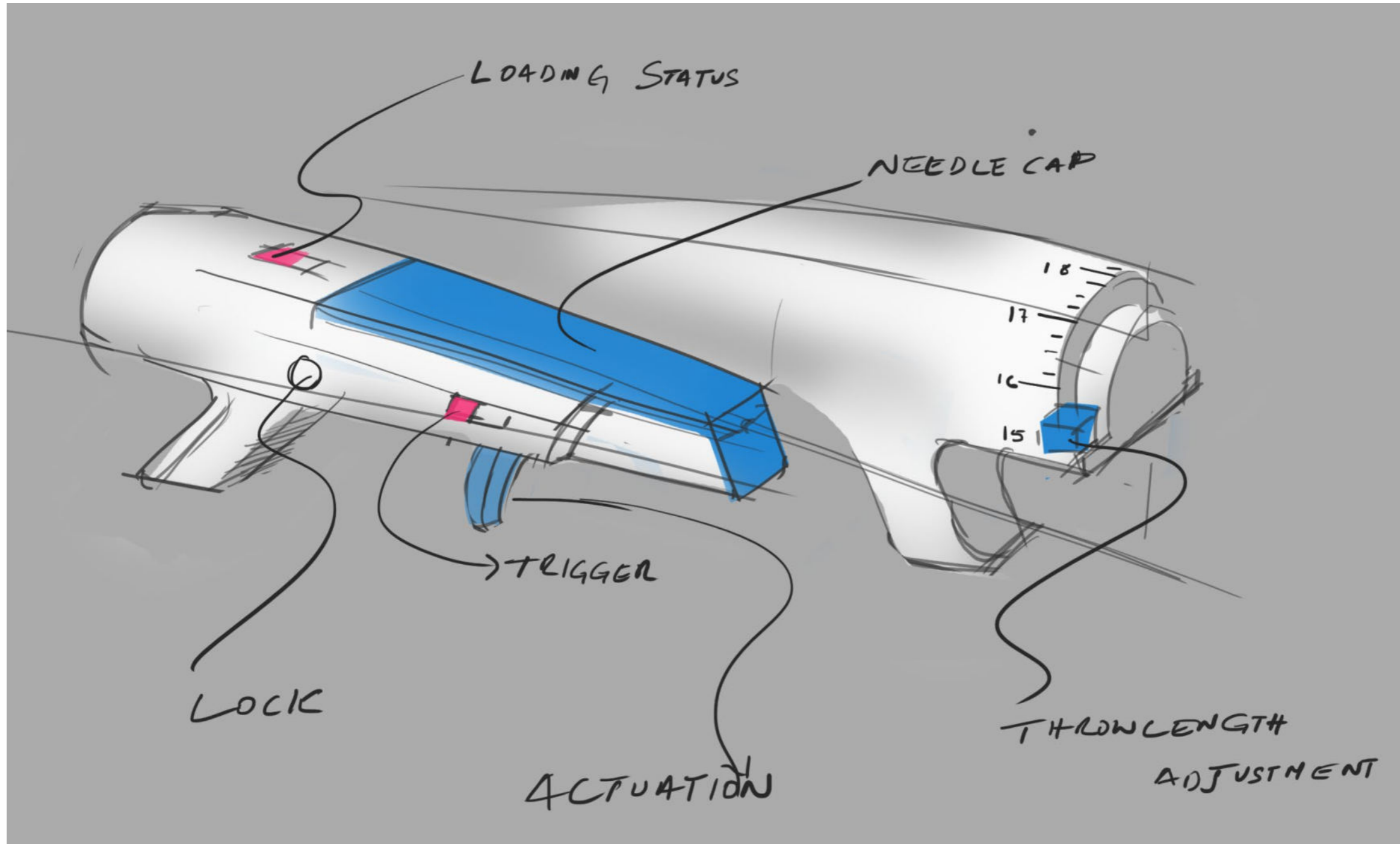

FROM IDEATION 4



FINAL DESIGN

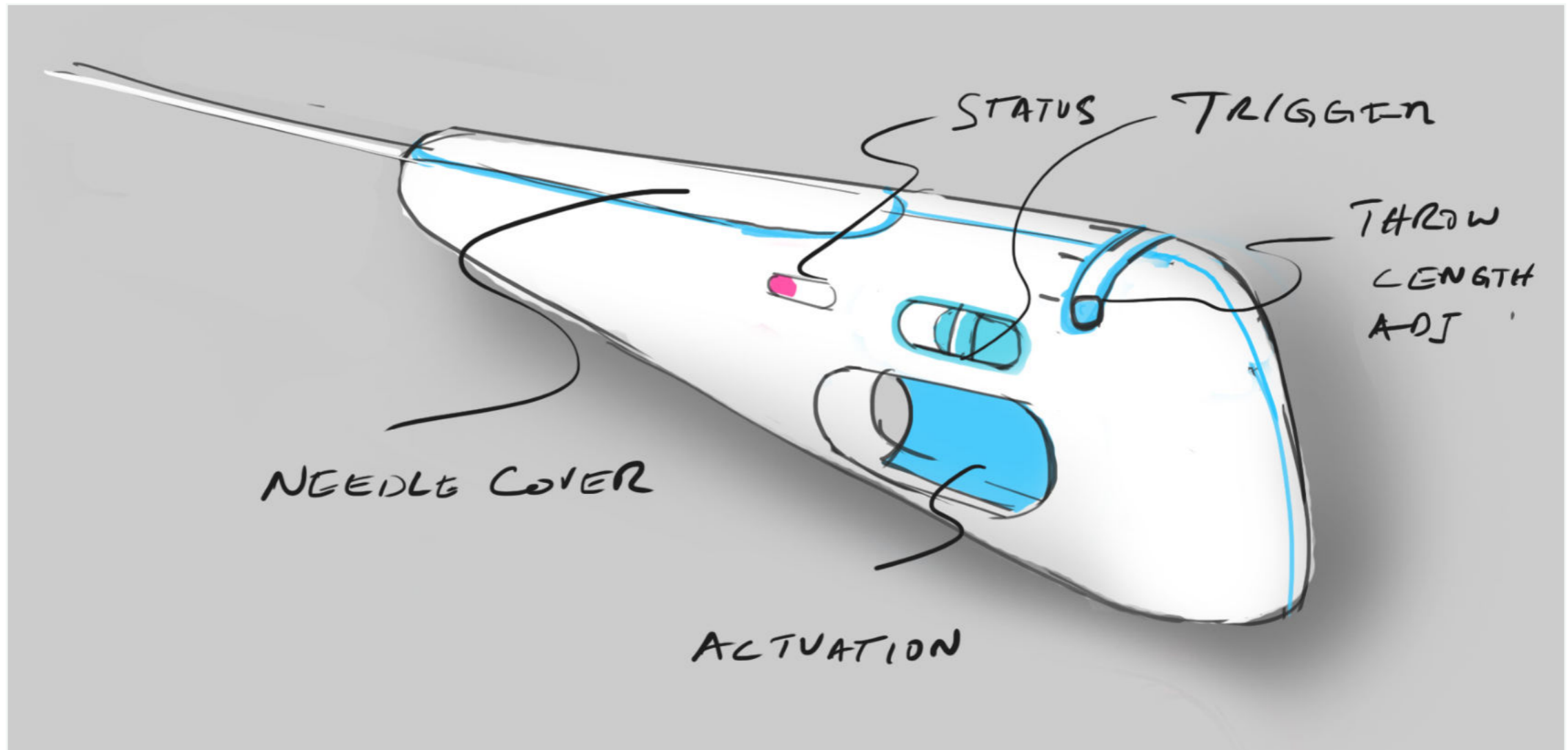

FINAL DESIGN

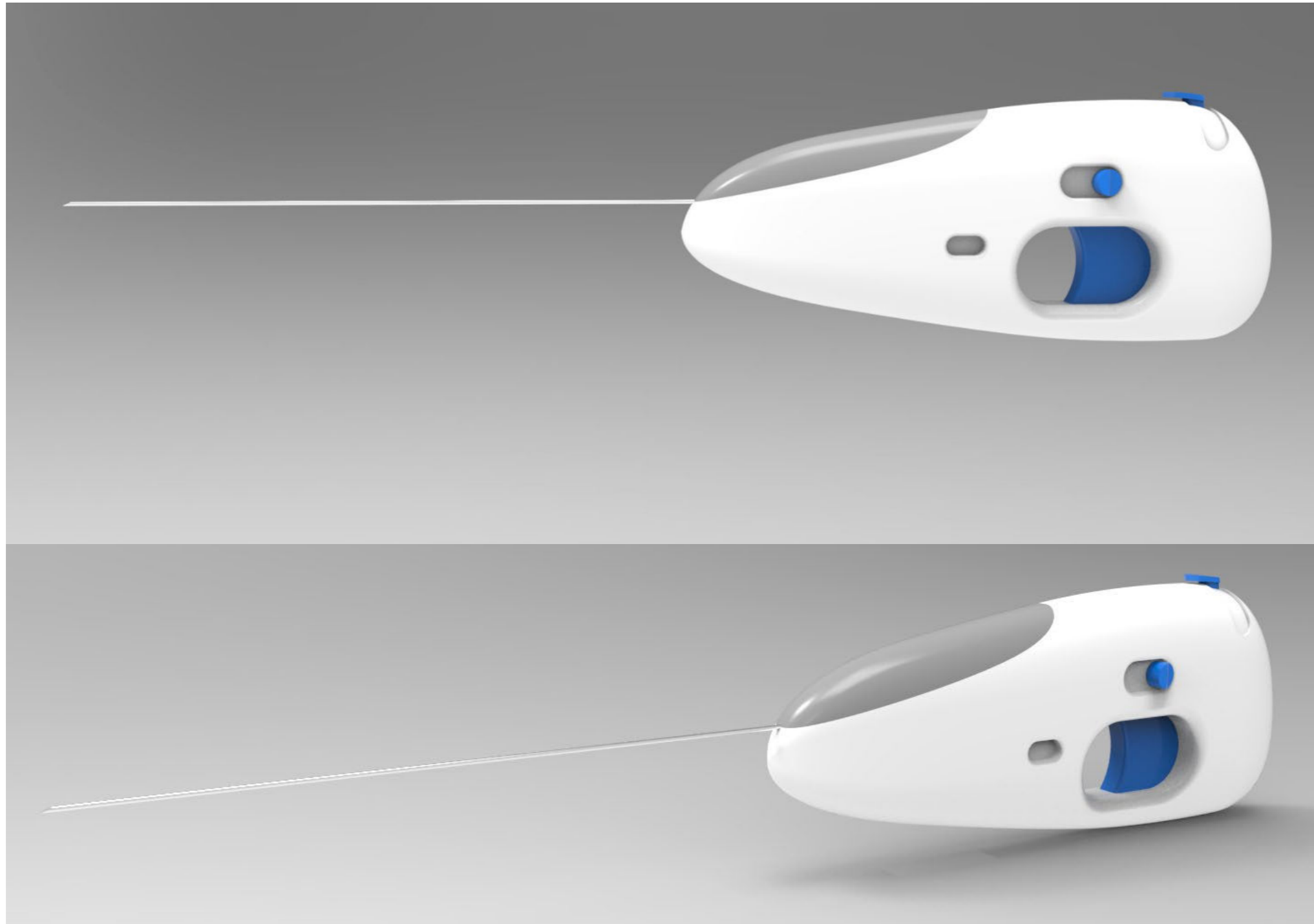

FINAL DESIGN

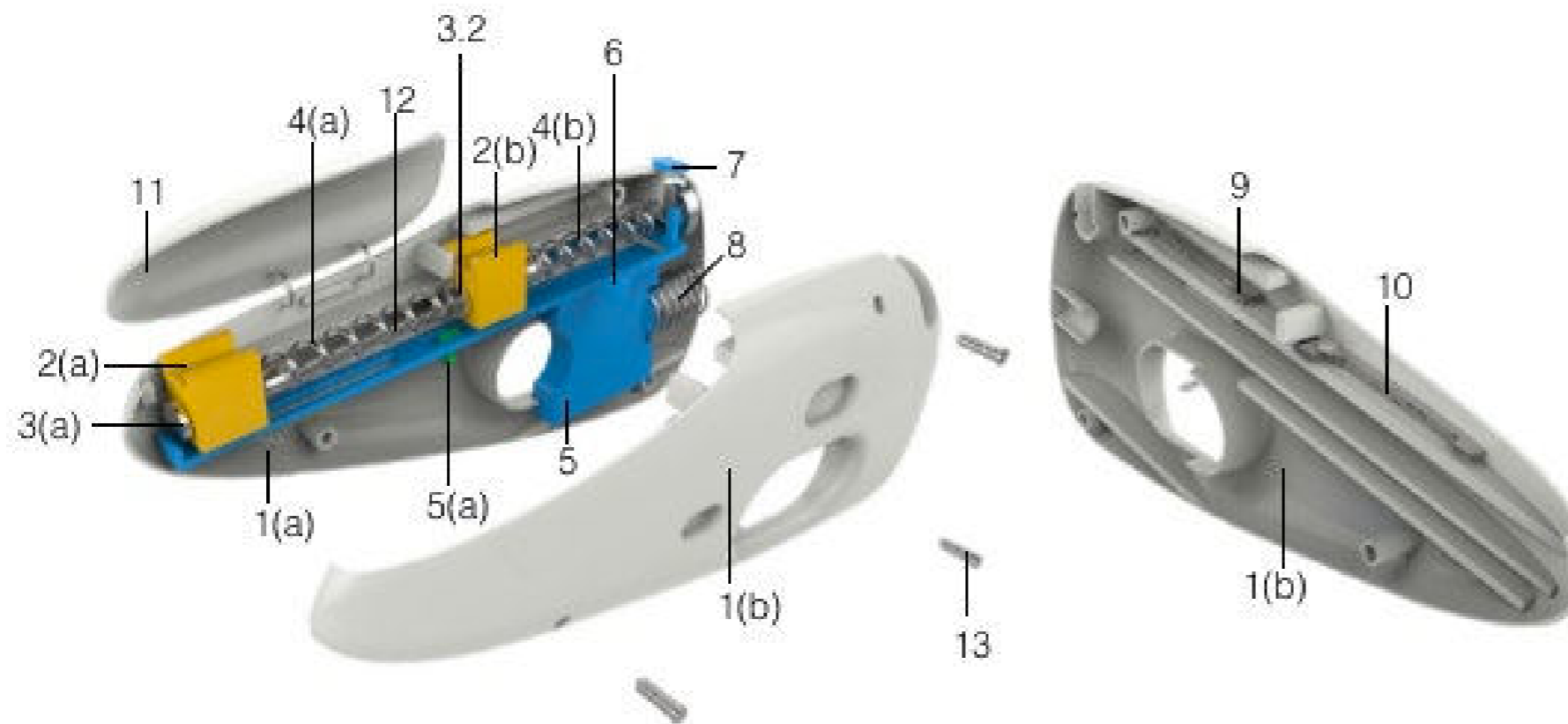

Parts

- 1(a) Outer case 1
- 1(b) Outer case 2
- 2(a) Outer needle holder
- 2(b) Inner needle holder
- 3(a) Outer needle bolt
- 3(b) Inner needle bolt
- 4(a) Outer needle spring
- 4(b) Inner needle spring
- 5 Actuation button
- 5(a) Lever
- 6 Trigger
- 7 Throw adjustment button
- 8 Trigger spring
- 9 Inner needle L lever lock
- 10 Outer needle L lever lock
- 11 Needle cap
- 12 Rod to rotate the bolts
- 13 Screws

FINAL DESIGN PROTOTYPE



FINAL DESIGN PROTOTYPE

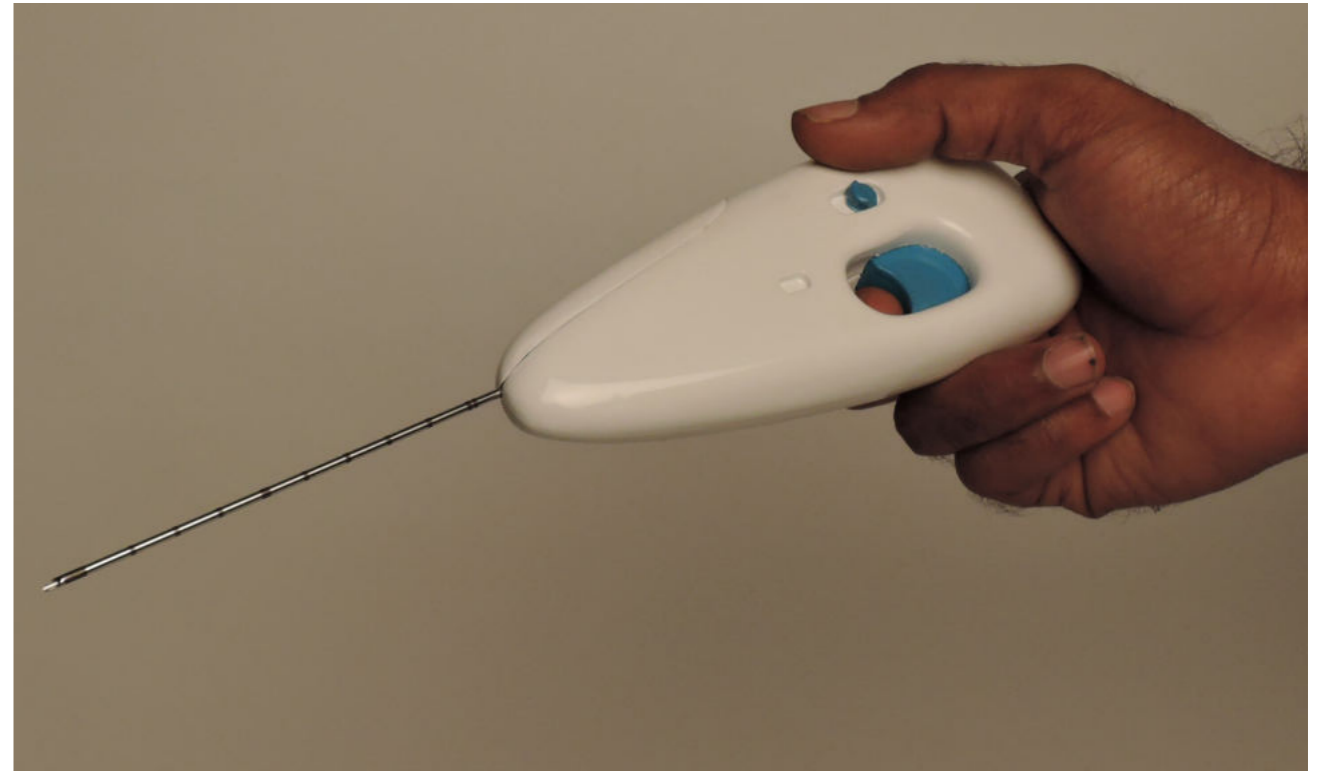
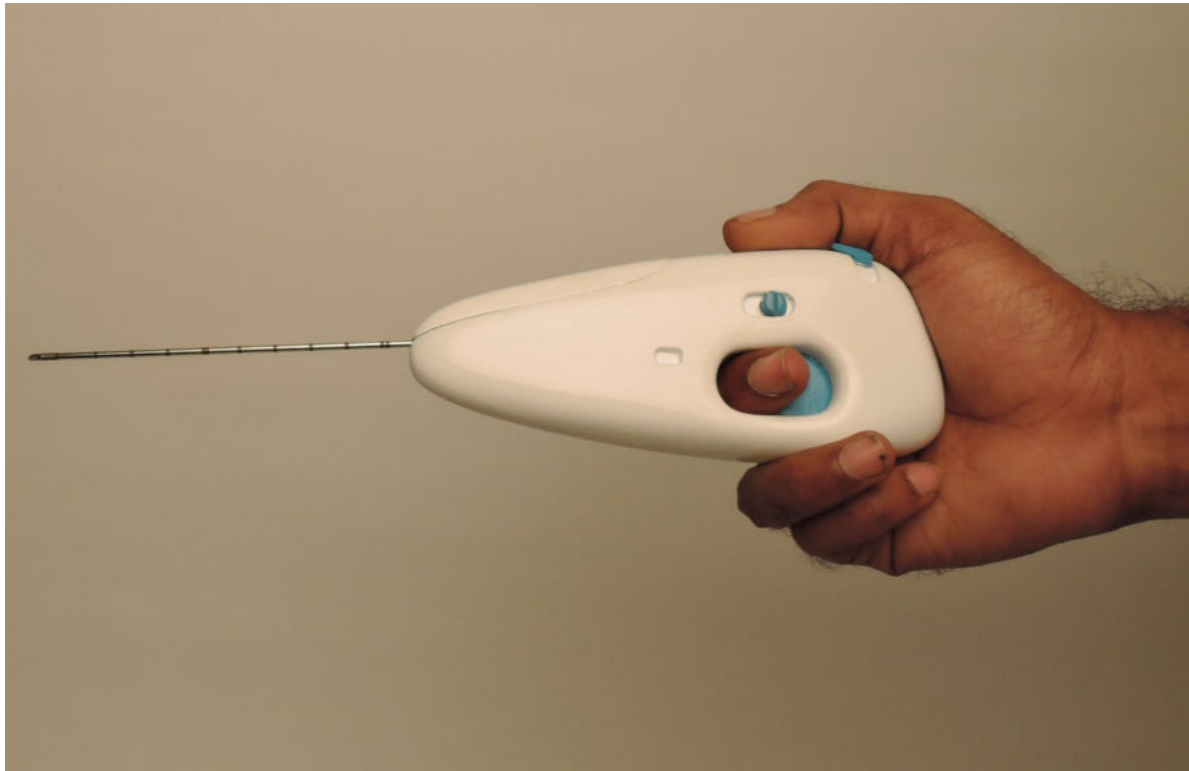

TISSUE COLLECTION DEVICE



TISSUE COLLECTION DEVICE



TISSUE TRANSFERRING



TROLLY DESIGN IDEATION



TROLLY DESIGN IDEATION

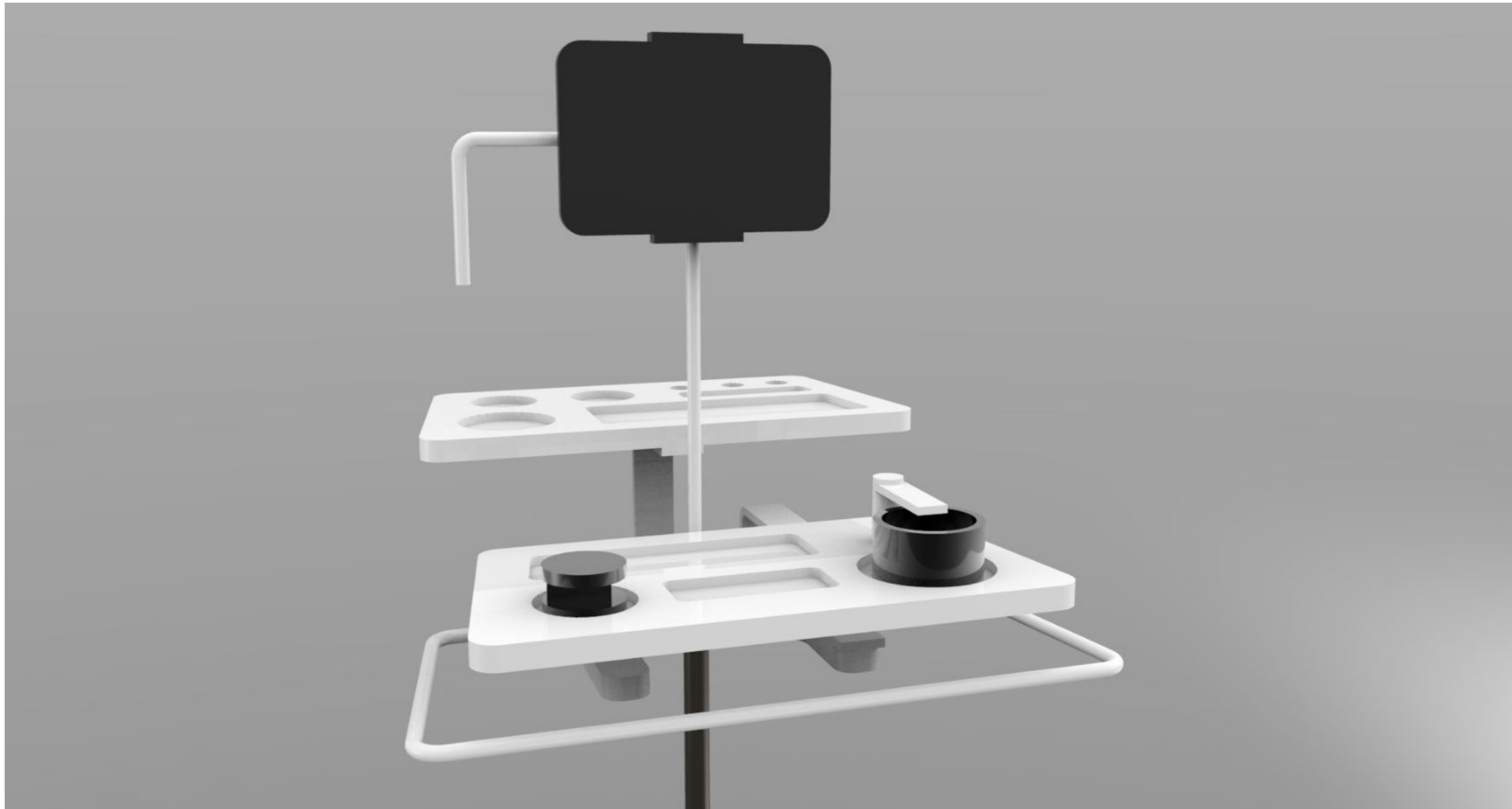

FEEDBACK

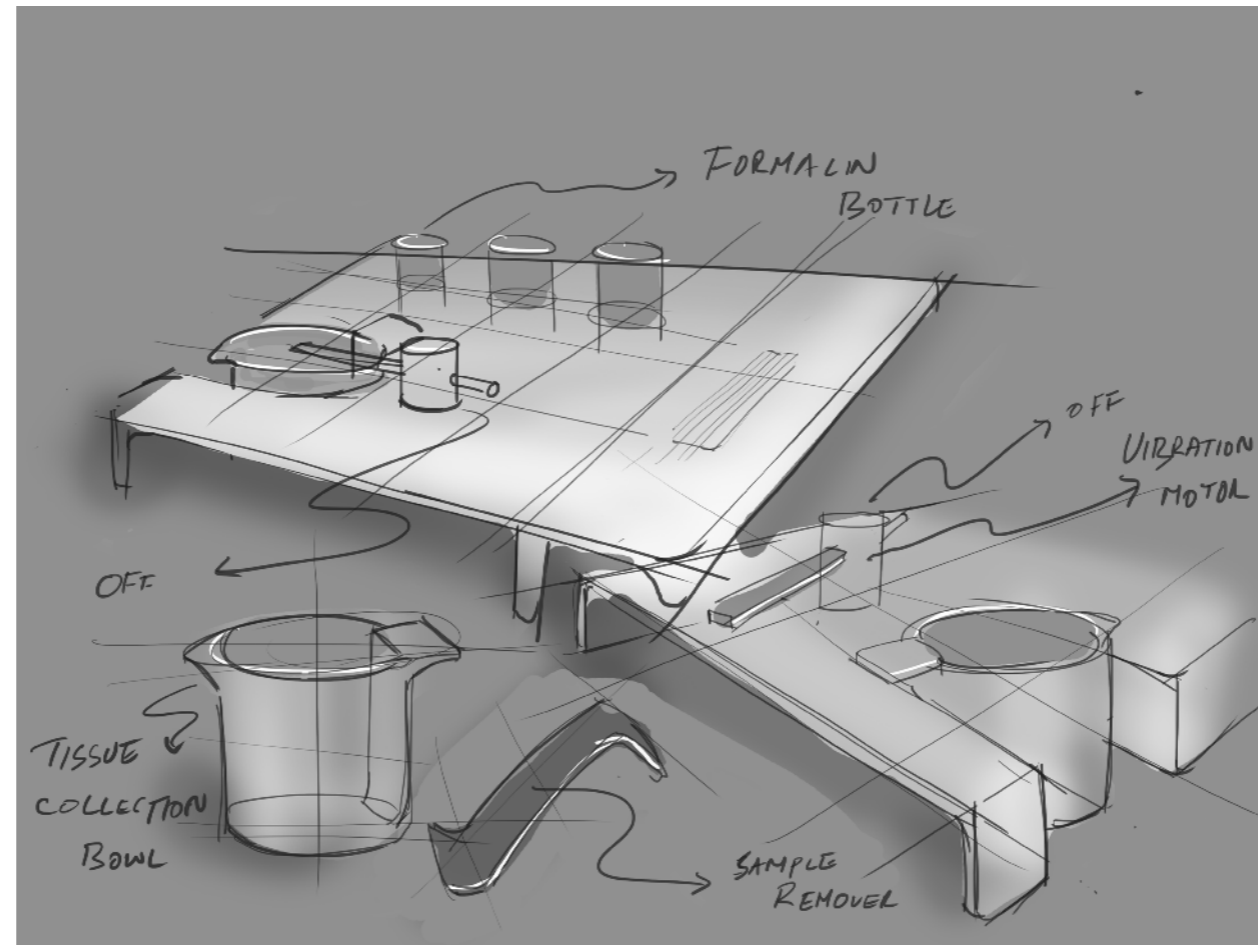

After feedback it is decided to design a minimalistic tissue collection bowl so that it can be used in all scenarios

FINAL DESIGN

Metal plate with perforations
to collect tissue

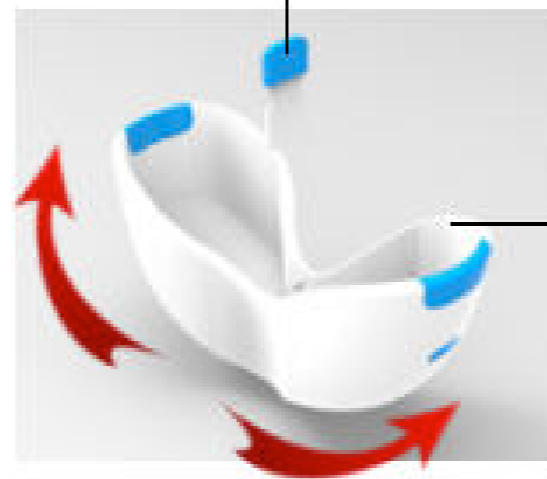

vibration Area

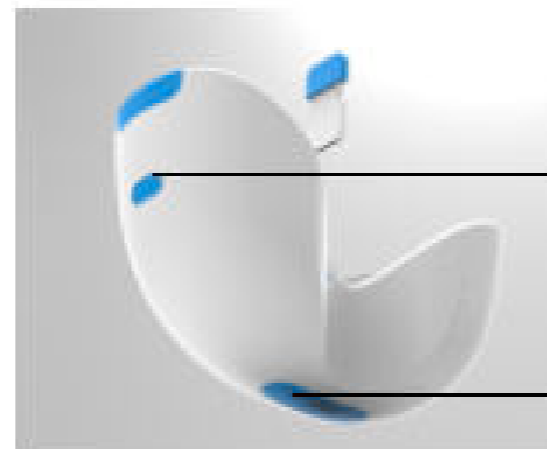

charging port

vibration actuation button

FINAL DESIGN

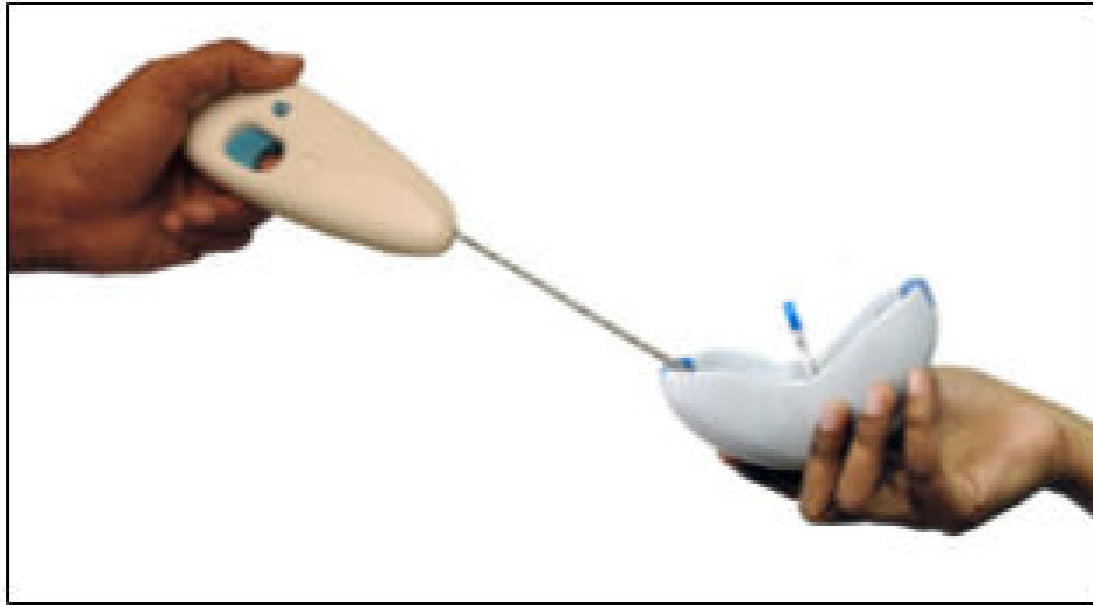

1. When needle touches the vibrating portion of the bowl, tissue gets separated and falls in the bowl.



2. When the water moves from one side the other, the tissue gets collected on the middle removable part.



3. Remove the middle part to collect the sample.

FINAL DESIGN

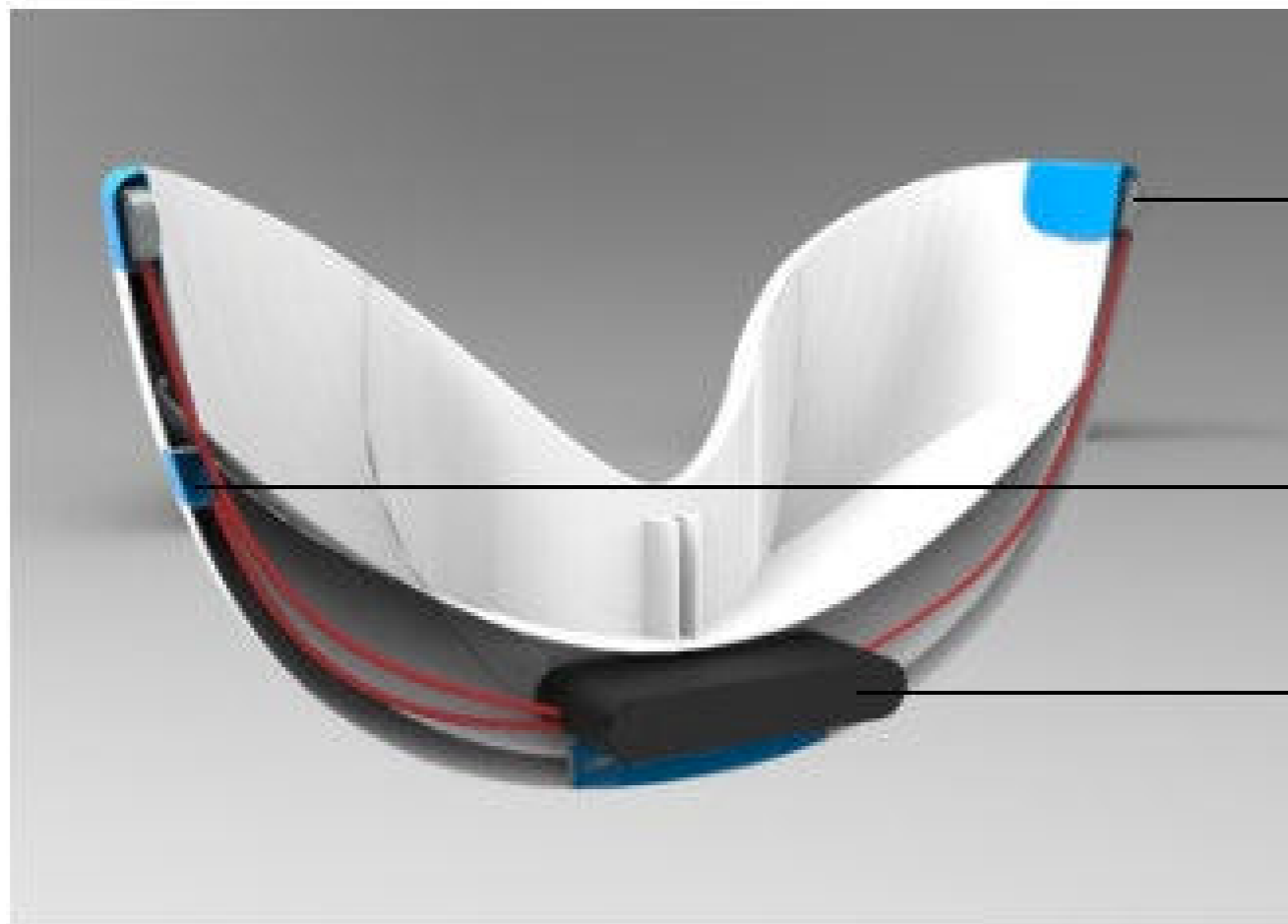

Vibration motor

charging port

li ion battery