

PROJECT III

HYBRID LIGHTING

Guide
Prof.Kumaresan

By VVinoth
126130005

07.03.13

Study and
Research on

Research and
understanding of

Creation of

Lighting

Context

Concept

Off the grid
Power Sources

DesignBrief

Prototype



Lighting

Light

This is the only radiation which is visible to human eyes which makes us see things

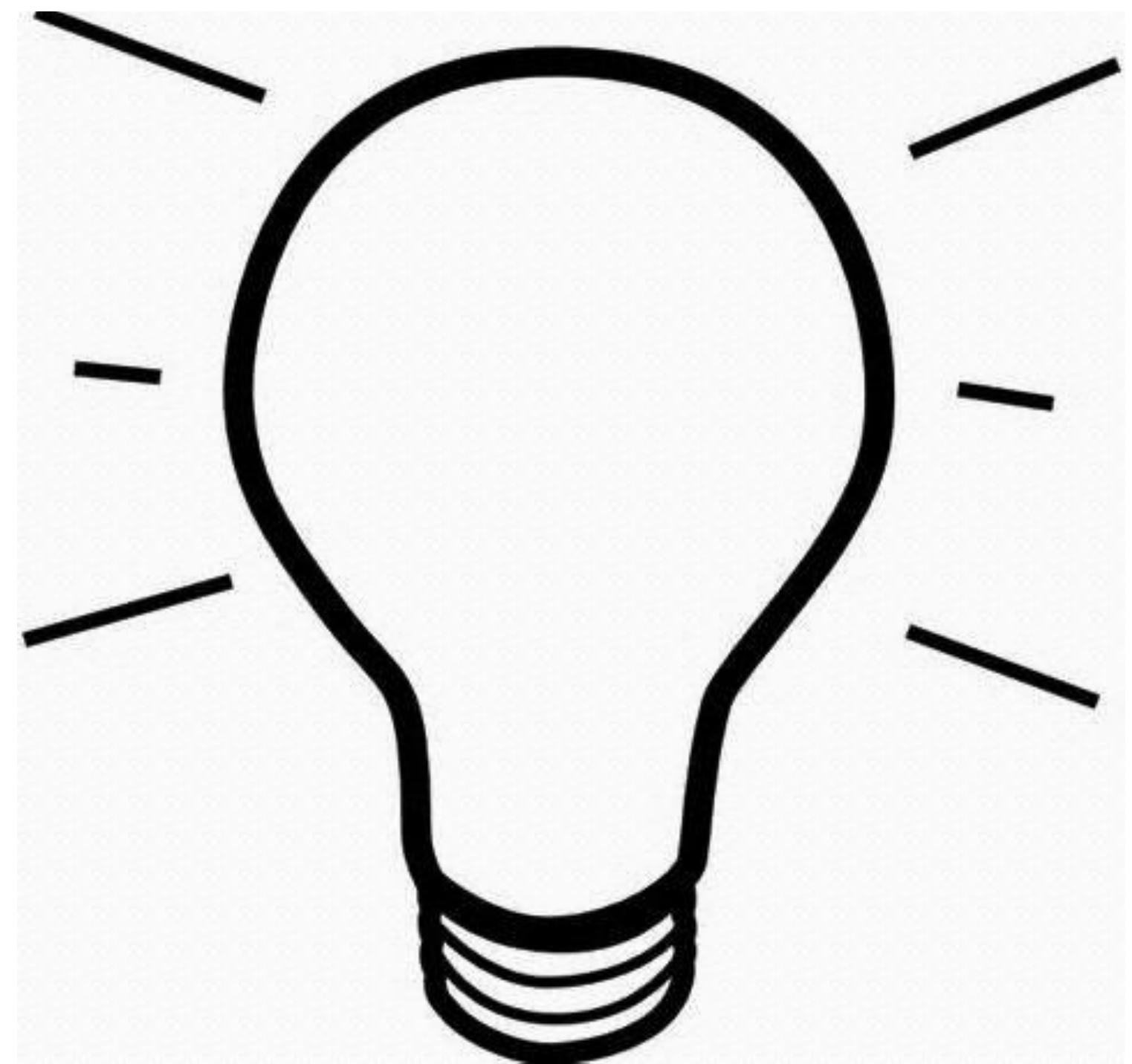

Light

This is the only radiation which is visible to human eyes which makes us see things

Sight
Vision
Color
Illuminance
Contrast
Adaption
Glare
Measurement
Photometry
Health effects

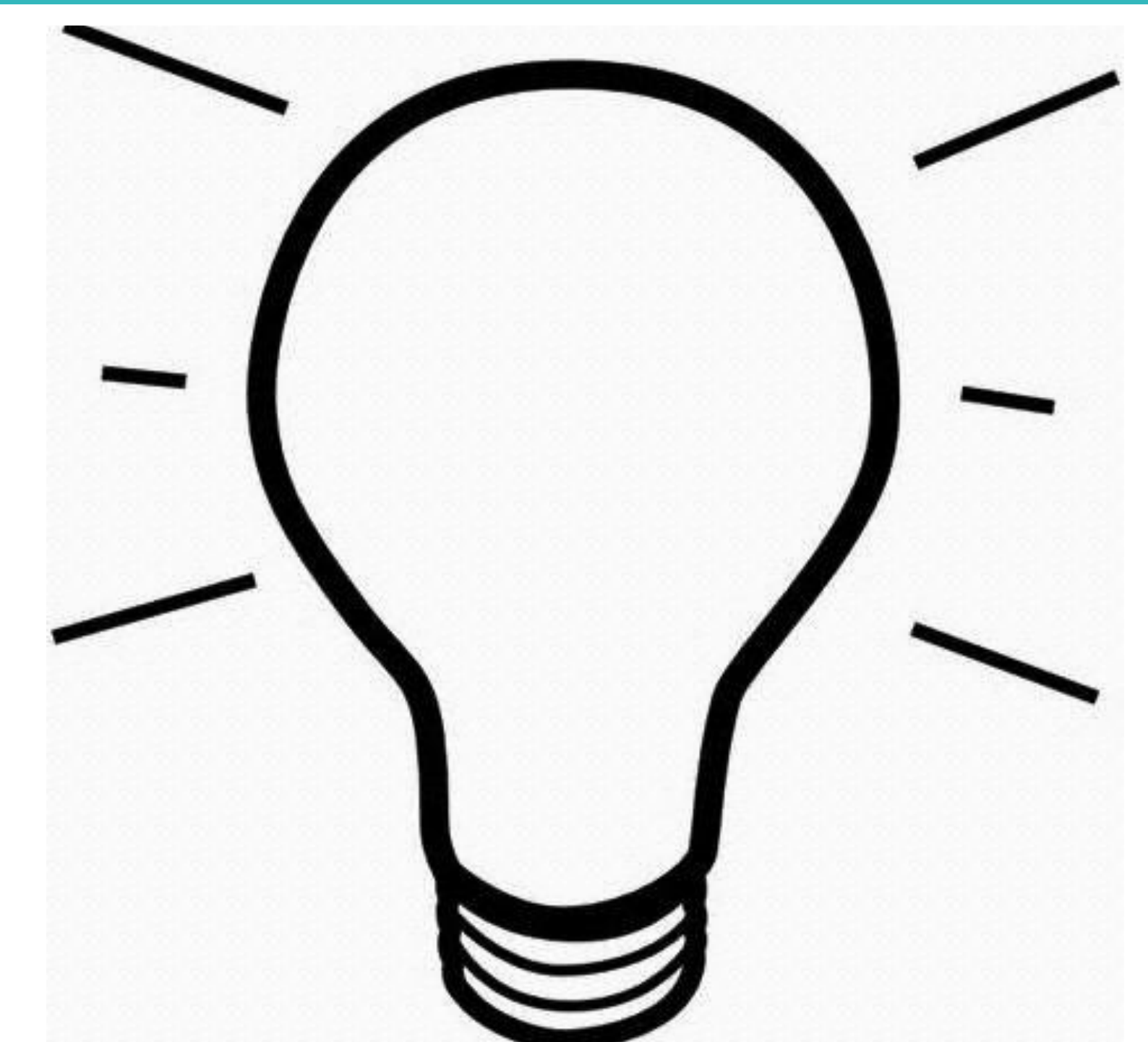

Lighting

Deliberate use of light to achieve **Practical** or **Aesthetic** effect



Natural light

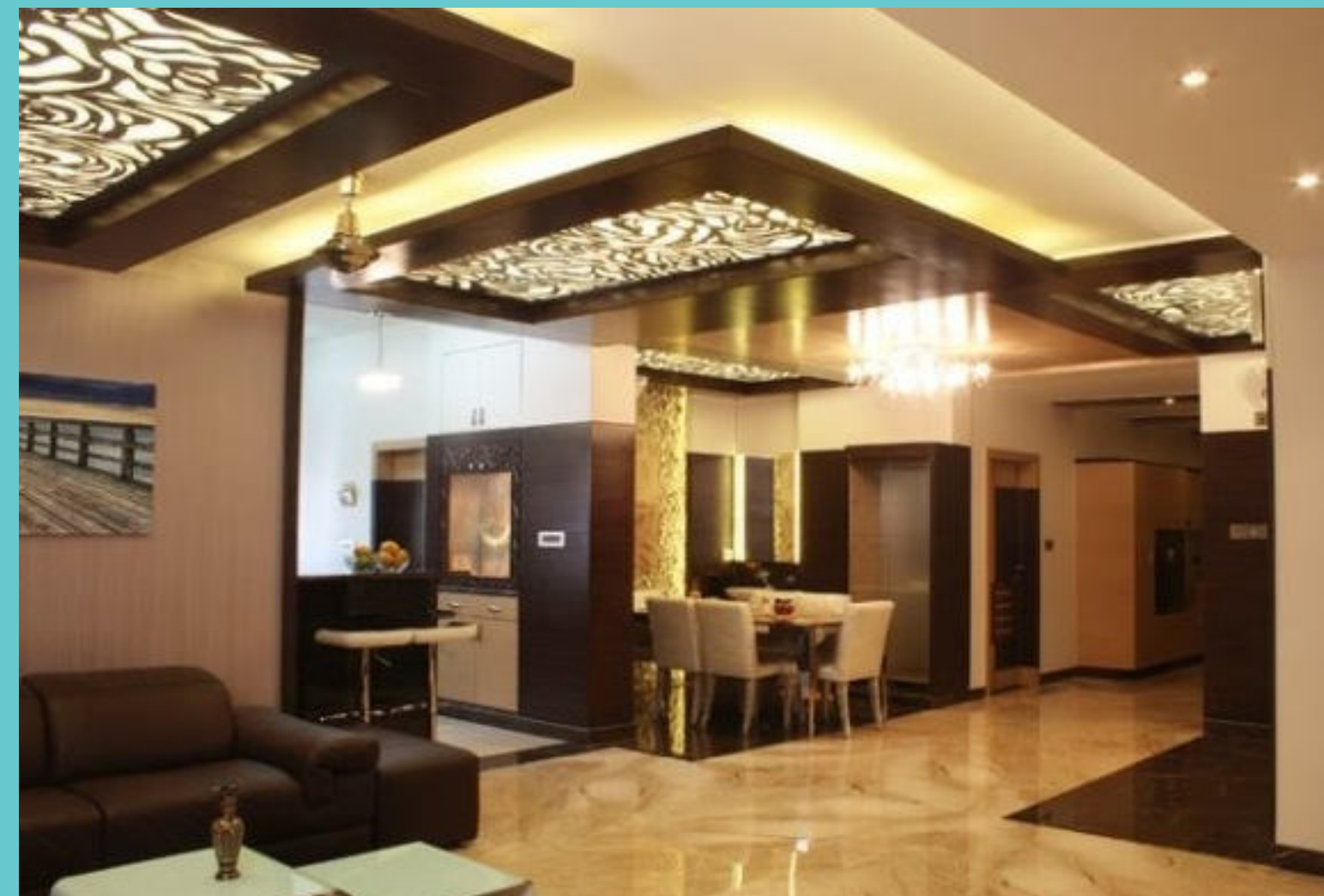

Artificial light

History of Lighting



Lighting Systems



Accent light



Task light



General light

Lamps



Luminaire

Device used to create artificial light

Different fixtures & positions

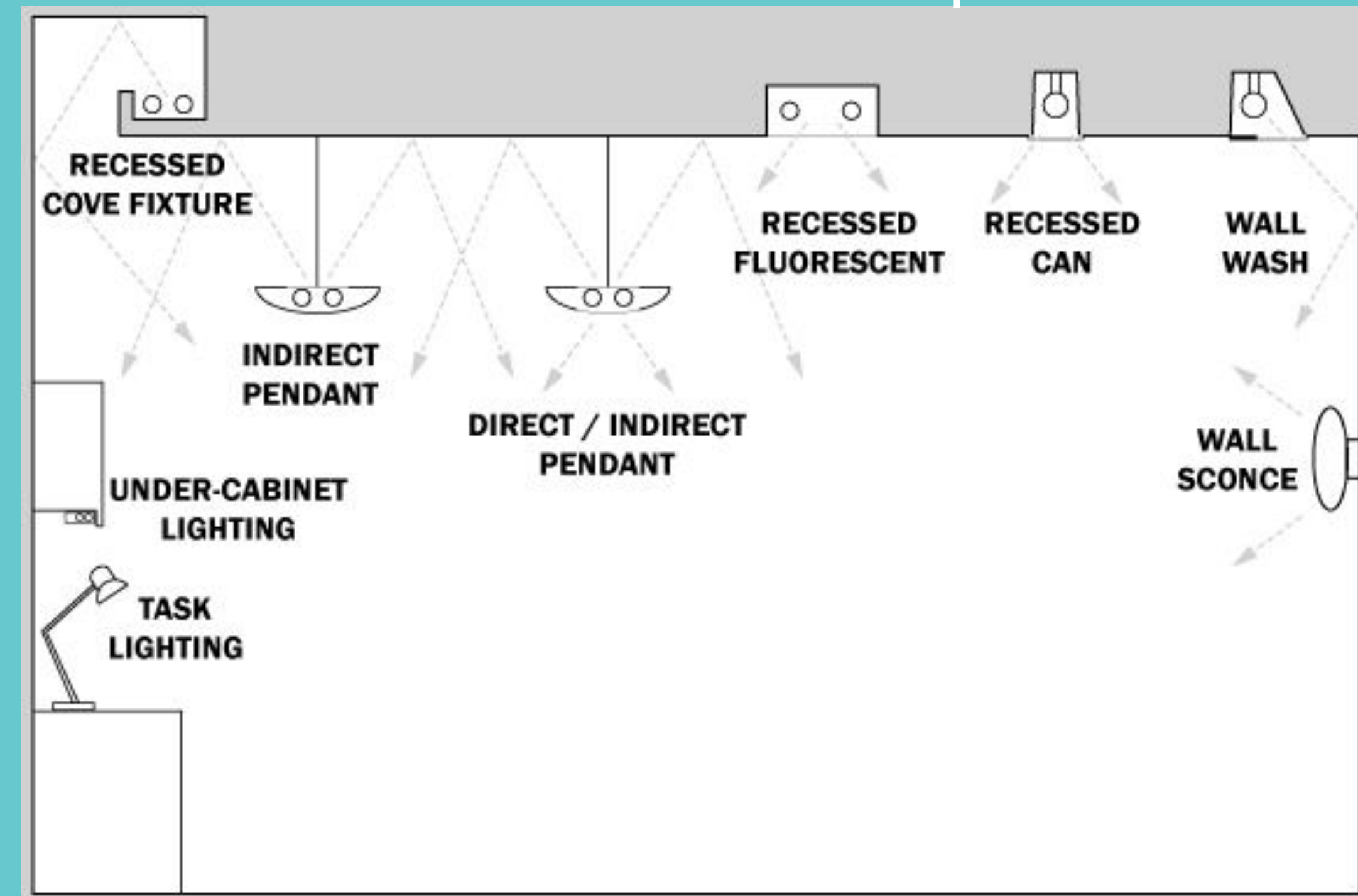

But

But

what is so
common

about all these..

But

what is so
common

Everything is

about all these..

Grid
connected.

But

what is so
common

Everything is

about all these..

Grid
connected.



Non
conventional
Lighting

'Off the Grid'

Solar Power

e

It is the free abundant source of energy available during day time, which is harvested through PV cells and stored in battery for different application.



The power extracted depends on the size and property of the panels

Solar Power

+ Best Renewable energy abundantly available
Green, clean energy.
Advancing technology.
Best Off the grid solution.

- Seasonal
High Initial cost
Solar Inefficiency
Storing Solar energy



© Clear Prospects Limited 2010



Gravity light

e

Gravity light is a mechanically operated gravity powered lamp as a replacement for kerosene lamps in third world countries



It takes 3 sec. to lift the weight of rock or earth attached to it, which slowly descends creating 25 minutes of light similar to a cuckoo clock.

Gravity
light

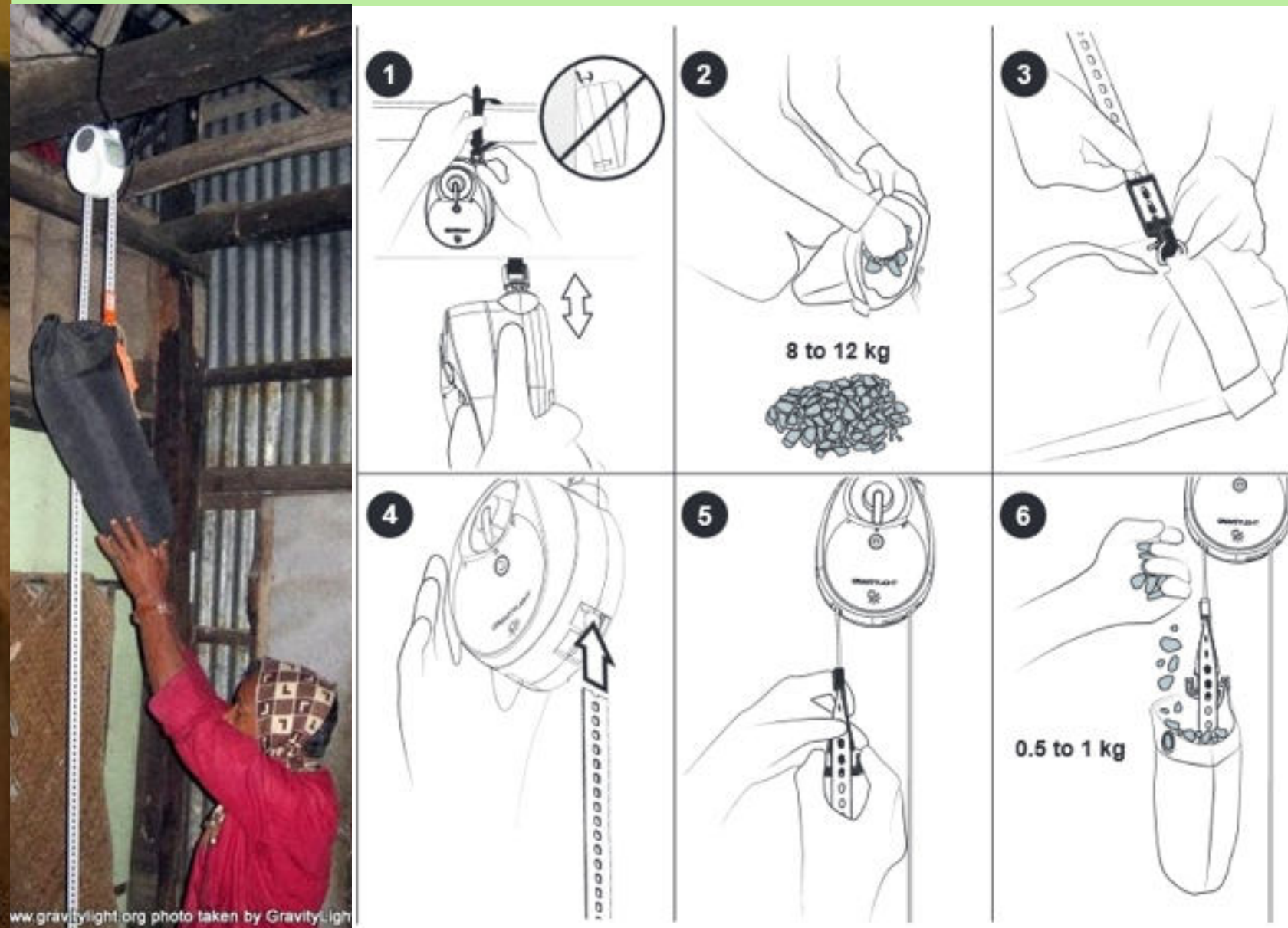
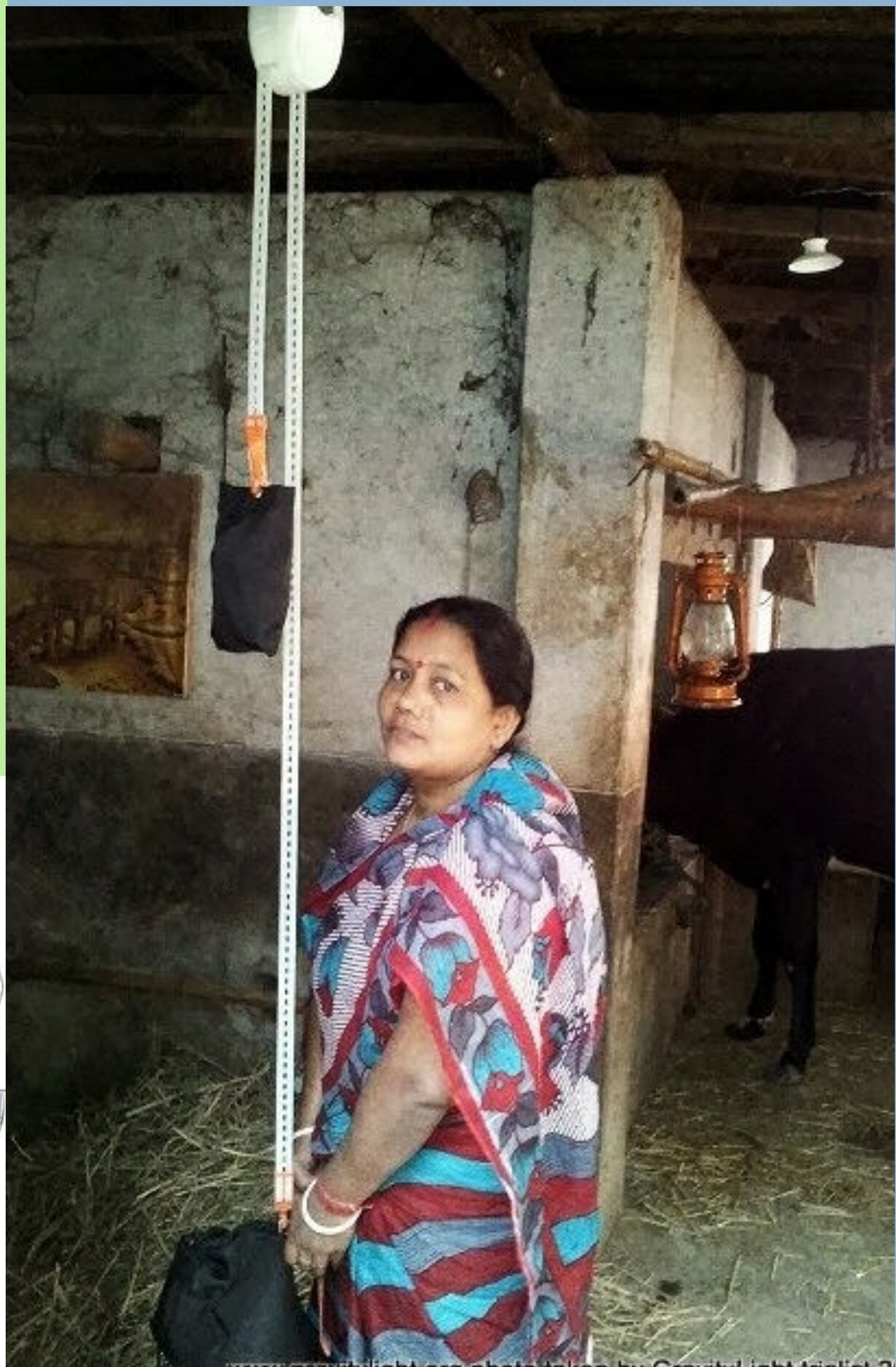

Gravity light



- + Self sufficient
- Low cost
- Energy harvesting
- Self reliant

- Devoid of portability
- Difficult for old people and children to lift 20kg weight
- Have to reload it every 25 minutes

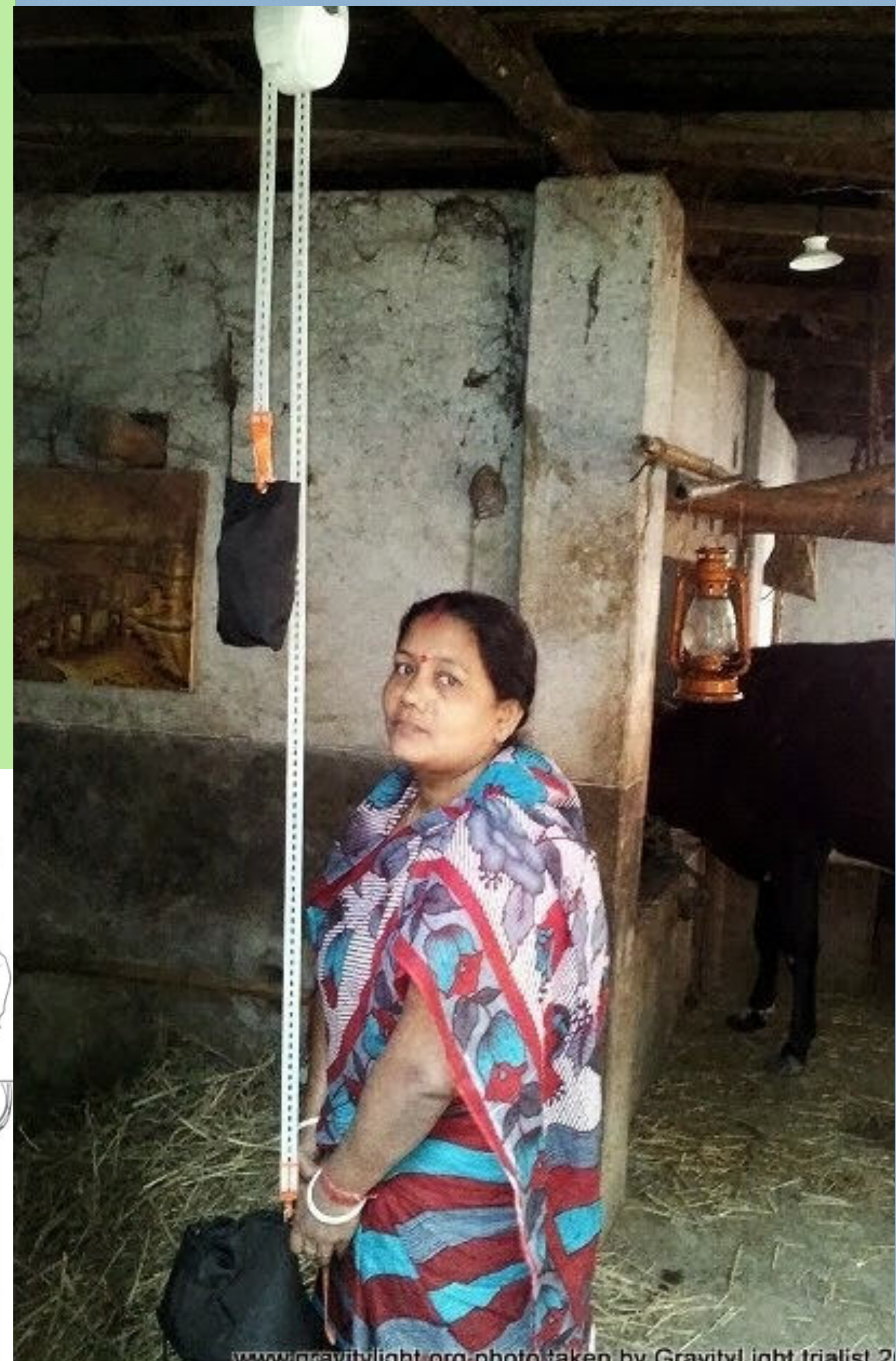
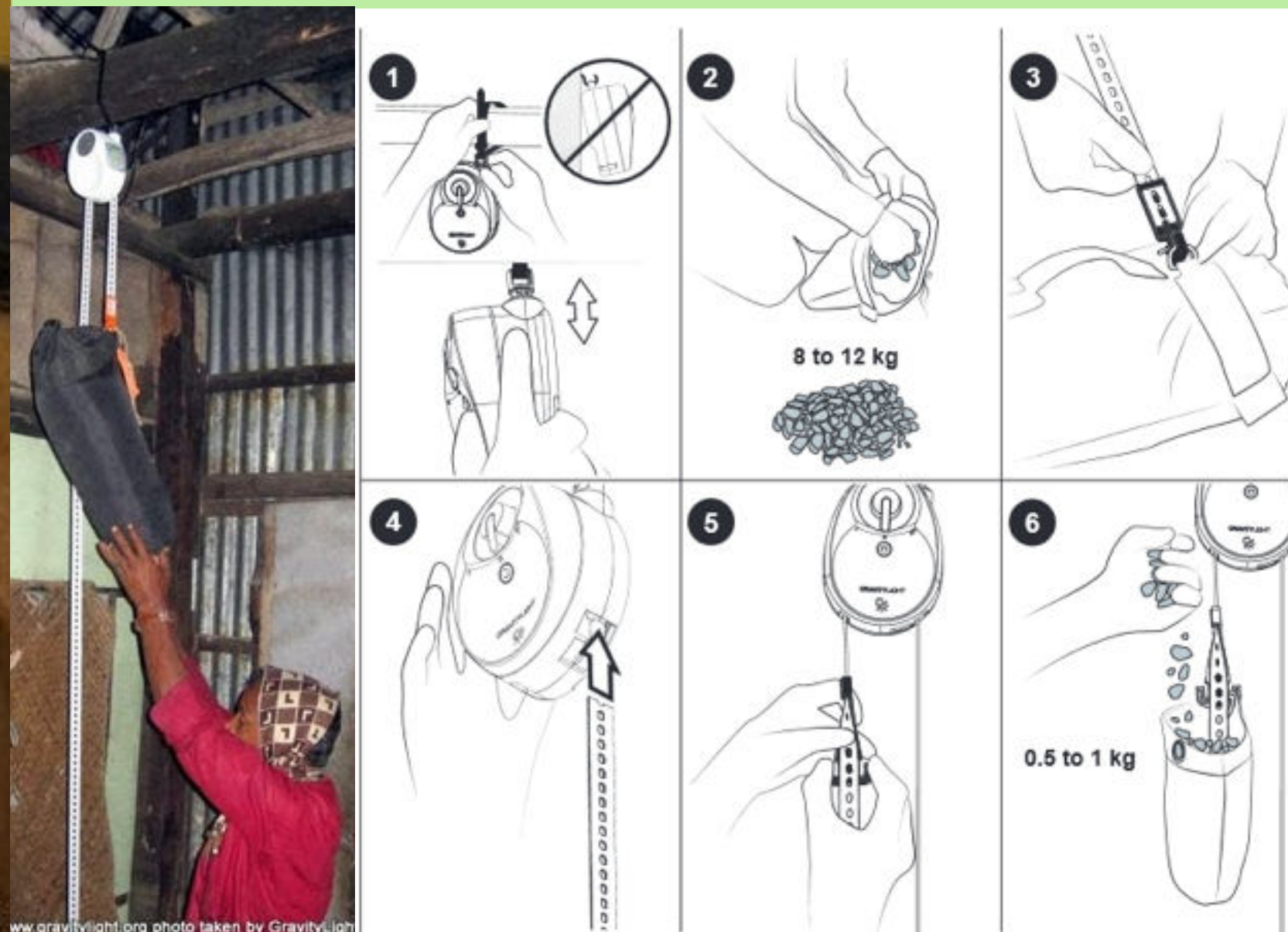

Piezo electricity

e

It is the charge accumulated in certain solid material in response to applied mechanical stress.

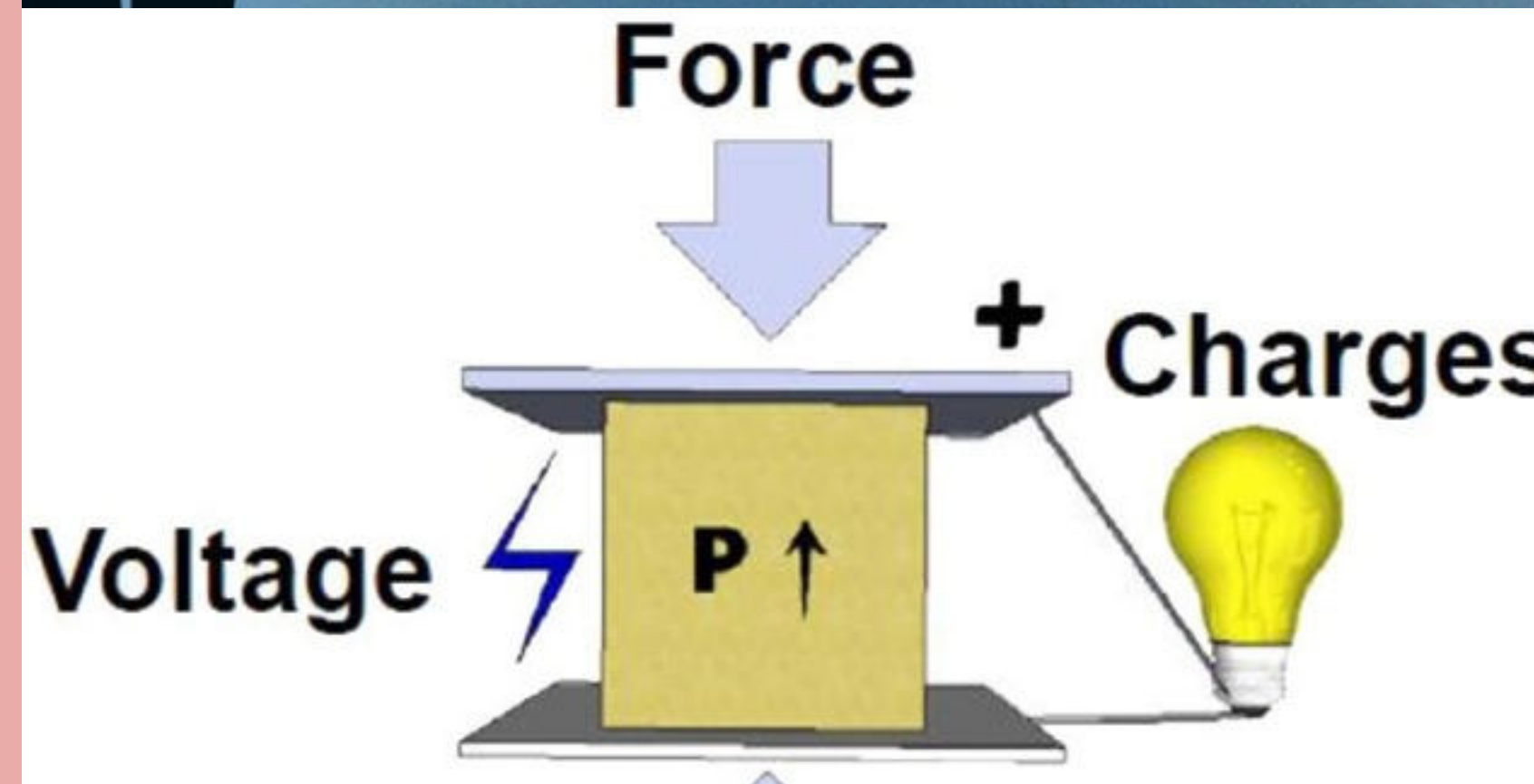

It is becoming popular in energy scavenging mostly for wearable devices and centralised body worn power packs charging. which is a shift form the industrial and commercial application.

Piezo electricity

e



Piezo electricity

e

⊕: Convenient way of producing power by our daily activities. Efficient energy scavenging.

⊖: Not a cost effective solution. Continuous human labour needed. Storage of energy.

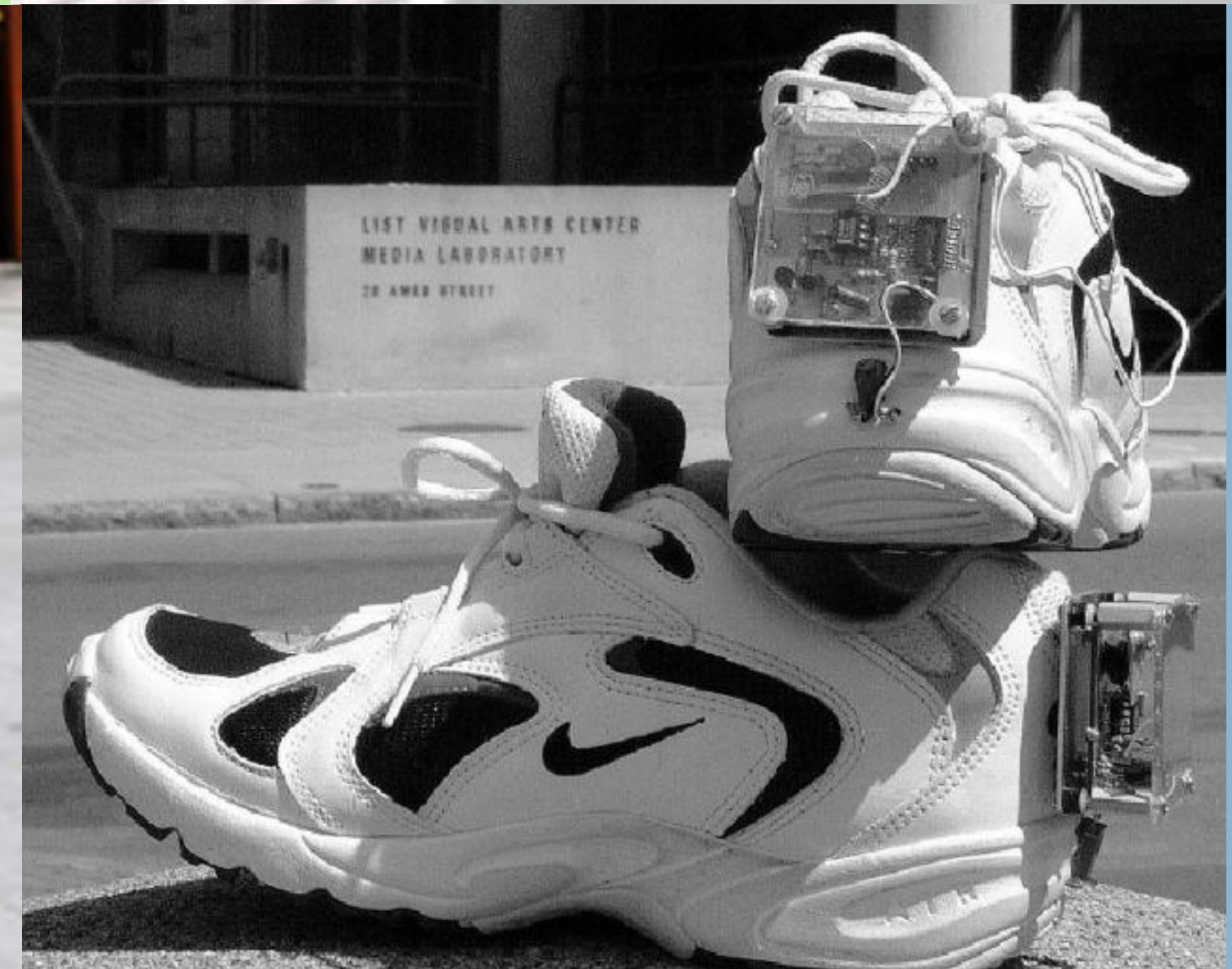

Wind power

e

It is the conversion of wind energy into useful form of energy



Wind power acts as one of the main contributor for Off the grid system and for alternate power.

Wind power



e

Wind power



⊕: They are green and free source of energy
Less maintenance.

⊖: Highly seasonal
less portable options
High initial cost.
Non dependable.

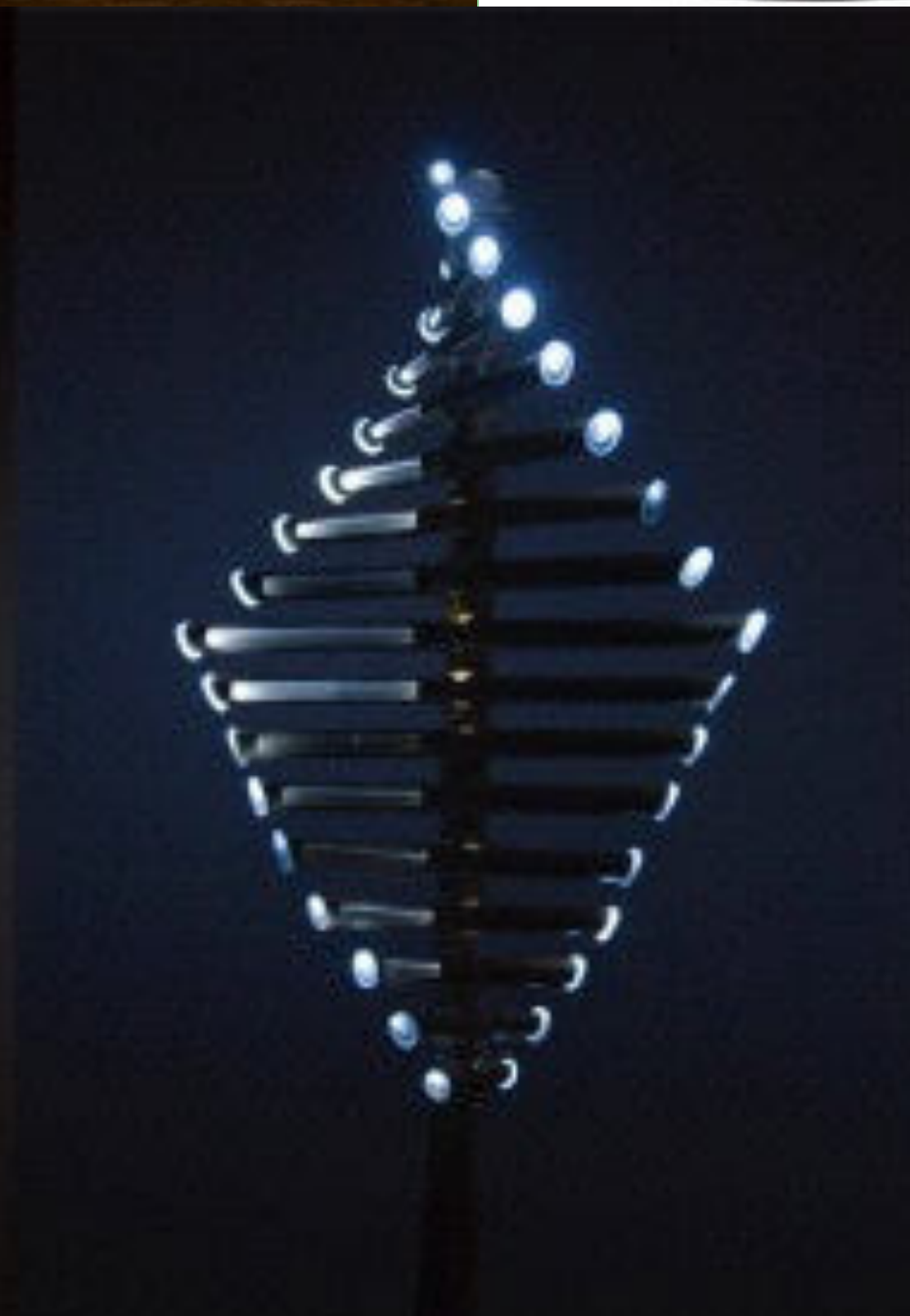

Human power

e

It is the conversion of muscle power (physical action) to charge the battery through a dynamo or magnetic induction by shaking ,cranking, pedalling, etc.

Bodily parameters are also sometimes used to work for wearable devices.



This is used in wide variety of application from charging lamp,radio, kitchen appliances, as emergency, power saver and rescue operation. Powering electronic devices using human power is one of the trending research topic.

Human power

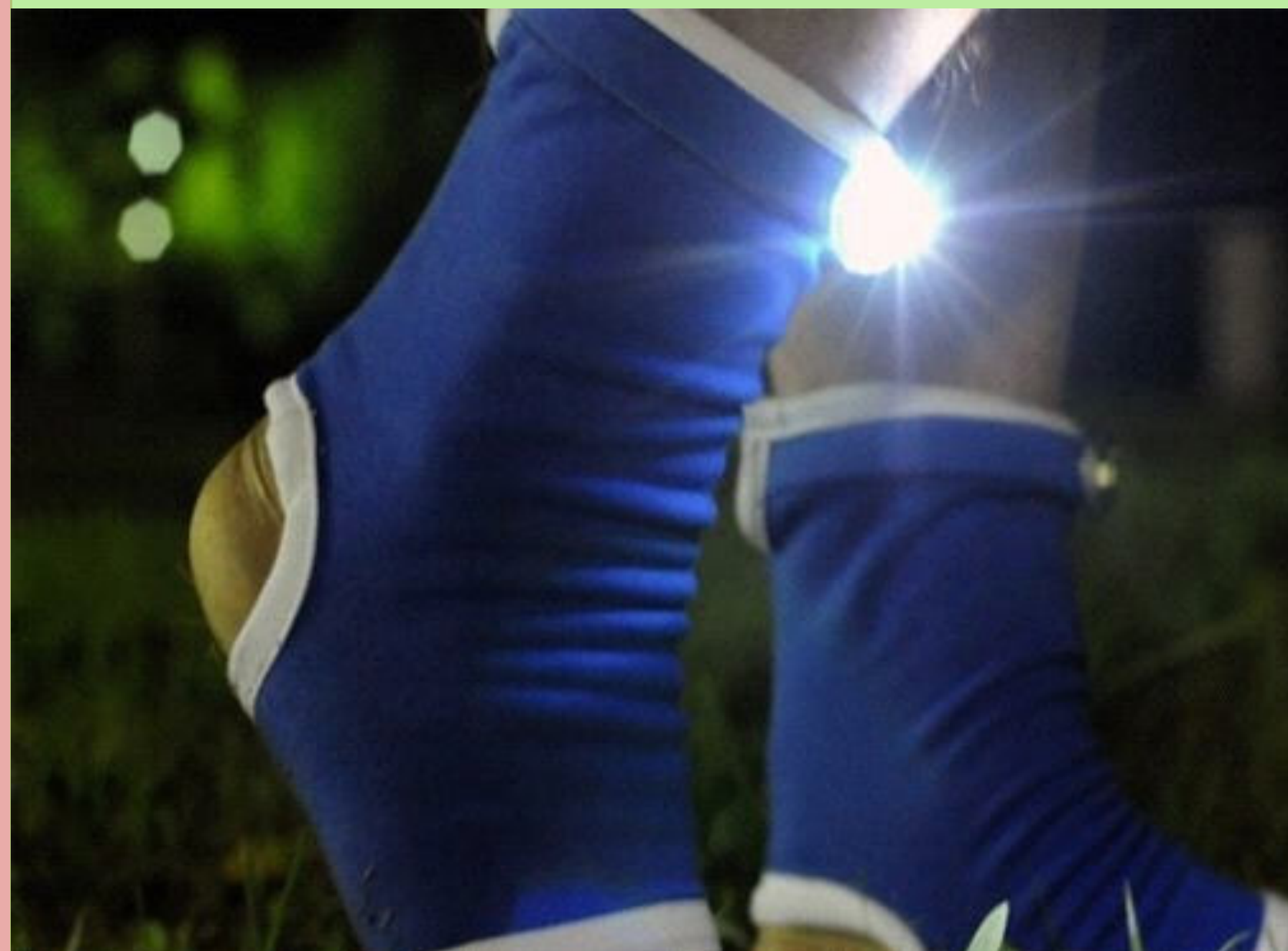

Human power



e

+: Best alternate source of energy. during emergency. Highly dependable and portable. No wastage of batteries.

-: Efficiency depends upon the person. Continuous human labour



Soil Power

e

Soil basically acts as the medium of electron flow or soil creates the electrons which is harvested by inserting a cathode and anode rods (graphite and chicken mess) which are internally connected to a battery through a power regulator.



The power is sufficient to light 1-2 LED's for four to five hours per evening.

Soil power

e

⊕: Easily available raw material for power generation.
Eco friendly self sustaining solution.

⊖: Have to keep it dry every often
Power generation depends on the area of the graphite sheet.

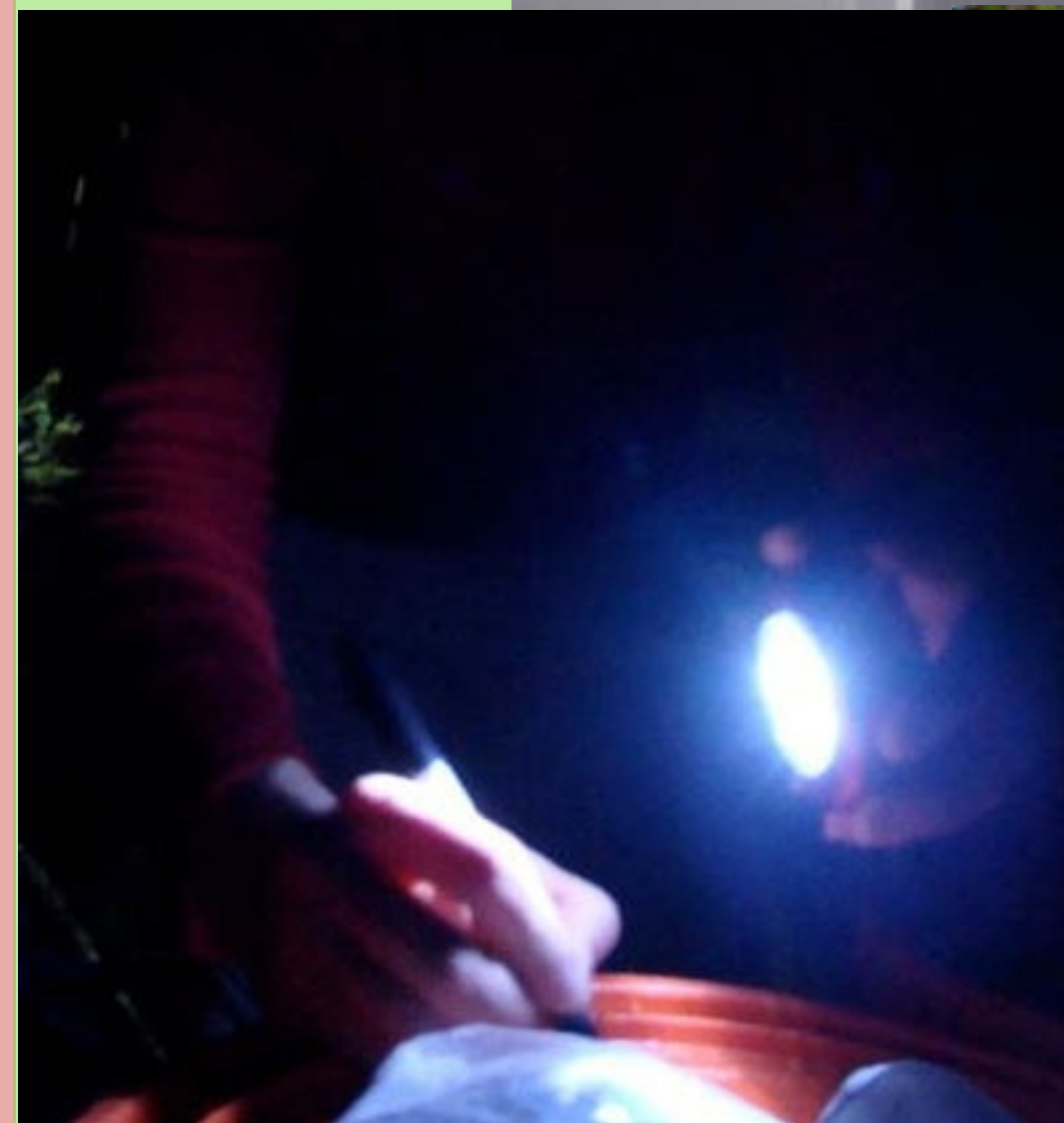

Liter of Light

e

Lighting using the refractive property of water inside a bottle to light the dark interiors during day time.

It produces power equivalent of 55watt light bulb



Bleach is added to the water to keep the water pure from bacteria and fungus.
This is a open source project installed in many parts of the third world as efficient day lighter and alternate for incandescent lamp.

Liter of
Light

e



SOLAR BOTTLE LIGHT is a good source of daylight--
up to 55 watts

Liter of Light

e

⊕: Self sufficient.
Very low cost.
Zero carbon emitting.
Highly efficient.

⊖: Problem in sealing the bottle.

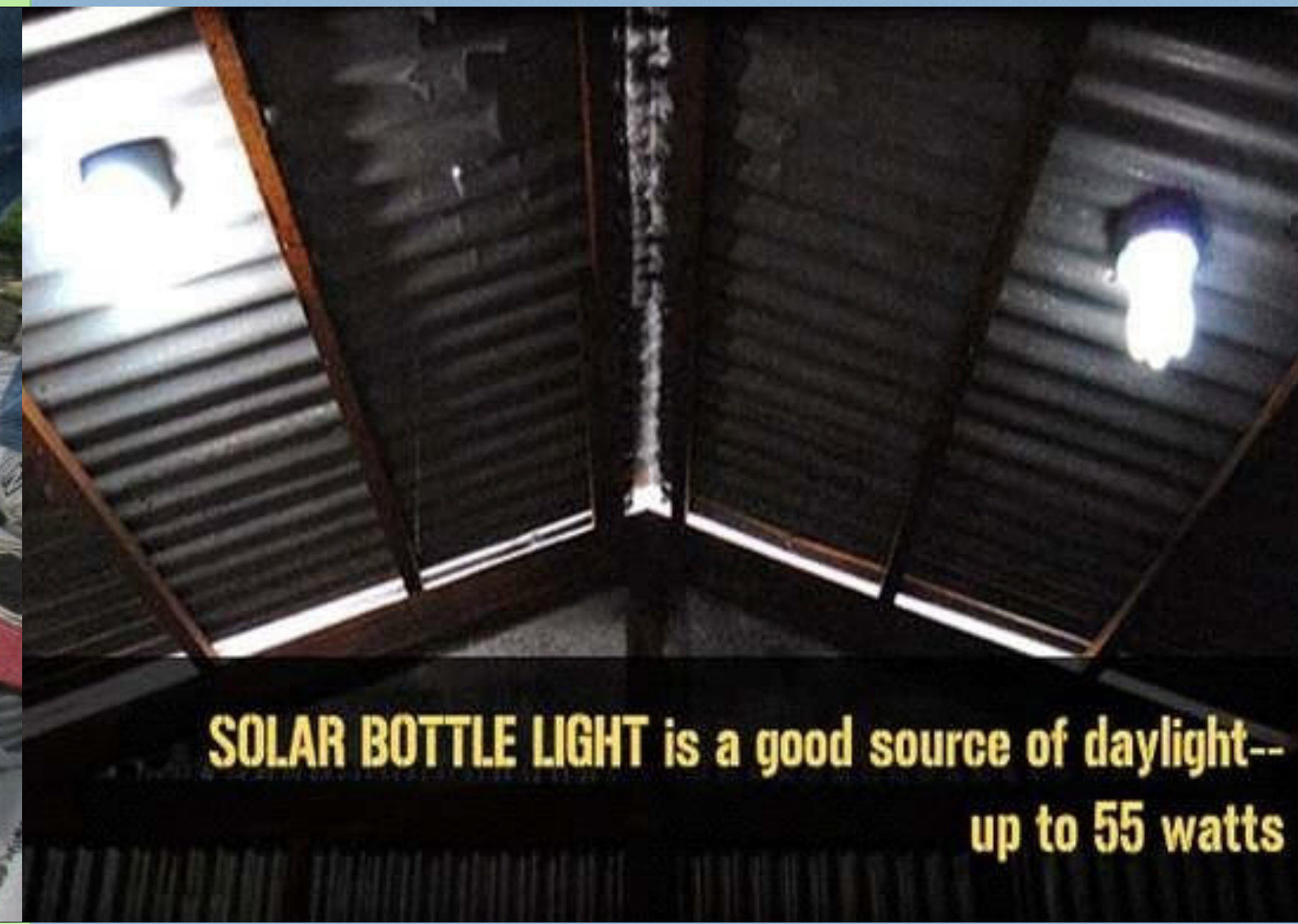

SOLAR BOTTLE LIGHT is a good source of daylight--
up to 55 watts

Hybrid light

e

Hybrid lighting is bringing the natural light in to the interiors through a collector pointed towards sun during the day and electronically feeding with the artificial light during night and low light day.



It is getting popular among the housing societies and commercial buildings in US. The solution requires a system level change.

Hybrid Light

e

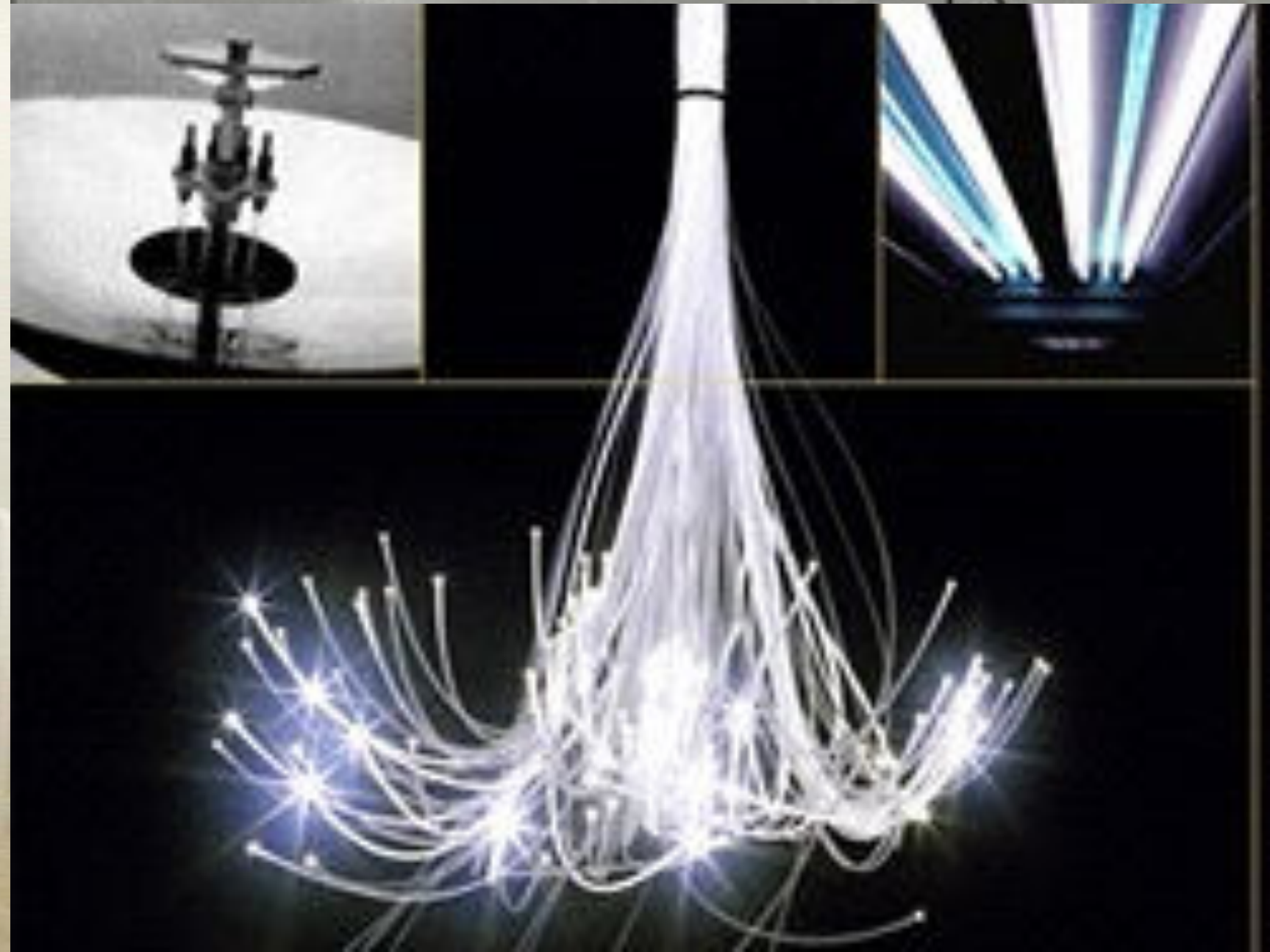
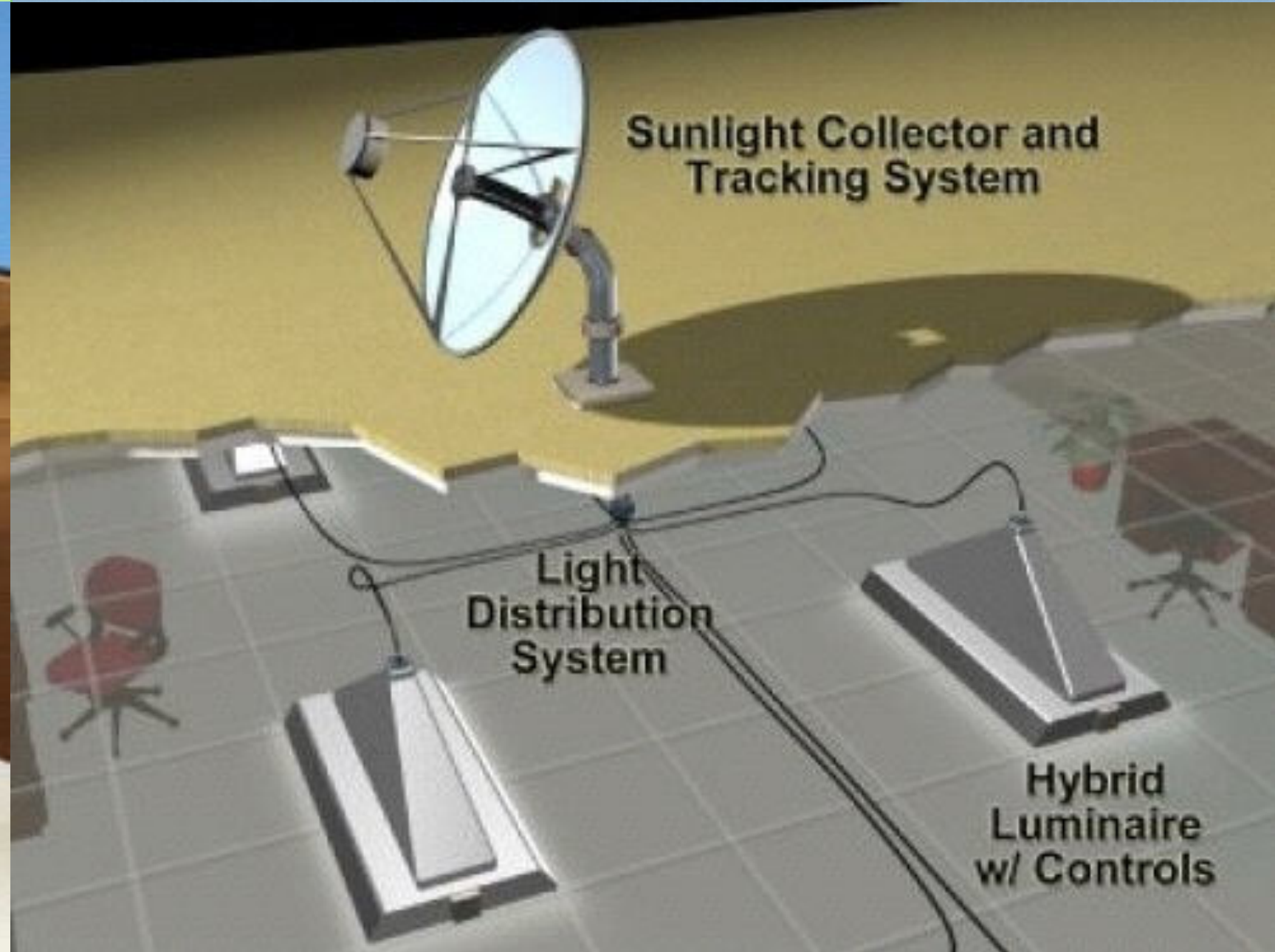
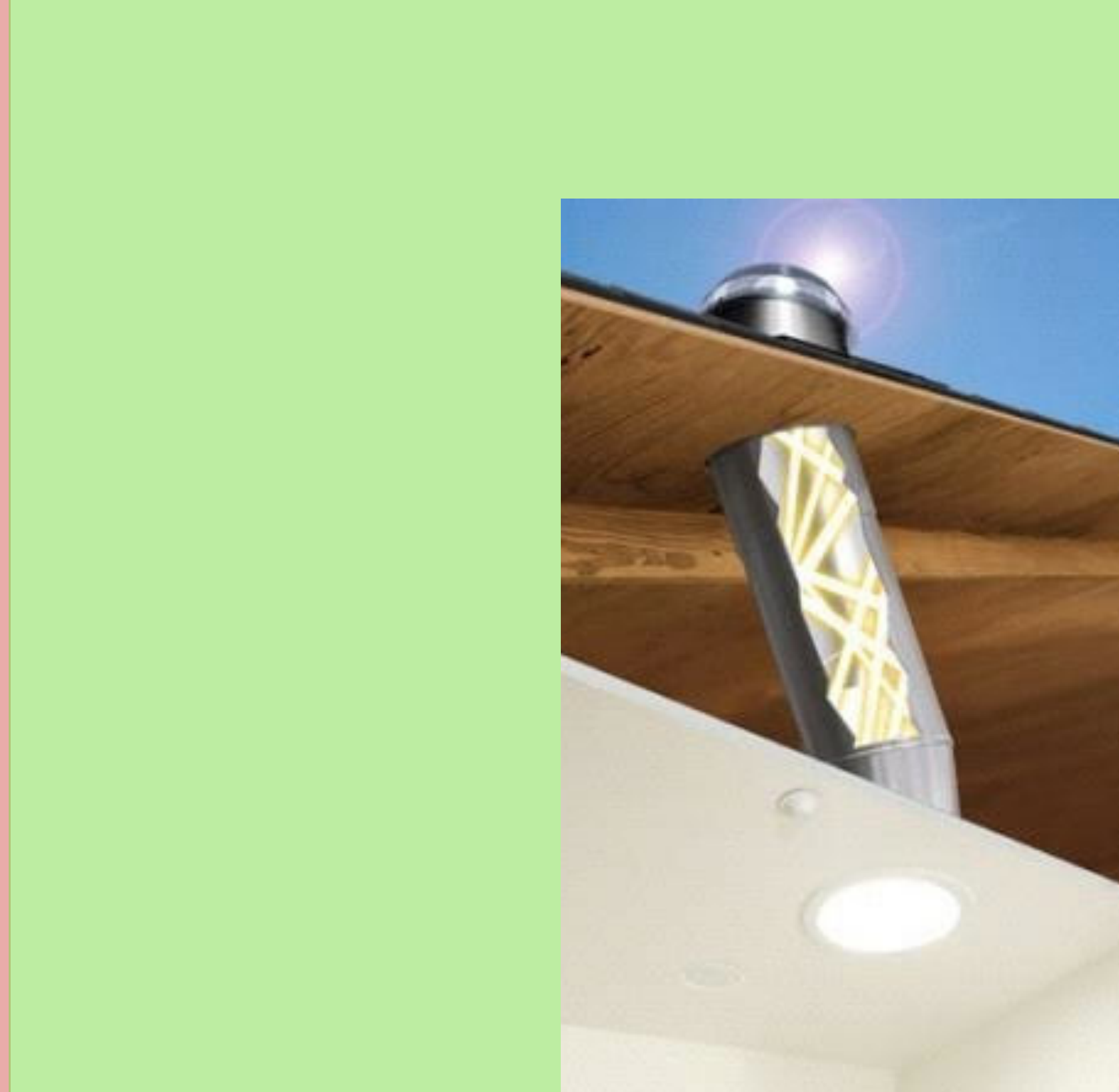

Hybrid Light

⊕: Saves power bill.
Health benefits.
one collector can supply
for the whole house.

⊖: Not a cost effective solution
Requires alteration in the building
Fiber optics technology for light
haven't reached its optimum.

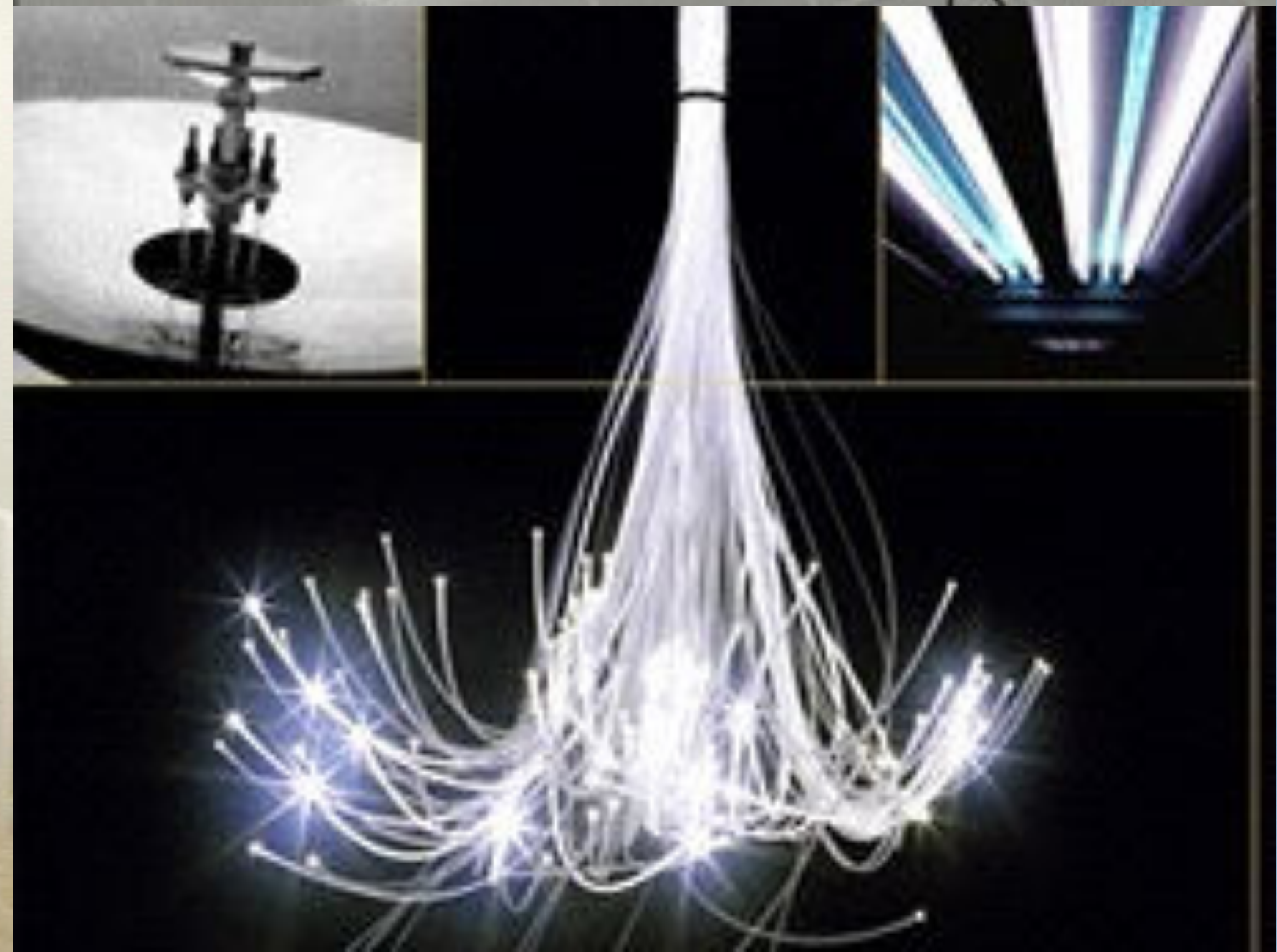
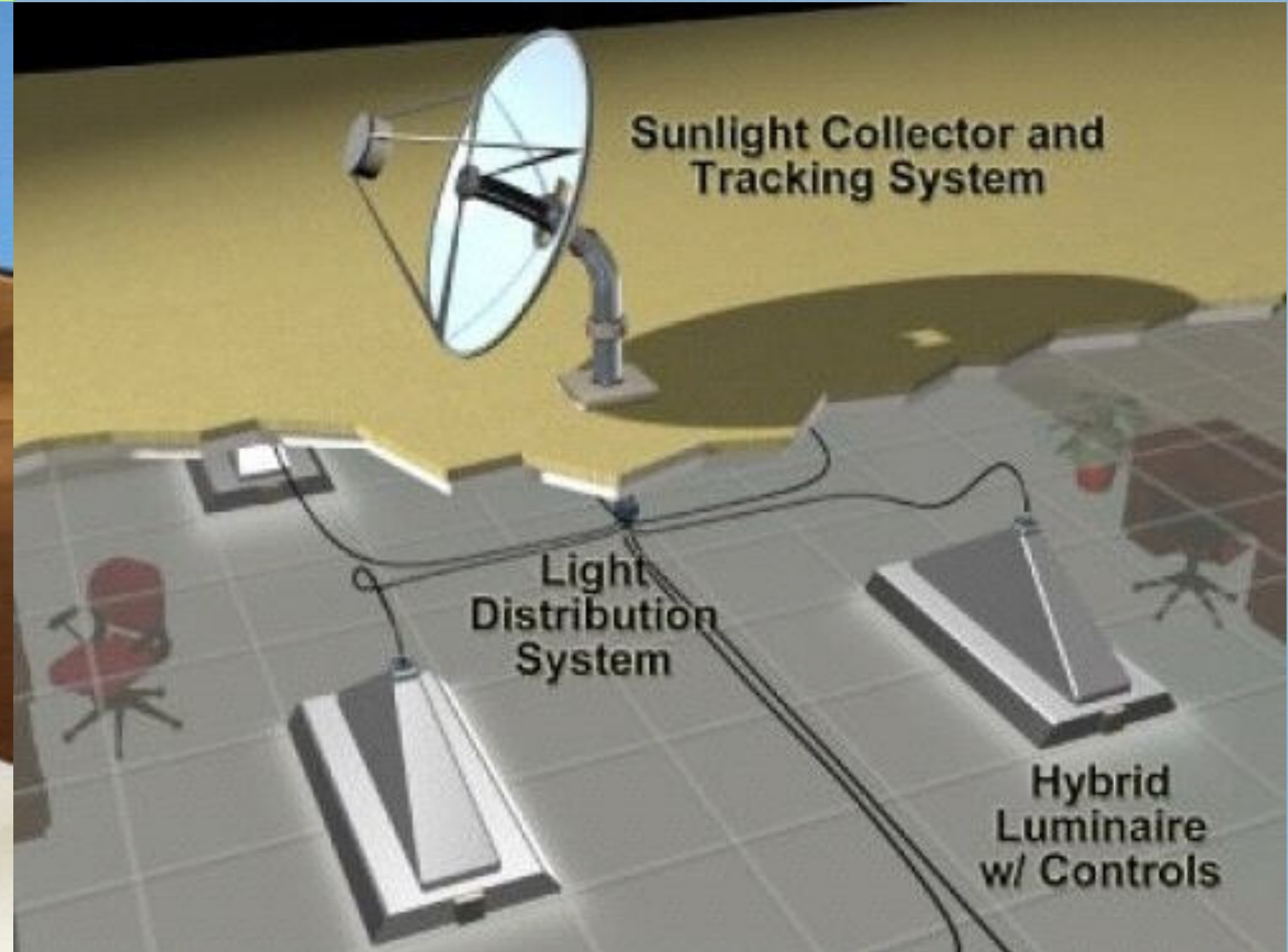
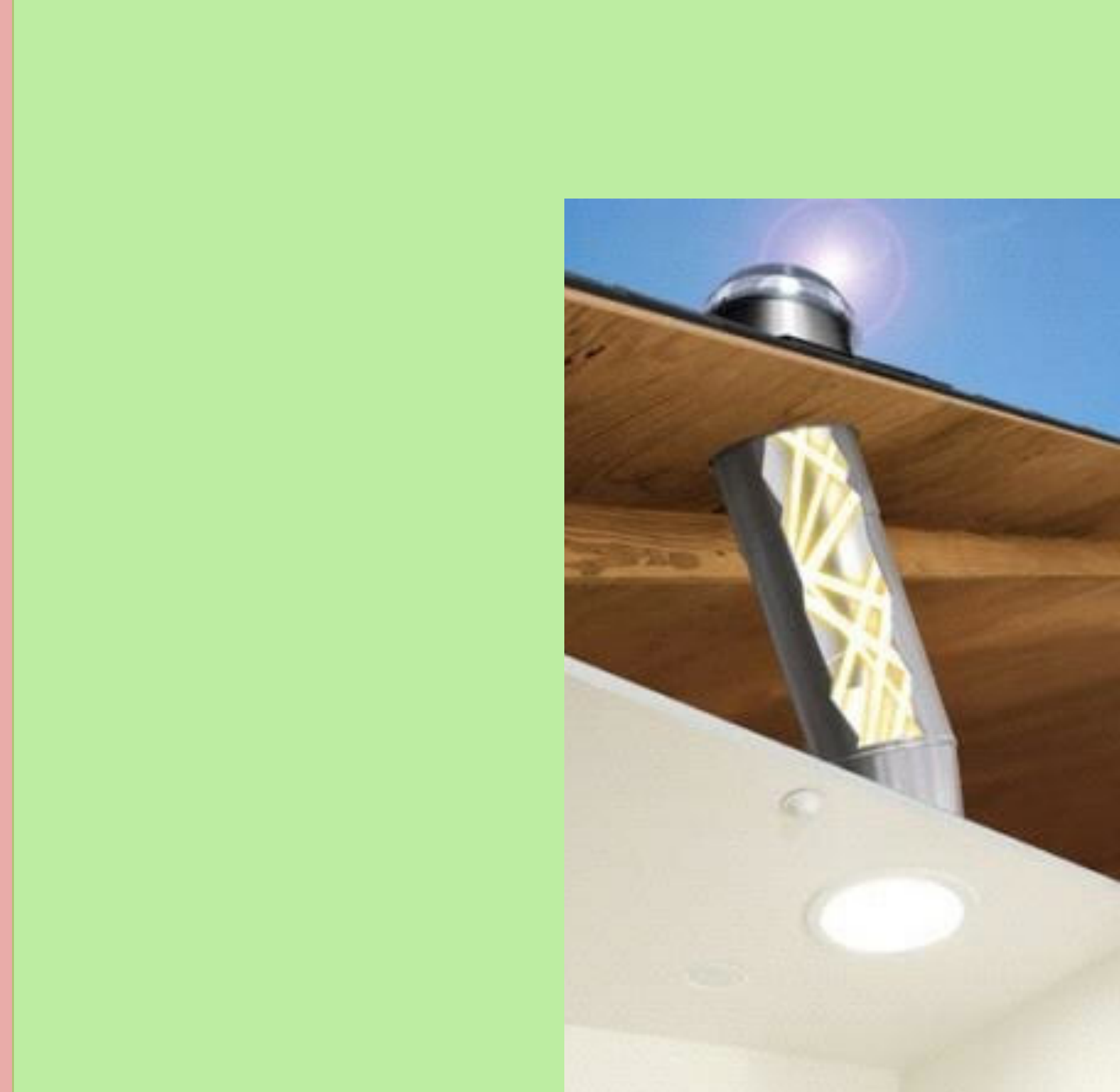

Thermo electric Generator

Thermoelectric effect is the direct conversion of temperature differences to electric voltage and vice versa. A thermoelectric device creates voltage when there is different temperature on each side.



They have a use in power plants and in automobiles as automotive thermoelectric generators (ATGs) for increasing fuel efficiency. Space probes often use radioisotope TEG's

Thermo electric Generator

e



Thermo electric Generator

Pros:

The sensor is very light and modular,
Scalable upto the required temperature.
Maintenance is easy.

Continuous operation in any climate
(hot, cold, wet, dry)

-:

Module is very expensive
because of lesser production.
Efficiency of the device is low,
around 6%-8%.



Hybrid Light

e

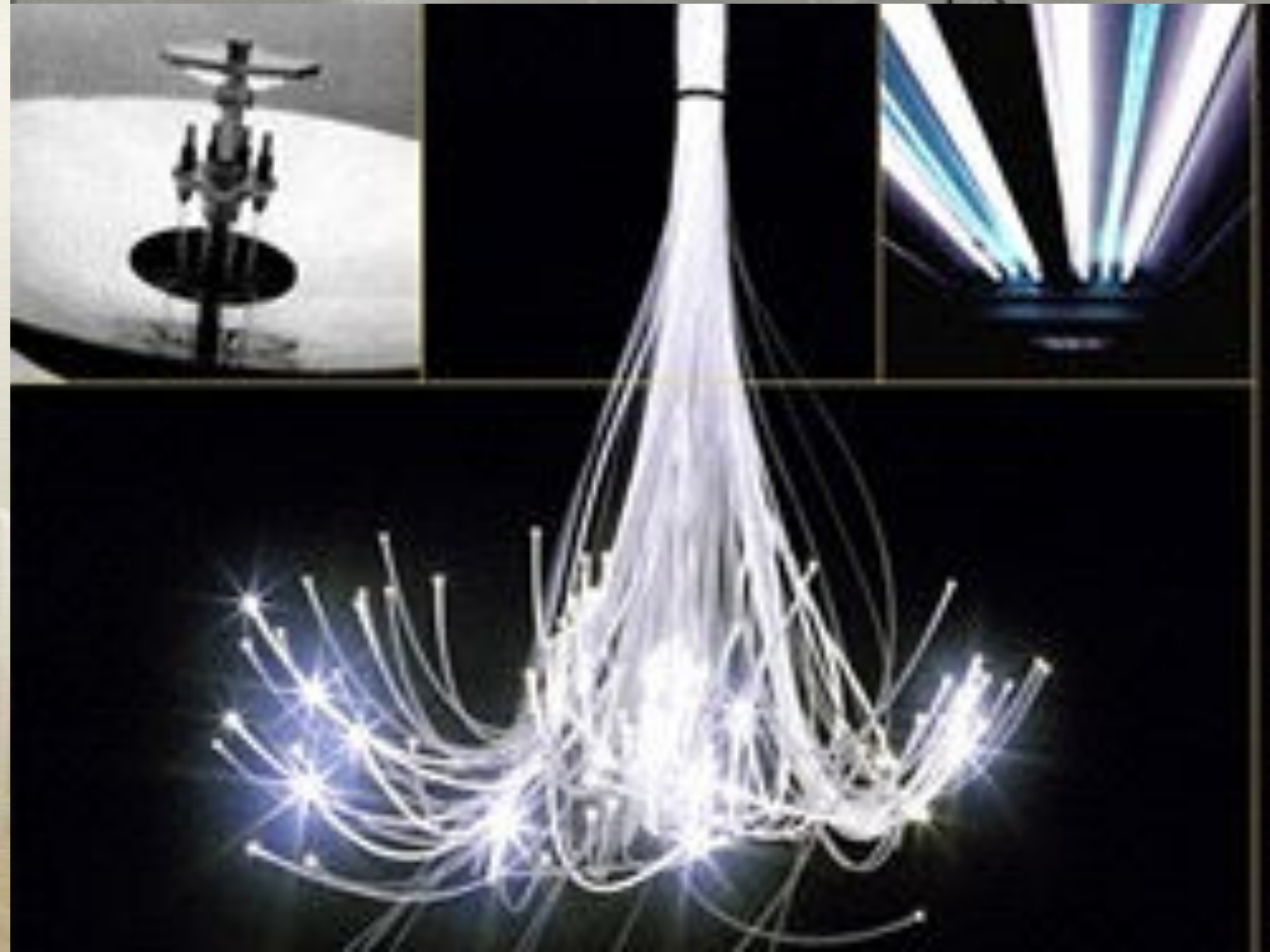
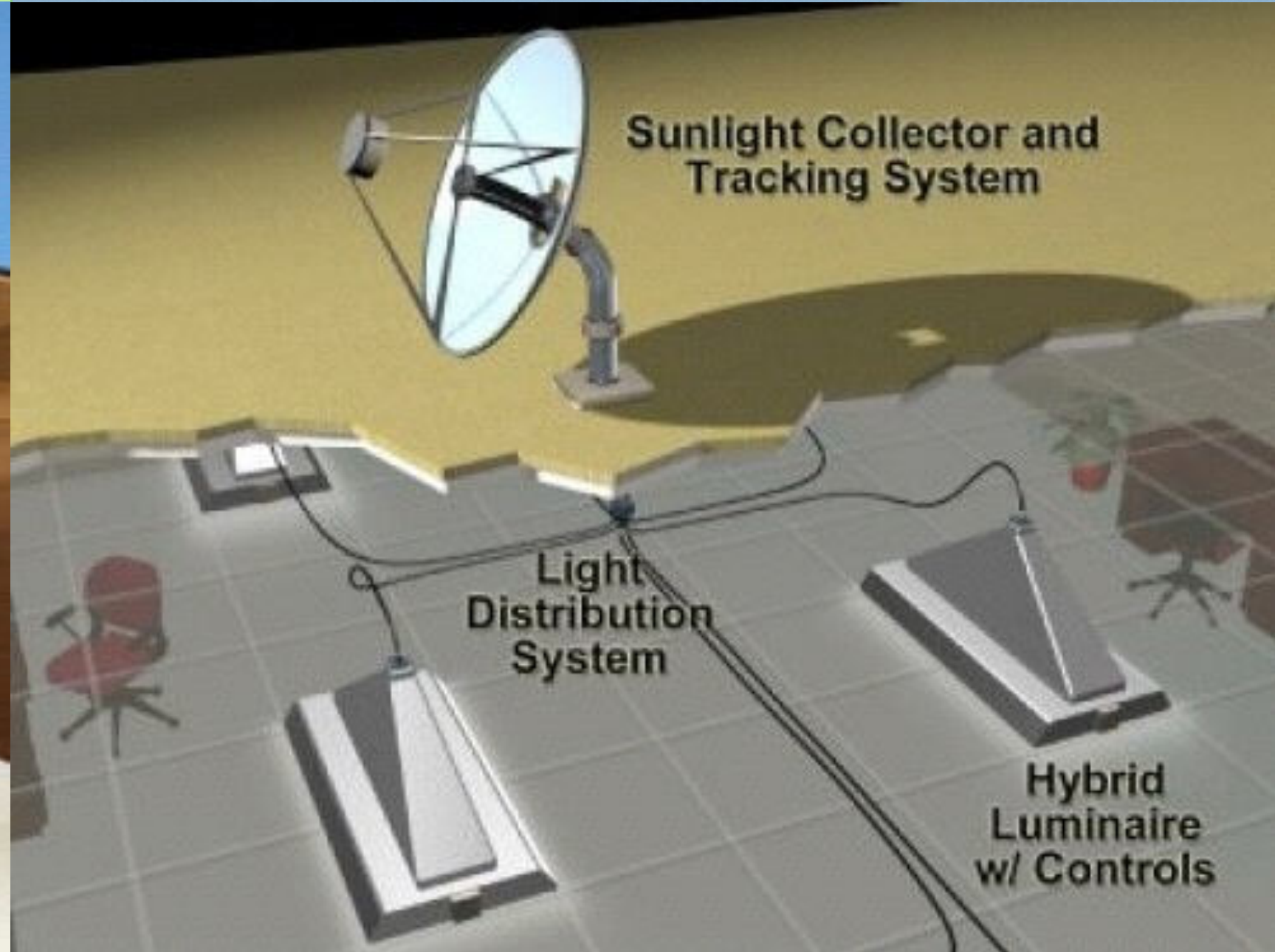
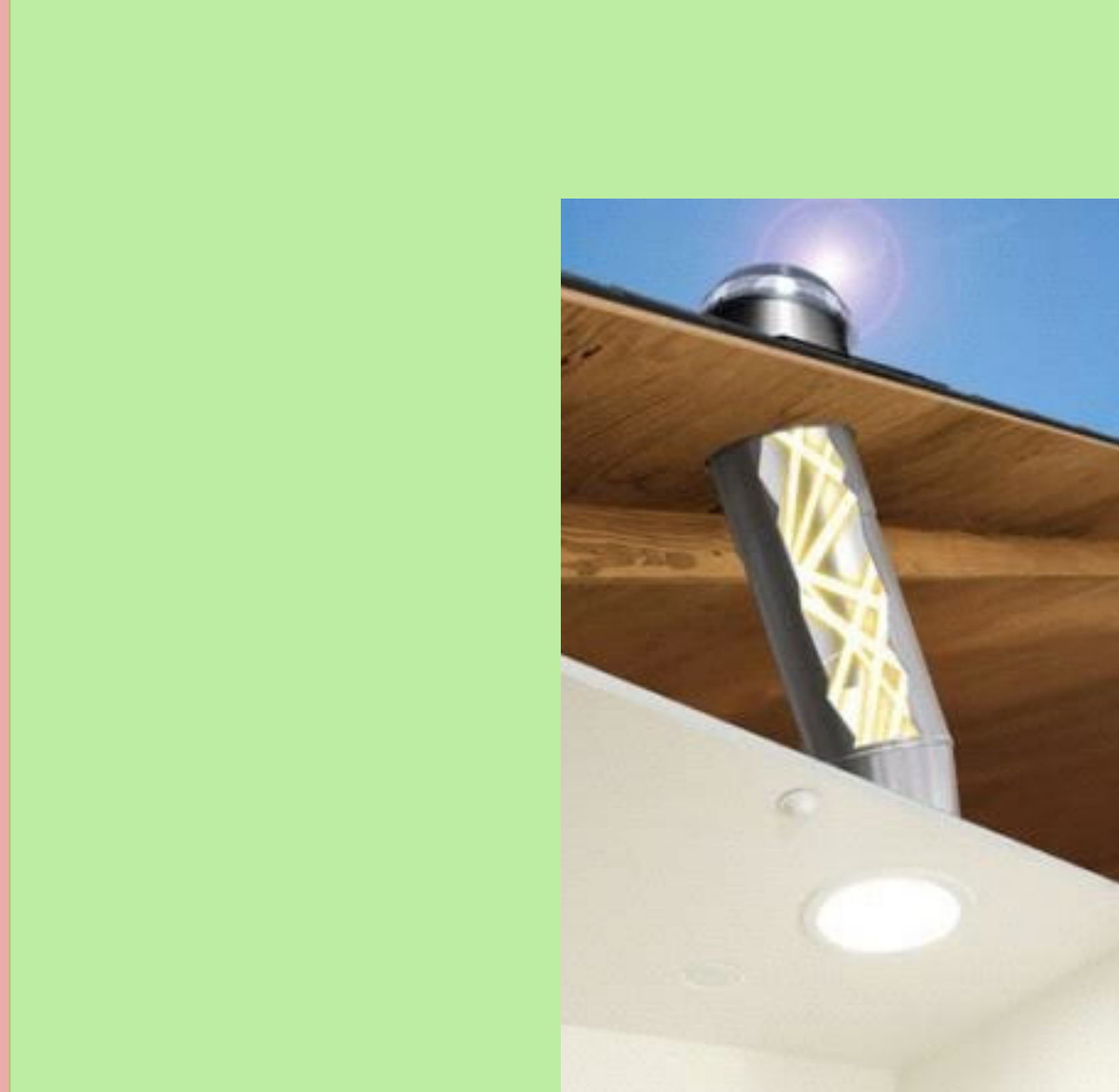

Hybrid Light

⊕: Saves power bill.
Health benefits.
one collector can supply
for the whole house.

⊖: Not a cost effective solution
Requires alteration in the building
Fiber optics technology for light
haven't reached its optimum.

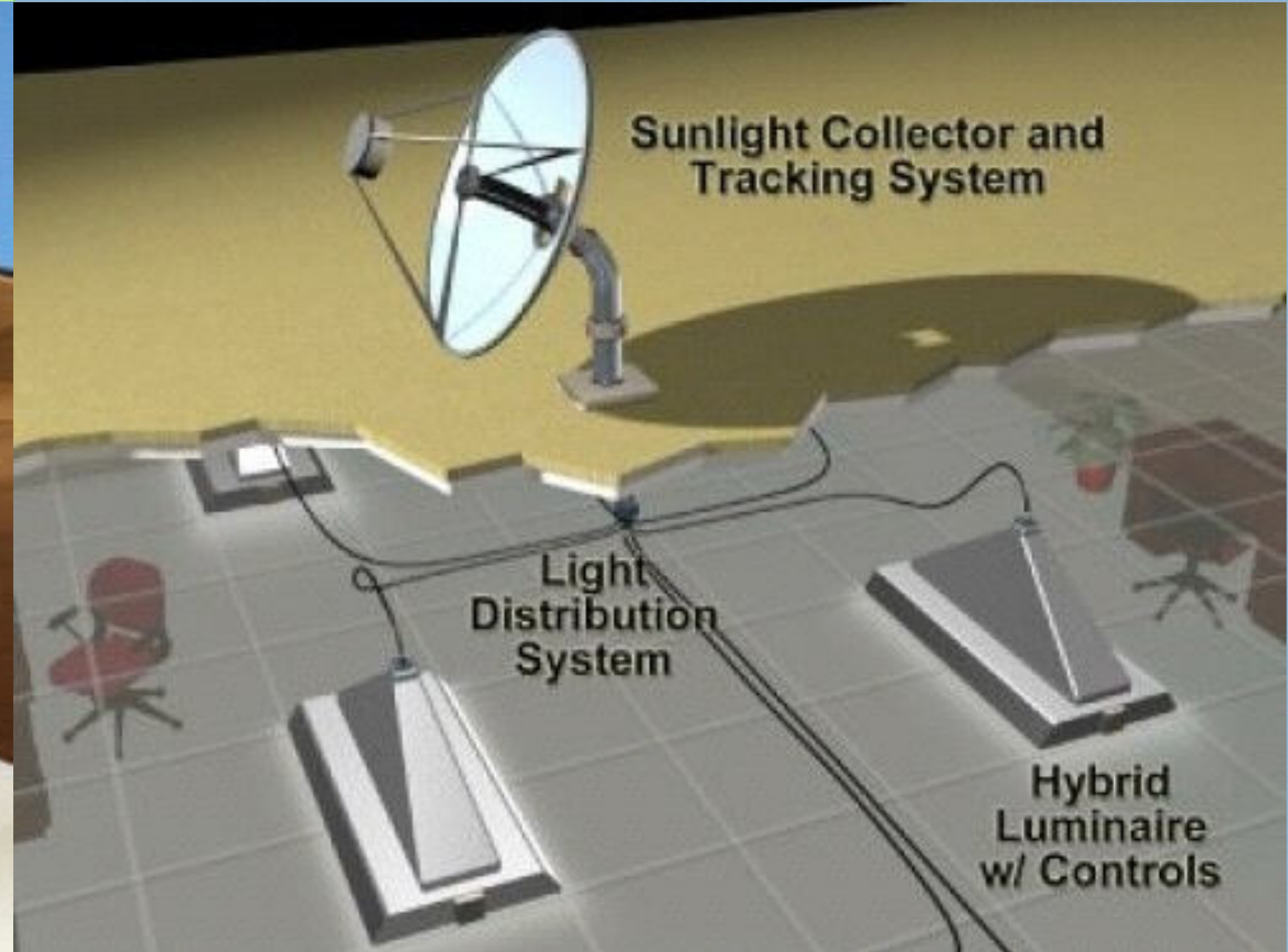
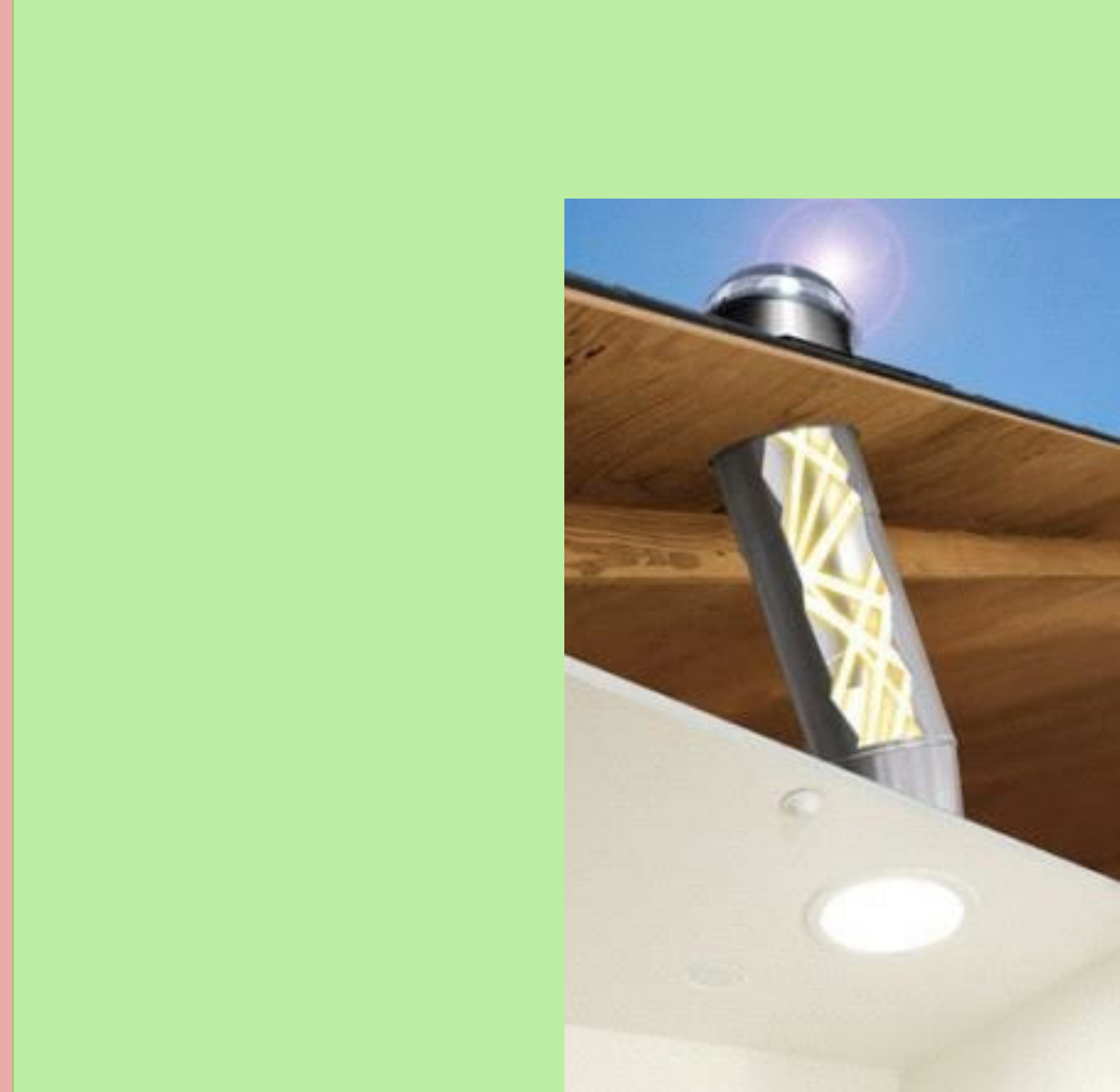

	Highlights	Remark
Solar Power	Already prove, prevalent	
Soil power	Green power but less power	interesting but have to prove locally
Gravity	Efficient, but small scale	how can I make it supply more power?
Liter of Light	Super sustainable and proven	can i exited and lit the whole building?
Wind power	Technically tough and seasonal	
Piezoelectricity	Good at selected scenario	
Hybrid Lighting	Power saver at higher initial cost	can i make it cheaper?
Human power	Dependable but laborious	it can always be a back up option
Thermo electric generator	scalable, less maintenance	potential option for power generation



Context

Rural need

As on 31 August 2013, a total of **32,227** villages of India are yet to be provided with electricity access, out of a total of 593,732 inhabited villages

The national average of households using electricity and solar energy for lighting is just **67.2** percent.

Scope of the project

The hybrid solution as such can be applied in both Rural and Urban scenario based on the power need and user interest on energy saving.

But if the solution is self sufficient and dependable off the grid, it will be more suitable for Rural areas of India from the statistics.

Sources of Lighting in India

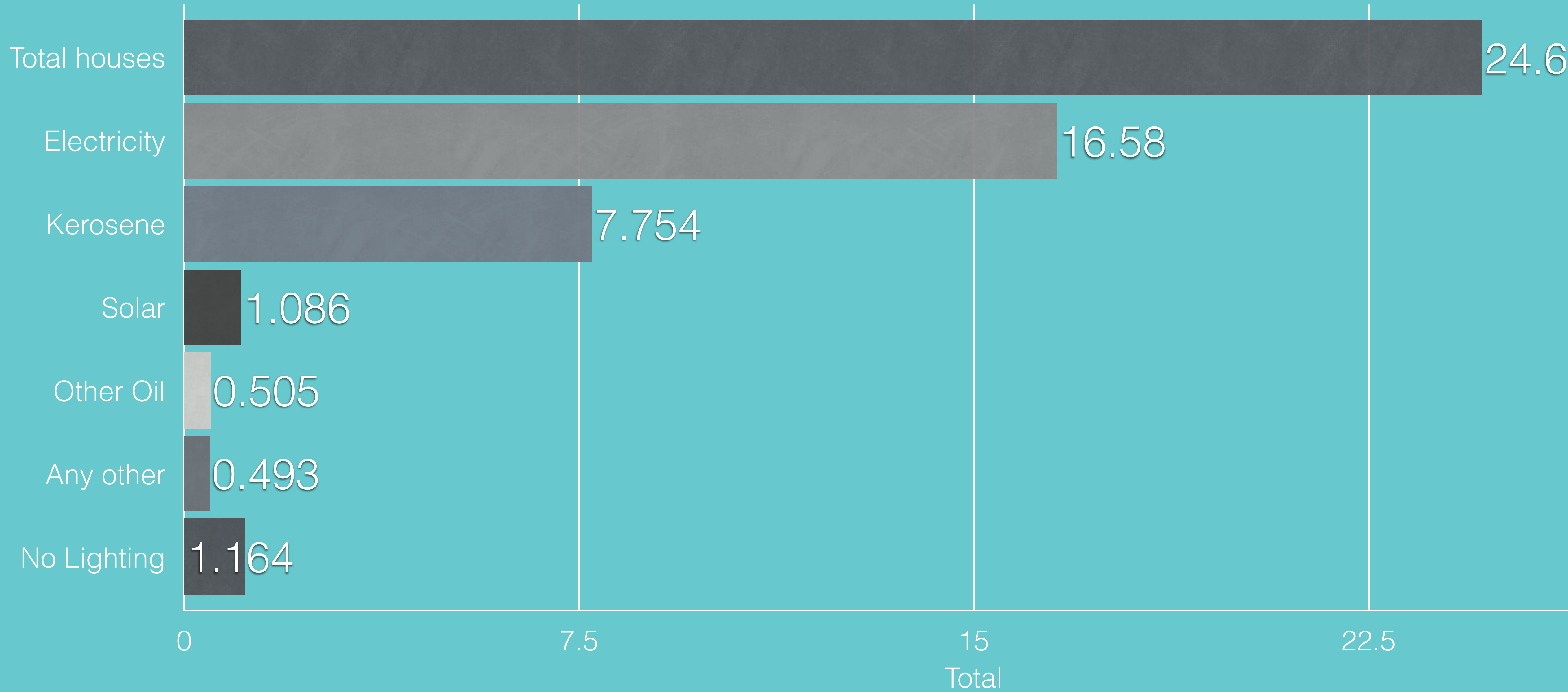

Sources of Lighting in India

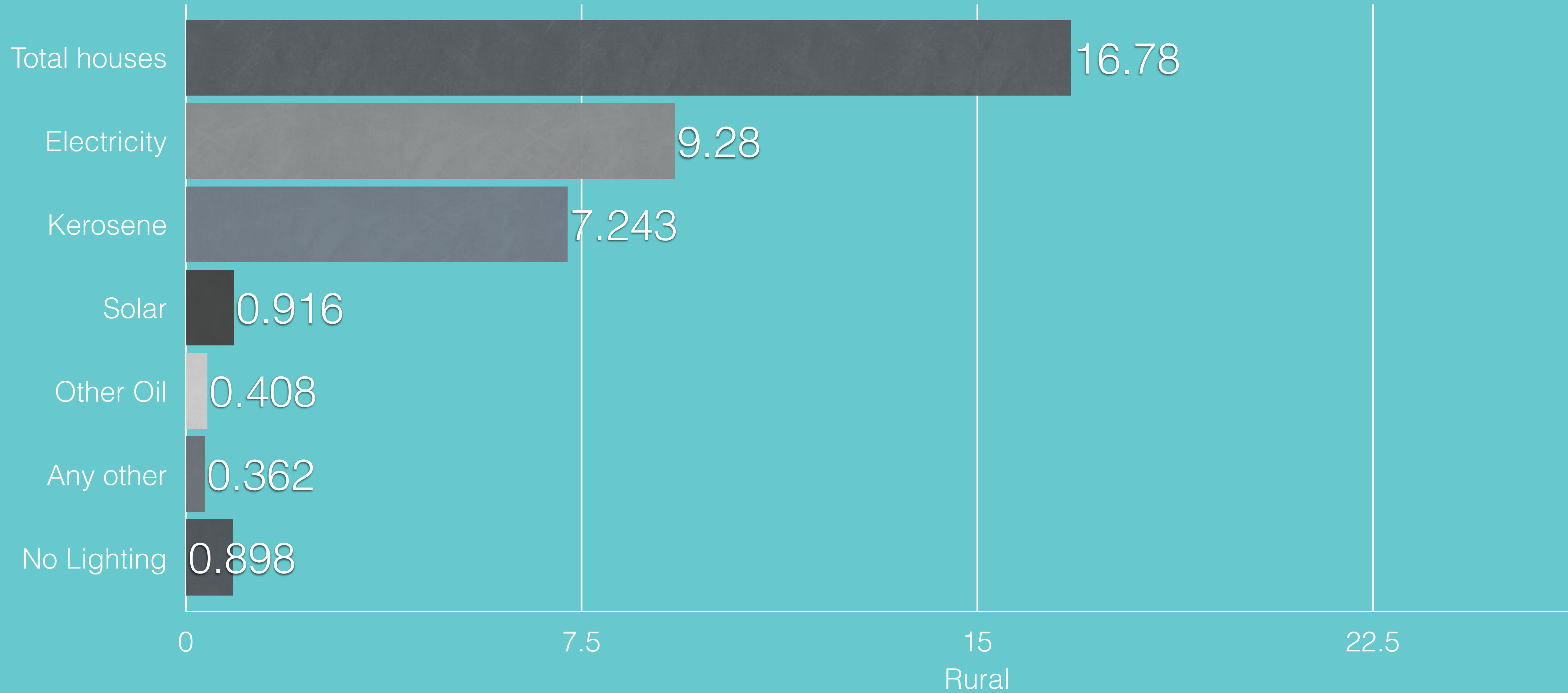

Household by source of power in every district of Tamilnadu:

Distribution of Households by source of lighting

State/ District Code	India ^a /State/ District	Distribution of households by source of lighting						
		Total No. of Households (Excluding institutional households)	Electricity	Kerosene	Solar energy	Other oil	Any other	No lighting
1	2	3	4	5	6	7	8	9
00	INDIA	24,66,92,667	67.3	31.4	0.4	0.2	0.2	0.5
33	TAMIL NADU	1,84,93,003	93.4	5.9	0.1	0.2	0.1	0.4
01	Thiruvallur	9,38,822	96.9	2.6	0.1	0.1	0.0	0.3
02	Chennai	11,06,567	98.1	0.8	0.0	0.0	0.0	0.1
03	Kancheepuram	9,93,809	96.7	2.7	0.1	0.1	0.1	0.3
04	Vellore	9,27,318	93.4	5.8	0.1	0.2	0.1	0.5
05	Tiruvannamalai	5,93,264	92.6	6.8	0.1	0.2	0.0	0.3
06	Viluppuram	8,04,343	93.1	6.4	0.1	0.1	0.0	0.3
07	Salem	9,18,899	90.9	8.1	0.1	0.2	0.1	0.6
08	Namakkal	4,77,757	92.3	6.8	0.1	0.2	0.1	0.6
09	Erode	6,58,734	90.4	8.4	0.1	0.2	0.1	0.8
10	The Nilgiris	1,98,922	90.6	8.7	0.1	0.2	0.1	0.3
11	Dindigul	5,63,172	88.8	10.0	0.1	0.3	0.0	0.7
12	Karur	2,87,848	92.0	7.3	0.0	0.1	0.0	0.5
13	Tiruchirappalli	7,00,852	93.0	6.4	0.0	0.1	0.0	0.4
14	Perambalur	1,49,401	90.9	8.4	0.0	0.3	0.0	0.4

Distribution of Households by source of lighting

State/ District Code	India ^a /State/ District	Distribution of households by source of lighting						
		Total No. of Households (Excluding institutional households)	Electricity	Kerosene	Solar energy	Other oil	Any other	No lighting
1	2	3	4	5	6	7	8	9
15	Ariyalur	1,98,106	89.6	9.7	0.0	0.2	0.0	0.4
16	Cuddalore	6,37,422	93.9	5.6	0.0	0.1	0.0	0.3
17	Nagapattinam	4,12,656	92.6	6.9	0.0	0.1	0.0	0.3
18	Thiruvarur	3,27,971	92.4	7.1	0.0	0.1	0.0	0.3
19	Thanjavur	6,05,074	91.8	7.6	0.0	0.1	0.0	0.4
20	Pudukkottai	3,90,628	90.7	8.5	0.1	0.1	0.0	0.4
21	Sivaganga	3,41,960	91.9	7.1	0.1	0.2	0.0	0.7
22	Madurai	7,97,939	94.5	4.8	0.0	0.1	0.0	0.5
23	Theni	3,40,965	91.6	7.4	0.2	0.2	0.1	0.5
24	Virudhunagar	5,40,132	93.7	5.6	0.0	0.1	0.1	0.5
25	Ramanathapuram	3,28,955	88.6	10.3	0.2	0.2	0.1	0.7
26	Thoothukkudi	4,64,324	94.3	5.0	0.0	0.1	0.1	0.5
27	Tirunelveli	8,20,327	95.0	4.2	0.0	0.1	0.1	0.6
28	Kanniyakumari	4,89,201	95.2	4.0	0.2	0.2	0.0	0.4
29	Dharmapuri	3,80,924	88.7	10.3	0.1	0.3	0.1	0.6
30	Krishnagiri	4,50,062	90.9	8.1	0.1	0.2	0.1	0.6
31	Coimbatore	9,45,943	94.8	4.7	0.1	0.1	0.0	0.3
32	Tiruppur	7,00,706	93.5	5.7	0.1	0.2	0.0	0.5

Household by source of power in Tamilnadu:

Households by main source of lighting						
Total number of households	1,84,93,003	95,63,899	89,29,104	100.0	100.0	100.0
Electricity	1,72,65,059	86,83,426	85,81,633	93.4	90.8	96.1
Kerosene	10,95,489	7,91,493	3,03,996	5.9	8.3	3.4
Solar	13,669	8,720	4,949	0.1	0.1	0.1
Other oil	27,853	19,254	8,599	0.2	0.2	0.1
Any other	8,971	5,294	3,677	0.0	0.1	0.0
No lighting	81,962	55,712	26,250	0.4	0.6	0.3

Power production cost of different sources

Source of Fuel	Generation Cost per kWh (Rs.)	Transmission Infrastructure Cost Per Km for a load of 100kW	Other Maintenance costs/distribution on infrastructure etc (per kWh)	Total Cost of Generation per kWh per km	Total Cost of Generation per kWh at a 5 Km distance from Grid/33KVA line	Total Cost of Generation per kWh at a 10 Km distance from Grid/33KVA line	Total Cost of Generation per kWh at a 15 Km distance from Grid/33KVA line	Life of the Unit
Coal	Rs. 2.00	Rs. 1	Rs. 0.50	Rs. 3.50	Rs. 7.50	Rs. 12.50	Rs. 17.50	30 years
Solar PV	Rs. 9.00	Nil	Rs. 0.20	Rs. 9.20	Rs. 9.20	Rs. 9.20	Rs. 9.20	25 years
Biomass	Rs. 4.25	Nil	Rs. 0.50	Rs. 4.75	Rs. 4.75	Rs. 4.75	Rs. 4.75	15 years
Micro Hydro	Rs. 4.20	Nil	Rs. 0.30	Rs. 4.50	Rs. 4.50	Rs. 4.50	Rs. 4.50	25 years
Wind	Rs. 4.50	Nil	Rs. 0.30	Rs. 4.80	Rs. 4.80	Rs. 4.80	Rs. 4.80	25 years

Power Shortage across India

36% of the total households receive electricity supply for 20 to 24 hours, while 30% of the households get less than 12 hours of electricity supply with **23% of the households getting less than 8 hours of supply** and the balance of **11% had either not supply or were getting just less than 4 hours of supply every day.**

Questionnaire

- ▶ What is the duration of power cut in their region?
- ▶ What is the first source of light after the power off?
- ▶ What are the alternate source of light they use to face the power cut off?
- ▶ Is it rechargeable one, if so how much power and time needed for recharge?
- ▶ Is it self sustaining or require human power for operation other than switching it ON?
- ▶ How long your devices can provide light?
- ▶ What is the cost for your source of energy?
- ▶ What is the amount spent every month on electricity?
- ▶ What are their activities during power off?



- People buy **generator** as backup for UPS
 - **Rent** CFL lamps time to time

Will be great, if we can produce power without much effort

- *we plan our activities according to the power*
 - **mobile** is the first source of light for most people when power goes off
 - **LED bulbs** are trending
 - Increasing **UPS** culture
 - Solar is **not affordable**
 - Kerosene lamps are always there for help
 - **Power theft**
 - We would like to go for our **own power** instead of depending the govt.



Insights from User Data

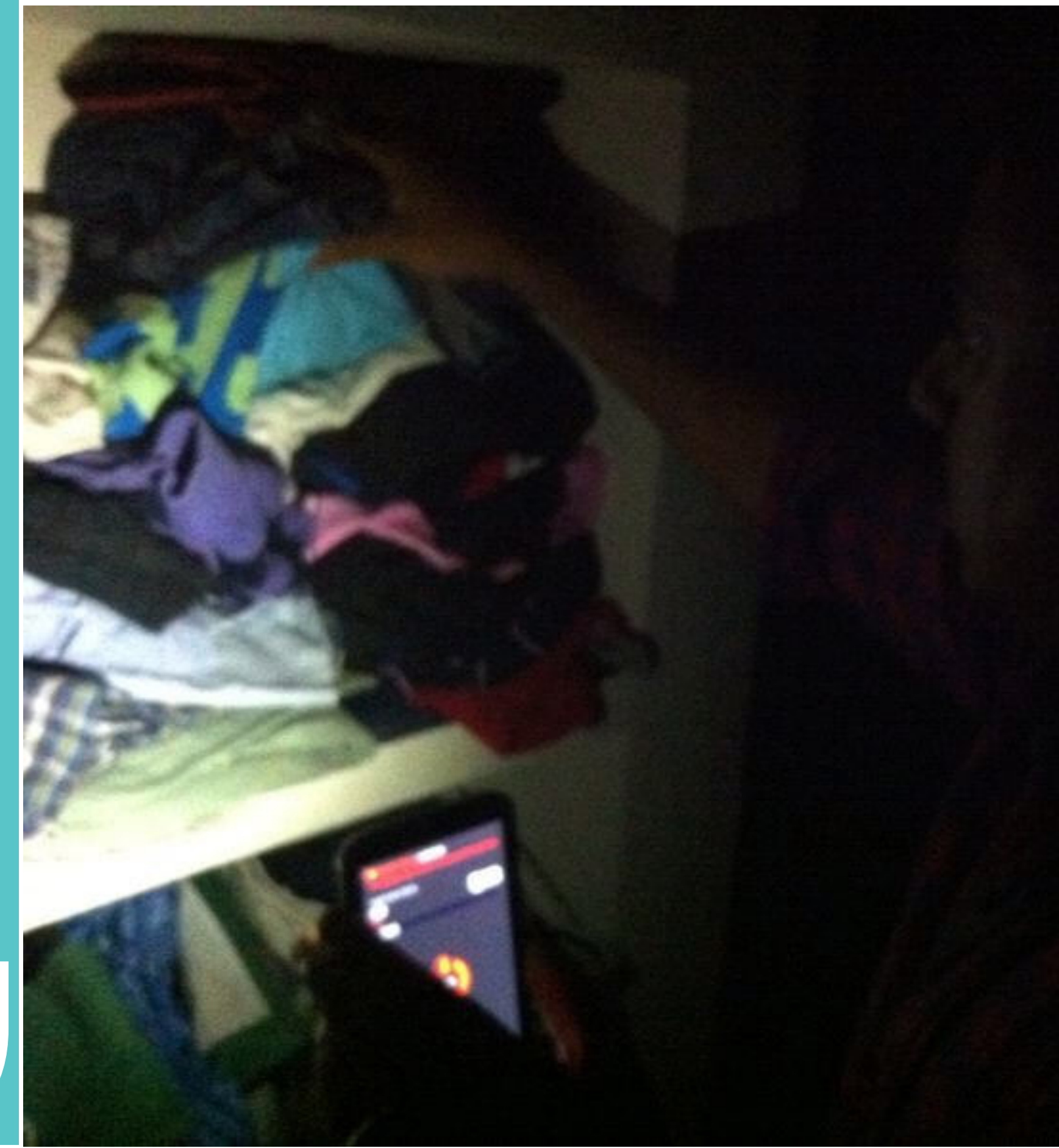

Experiment

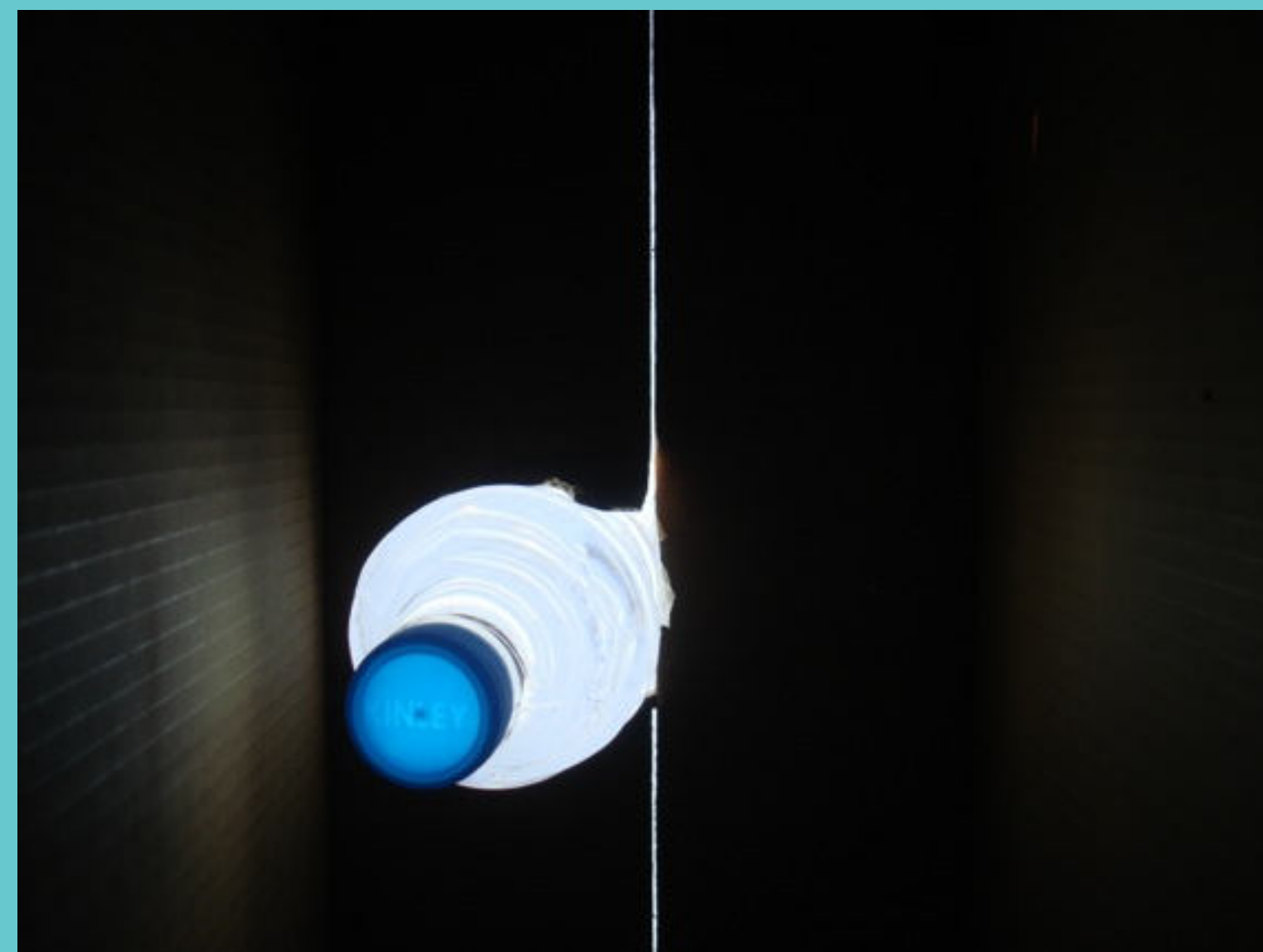
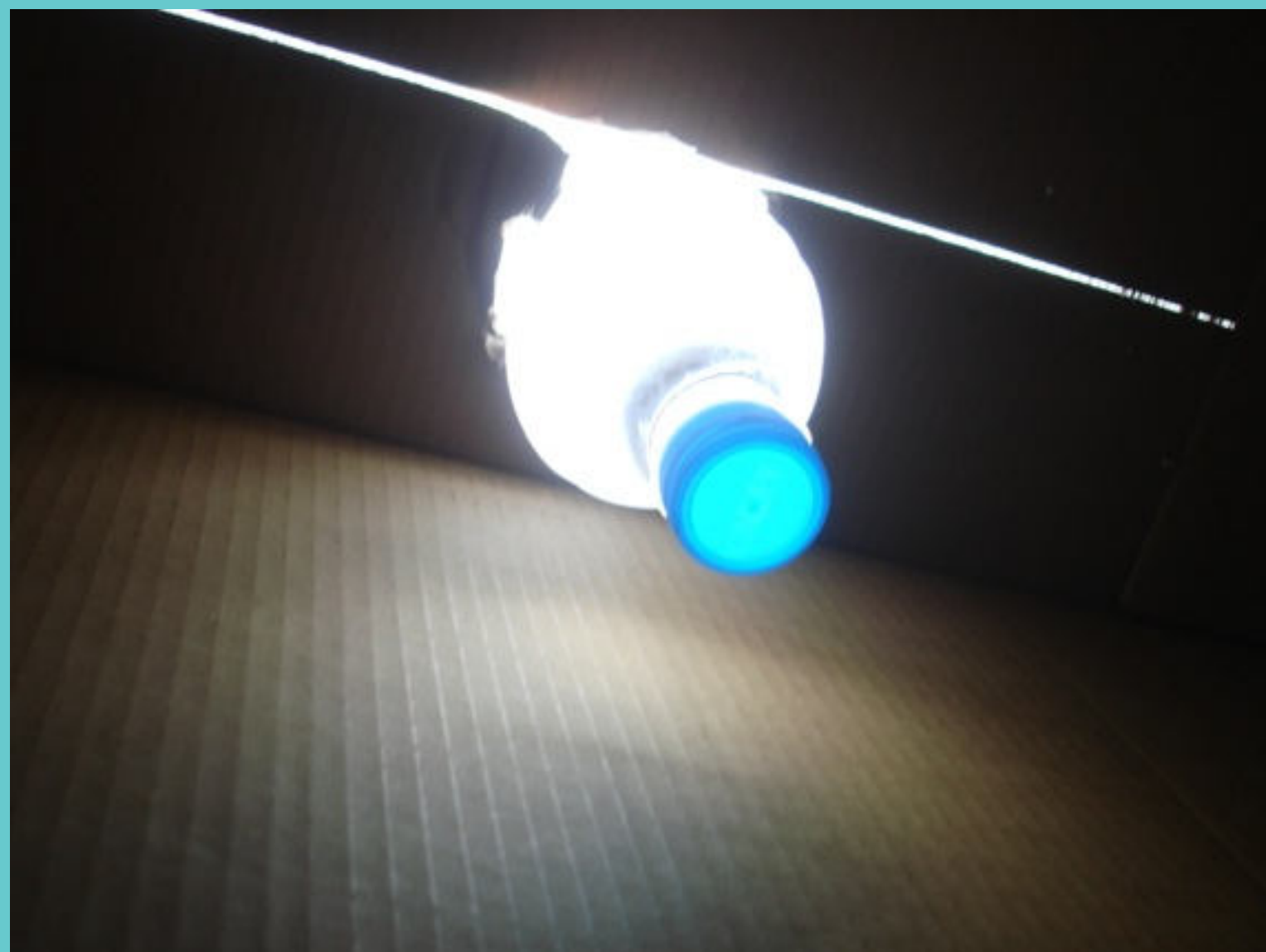

Experiment



Design Brief

To design a hybrid lighting solution using the Solar or Thermo Electric Generator or gravity or human powered alternate technology (to be fixed after experiments) to address the need of power crisis in India considering off the grid solutions.

Design should be self sustainable, clean and locally viable. It should produce value even when it is connected with the grid

Mind Map:

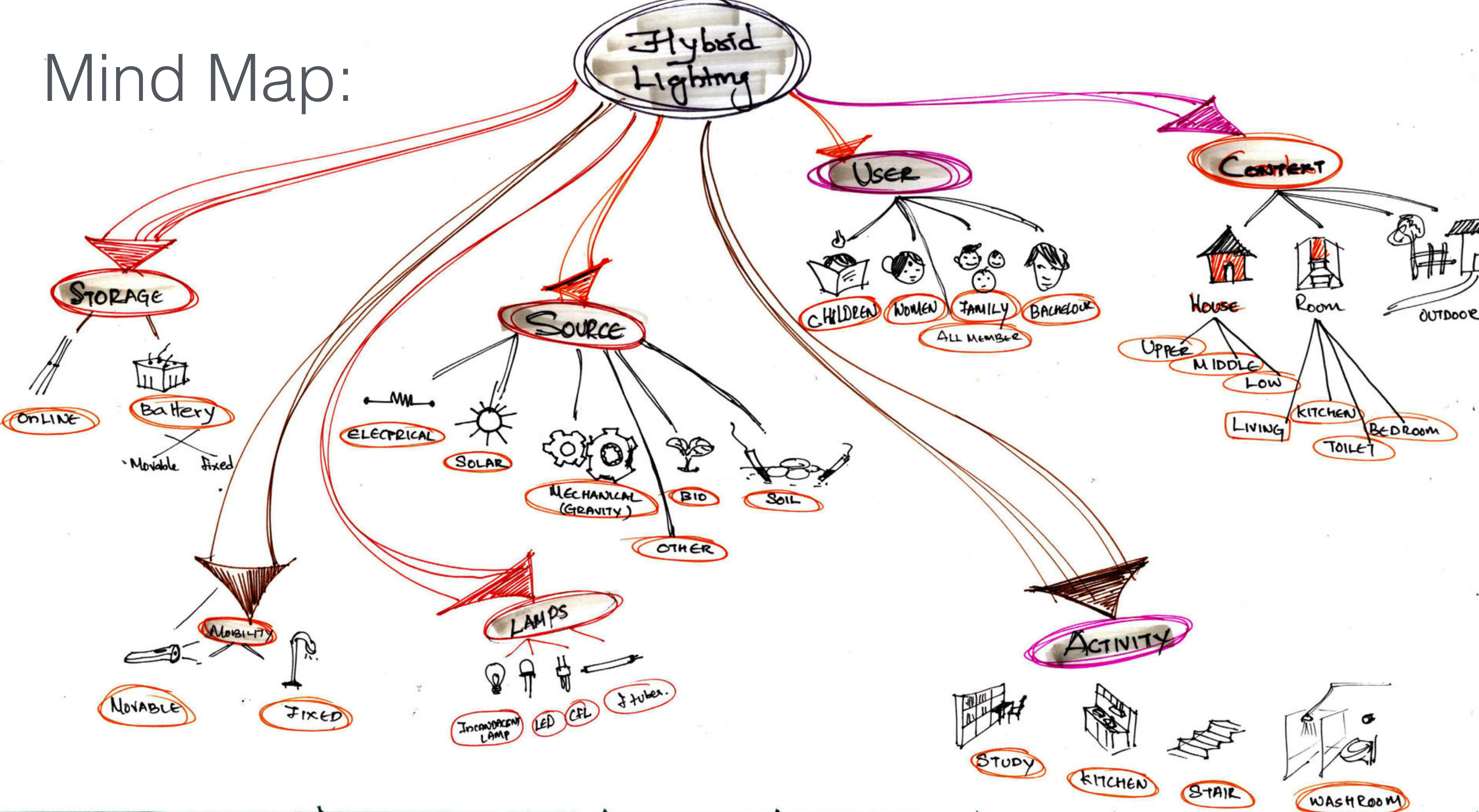

Ideation:

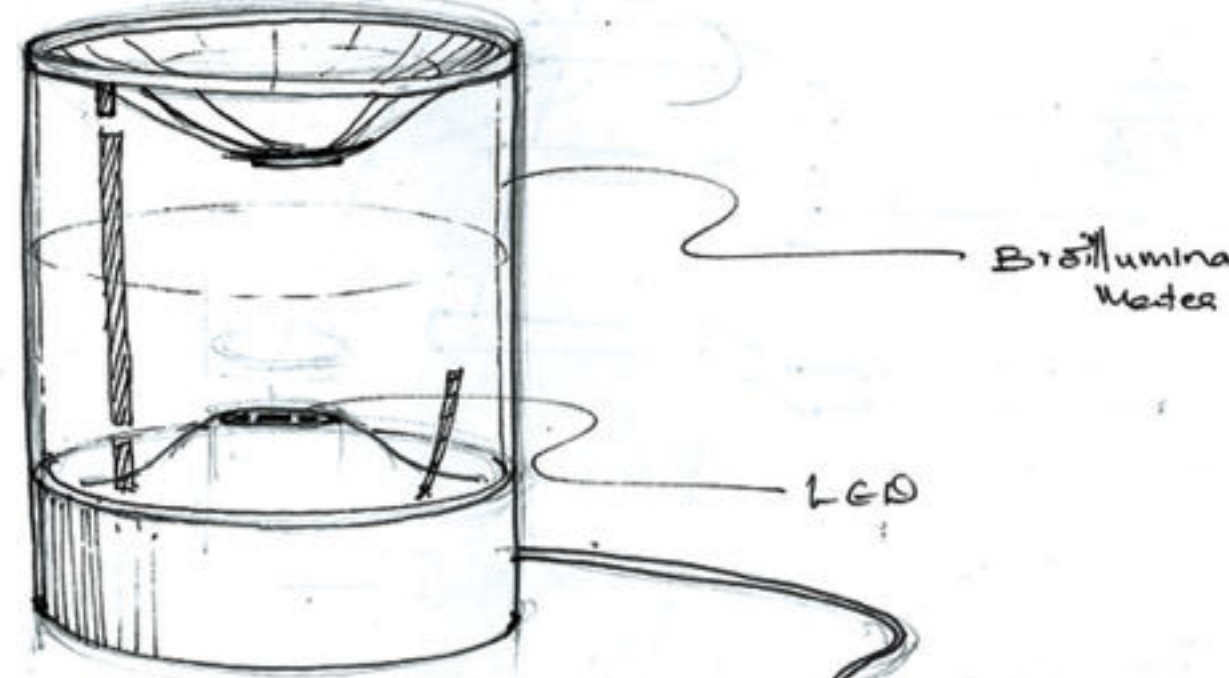
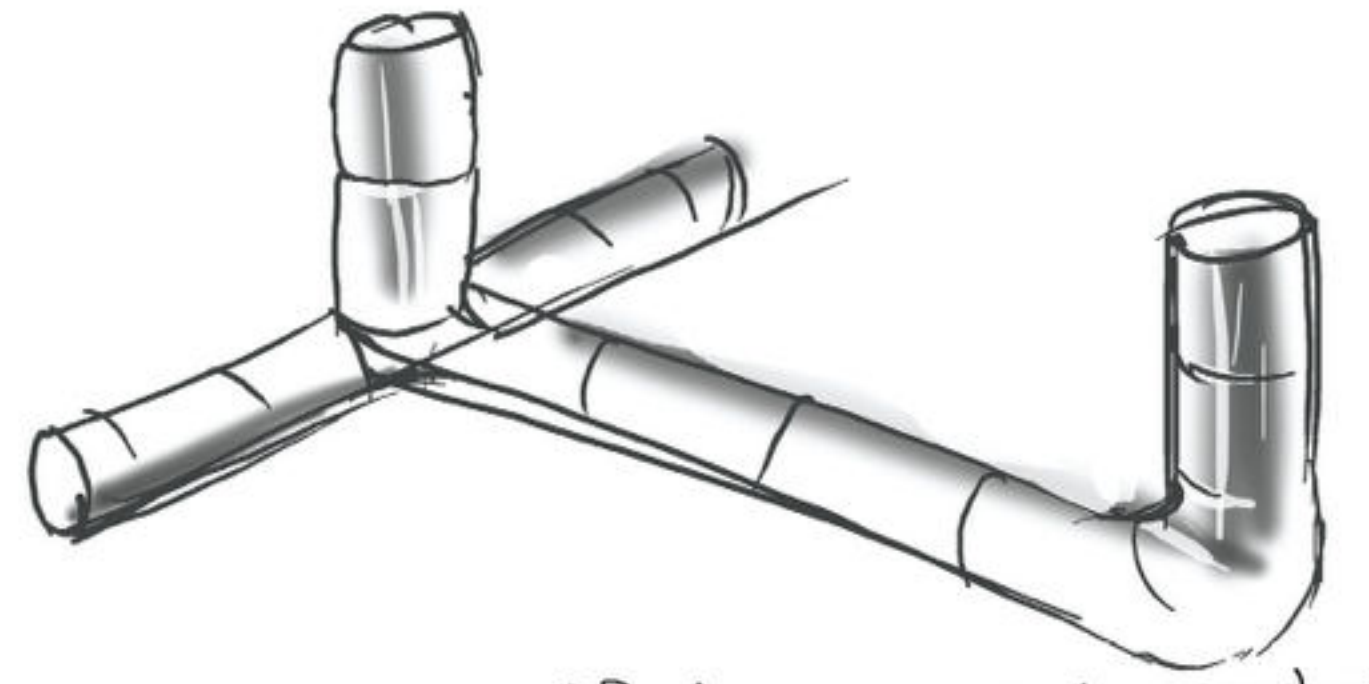
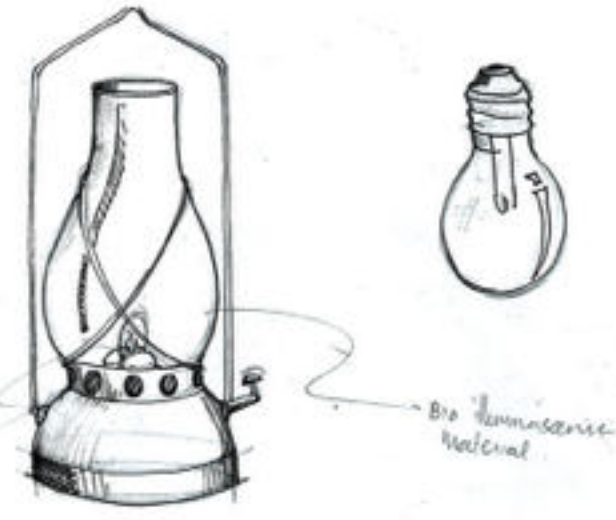
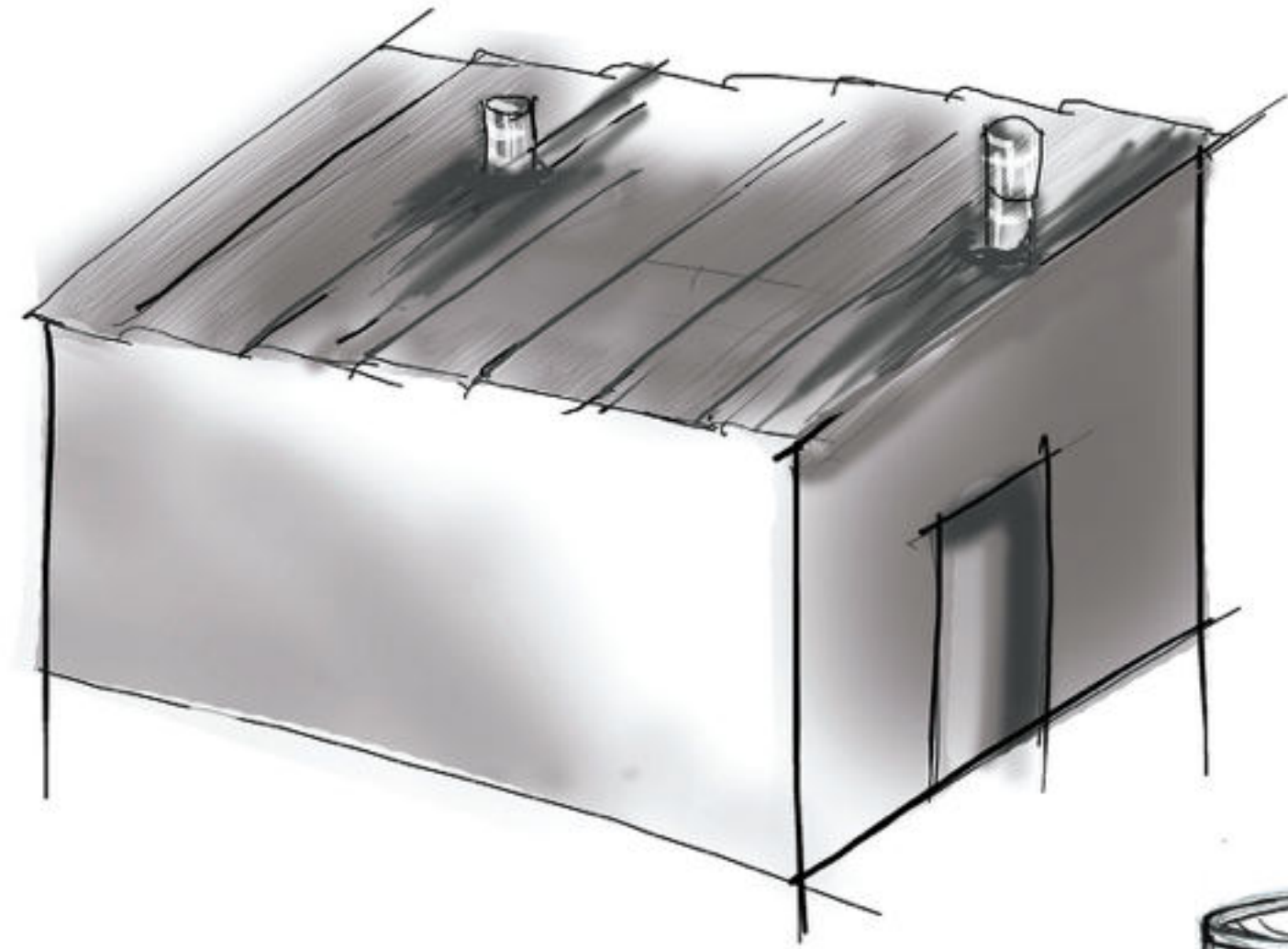

• Prolonged illuminance or reflection of light from the source of artificial light (led, etc...)

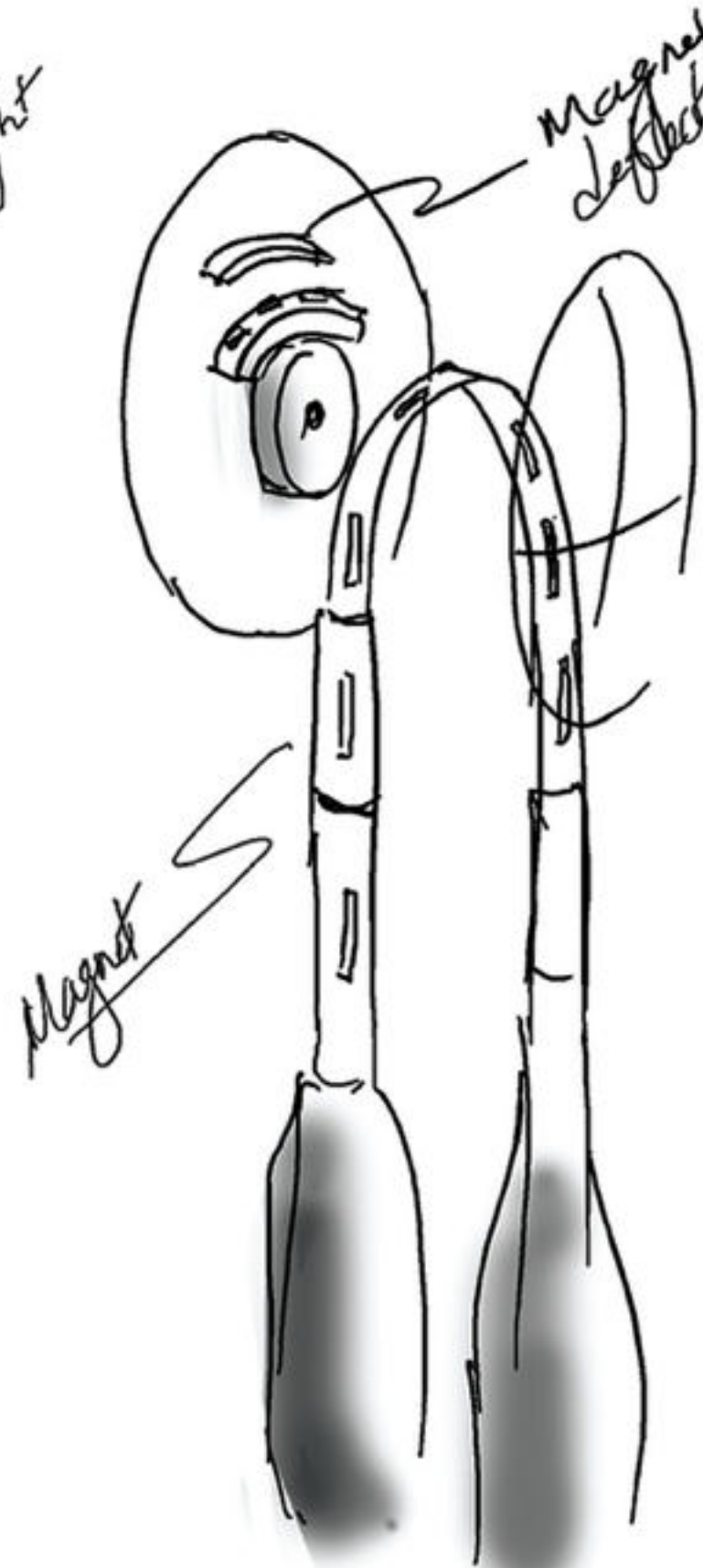
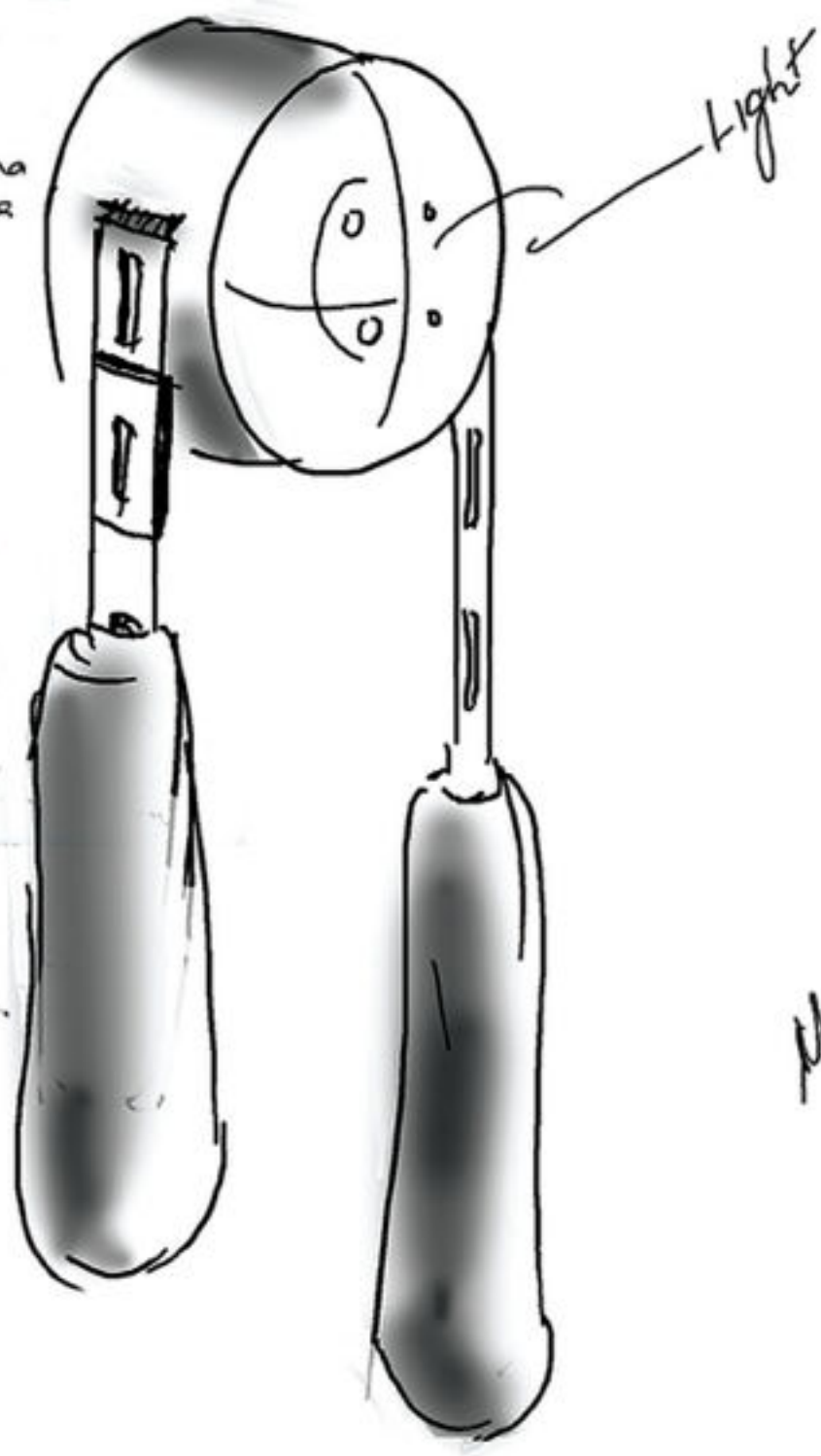
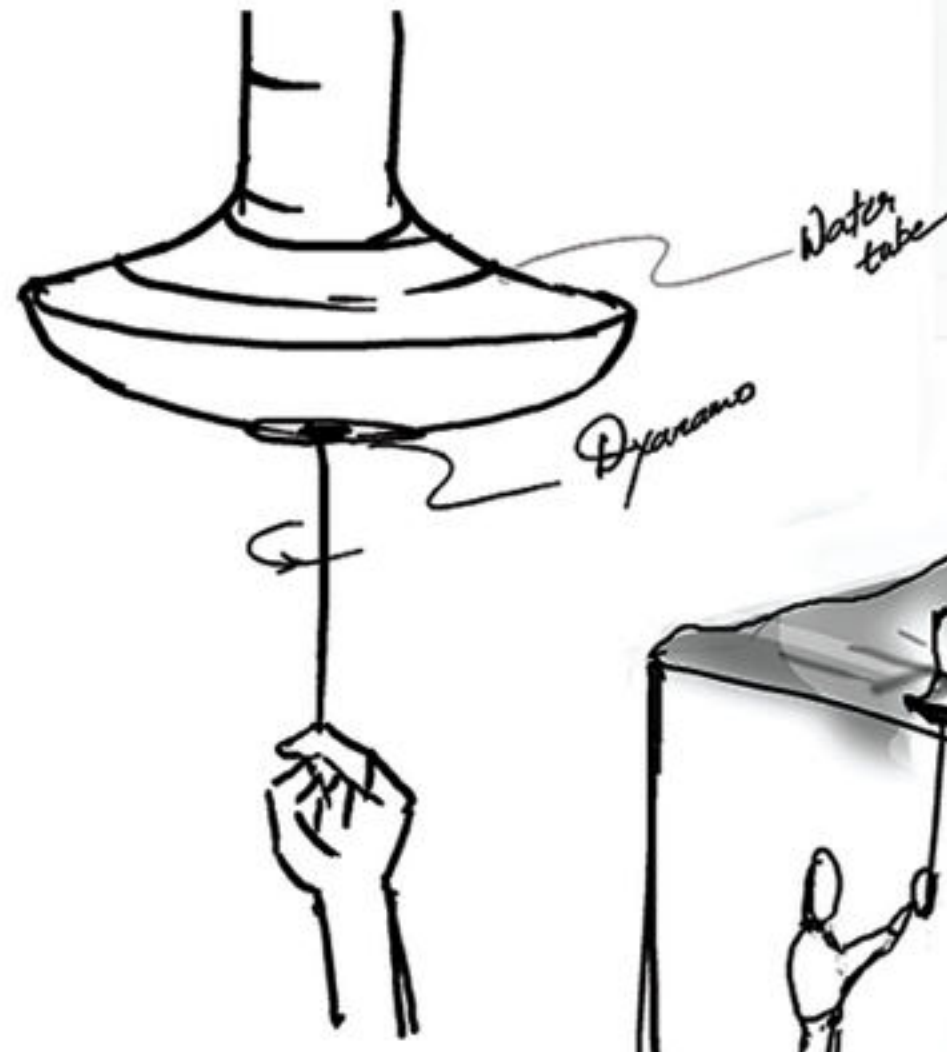

Ideation:

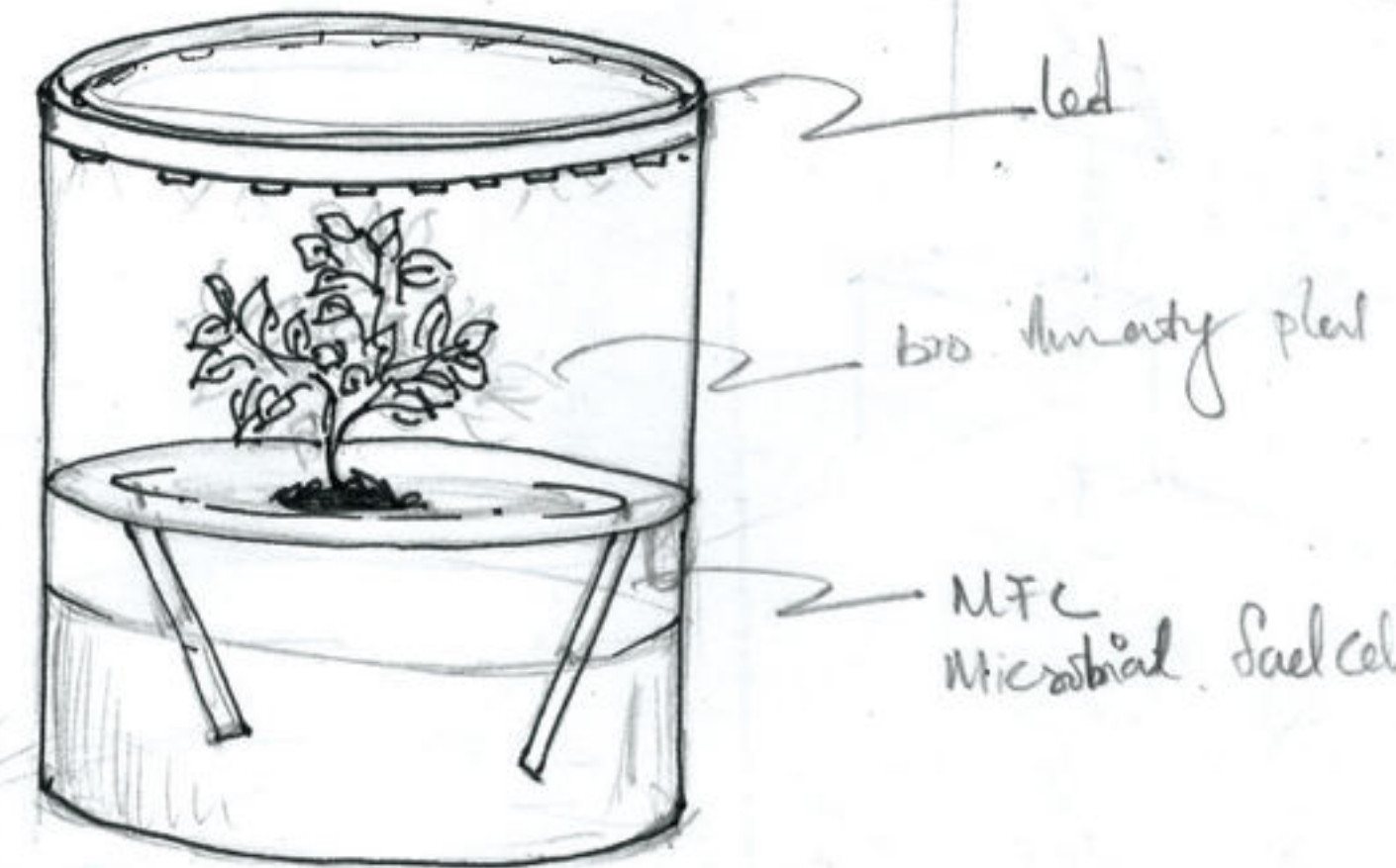
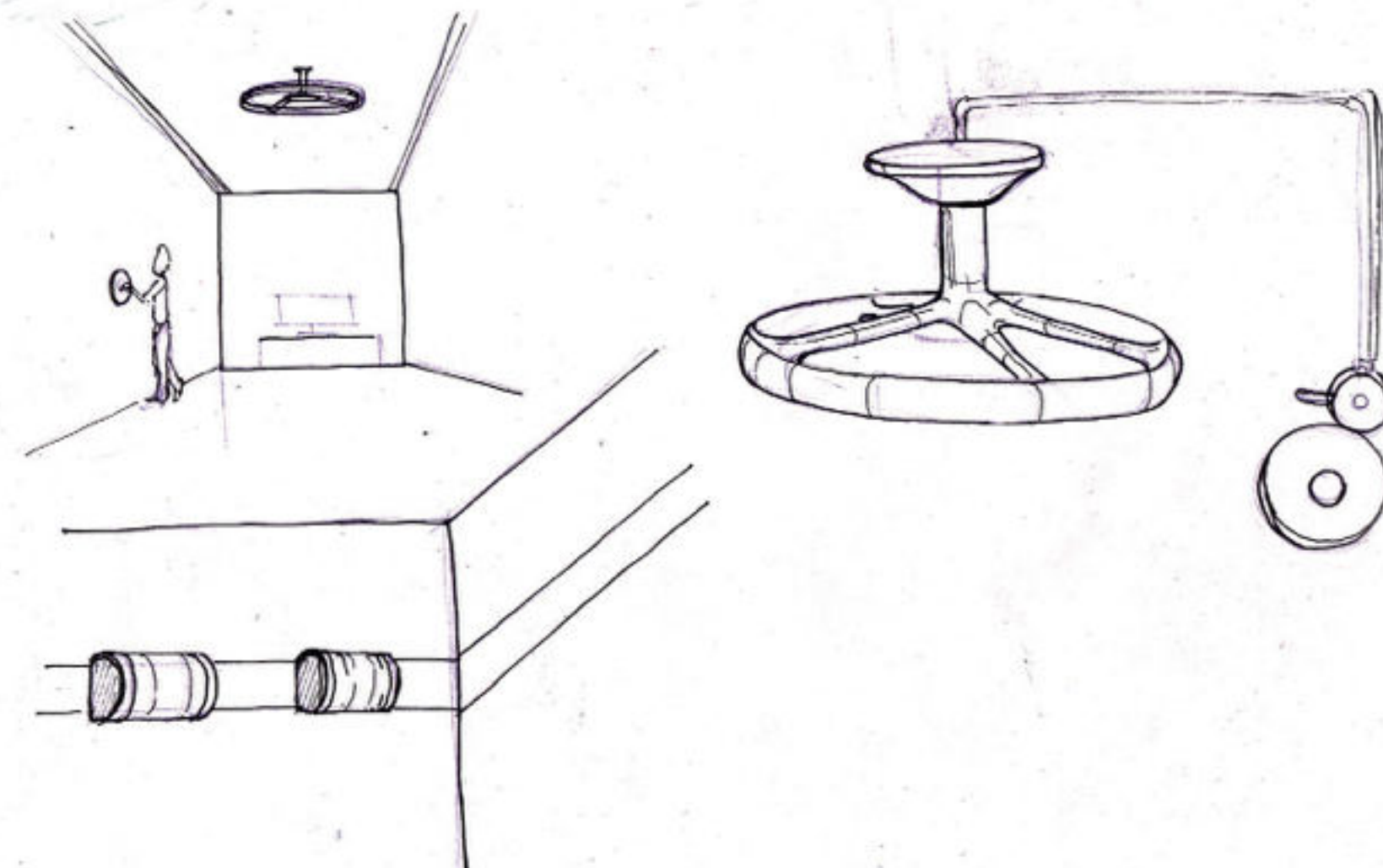
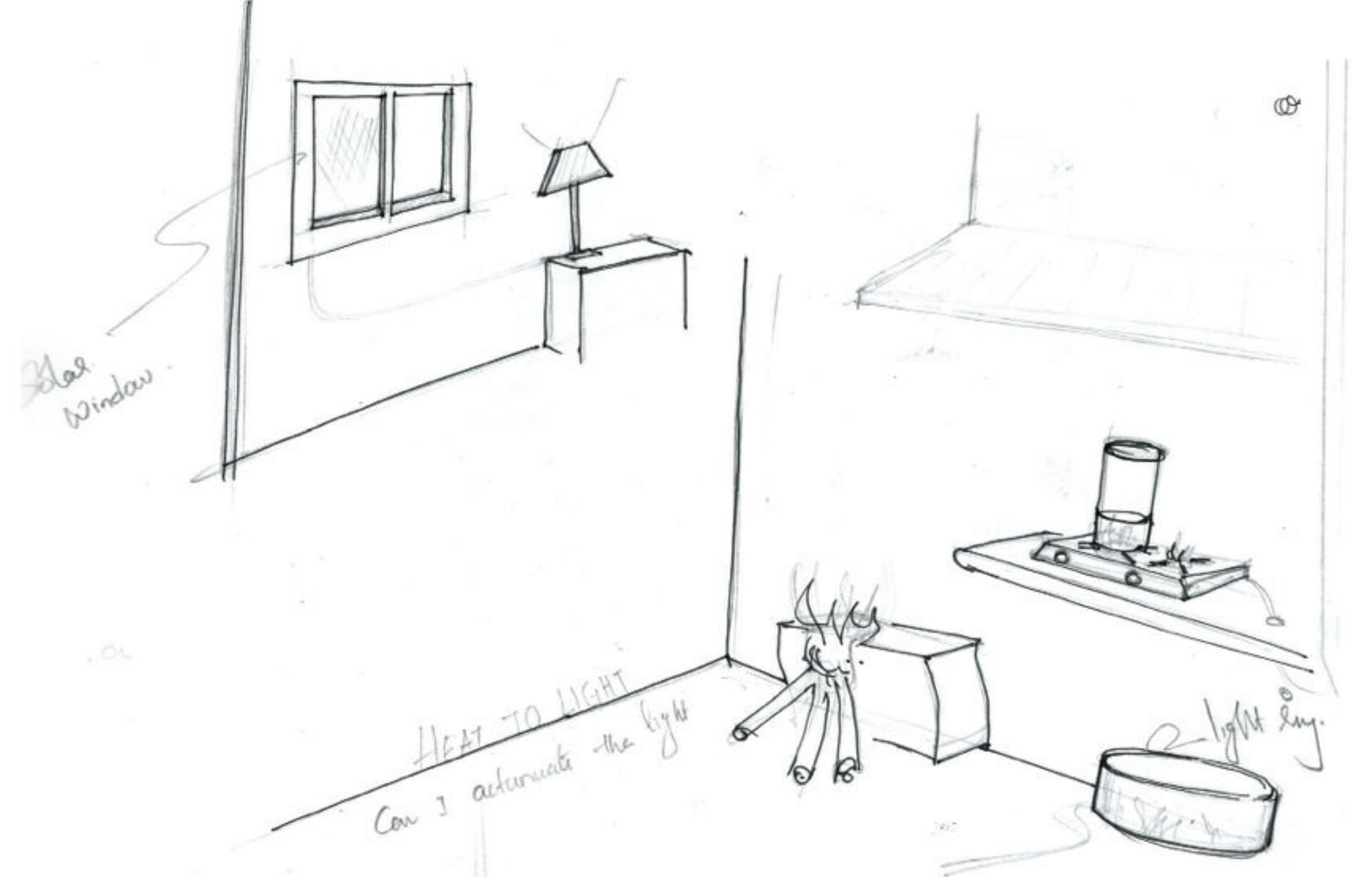
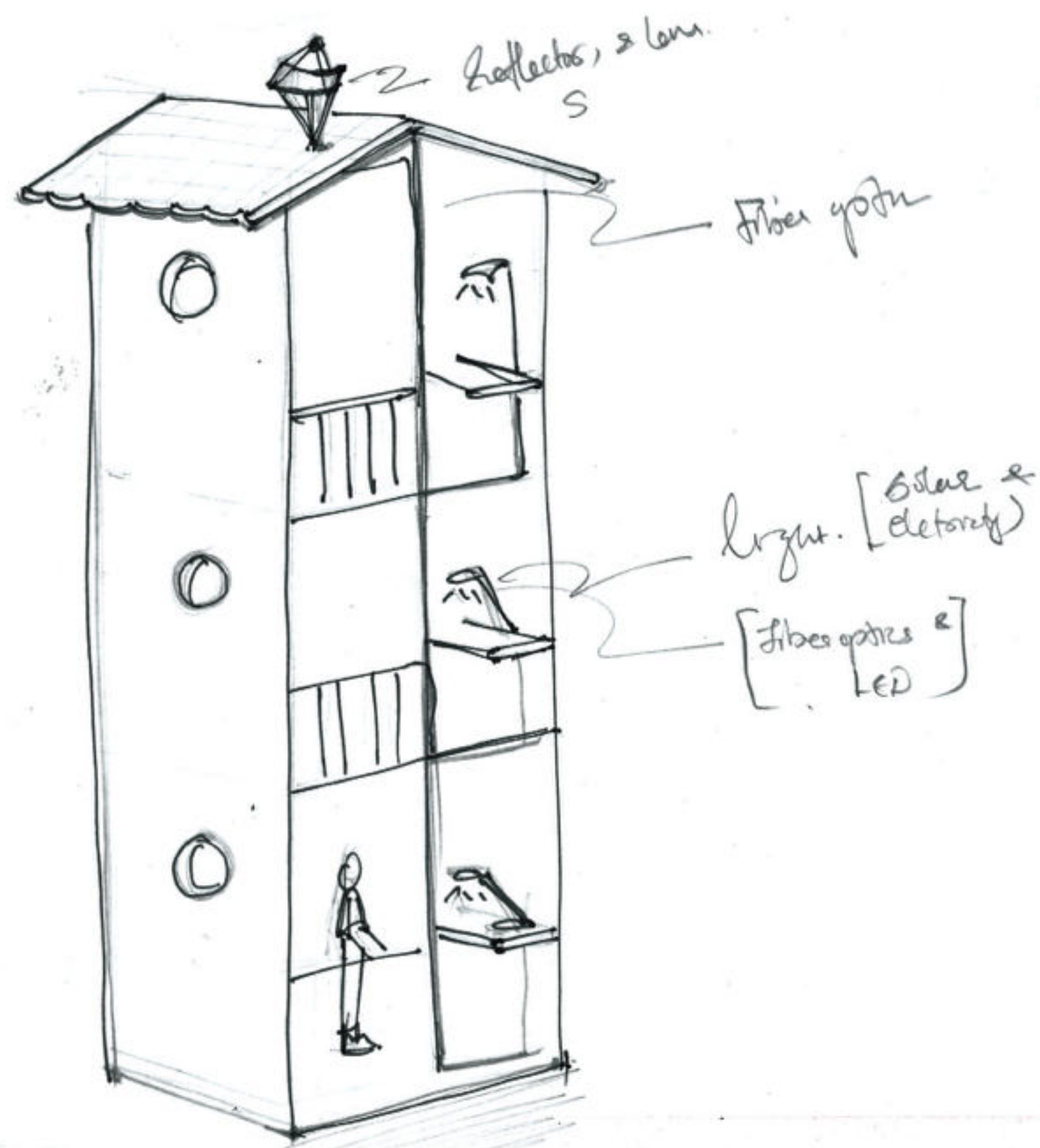

Ideation:

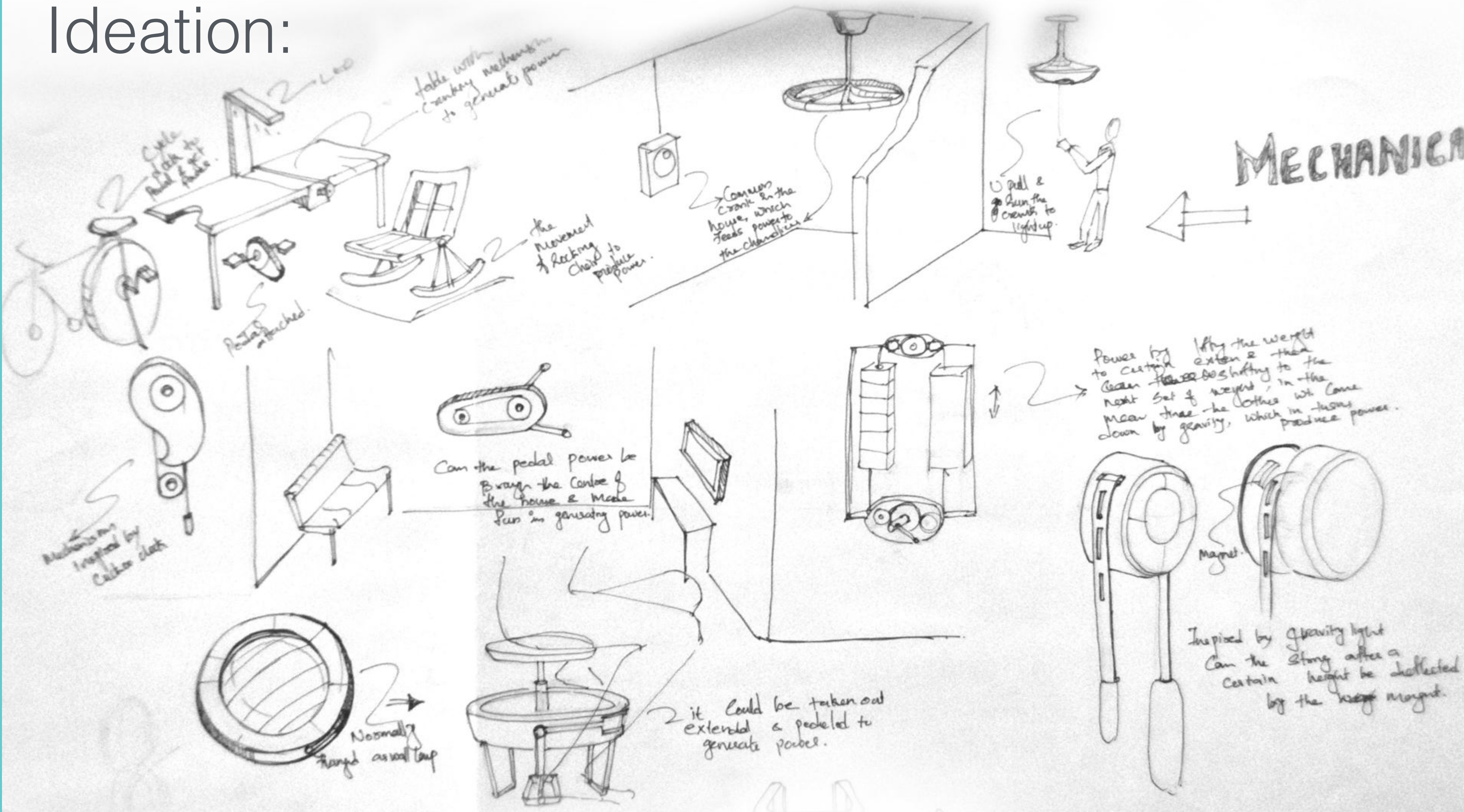

Design Directions

From consolidated chart

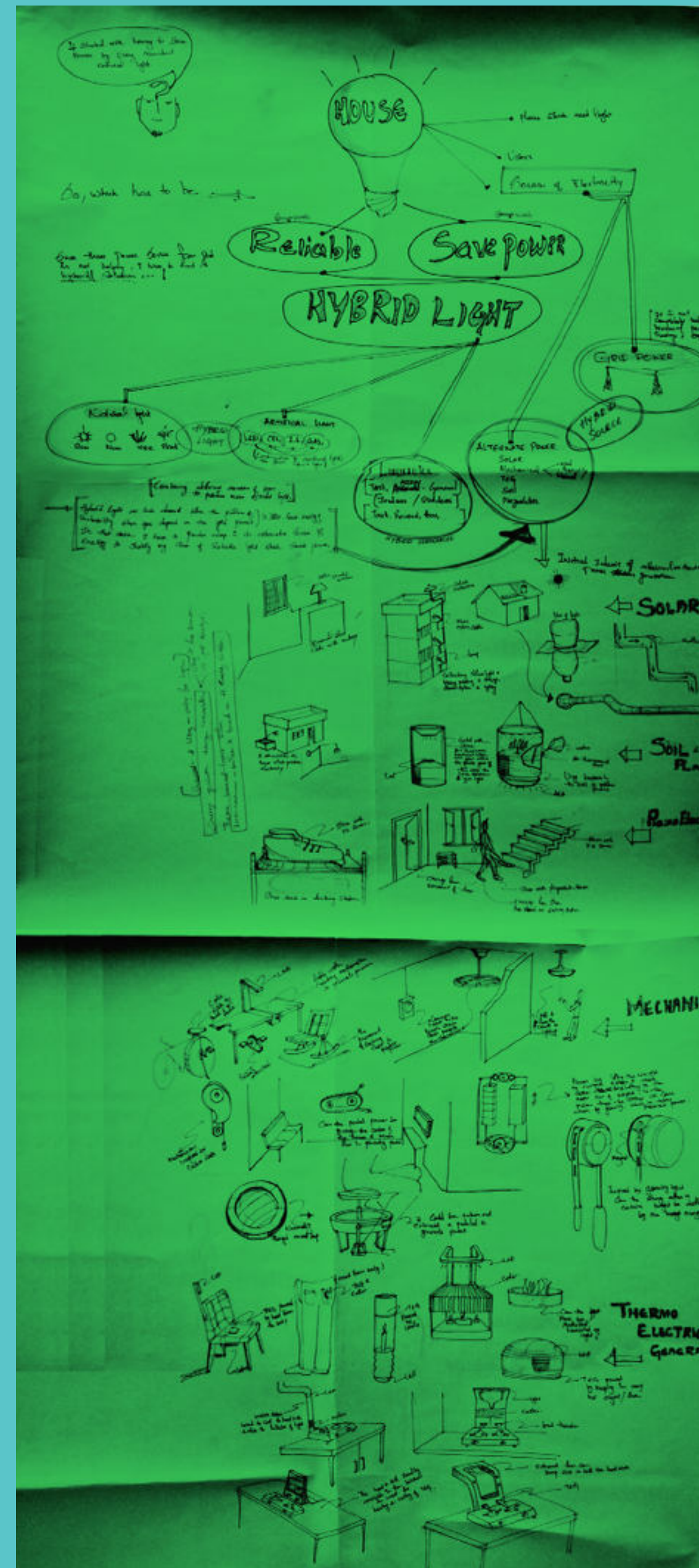

1. Luminary for hybrid light:

Design a Luminary which will support both conventional and unconventional light sources. which should be adaptable to existing lamps and increase the efficiency of lighting.

2. Hybrid energy source which support lighting:

Design a device which helps in producing power using non conventional methods, with the regular activities in the house and support lighting with less effort. The device also should support the existing grid operated lighting. The main objective is to enhance the reliability and efficiency of lighting by saving cost and power.

3. Design a alternative energy source:

Design a device which will support power production using the non conventional method and help as additional source of power, by utilising the regular activities inside the house.

Literature Study

Phase II

Market study

User Study

Thermo Electric Generator

So far the design brief evolved from
Increasing the efficiency of lighting to
Power generation to
Localized scenario based solution.



Also from the analysis of people and the activities they prefer to do, it implied that power generation with less effort is an important factor to consider. Hybrid power generation is considered in terms of increased reliability and efficiency in lighting, than a grid connected system. By all these insights, analysis and user feedback. Designing a hybrid energy source and using Thermo electric generator (TEG) for lighting, seems to be the most suitable choice (brief 2).

Benefits of using a TEG:

(Insights from both Wood, gas & diesel stove based experiments)

- It does not require extra energy from the stove.
- The TE generator is incorporated into the cook stove and requires no electrical link with the outside world, unlike solar panels.
- It is silent in operation as it involves no moving parts.
- The maintenance is very light, nothing moves, everything is inside the house, only the battery needs to be changed when it is done for.
- The TE generator works when the stove is on, day and night in good or in rainy weather (monsoon period) unlike solar panels.
- The battery does not need to be oversized as each use of the stove recharges the battery unlike a solar system.
- Forced cooling using either air or water (or other coolants) is efficient, but it is parasitic on the generated power and/or bulky and inconvenient.
- Middle-class users in regions with unreliable grids might serve as customers at least at the initial market stages.

Market Study

The DW-ST-15W Wood Burning Stove Thermoelectric Generator can be placed on the top of a heat source such as a wood stove to charge a battery, power a 12V DC device,



These Russian stoves are solid fuel heating and cooking stoves with a built-in thermal electric generator which transforms the thermal energy of burned fuel into electric power



This Seiko watch when it is worn on the wrist, the watch absorbs body heat from the back case and dissipates it from the front of the watch to generate power with its thermal converter.

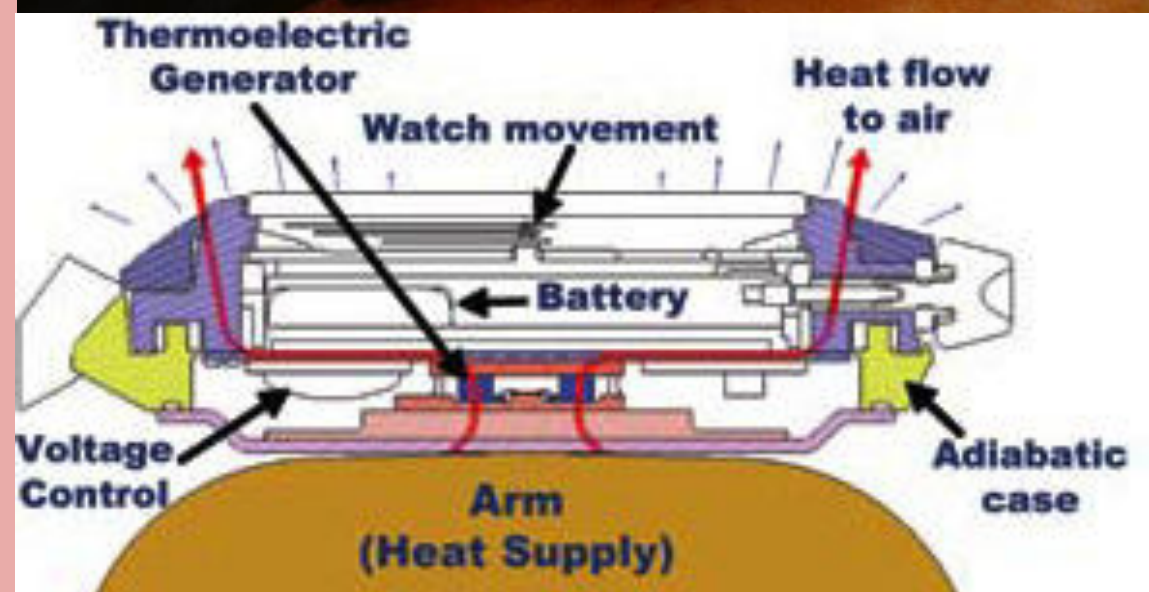

The Power pot is a pot that you fill with water and place directly onto any heat source. This may be a campfire or a propane or alcohol stove.



Future of TEG



The collage consists of three main sections:

- Screen printing technique:** Shows a process with labels: Squeegee, Paste, Mask, and Deposition.
- Wearable thermoelectric generator:** Shows a person's hand wearing a small, flexible TEG device. Labels include Bi_2Te_3 , fabric, and Sb_2Te_3 . The KAIST logo is present.
- Power generation on human body:** Shows a person's wrist with a TEG device connected to a multimeter. Labels include "Electricity" and "Body heat". The NIT logo is present.



Experiment

Components used for the experiment and their Specification

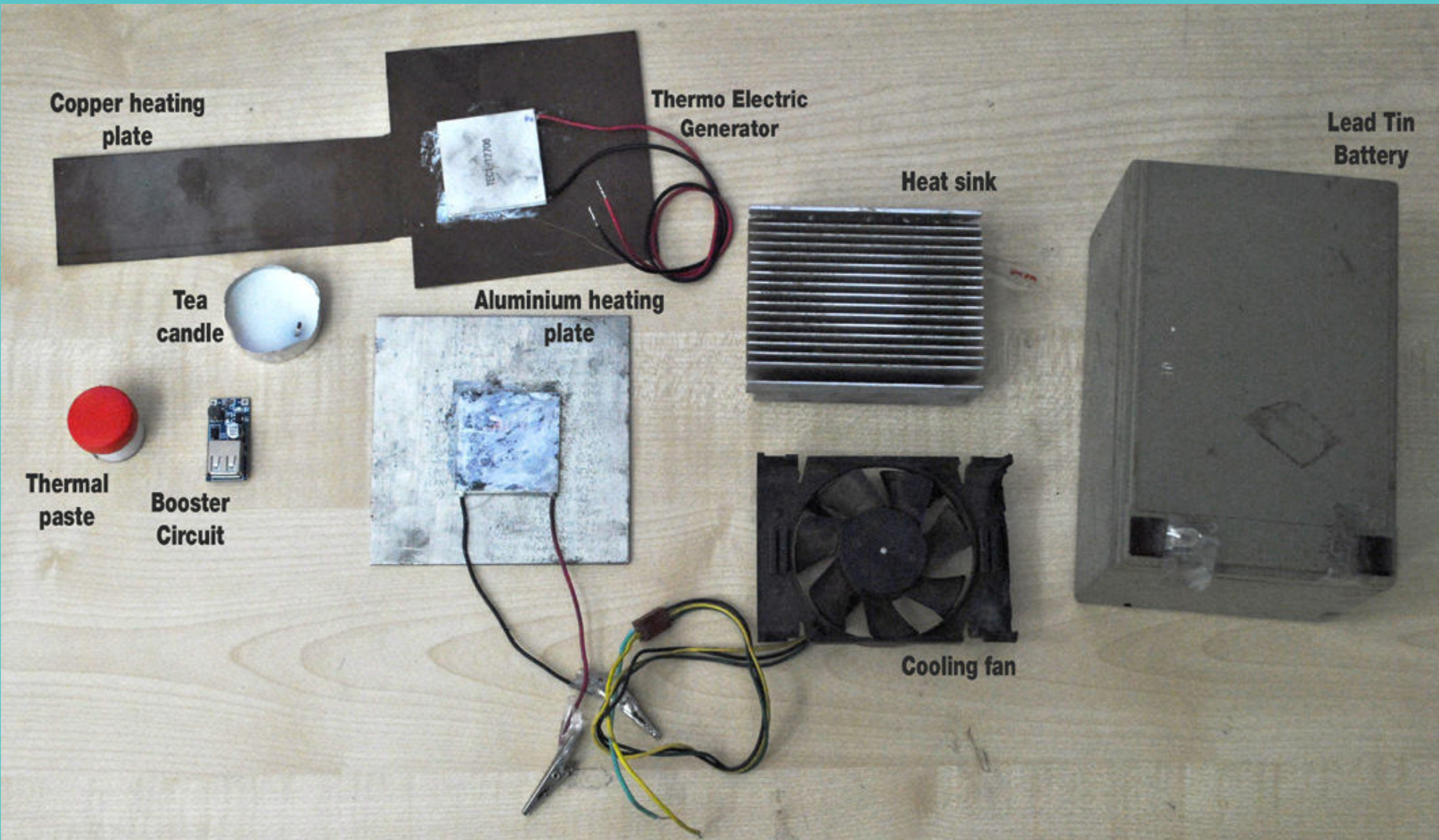

1. Thermo Electric Generator(TEG)

Temperature (degrees)	20	40	60	80	100
Open circuit voltage(V)	0.97	1.8	2.4	3.6	A
Current (MA)	225	368	469	558	669

2. Heat Sink

Old CPU Cooling Fan (12v) and Heat sink (aluminium)

3. Thermal Paste:

Heat sink compound paste.

4. Heat exchanger used:

Aluminium vessel and plate of 2 mm thickness. Copper plate of 1 mm thickness.

5. Light: LED

Colour: Blue

Operating Voltage: 2.6 - 2.8 V

Operating Temperature : -40~+85 °C

Power dissipation : 120 W

Lumen : 0.3 Lumen

6. Battery: Pure LED TIN Battery

Voltage: 12V

Capacity: 12Ah

7. Heat source

Tea candles and Gas stove

8. Booster circuit

5v booster board to regulate the output power.

Experiment

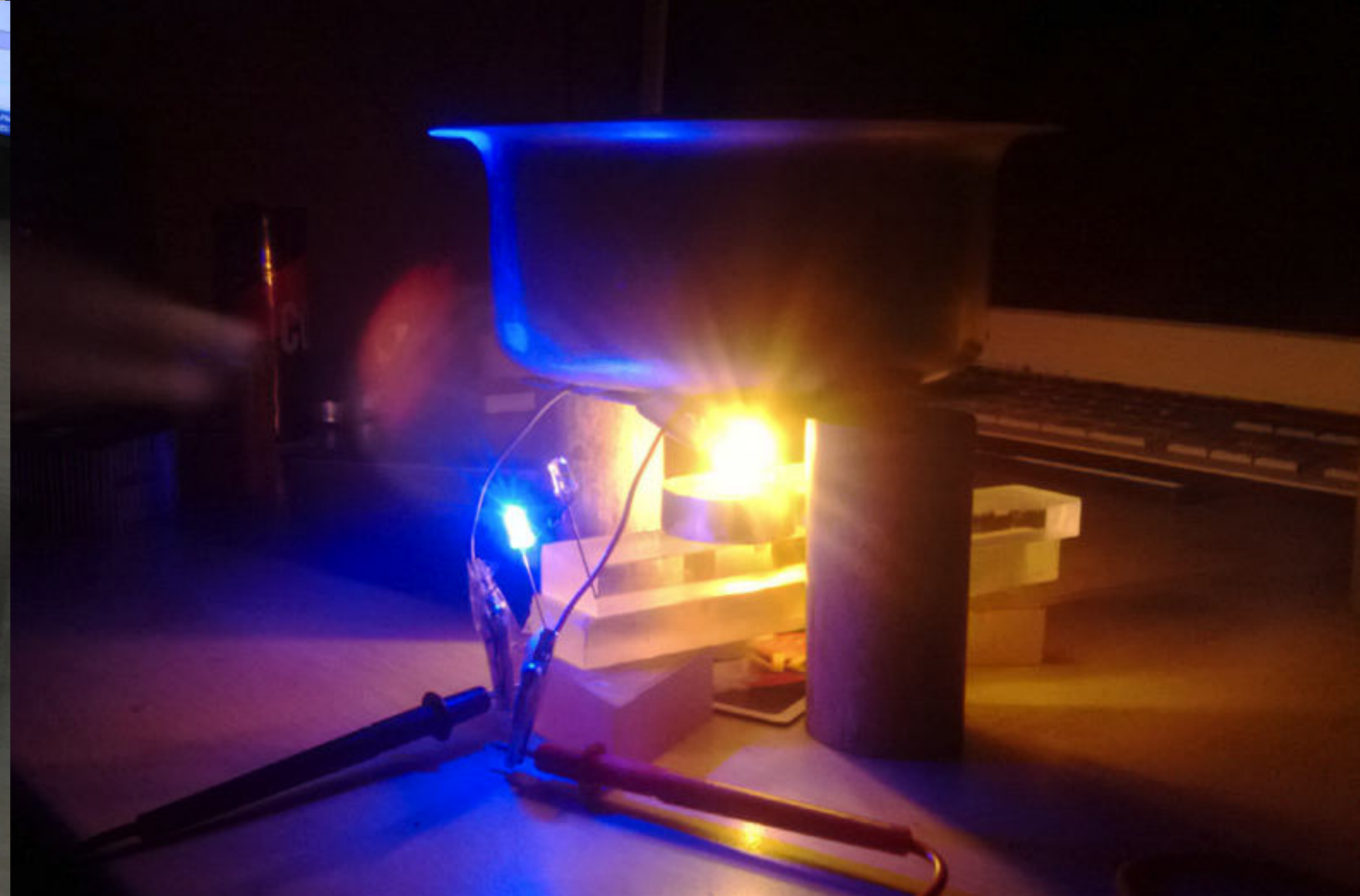

Experiment

	Exp 1	Exp 2	Exp 3	Exp 4	Exp 5	Exp 6	Exp 7	Exp 8	Exp 9	Exp 10	Exp 11
Heat source:	3 Tea Candles	3 Tea Candles	3 Tea Candles	3 Tea Candles	3 Tea Candles	2 Tea Candles	3 Tea Candles	3 Tea Candles	Commercial gas stove	3 Tea candles	4 Tea candles
Heat side sink:	Rectangular aluminium plate of 2mm thickness	Rectangular aluminium plate of 2mm thickness	Rectangular aluminium plate of 2mm thickness	Rectangular aluminium plate of 2mm thickness	Rectangular aluminium plate of 2mm thickness	Rectangular aluminium plate of 2mm thickness	Rectangular aluminium plate of 2mm thickness	Rectangular aluminium plate of 2mm thickness	Rectangular aluminium plate of 2mm thickness(24x5)	Rectangular Copper plate of 2mm thickness(24x5)	Rectangular copper plate of 2mm thickness(24x5)
Cool side sink:	Aluminium vessel with 1/2 litre water.	Aluminium vessel with 1/2 litre water.	Aluminium vessel with 1/2 litre water.	Aluminium vessel with 1/2 litre water.	Aluminium vessel with 1/2 litre water.	CPU cooling sink with fan	CPU cooling sink with fan	CPU cooling sink without fan	CPU cooling sink with/without fan	CPU cooling sink without fan	CPU cooling sink with/without fan
Distance from heat source to sensor:	Direct	15 cm	10 cm	8 cm	4 cm	Direct	Direct	Direct	15 cm	15 cm	4cm
Max voltage recorded:	4.2V	0.9V	1.2V	1.3V	1.5V	1.2V	2.8V	2.2V	2.1V	0.7v	2.9V
Light output:	good - Blue LED was ON	No output	No output	No output	No output	no output	light on	light off	No output	No output	yes
Time:	4 mins					5 mins	6 mins	3 mins	15 mins	10 mins	5 mins

Experimenting with long plate to understand effect of heat exchange

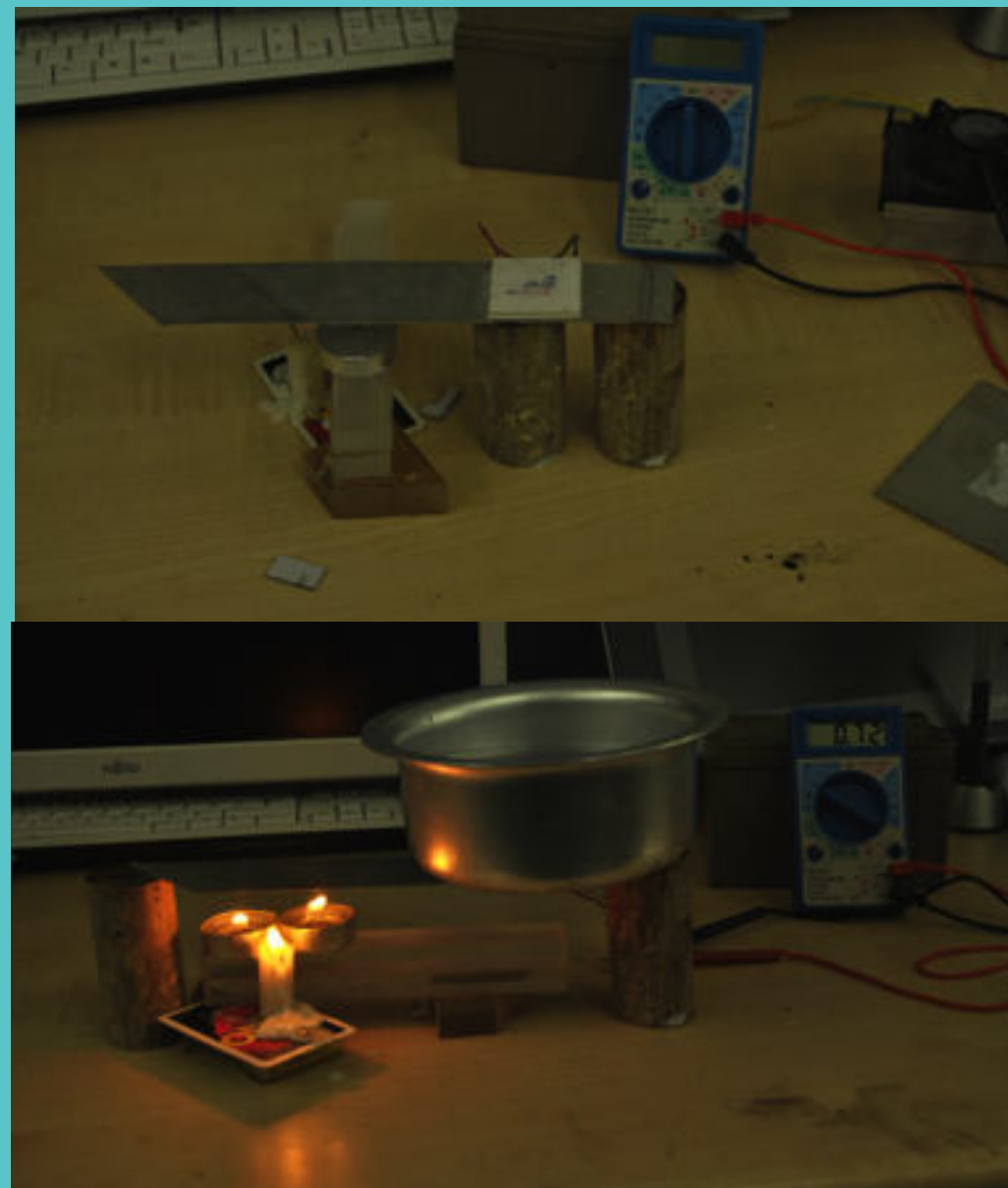

Experimenting with fan cooled sink and cooper heat sink.

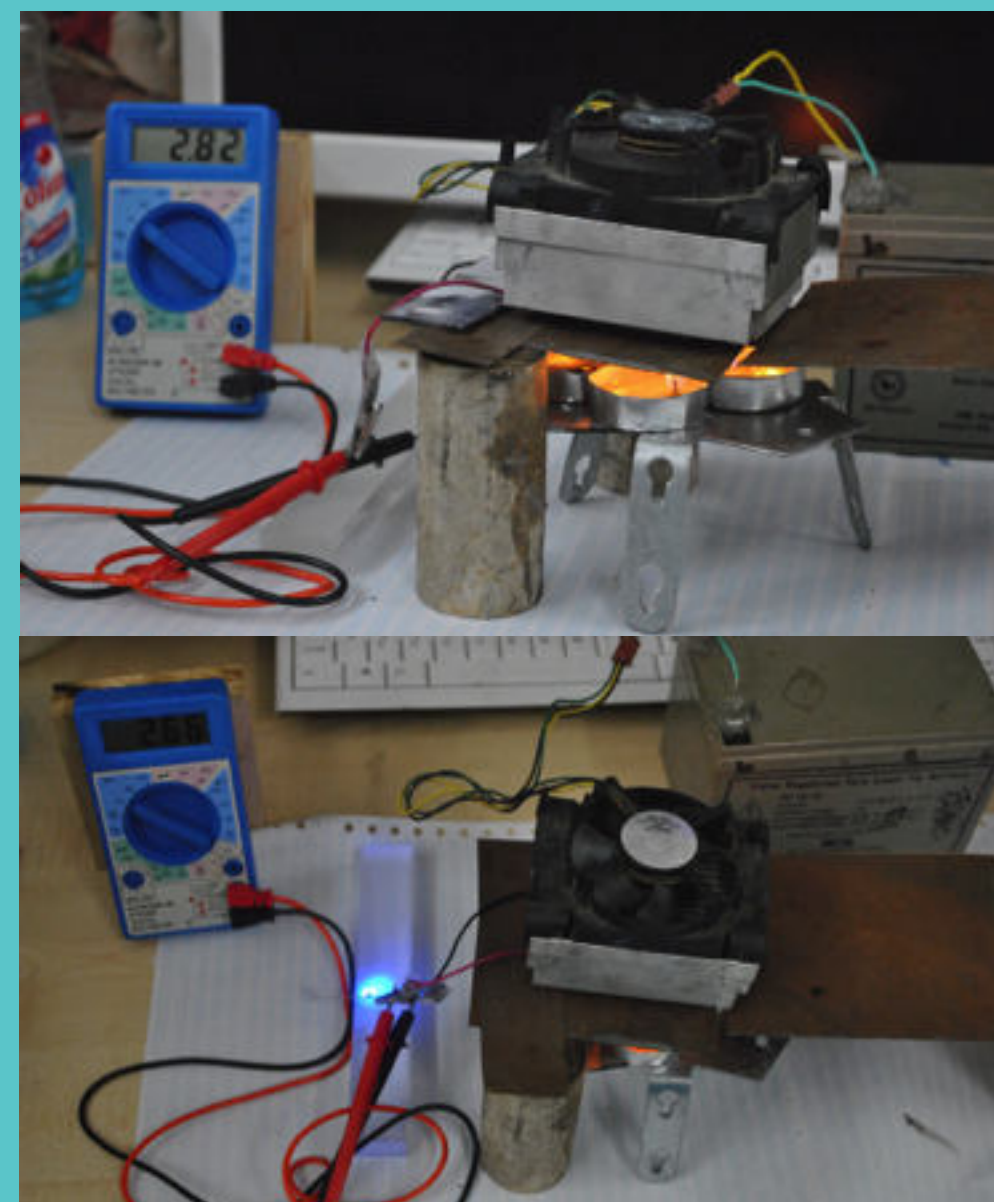

Experiment with commercial gas stove and fan cooled sink.



Insights from the experiment:

- Direct heating of the sensor with aluminium vessel filled with water produced the maximum voltage, which is by far the maximum difference of temperature.
But the consistency of voltage will be lost, when the temperature keeps rising.
- When the distance of heat source is extended from the sensor the transfer of heat is inefficient.
- But the water cooling is unmanageable in size, when compared to the fan cooled sink.
- The output voltage with fan cooled sink has produced a decent voltage for powering a light, but it needs additional power to run the fan. which is difficult to achieve with the available sensor.
- Aluminium plate can't stand the high temperature (660.32 °C), and the efficiency of heat transfer is low, compared to copper(1084.62 °C), hence copper which is a best available heat exchanger can replace aluminium.
- The distance between the heat source and the sensor has to be maintained as close as possible, for more efficient heat transfer.
- Initially it takes some time to generate the required power. Have to look for alternative to sort this.

Scenario study





Final Design Brief

Design a device to produce power, using Thermo electric generator and use it for the secondary lighting during power cuts and load shedding.

The device should function as a replacement for the torch lights and emergency lights in middle class houses of India which uses gas stoves. It should also have to work with the conventional grid power and should support charging of mobile phones and low power gadgets.

The main objective is to enhance the reliability and efficiency of lighting by saving cost and power.

The device should go with the other kitchen elements.

Mind Map:

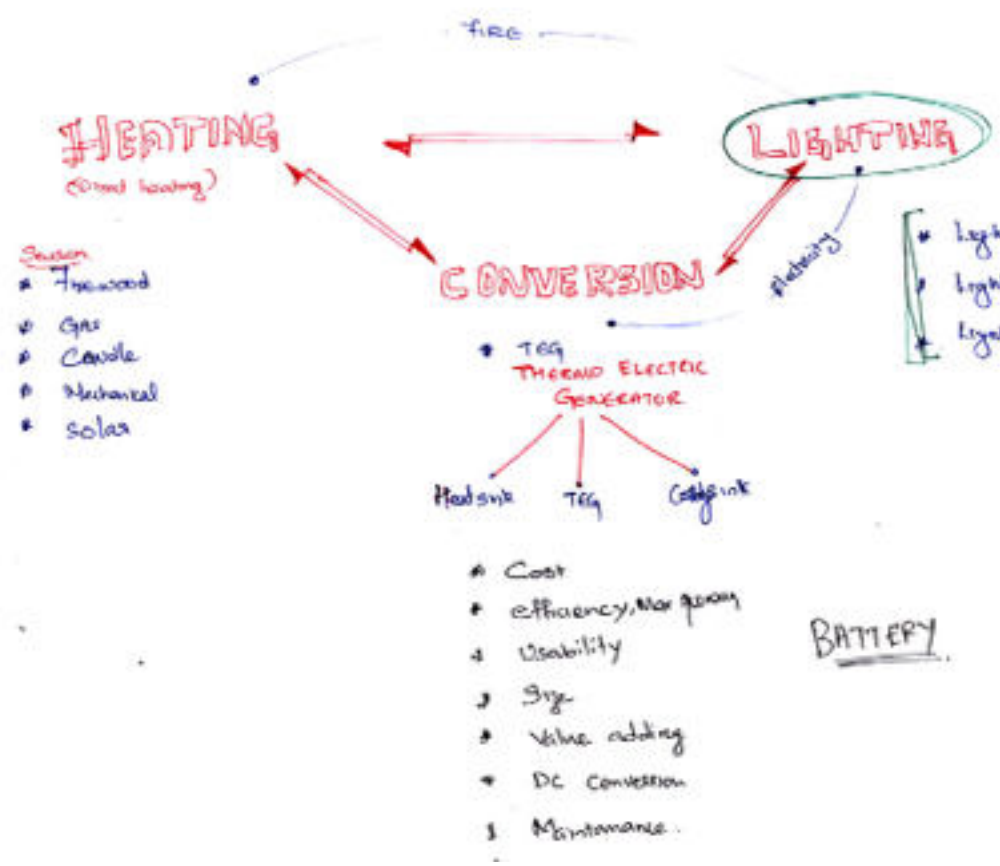

Can I make my kitchen self lit.
 Switch on the light/ gradually TEG will take over the LED lighting.

Same as Kitchen Middle class with grid power.

- Time delay of the light to reach full power
- Cooling
- Battery storage & backup
- cultural elements

BATTERY

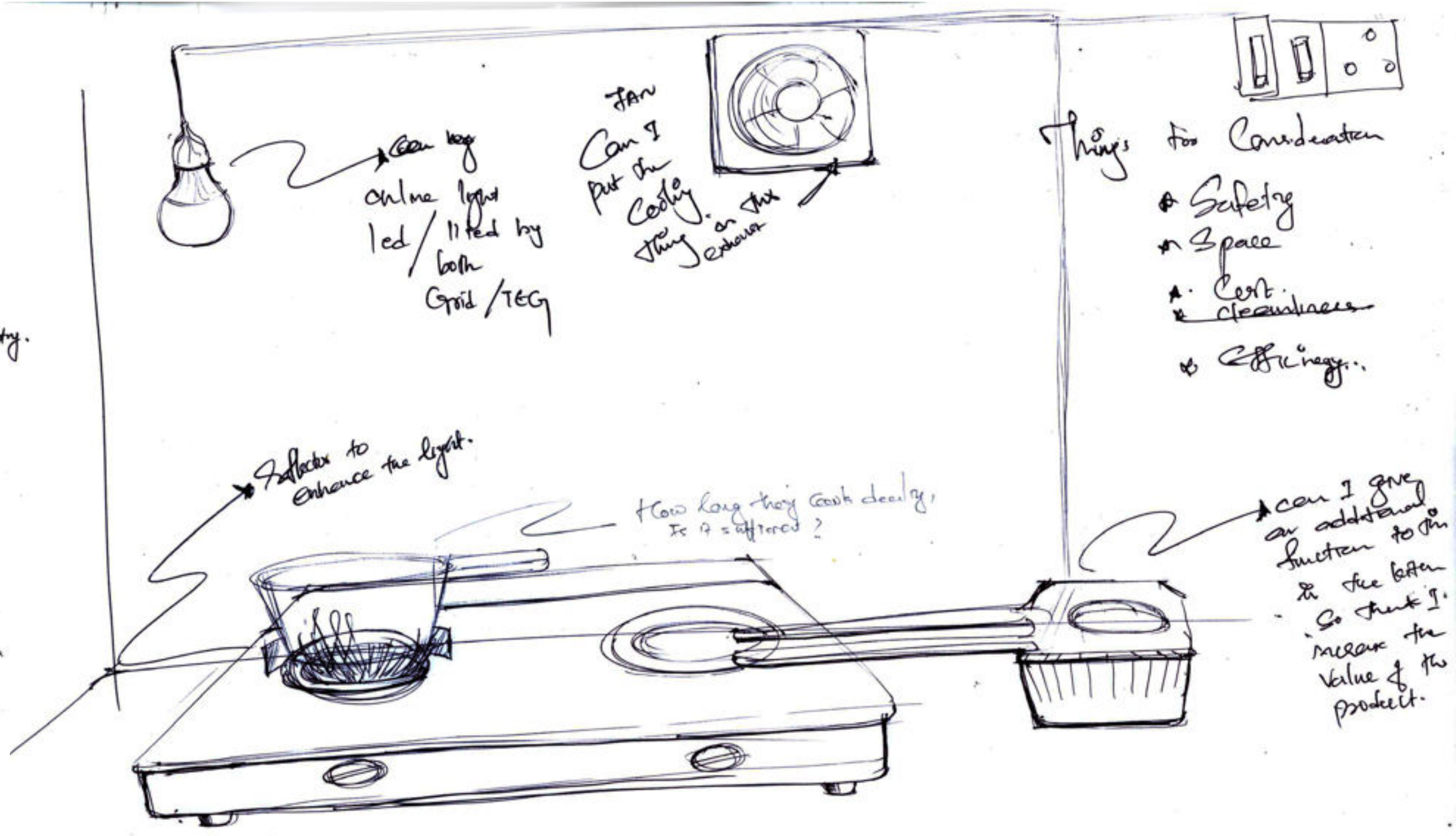

- Things for Consideration
- Safety
 - Space
 - Cost
 - cleanliness
 - Efficiency

Can I give an additional function to the battery & the better so that I measure the value of the product.

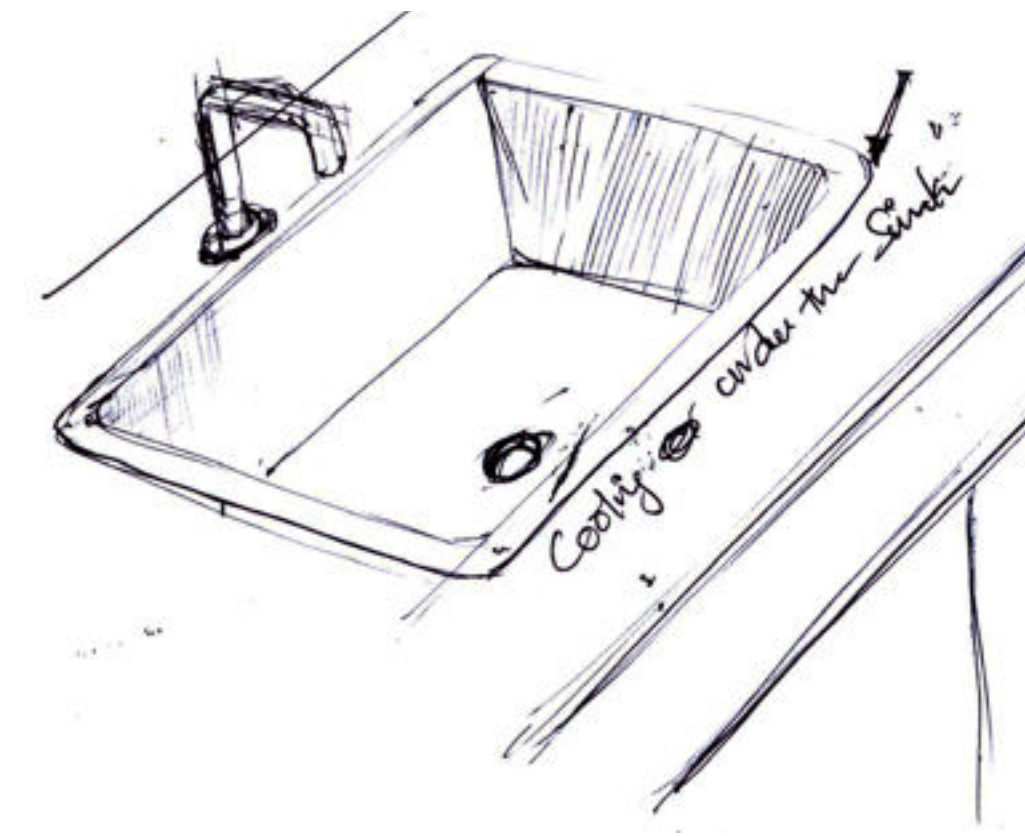

- Understanding TEG
- power (AC/DC)
 - storage (on time/battery)
 - Size, [efficiency]
 - Possible distance it could be taken

What about the people who use firewood stove?

Need another cheap & low capacity version.

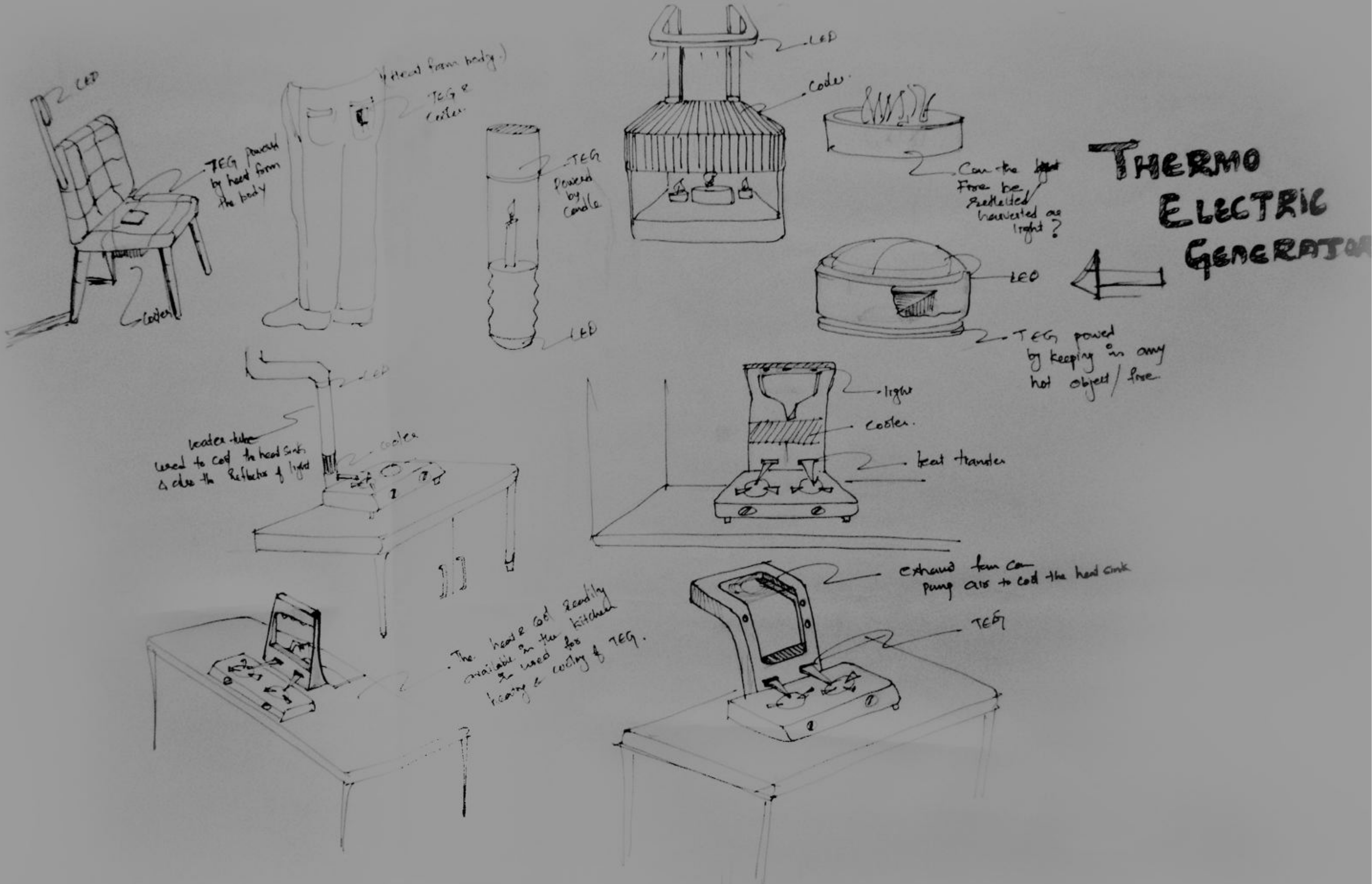

Idea 1: TEG Powered by existing sources and energy har-vesting method.



Can I activate the light from the fire & use it!

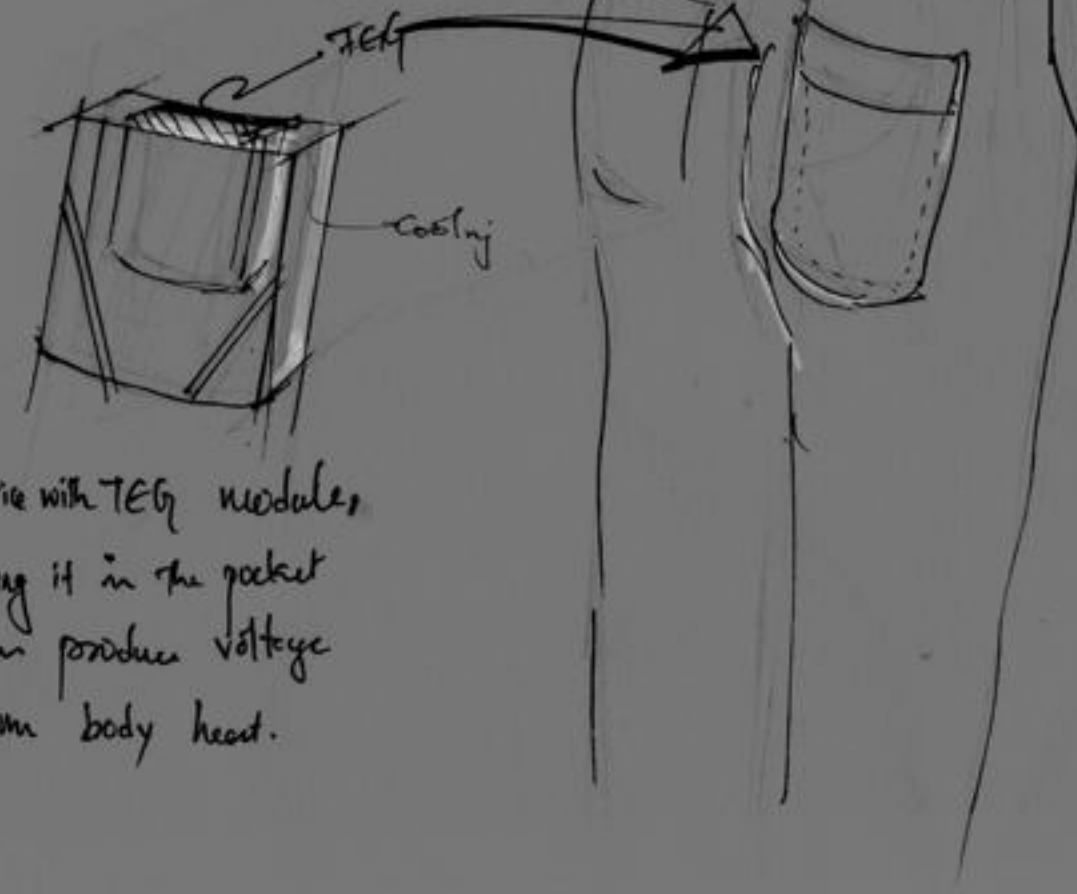

A device with TEG modules, keeping it in the pocket can produce voltage from body heat.

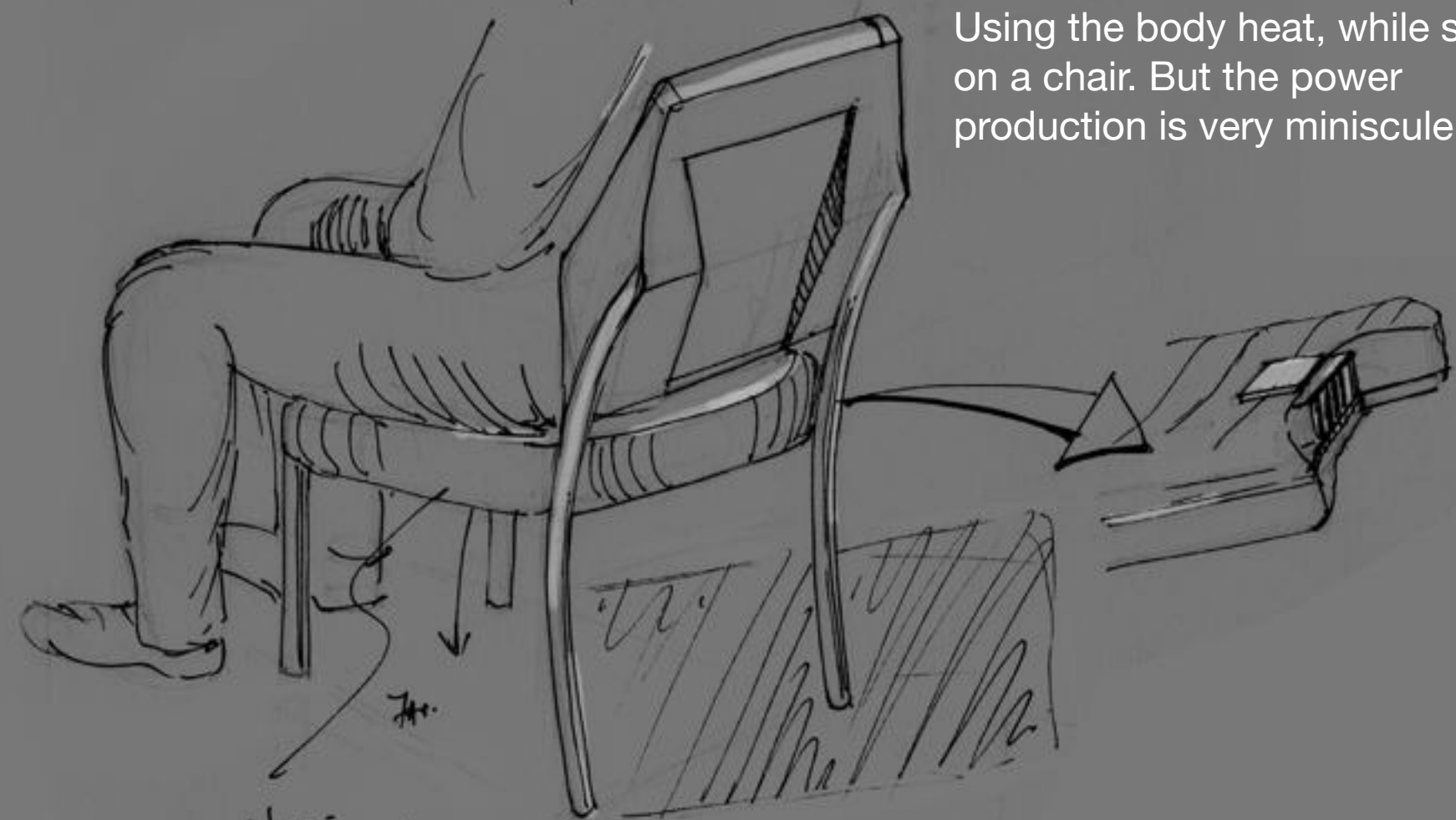

Using the body heat, while sitting on a chair. But the power production is very miniscule.

TEG Module... Under the seat which works with human body heat.



Device attached to the stove.

The idea is to produce light from the existing stove, But due to safety concern because of the excessive heat dissipated from the sink and the lack of air flow inside the stove, made it unproceedable.

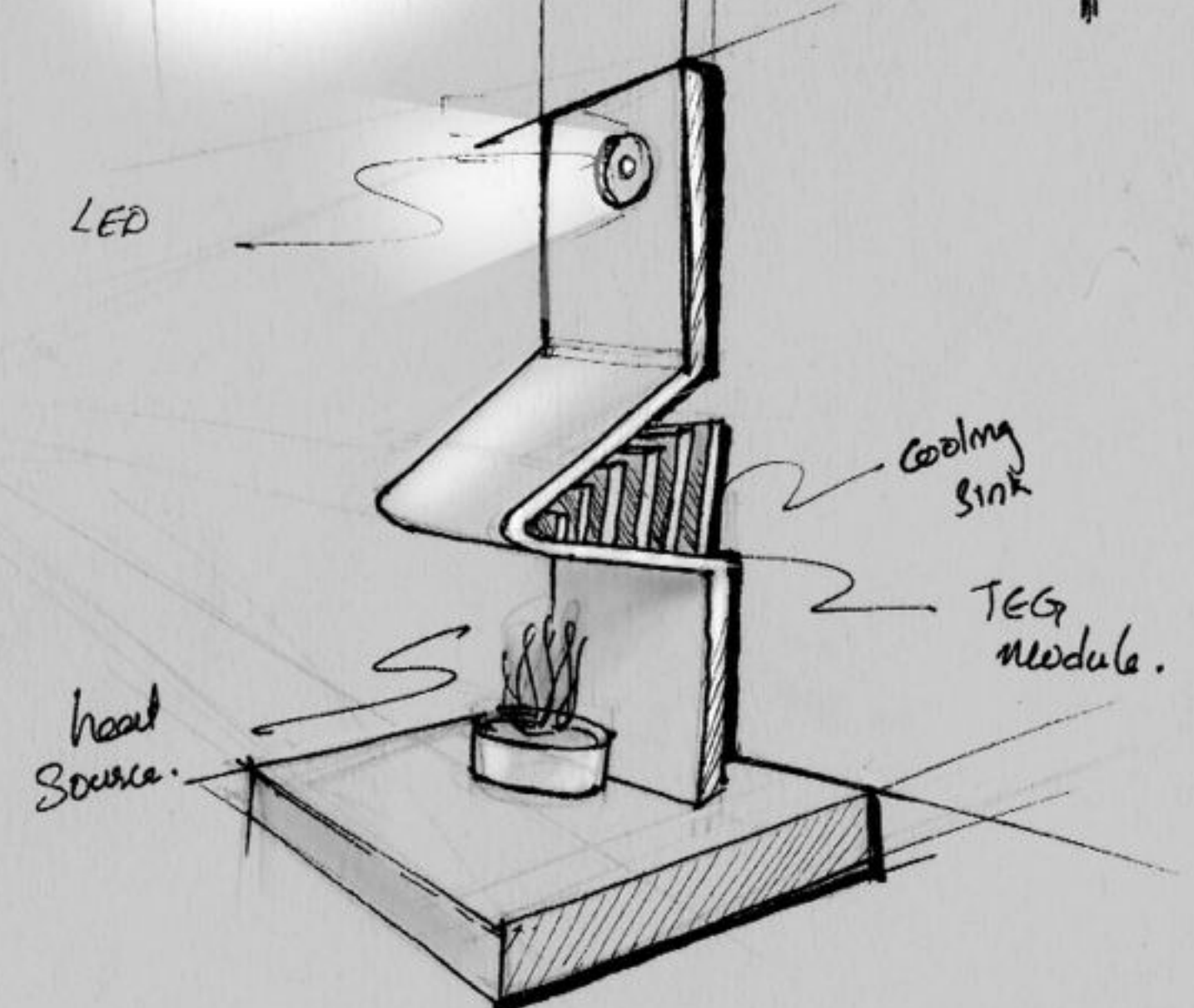
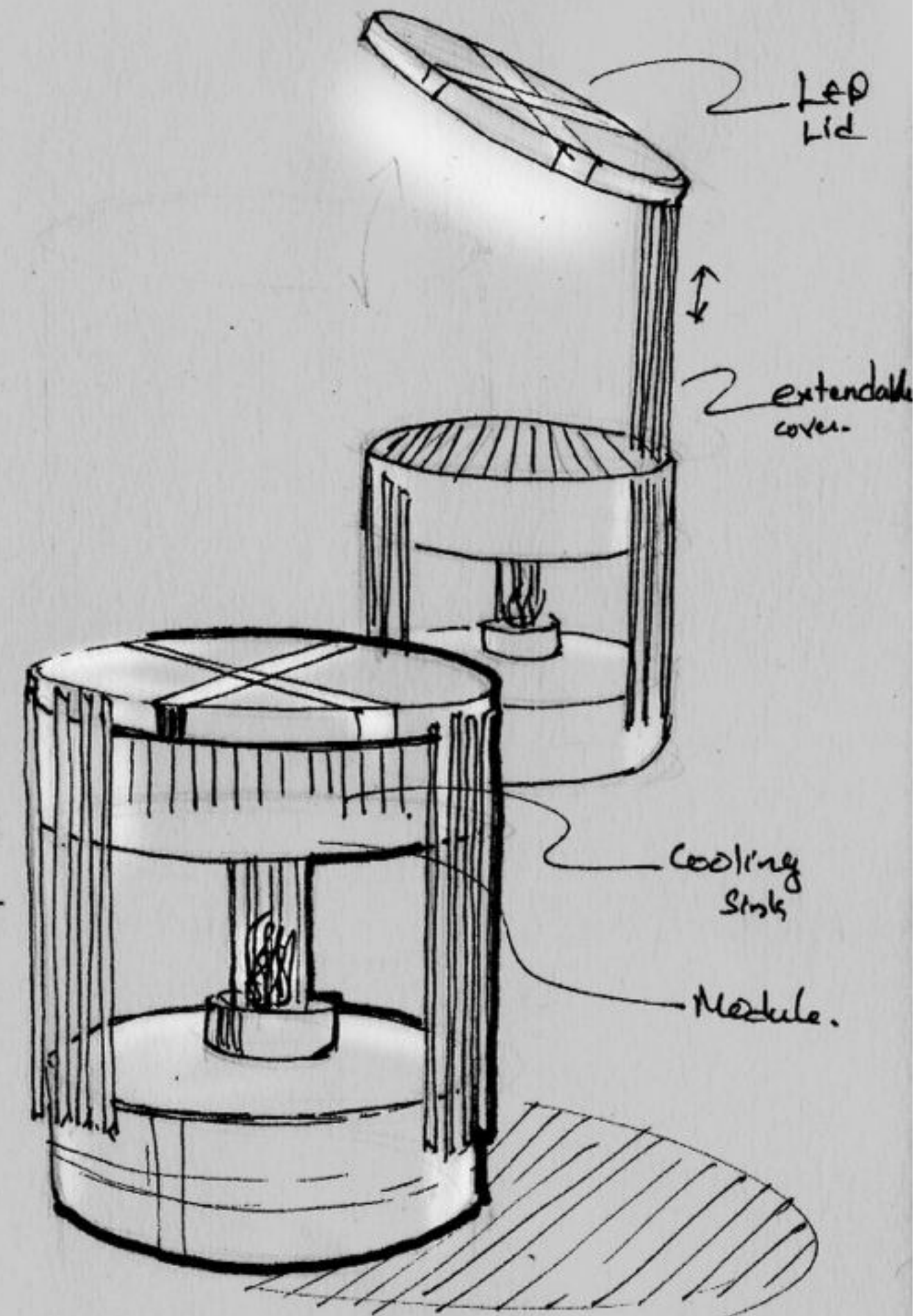
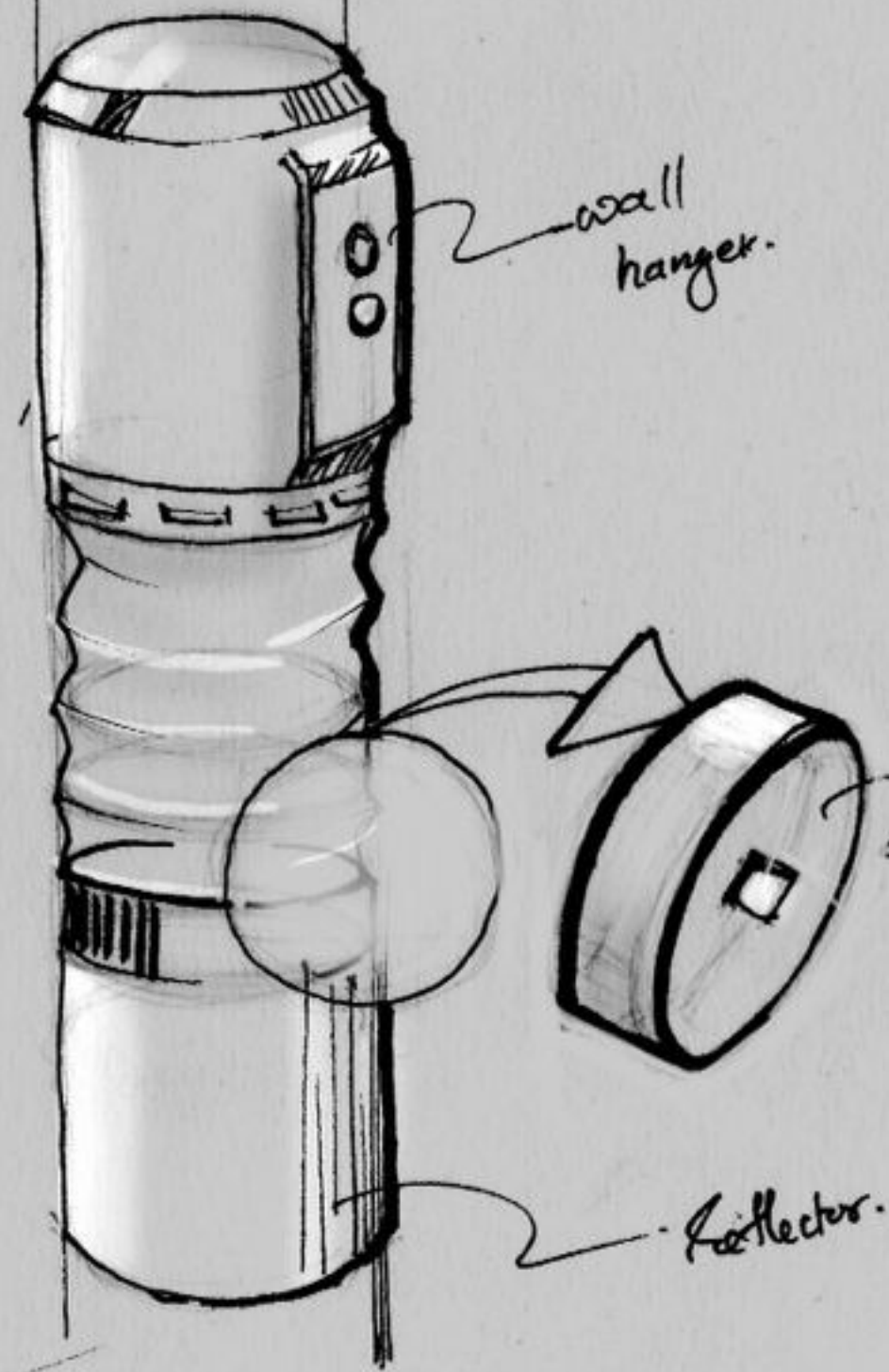
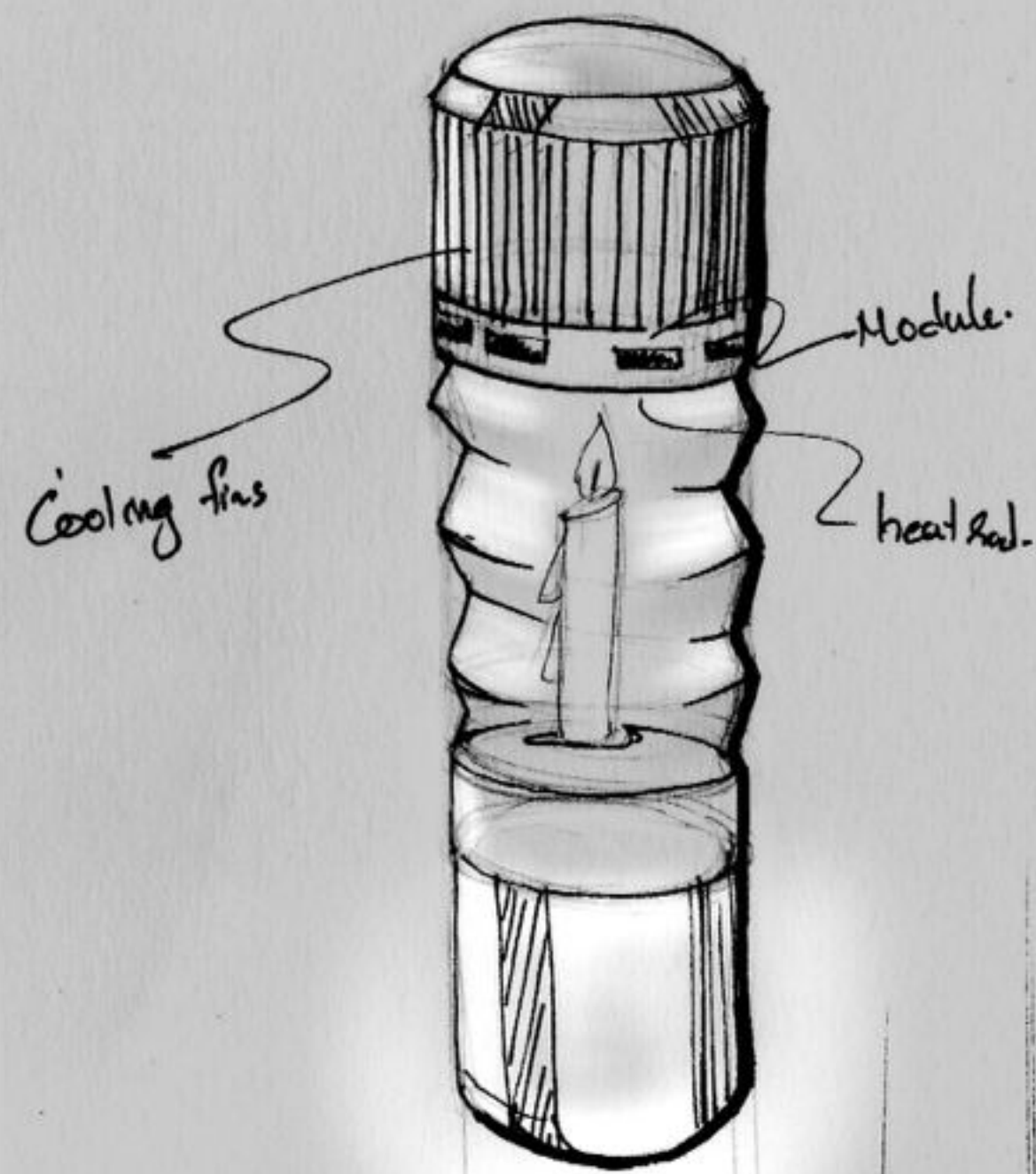

Idea 2: Direct Heating
 Simple and direct heating technique is applied to produce power and use it for lighting. This can be used outside the kitchen also. These ideas can just enhance the luminosity of light produced from a candle, with the help of LED's. The cooling fins and scalability of power production is not explored. This is not energy harvesting, It is dependent on candles and power storage option not recommended.

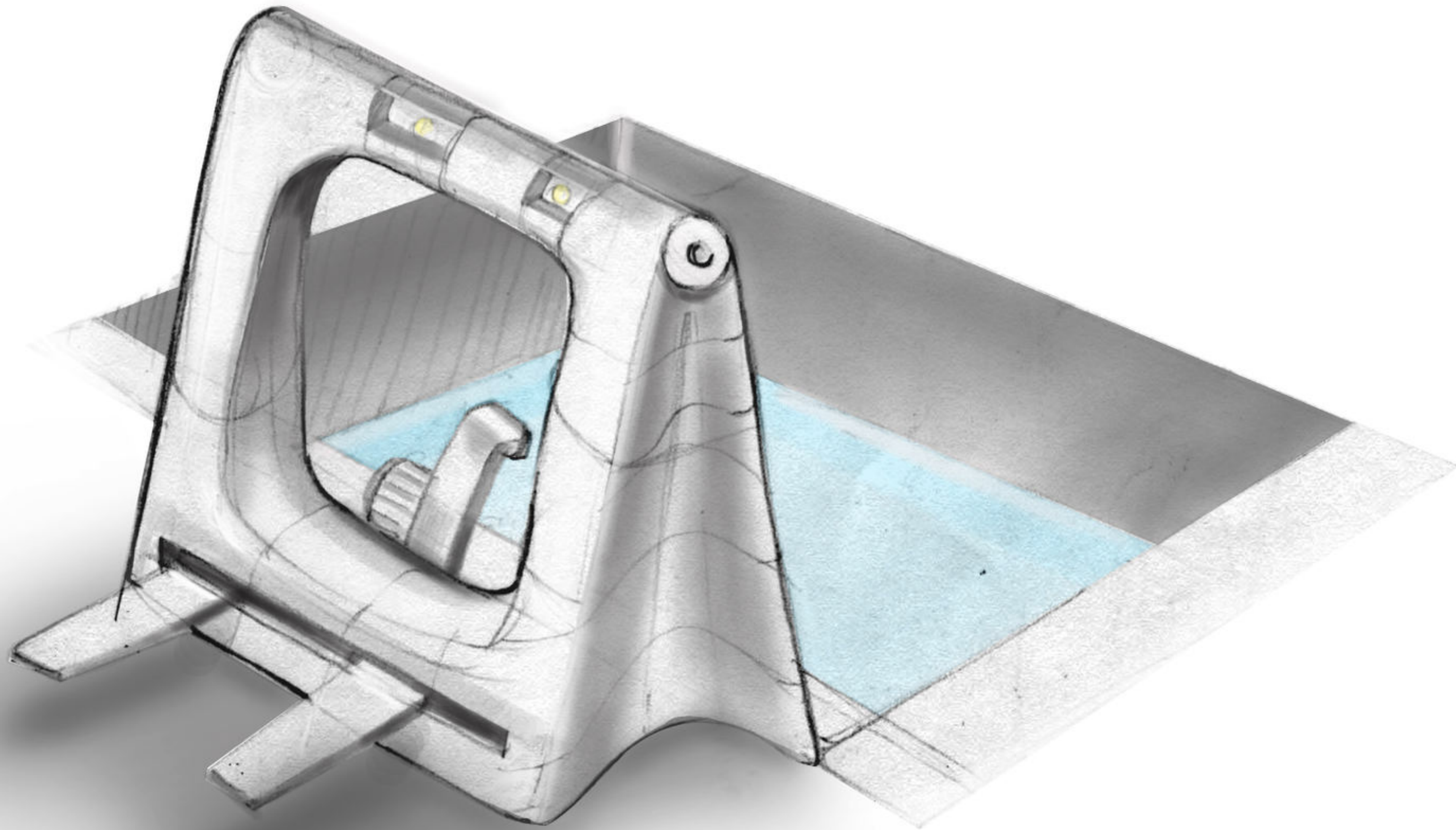

Idea 3: Water based cooling
TEG is powered by using the heat from kitchen stove and the cooling from the water sink. This idea gives the possibility of producing high temperature difference.
This could work only in island kitchen. hence it cant be applied to the existing stoves

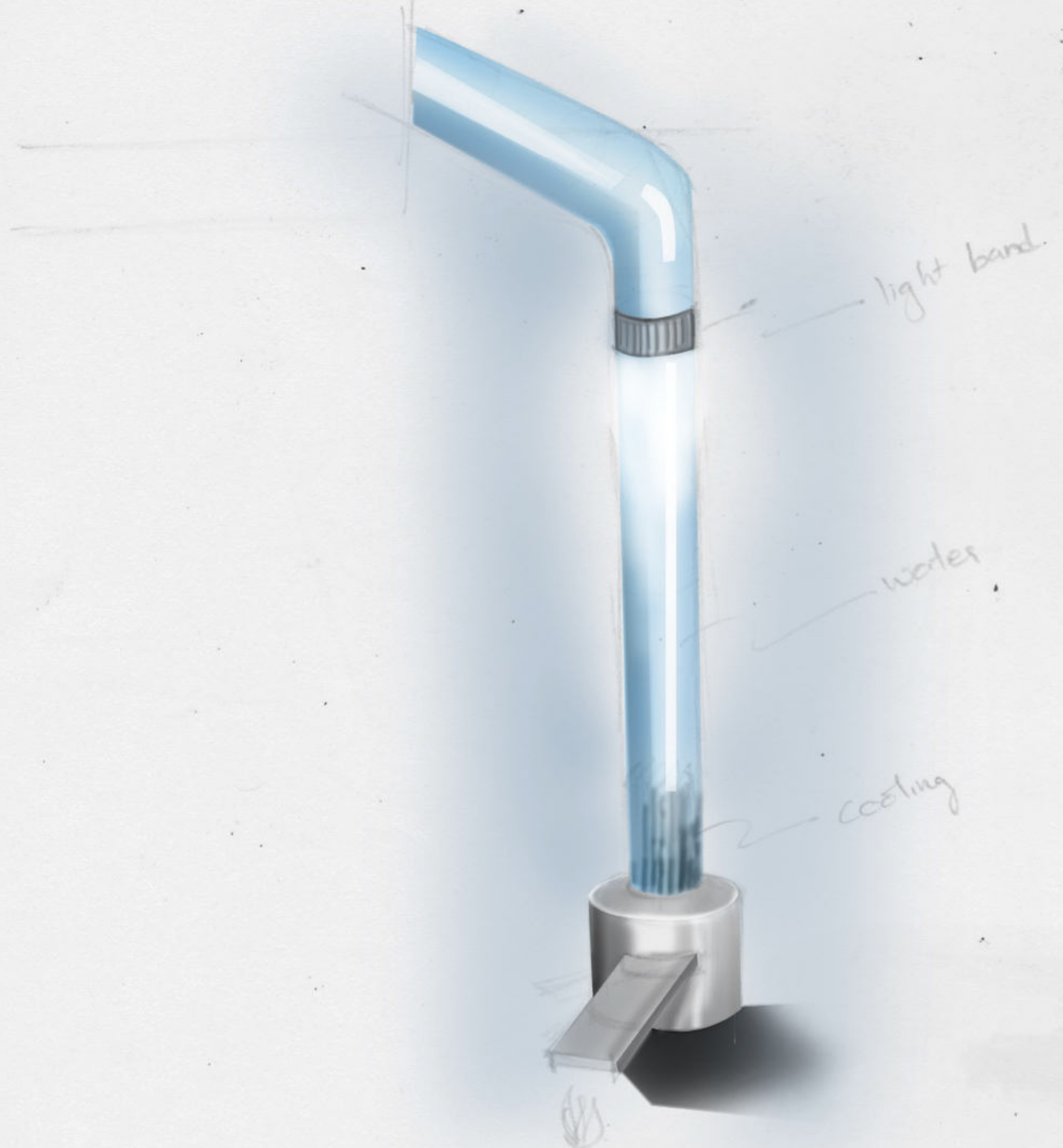

Idea 3: Water based cooling
TEG is powered by using the heat from kitchen stove and the cooling from the water tubes, which are solar tubes. This idea gives the possibility of producing high temperature difference. This actually is a hybrid lighting, but water which is stationary inside the tube tend to get heated very fast because of the cooling fins.

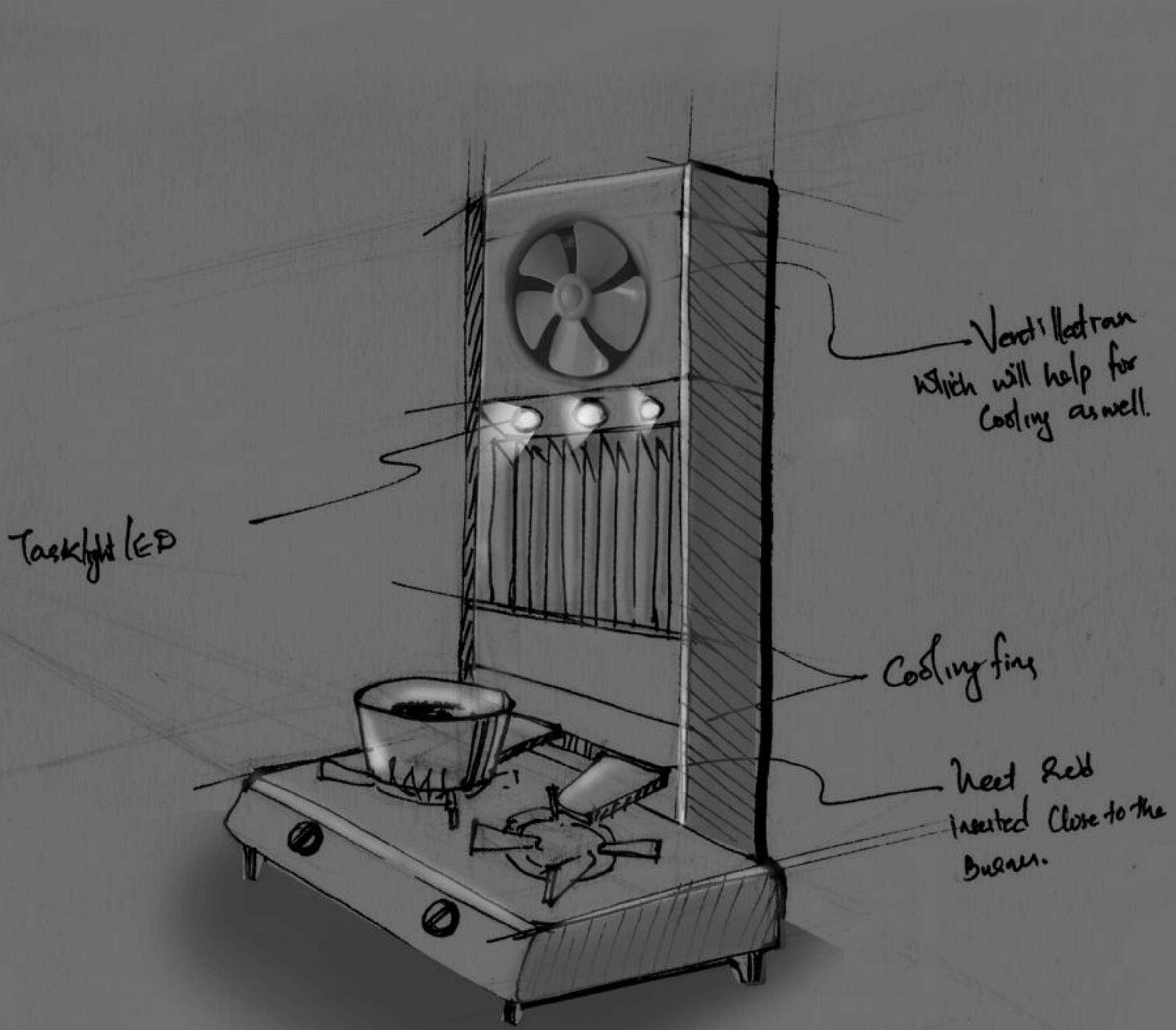

Idea 4: Cooling using ventilation in the kitchen
This uses the heat from kitchen stove and the cooling is done by the ventilation of the kitchen, which is powered by either grid power or power from TEG .
Ventilation is not very common in many of the houses in India, and running the fan in itself very power demanding

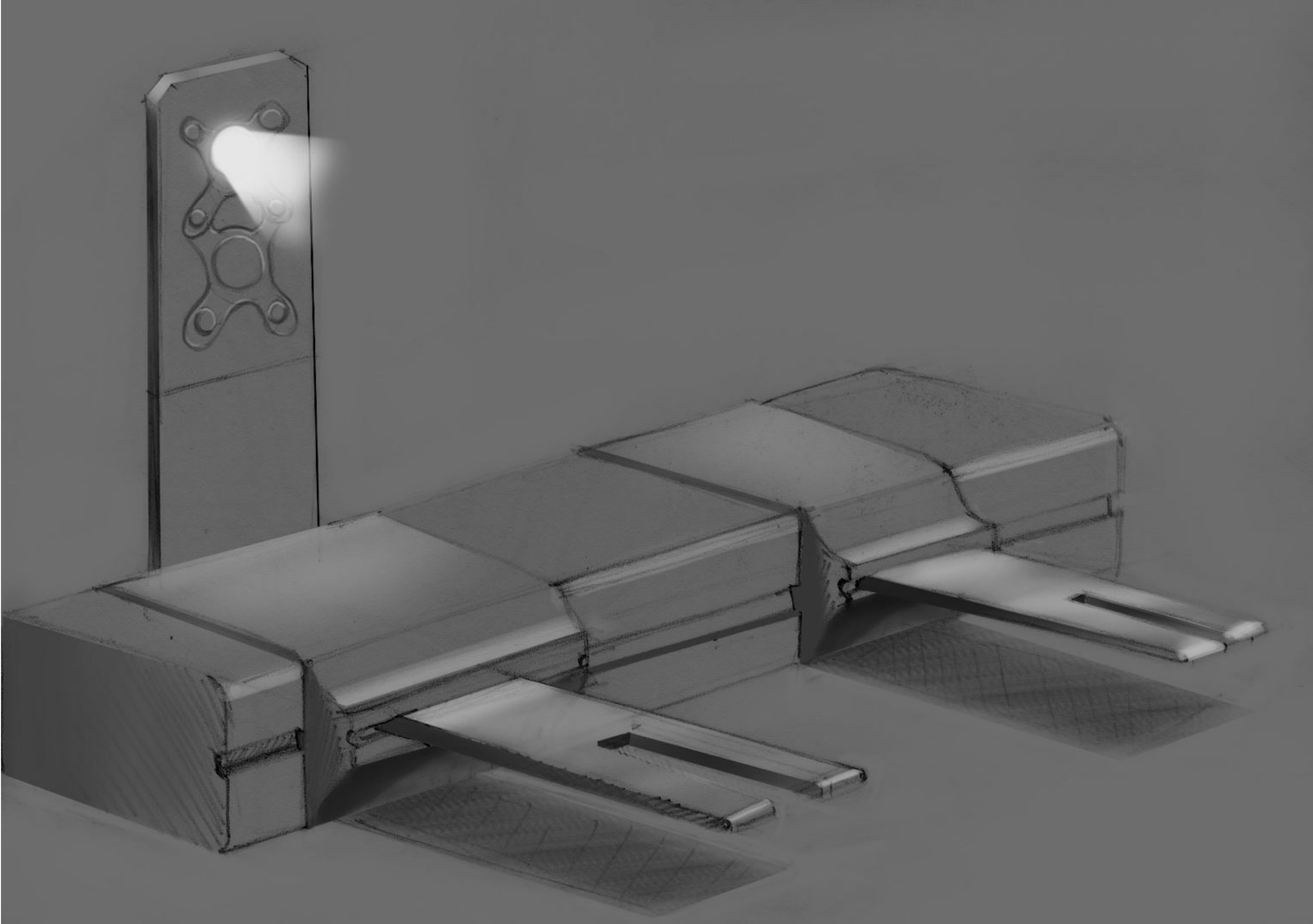

Idea 5: wall mounted TE generator:
The device is fixed to the wall, so that the space constrain between the stove and the wall could be sorted, considering the fact that the stove is not moved very often.
The lighting is adjustable and portable, but the device is fixed which is difficult for maintenance.
The device doesn't support cooling part of TEG

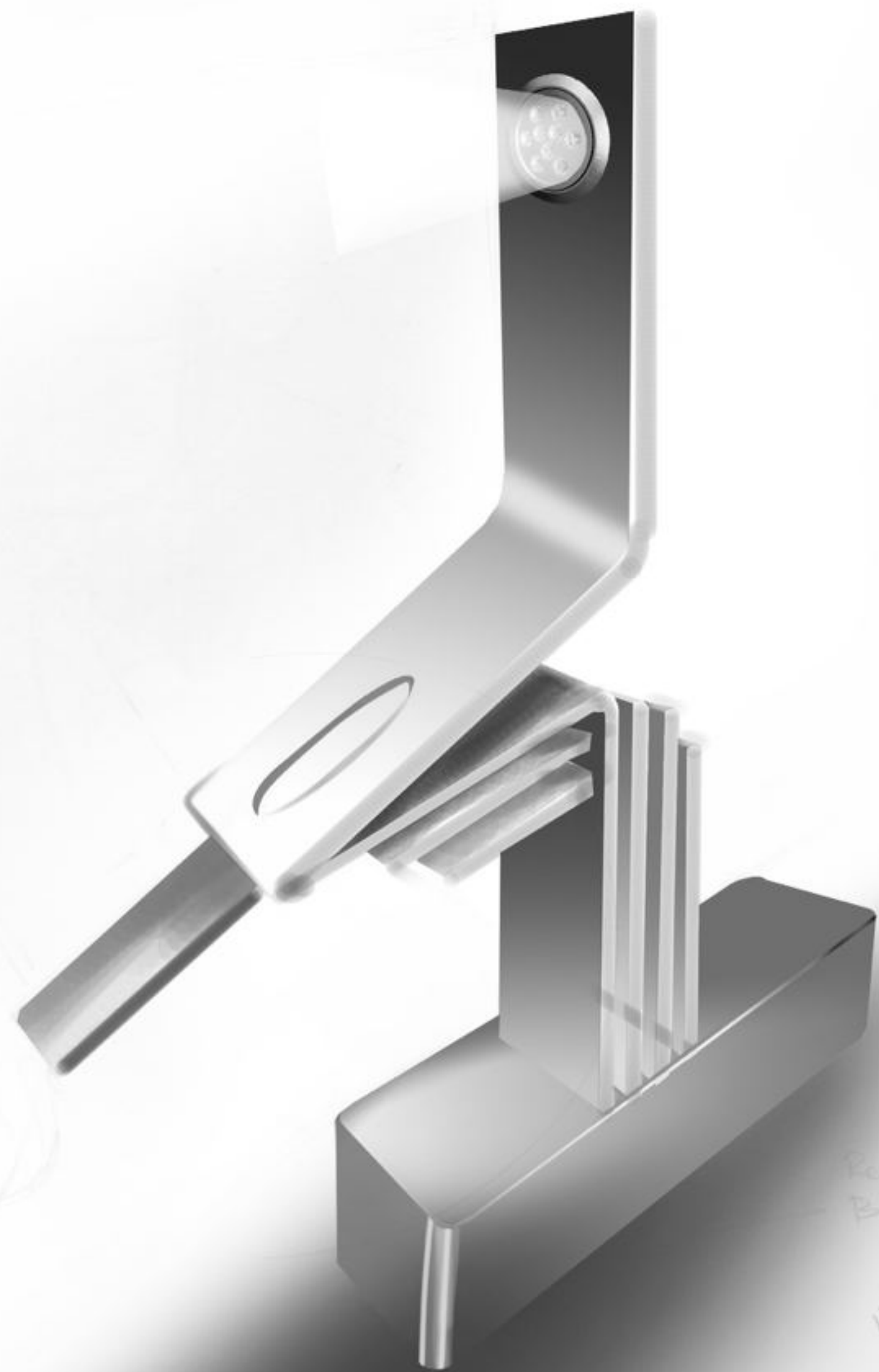

Rechargeable
Battery pack
[power pack]
issue! Battery Overcharging

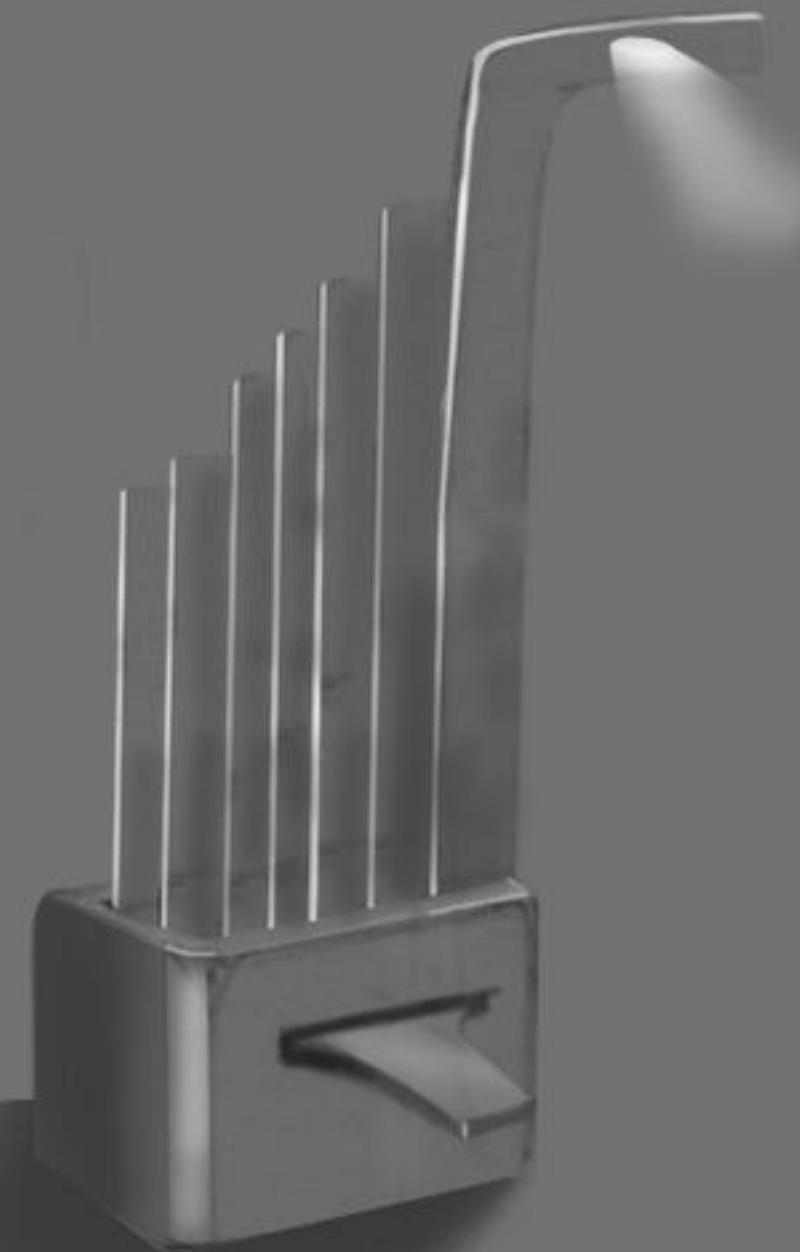

Idea 6: Cool cool fins
The device supports the cooling end. It will increase the efficiency of power production, but the base of the form is not compatible with the less and cramped kitchen space around the stove.
The form in itself will help in cooling the TEG.

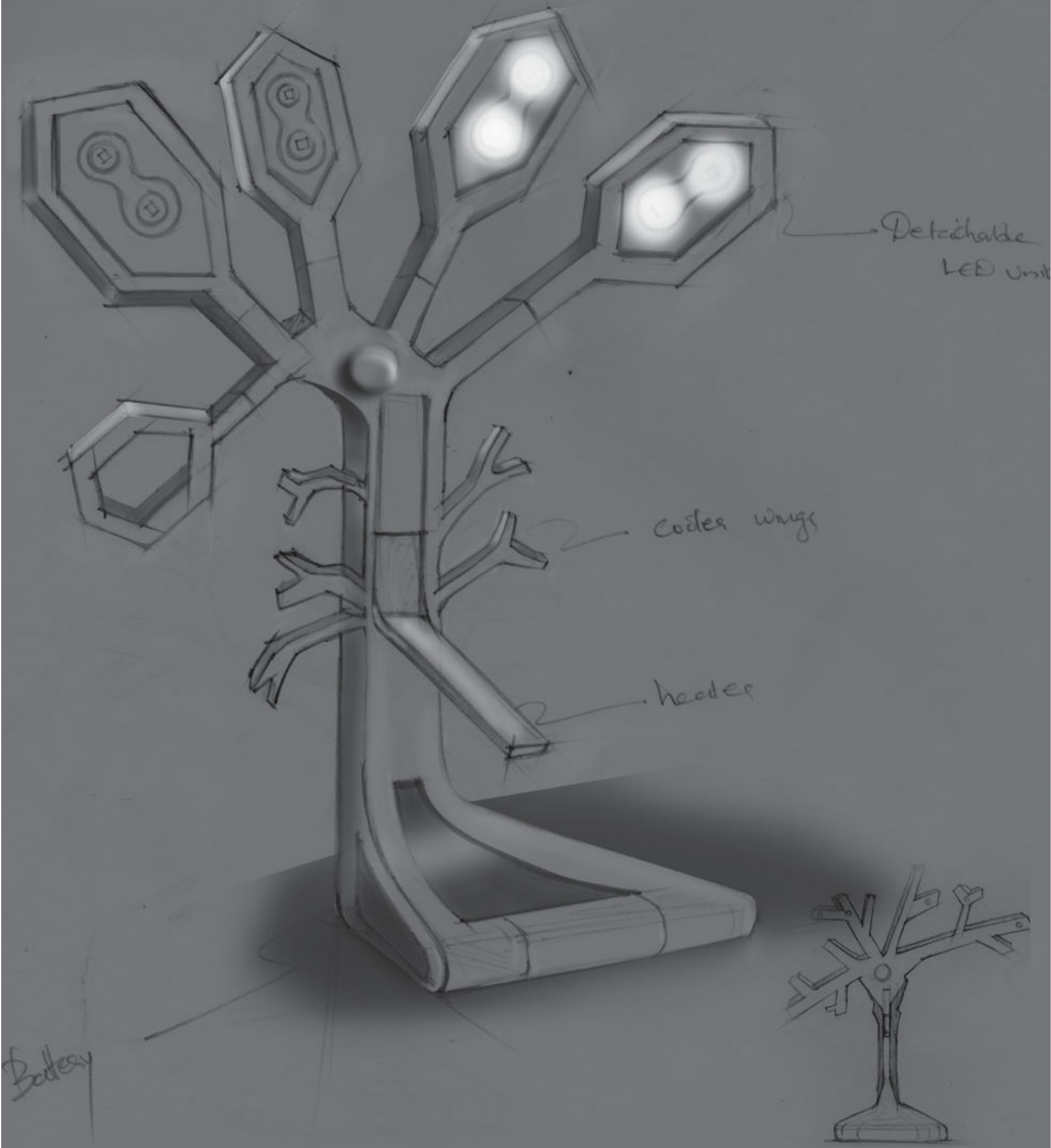

Idea 7: Power Tree

The device has the modular lighting ends, which will help in the portability of light as separate elements.

And the whole tree can act as the heat dissipating unit.

The device won't occupy much space behind the kitchen. Like tree the elements keep on increasing.

The problem is dissipation of the heat is not standardised. And it may affect the components.

Difficulty in maintaining the device from the spillages around the stove.

Evaluation

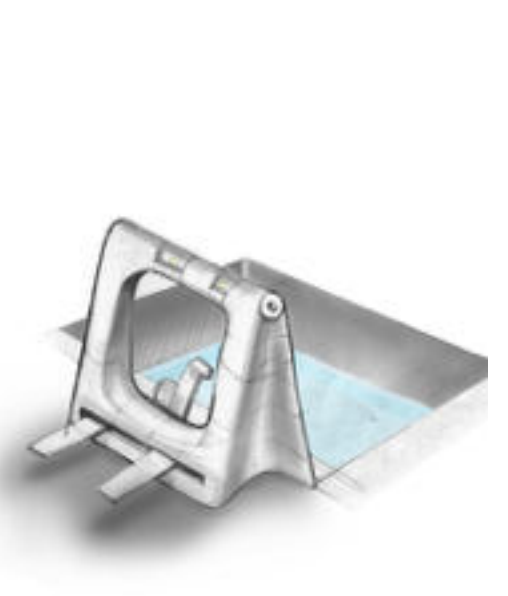
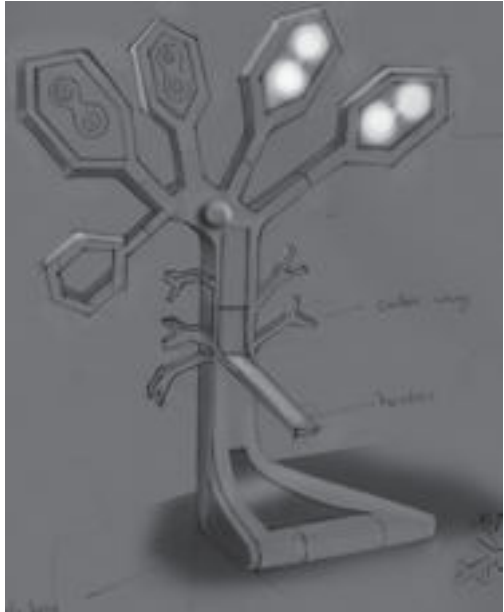
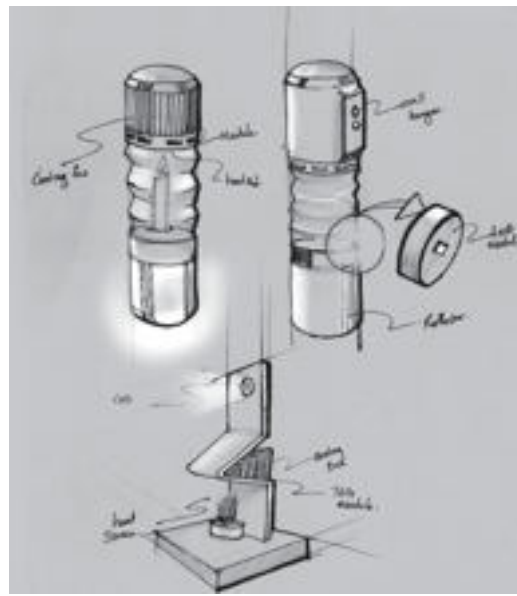

	Idea 1 (Direct Heating)	Idea 2 (Forced air-fan ventilation)	Idea 3 (Wall mounted)	Idea 4 (power tree)	Idea 5 (Cool cool sink)	Idea 6 (water cool)
Efficiency of Heating	4	3	2	3	3	3
Efficiency of Cooling	3	4	1	3	4	4
Portability and adjustability	4	2	1	4	4	2
Modularity of light	3	3	2	4	2	2
Multi functionality	2	4	2	4	2	4
Maintanance	4	3	4	3	4	2
Manufacturability	3	3	3	3	3	3
Total	23	22	15	24	22	20
Quanlitative:						
Battery capacity	no	yes	no	yes	no	yes
Additional support for power generation	yes	no	no	no	no	yes
Charging option	no	yes	yes	yes	no	yes
Grid connected	no	yes	no	yes	no	yes/ no

Exploration

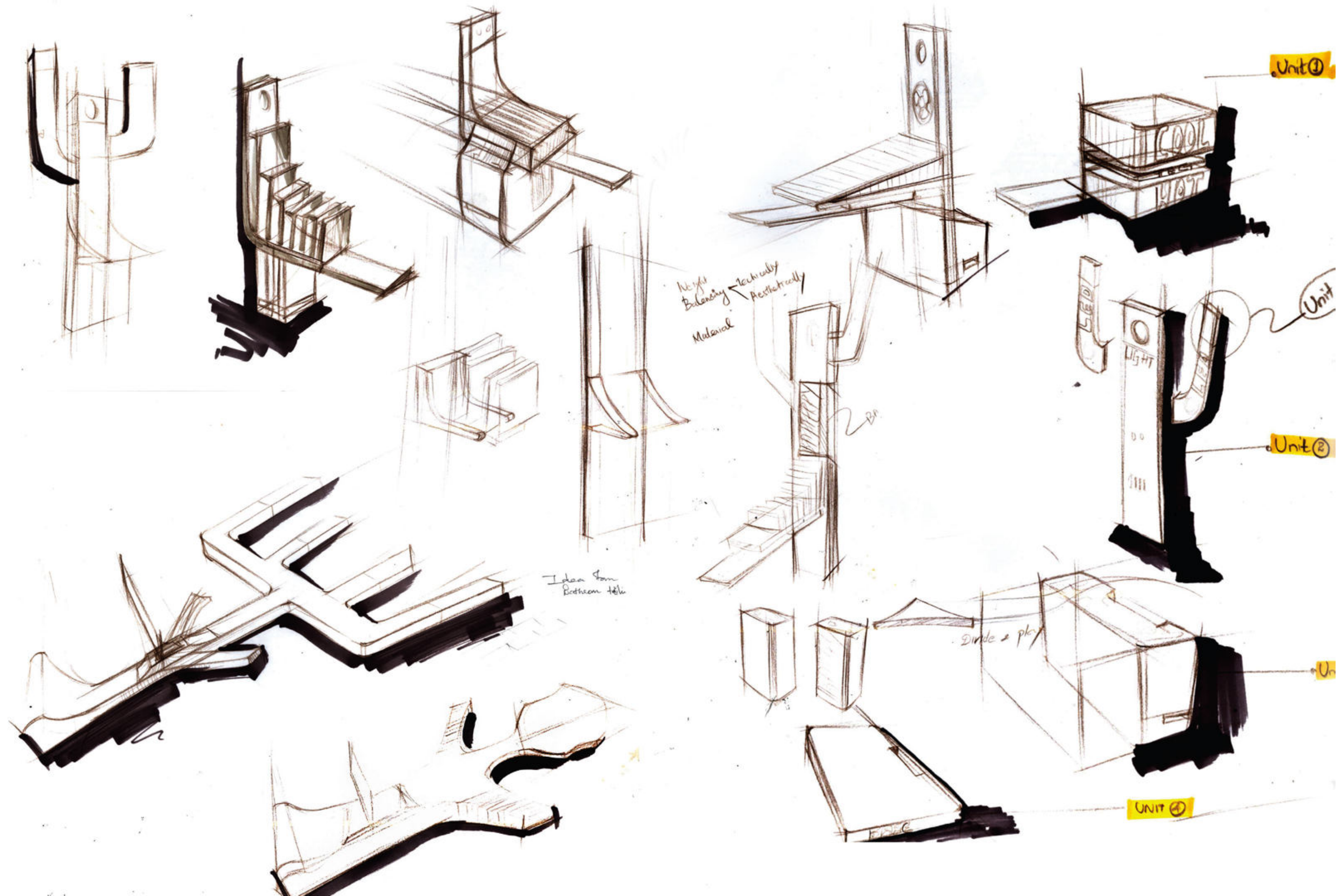

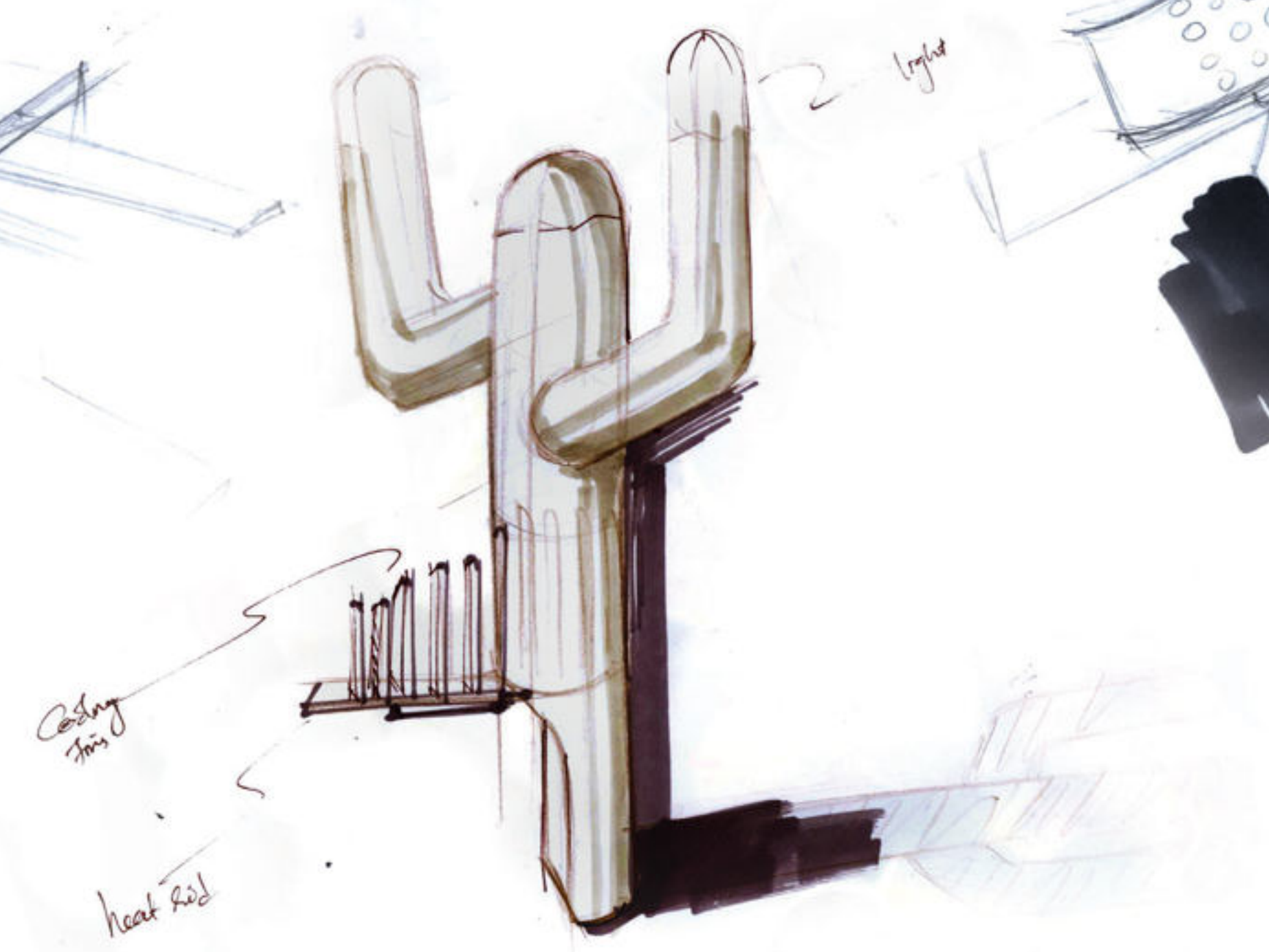
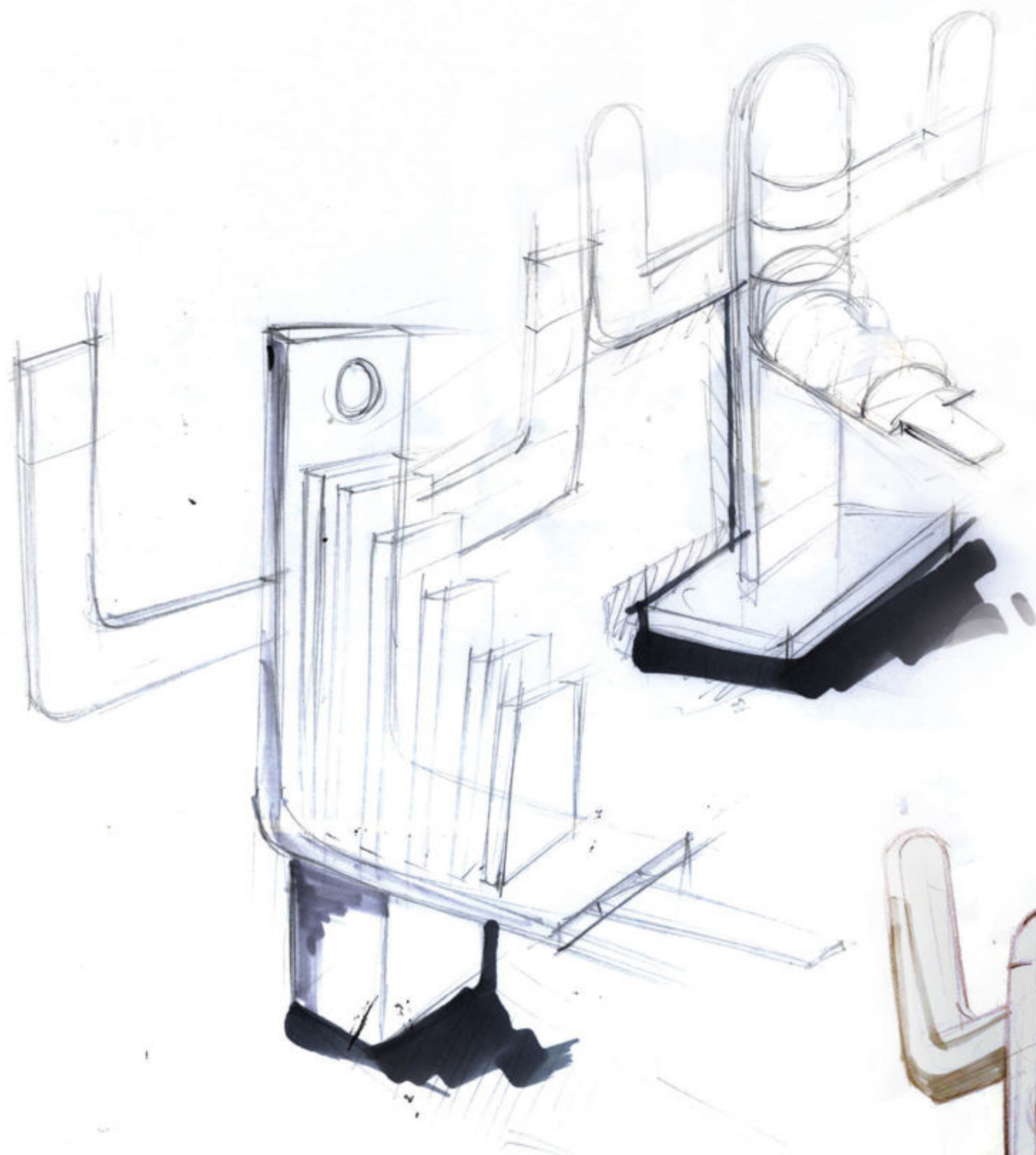

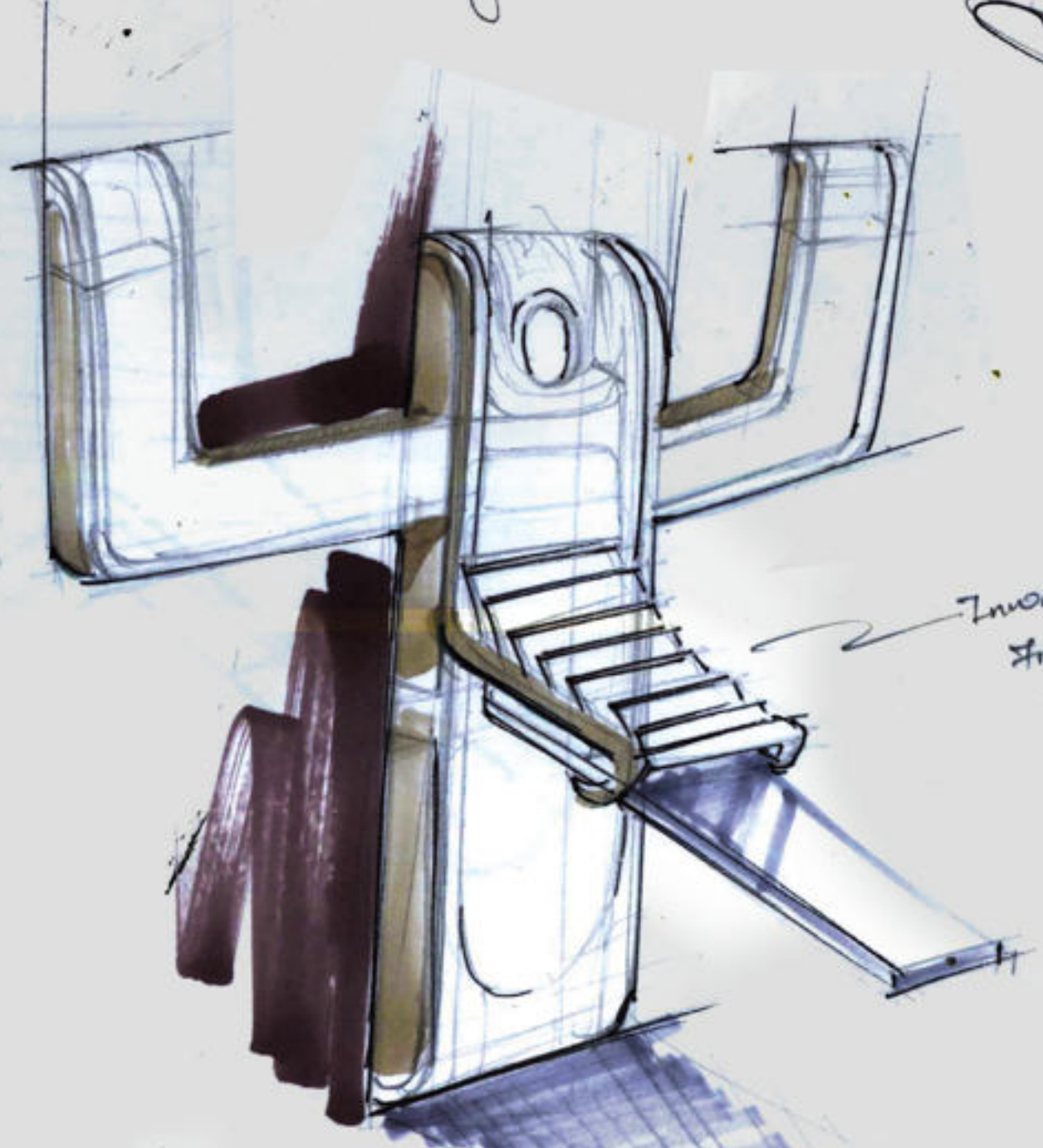
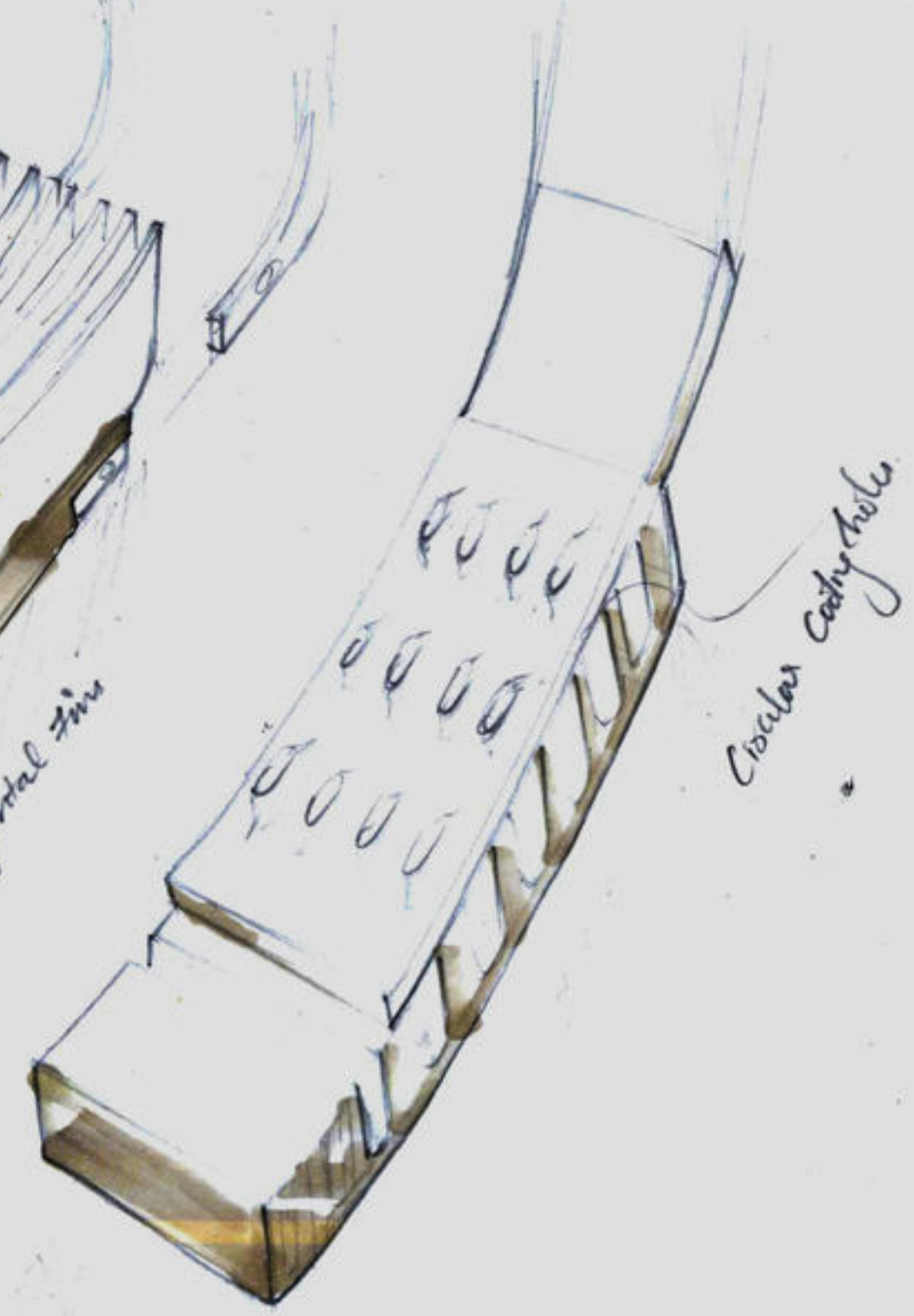
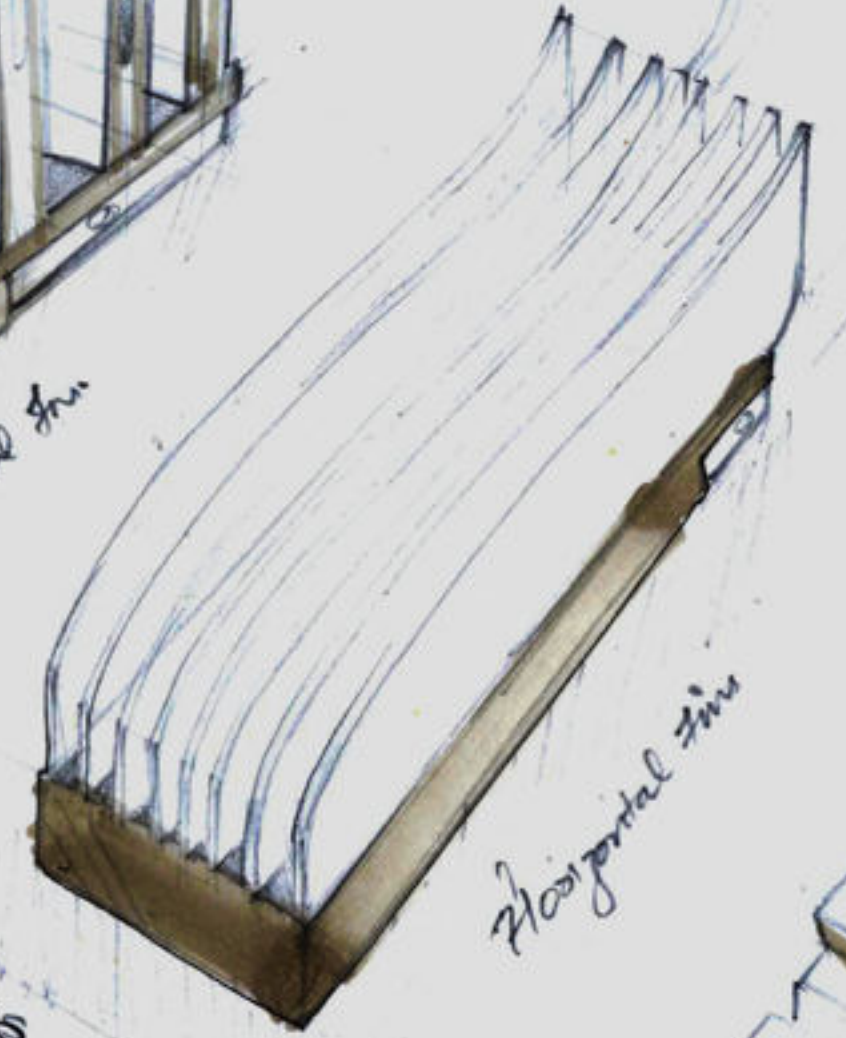
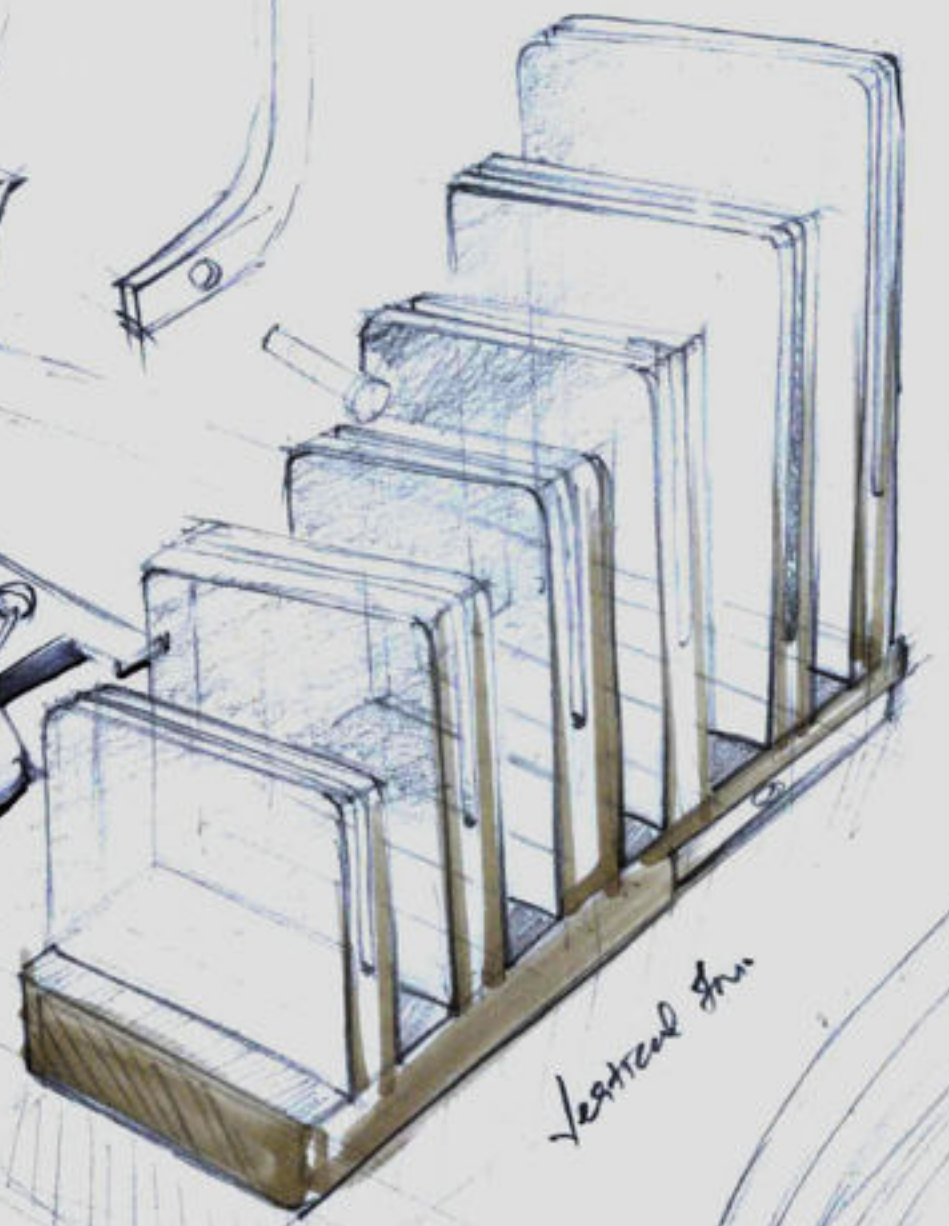
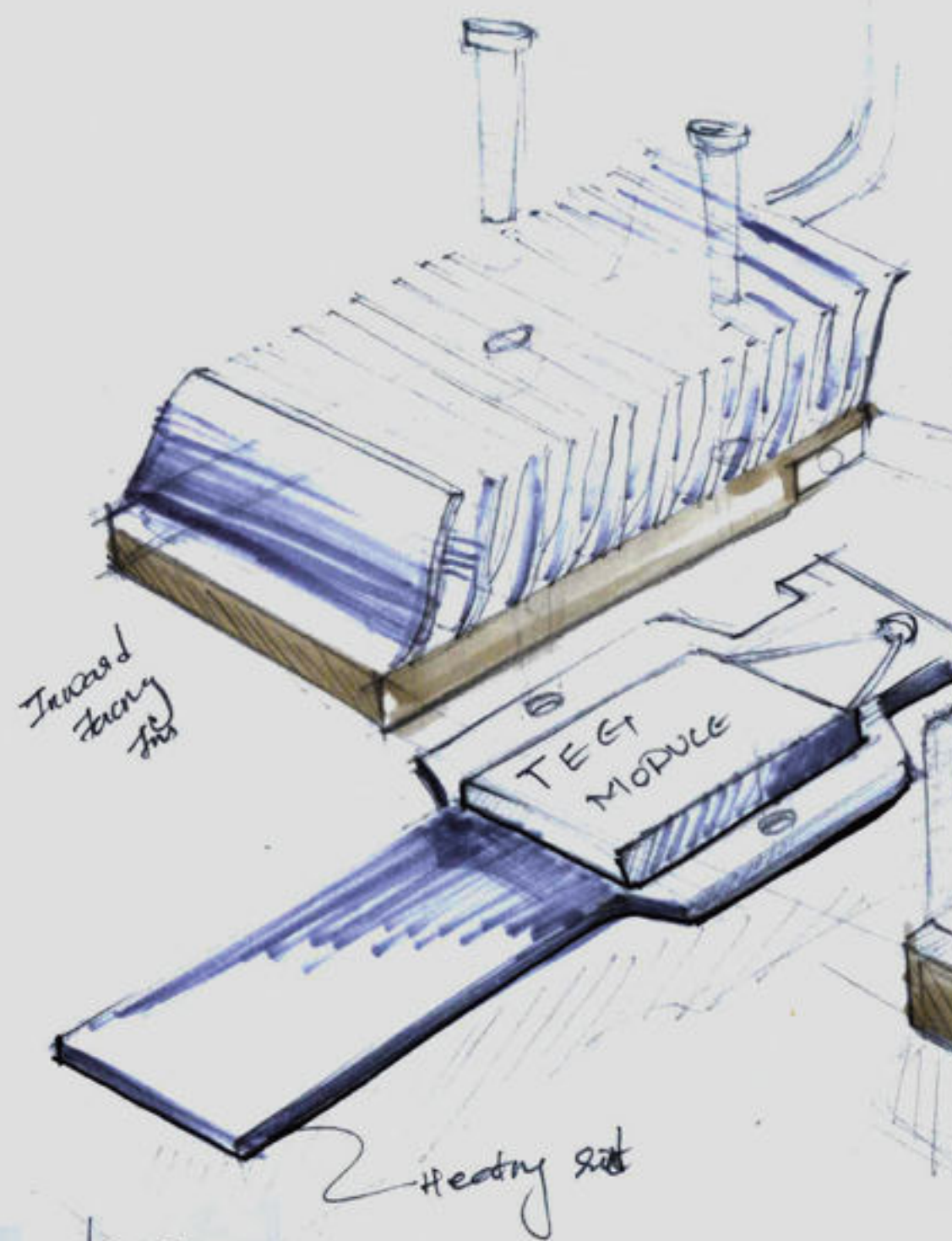

SHIT FINNERS

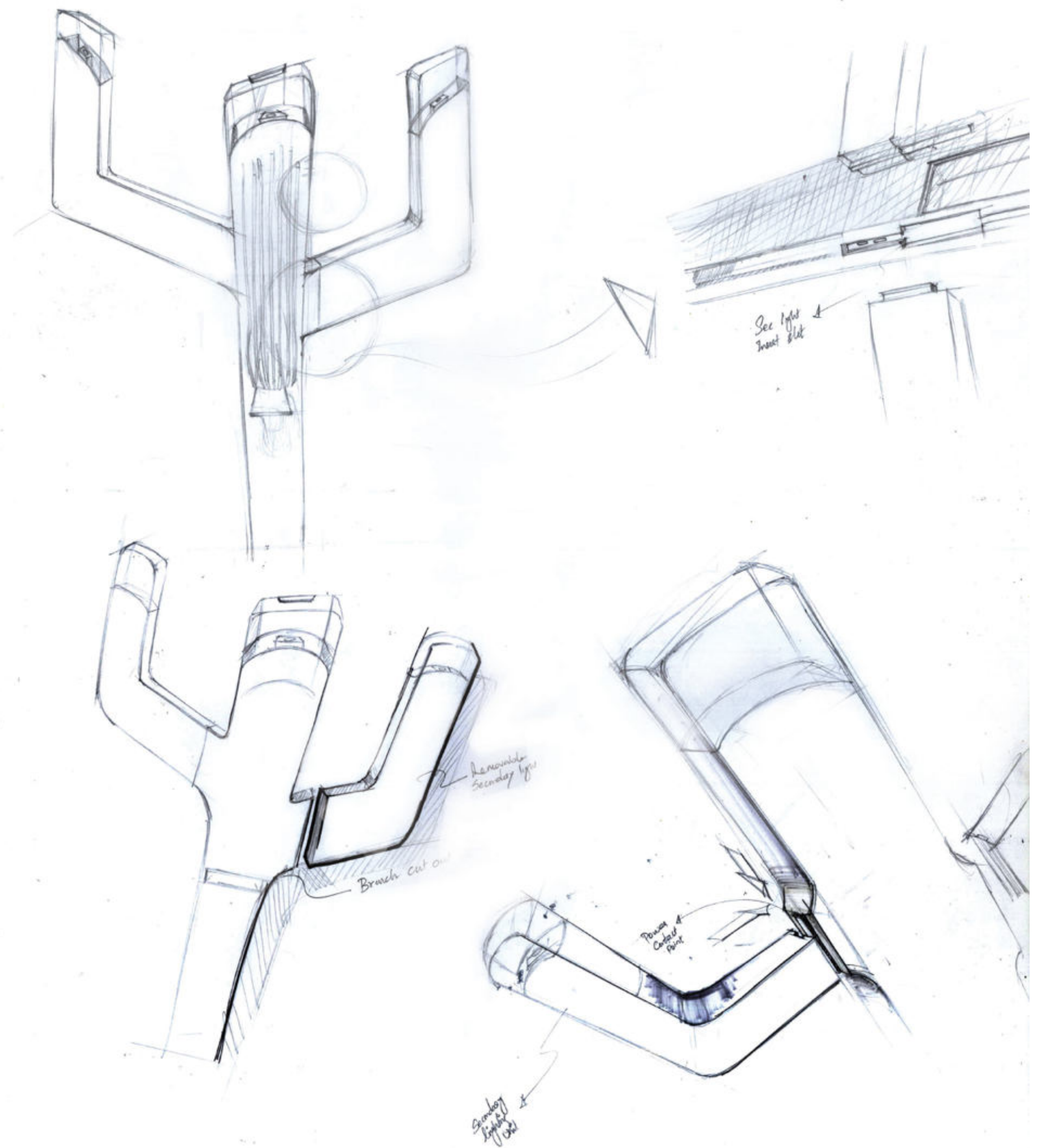
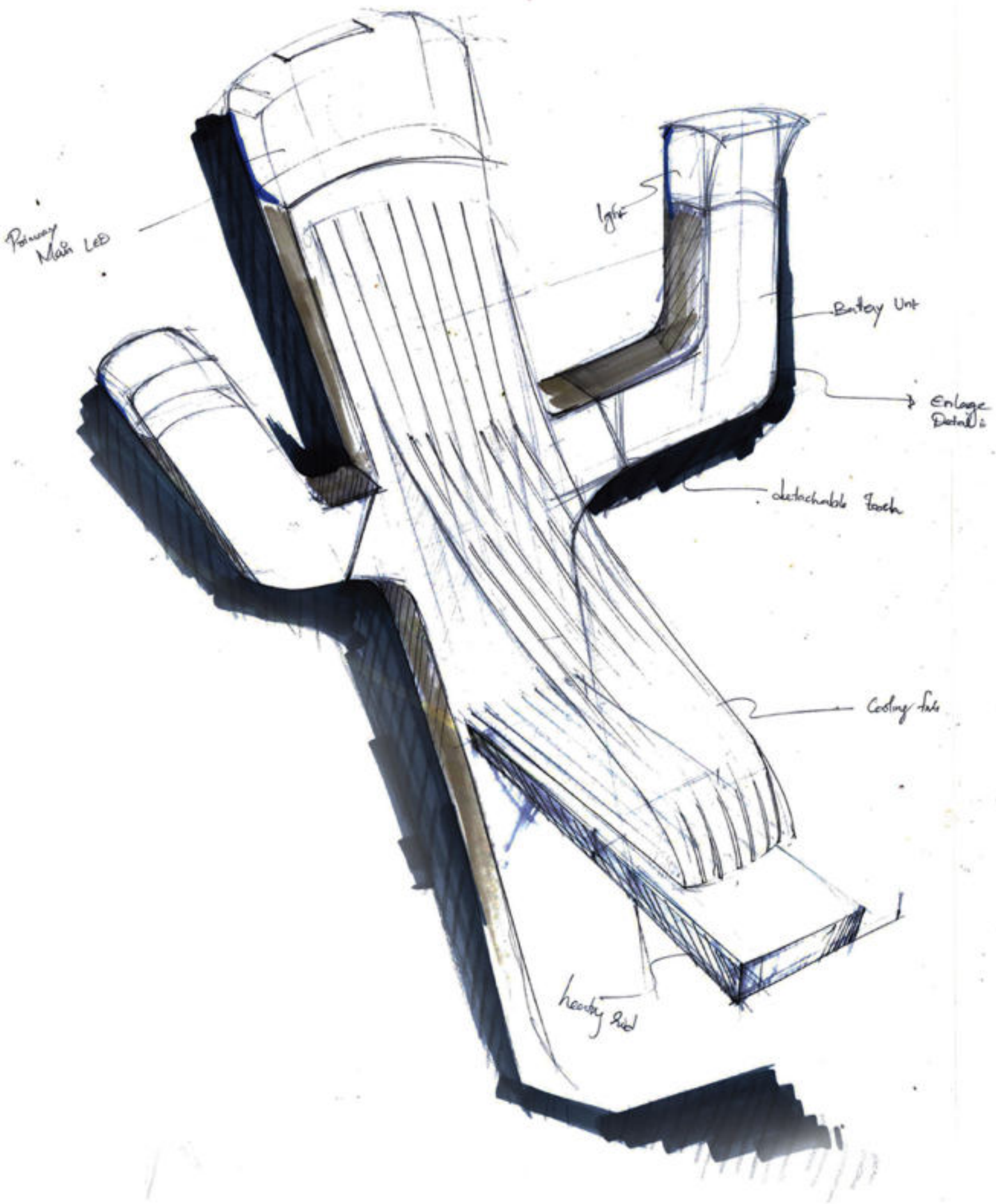

Study of
Test Rig



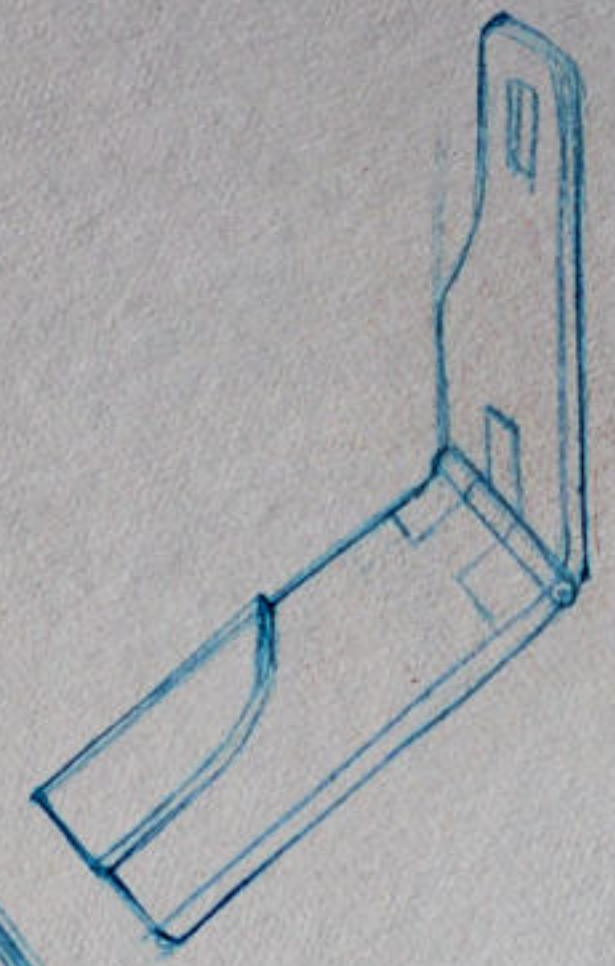
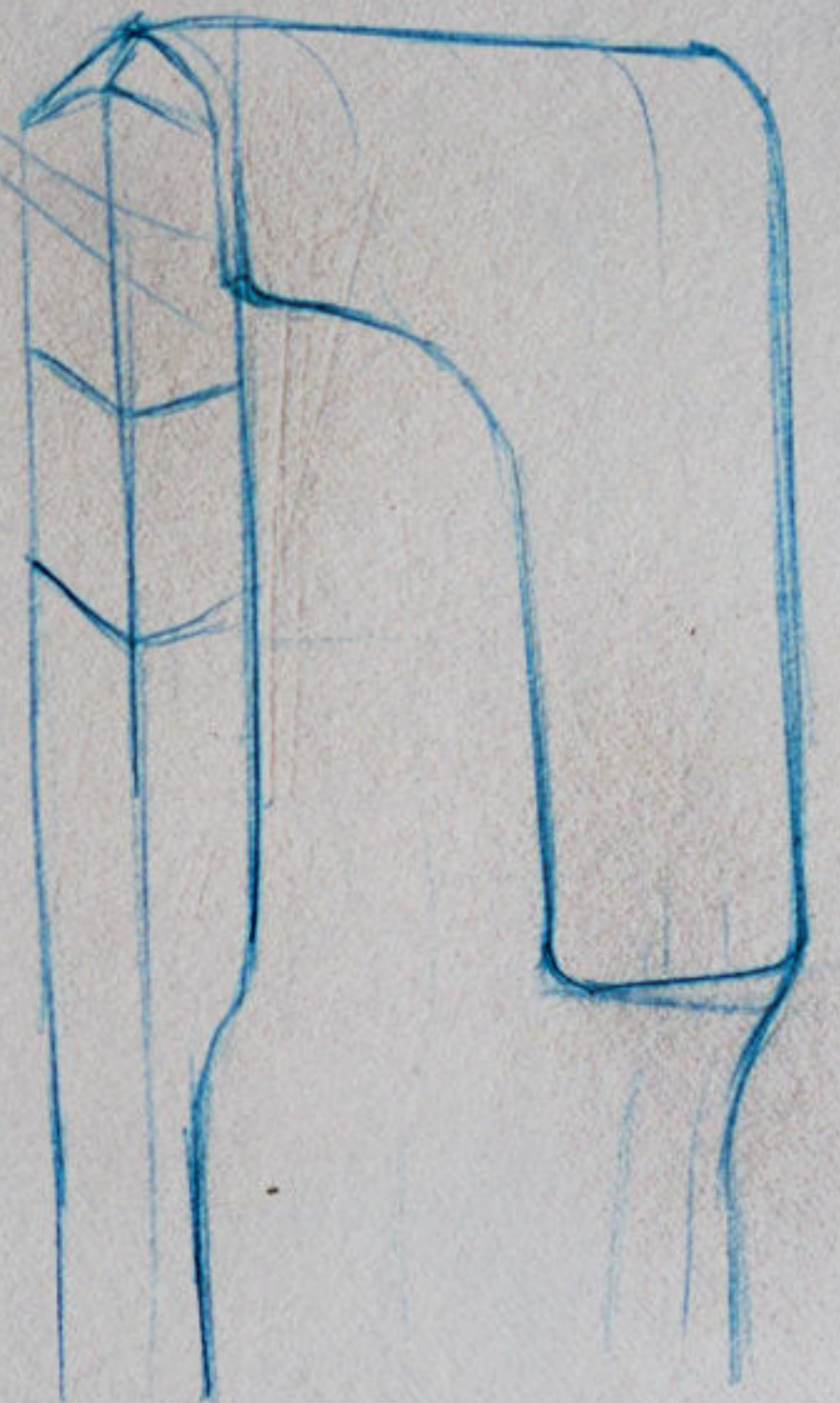
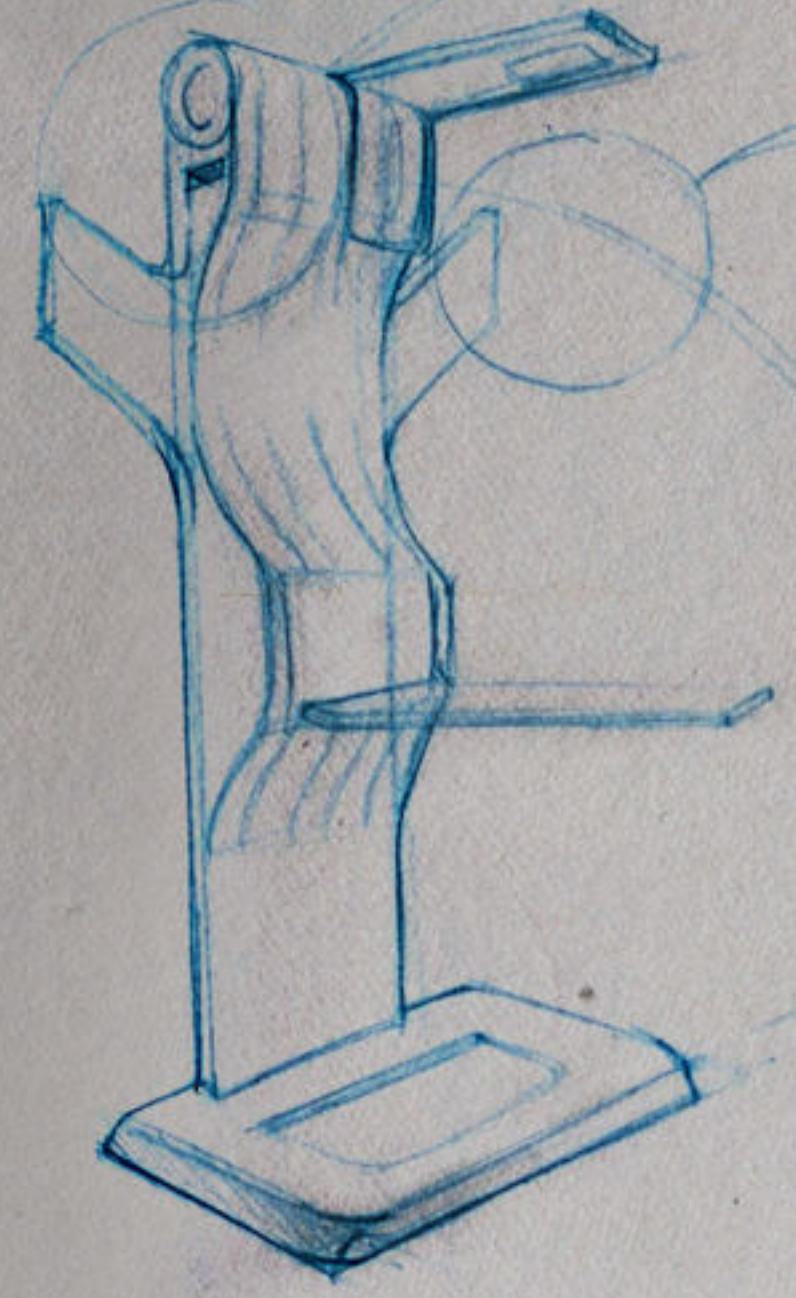
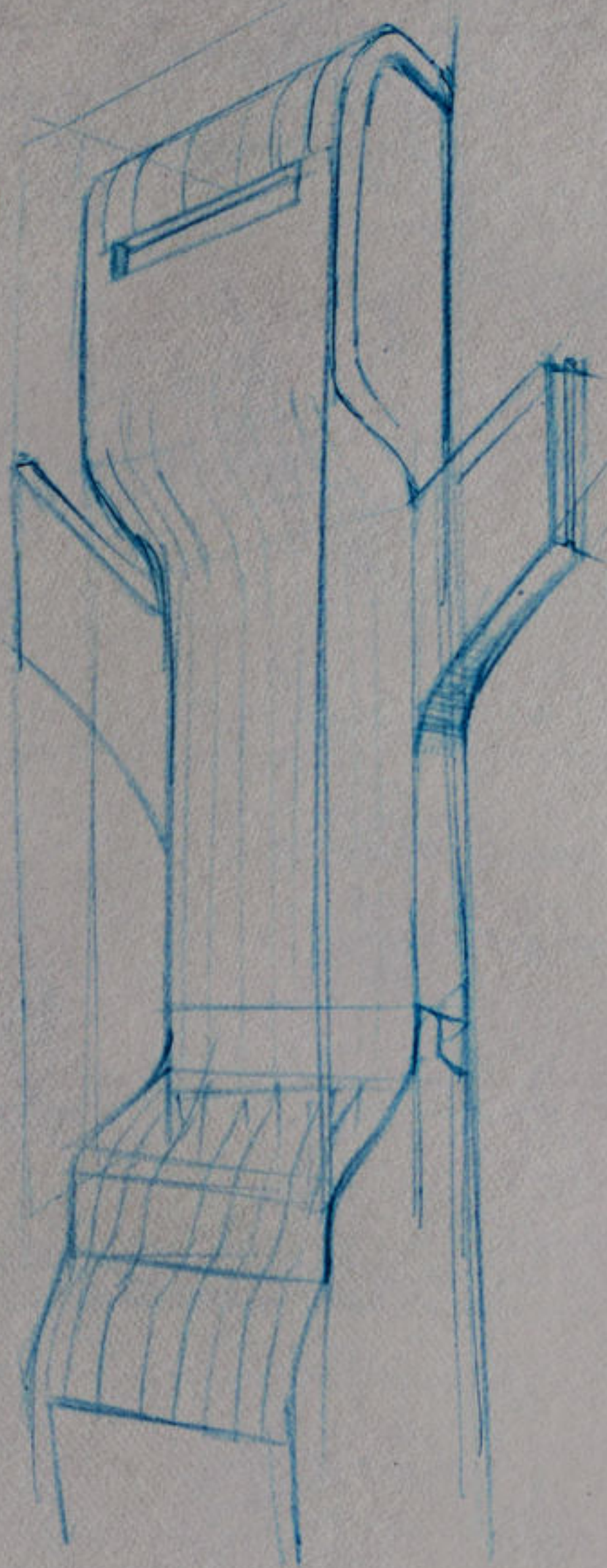
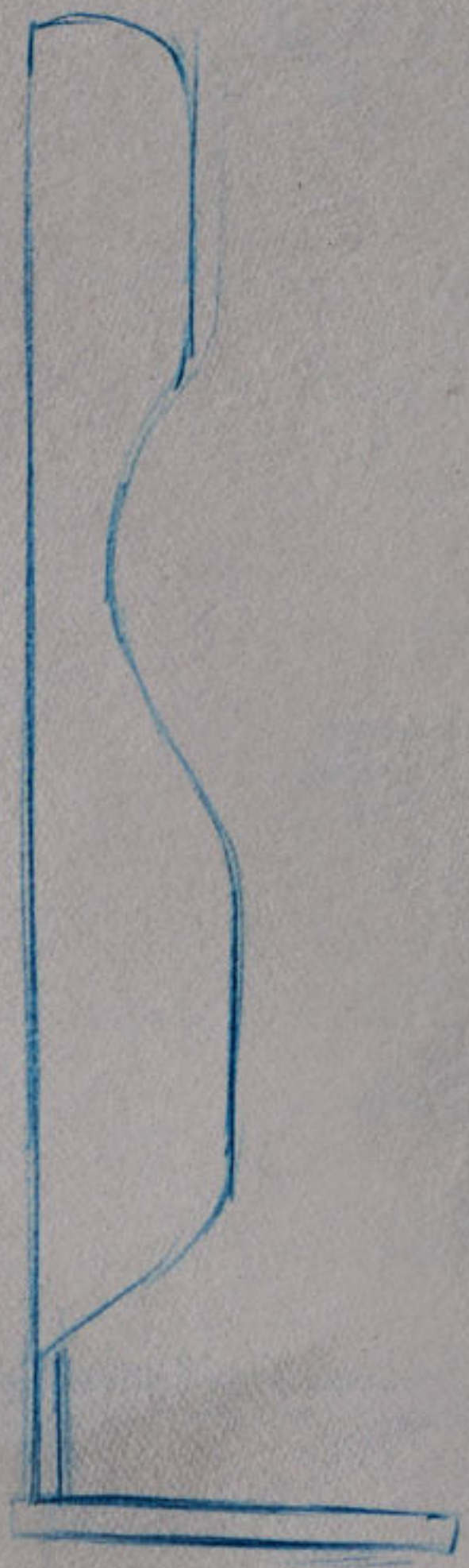

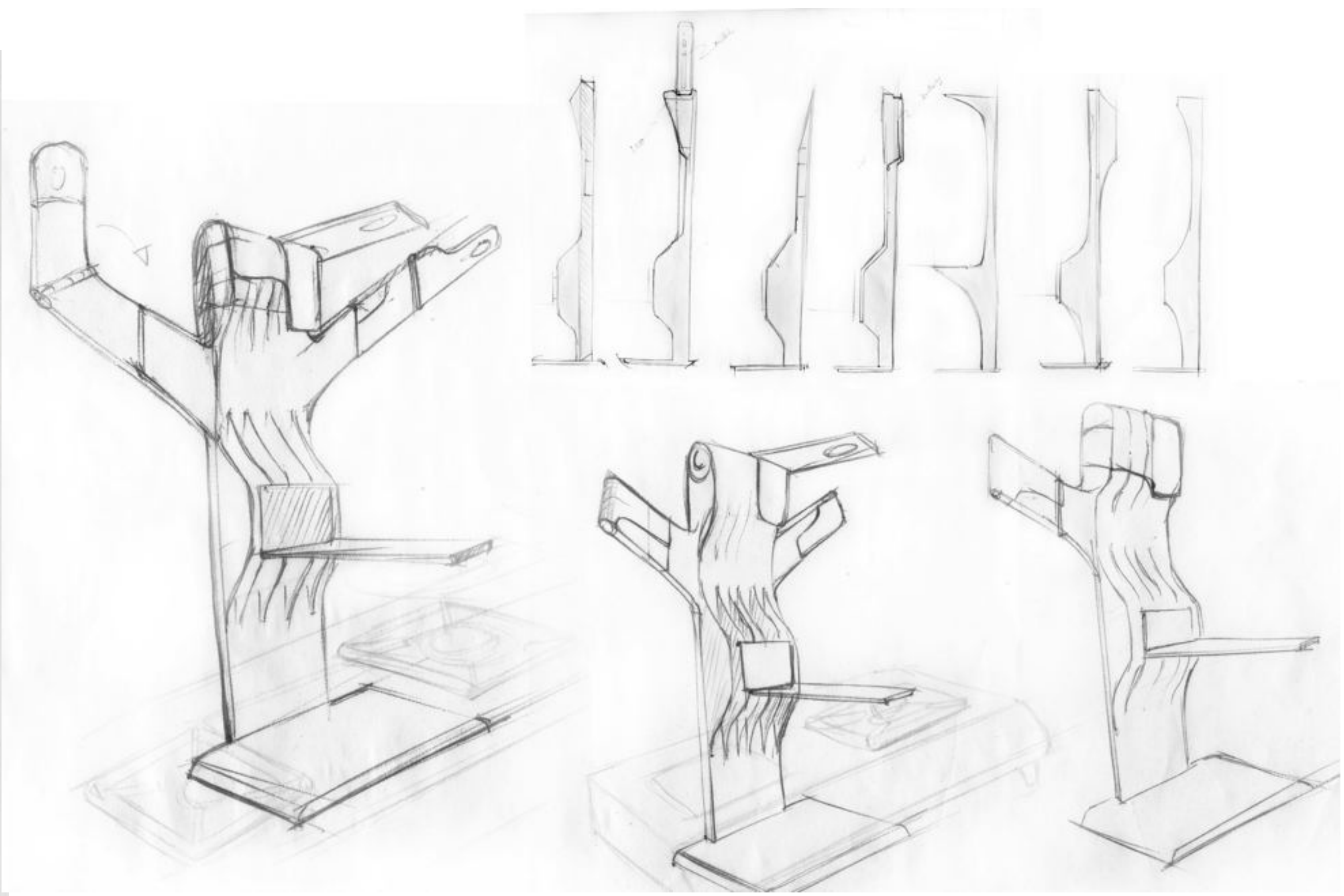
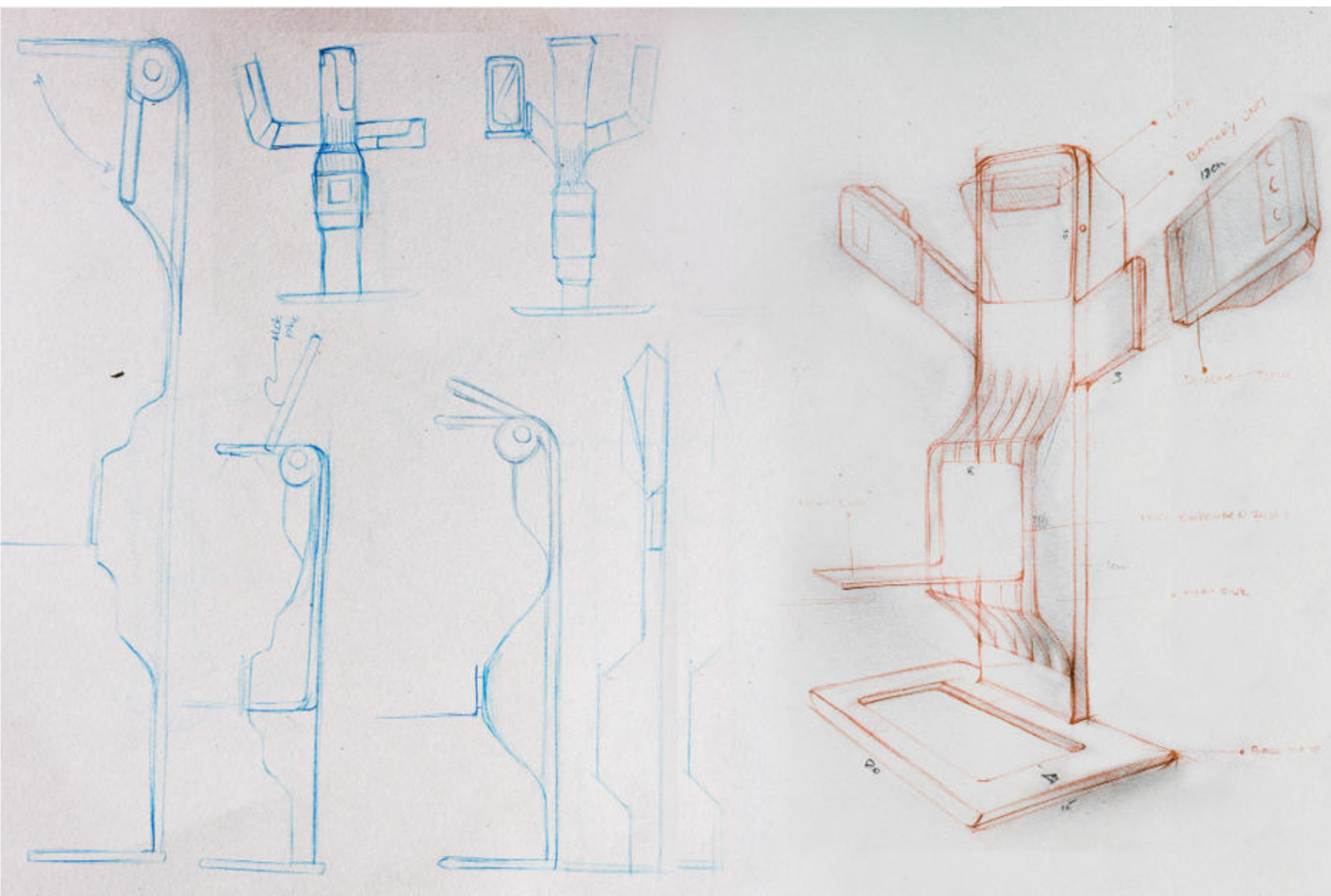

CAD

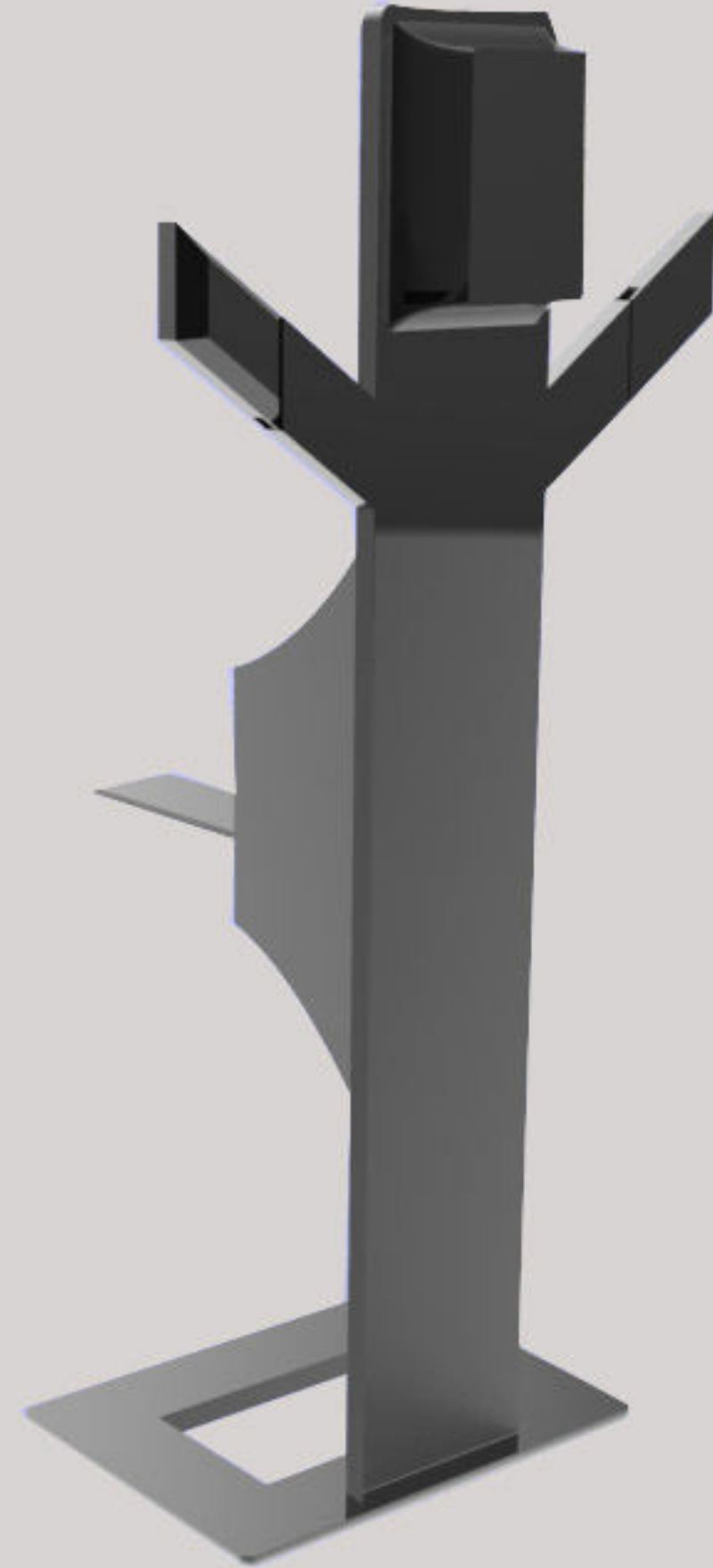
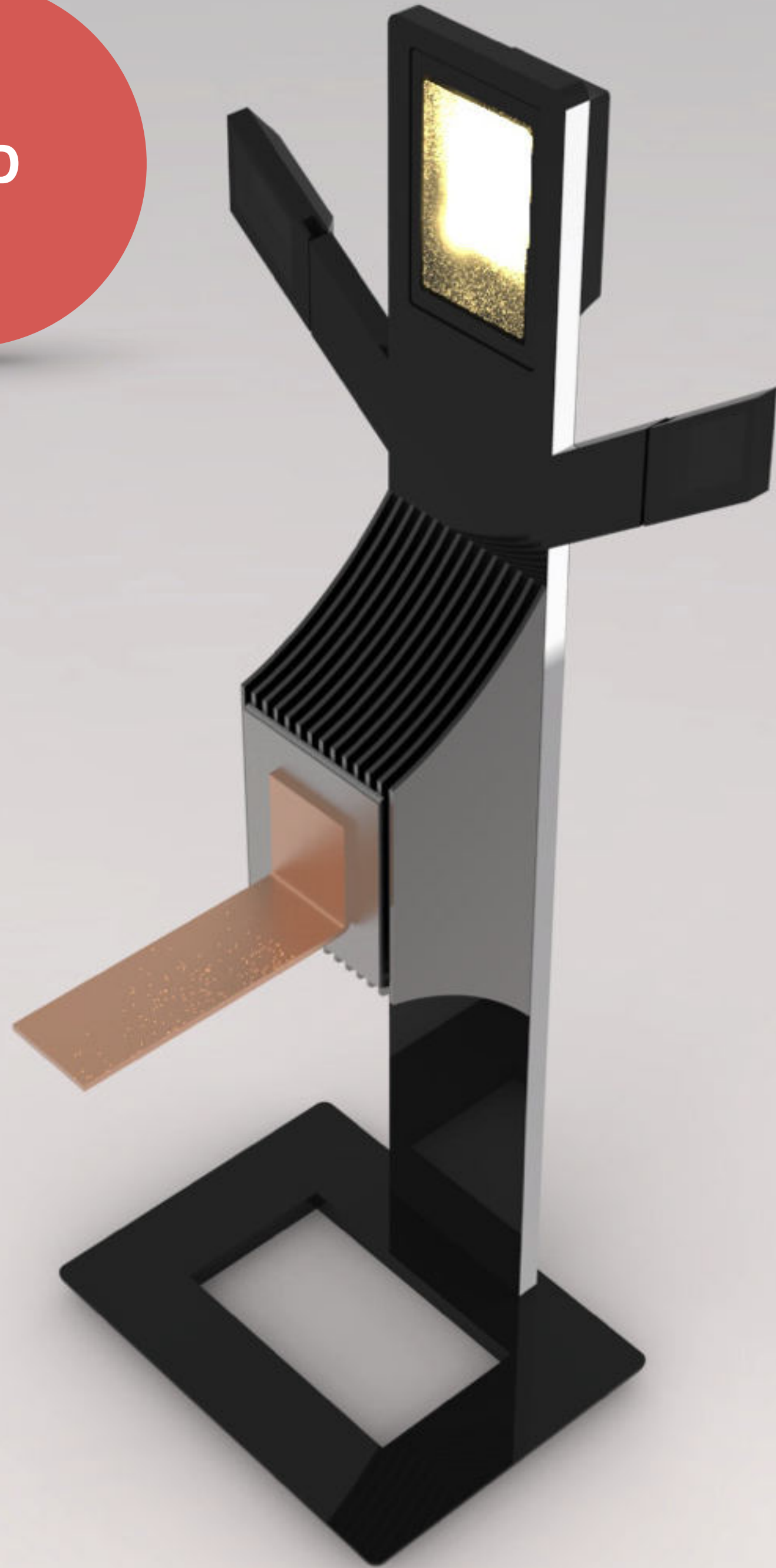

- The form helps to keep the device behind the stove.
 - The broad base and the battery behind the main structure helps to counter balance the weight of the heat sink.
 - The secondary light is detachable and can be used as torch.
- The isometric back view

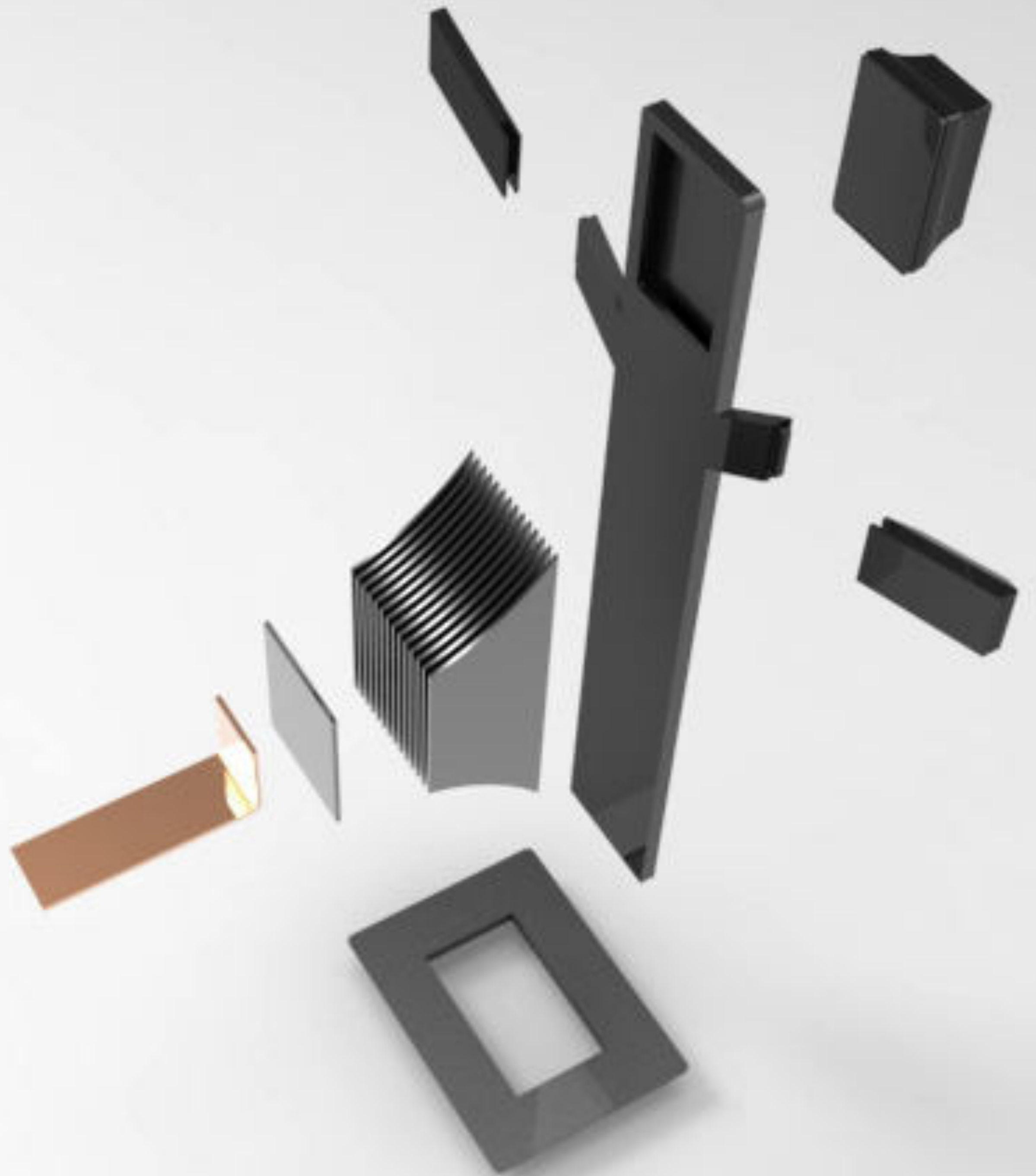
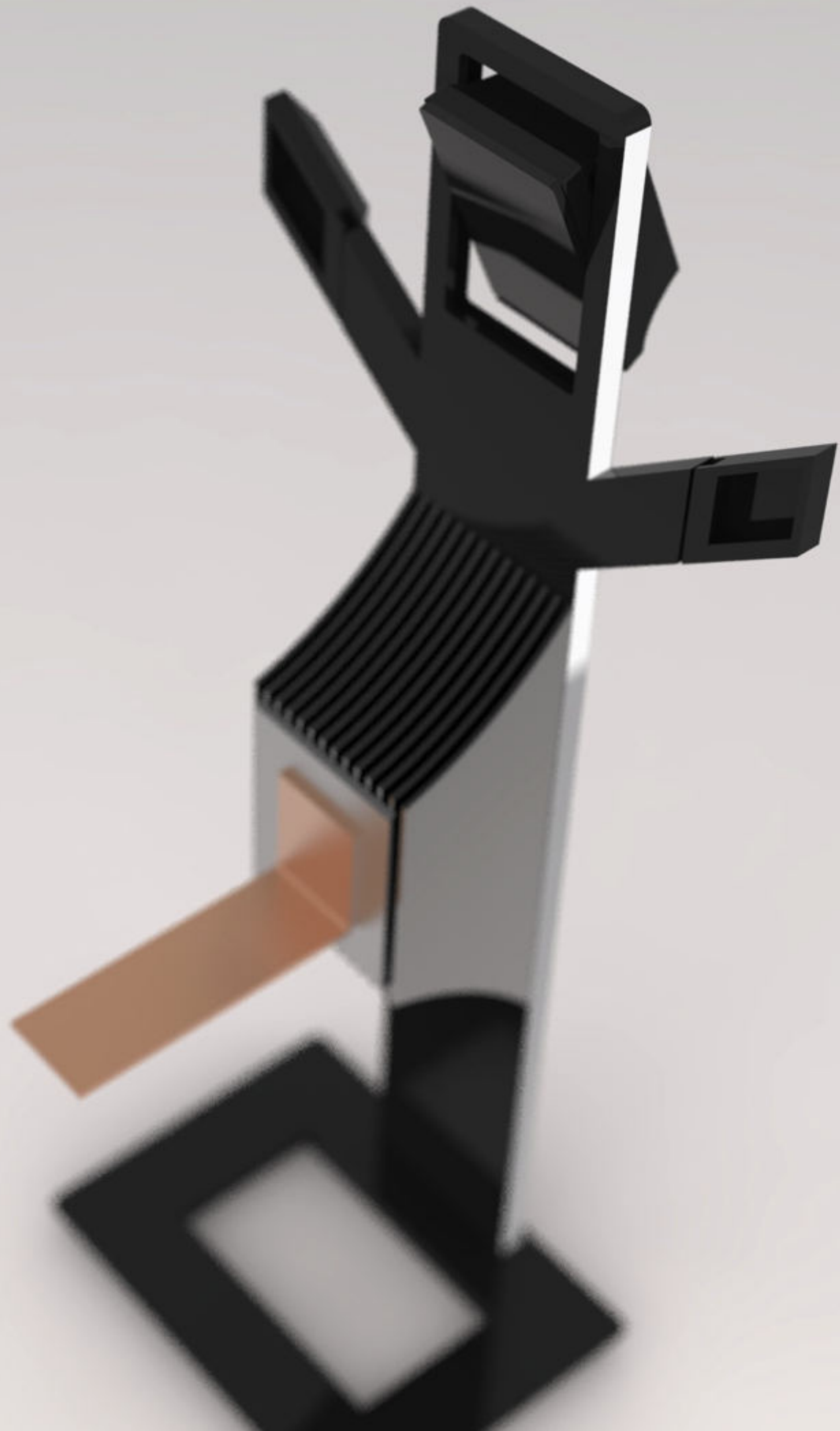

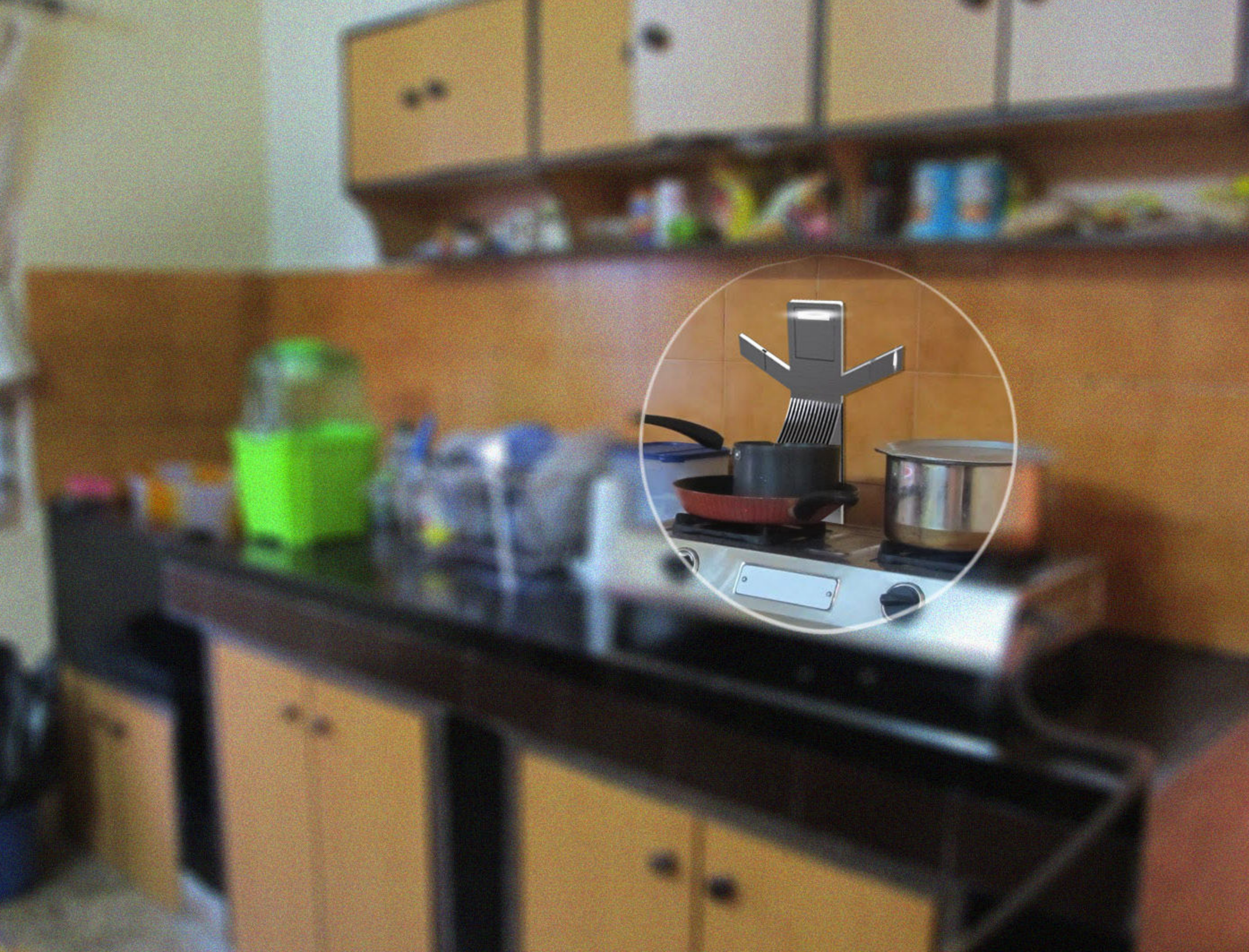

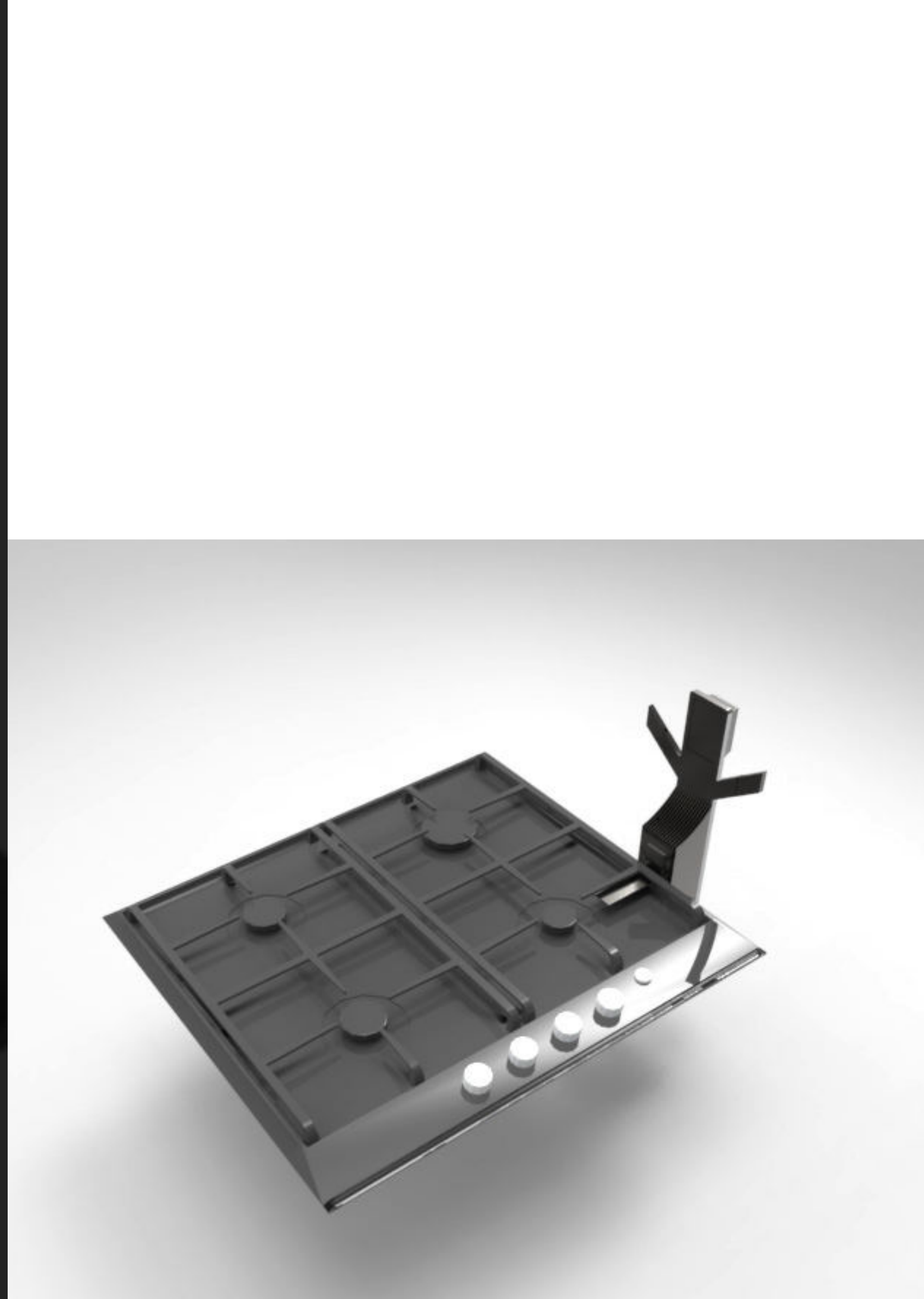
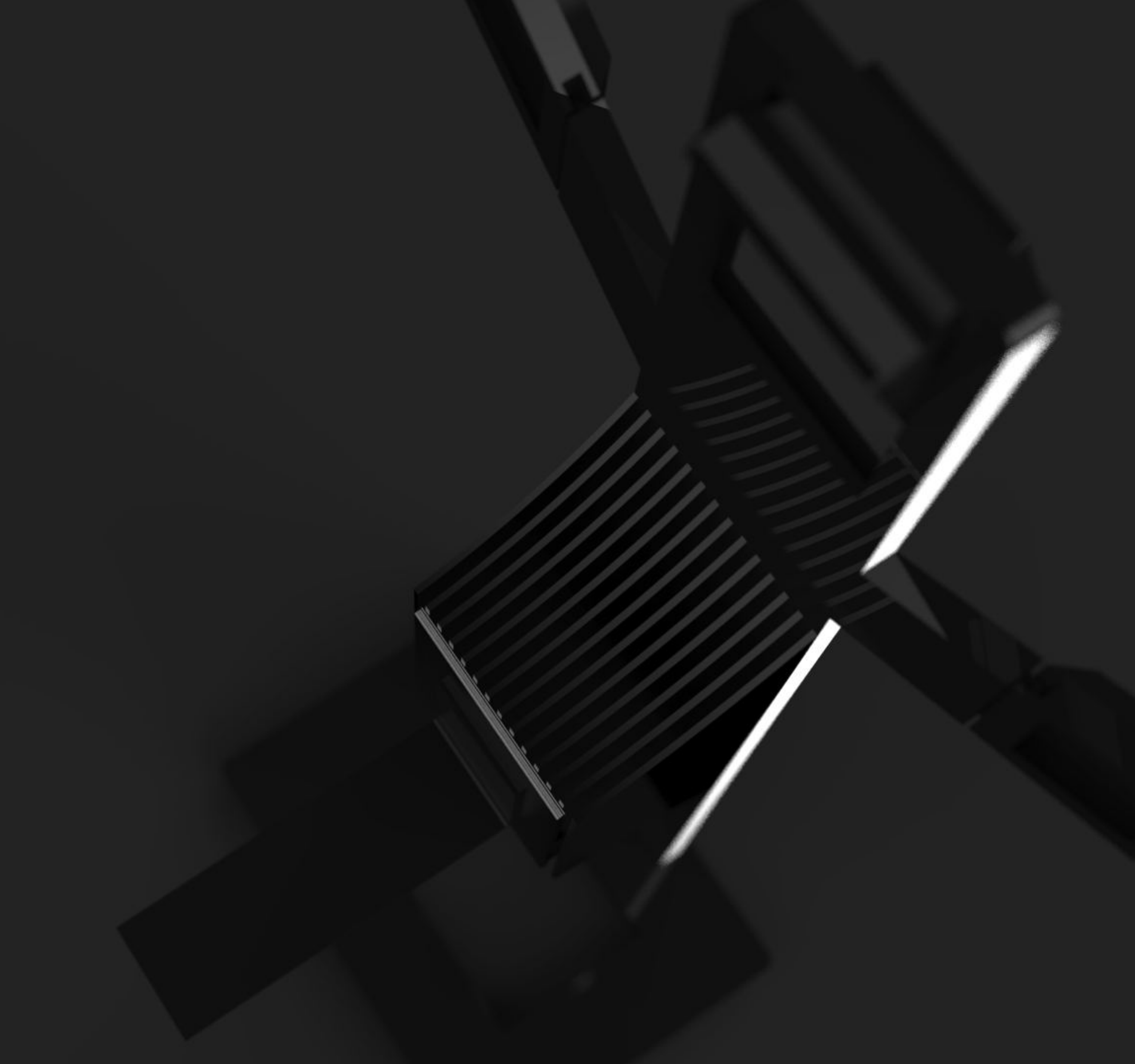

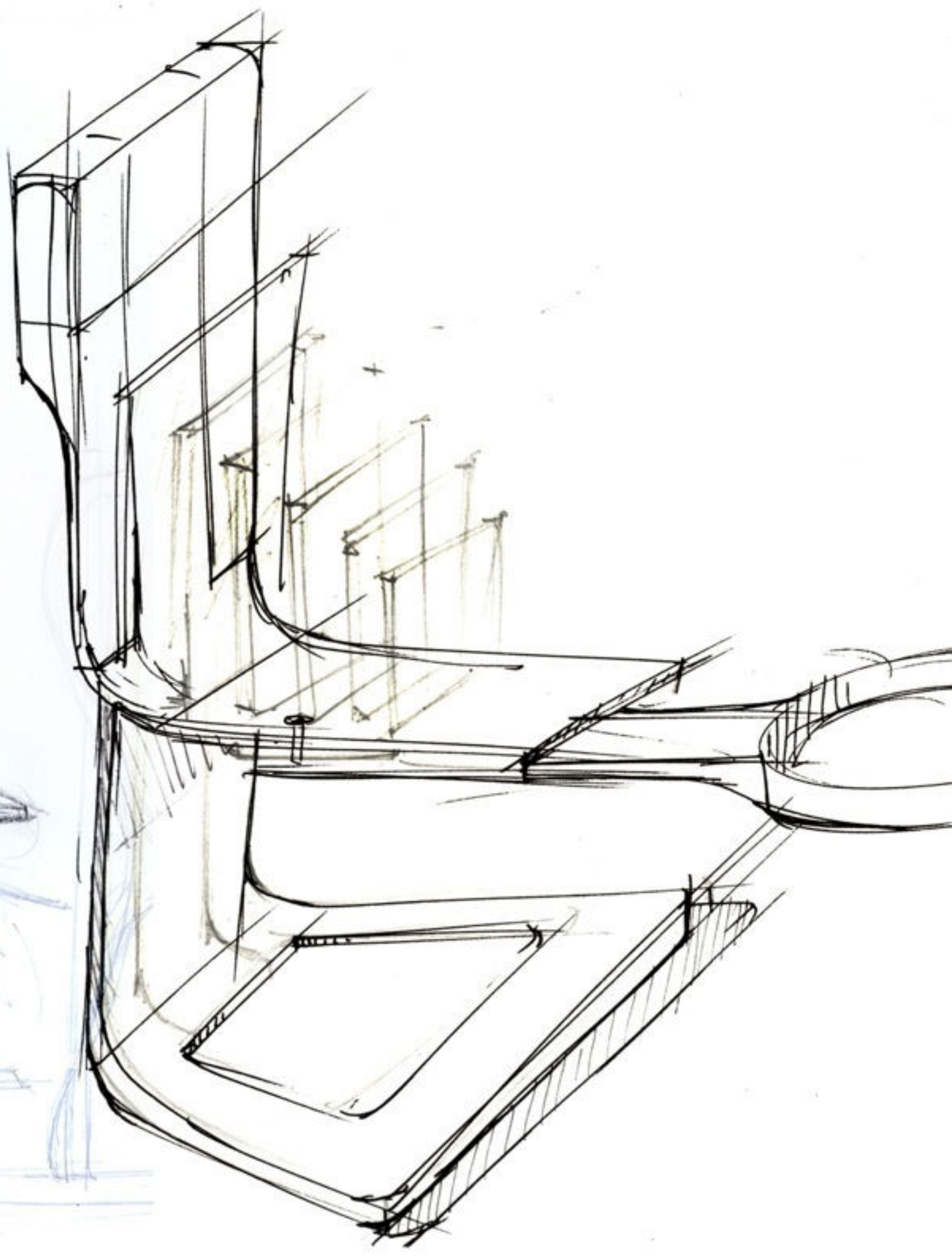
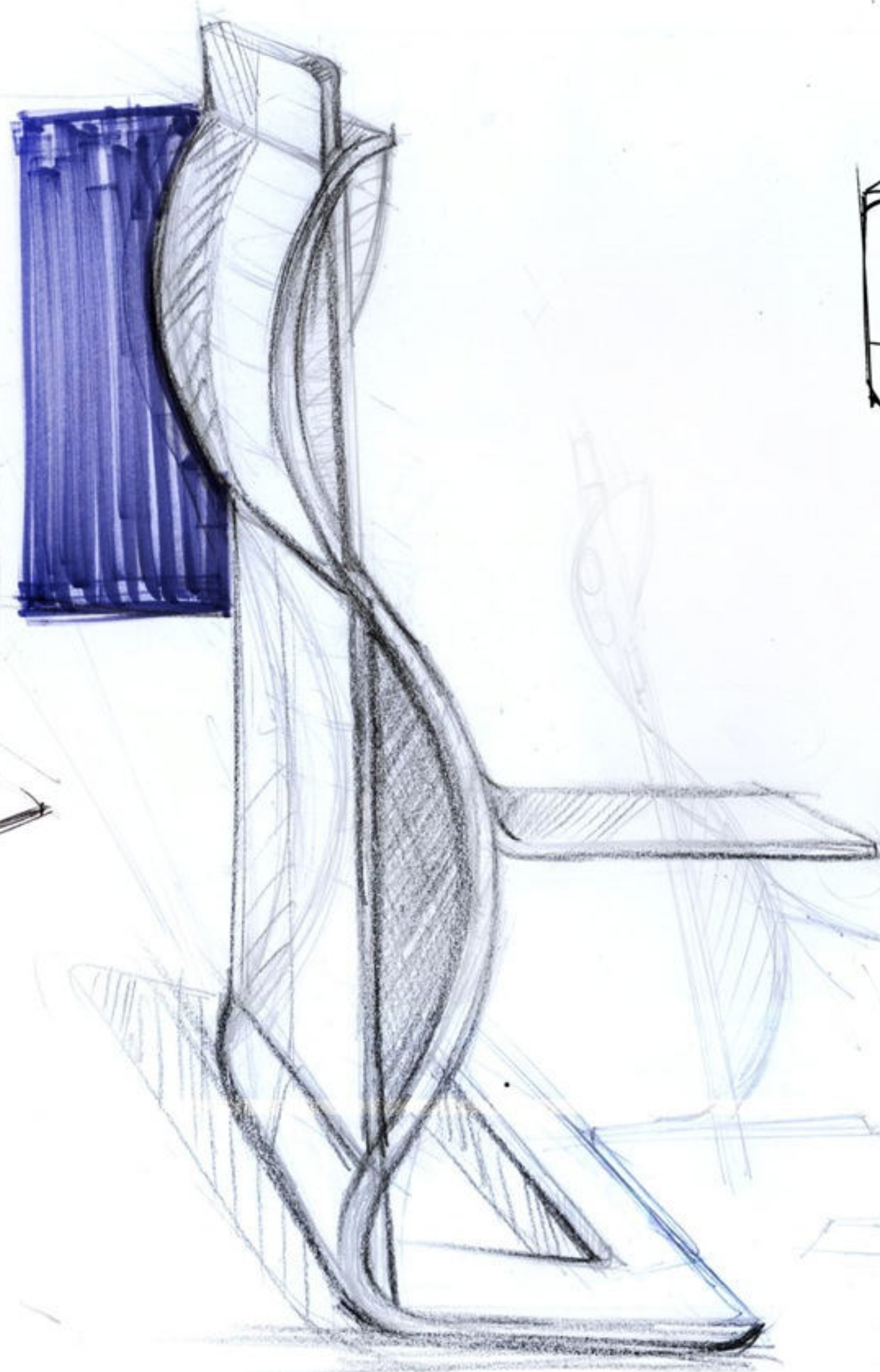
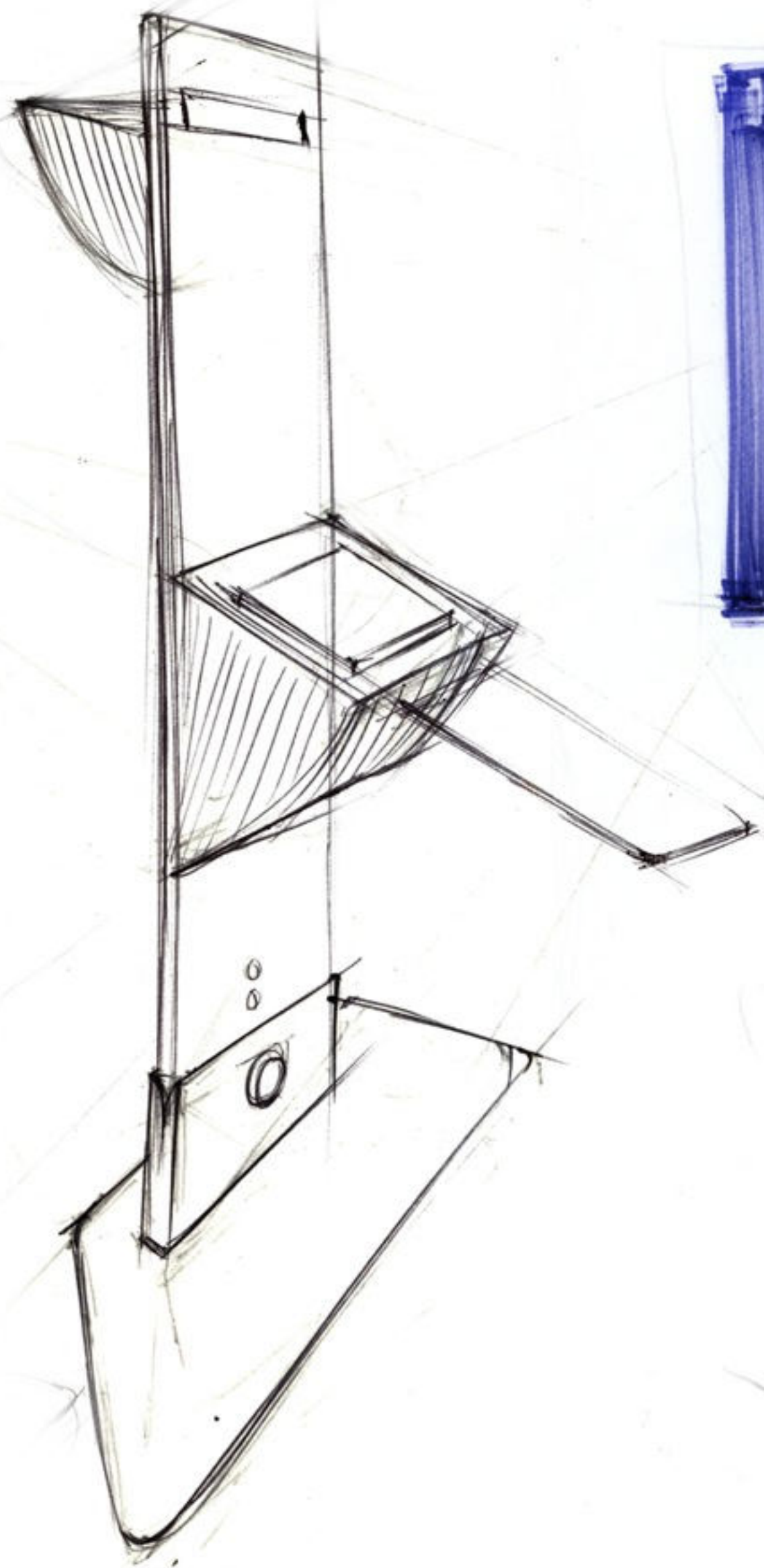
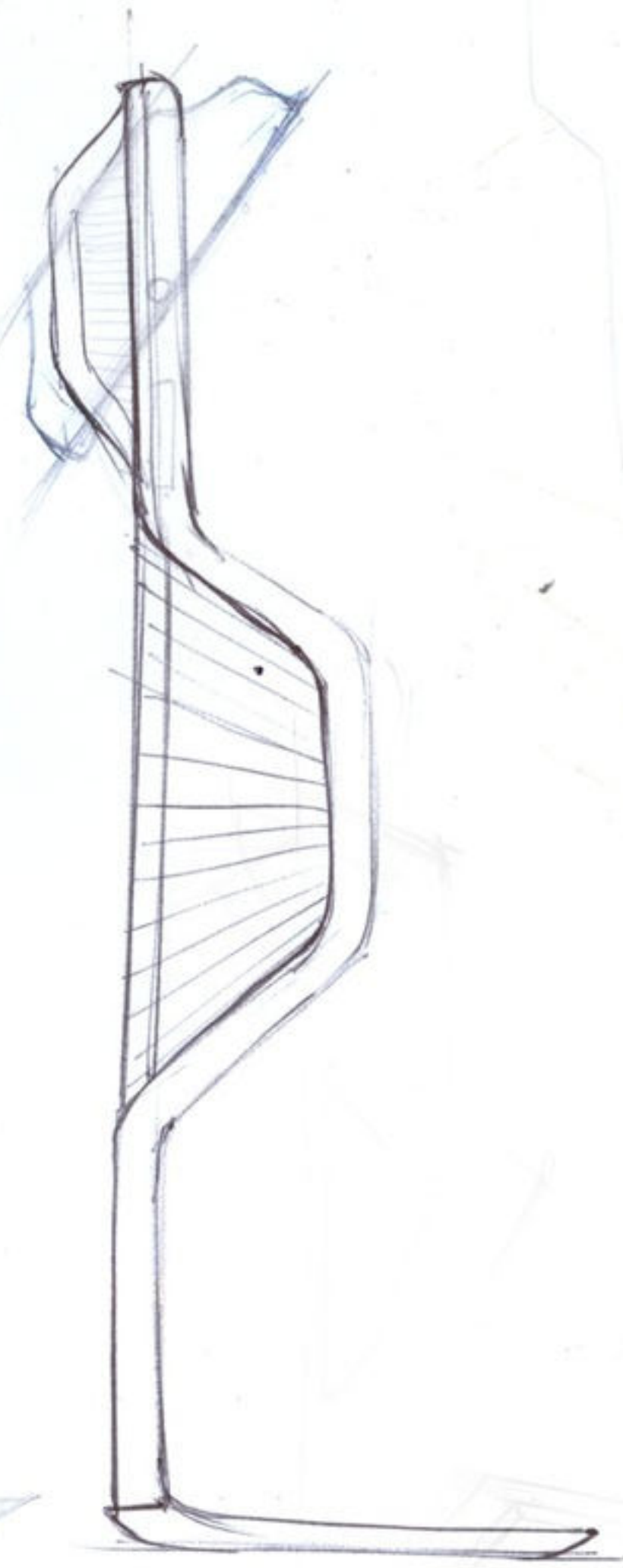

Options and analysis

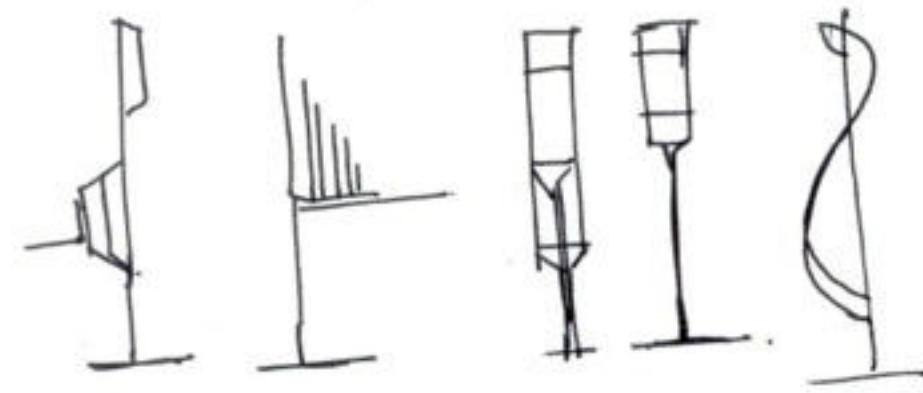

- Stroke adjust
- Wire management
- Circuit
- Switch
- Stroke to G Attachment

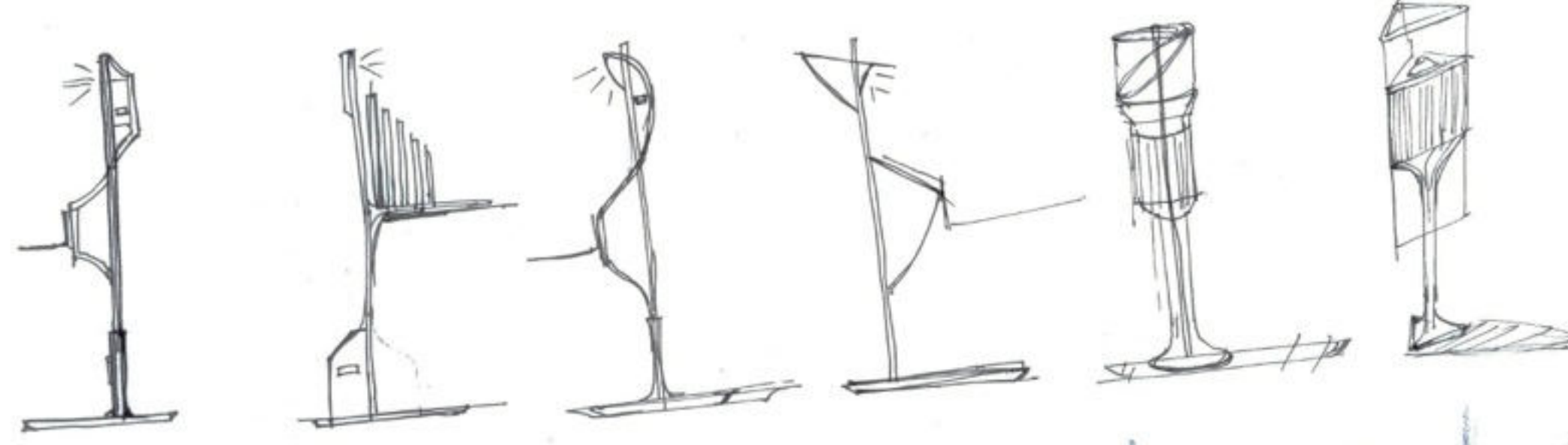

LIGHT

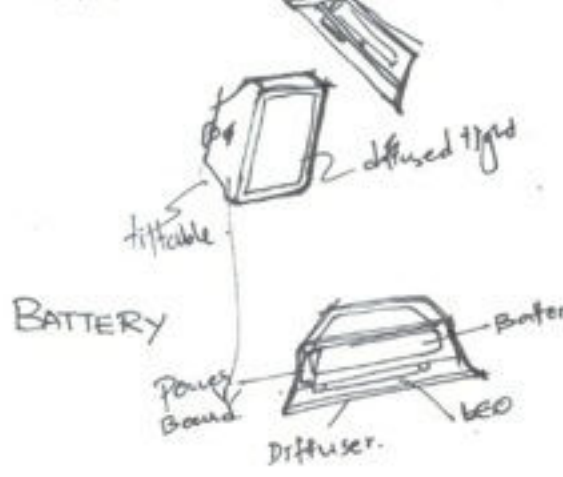

HEIGHT ADJUSTMENT

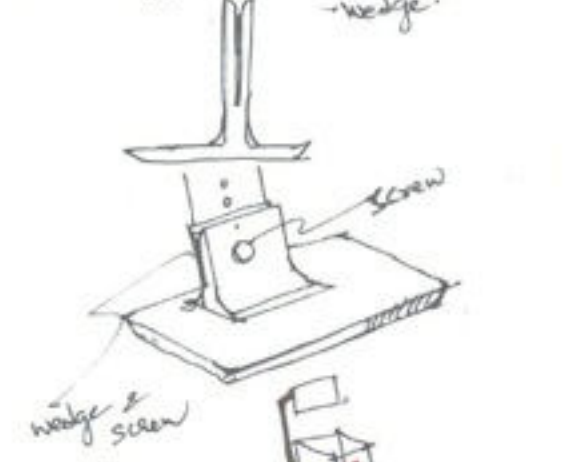

BASE & WIRING



SWITCH & CHARGING PORT

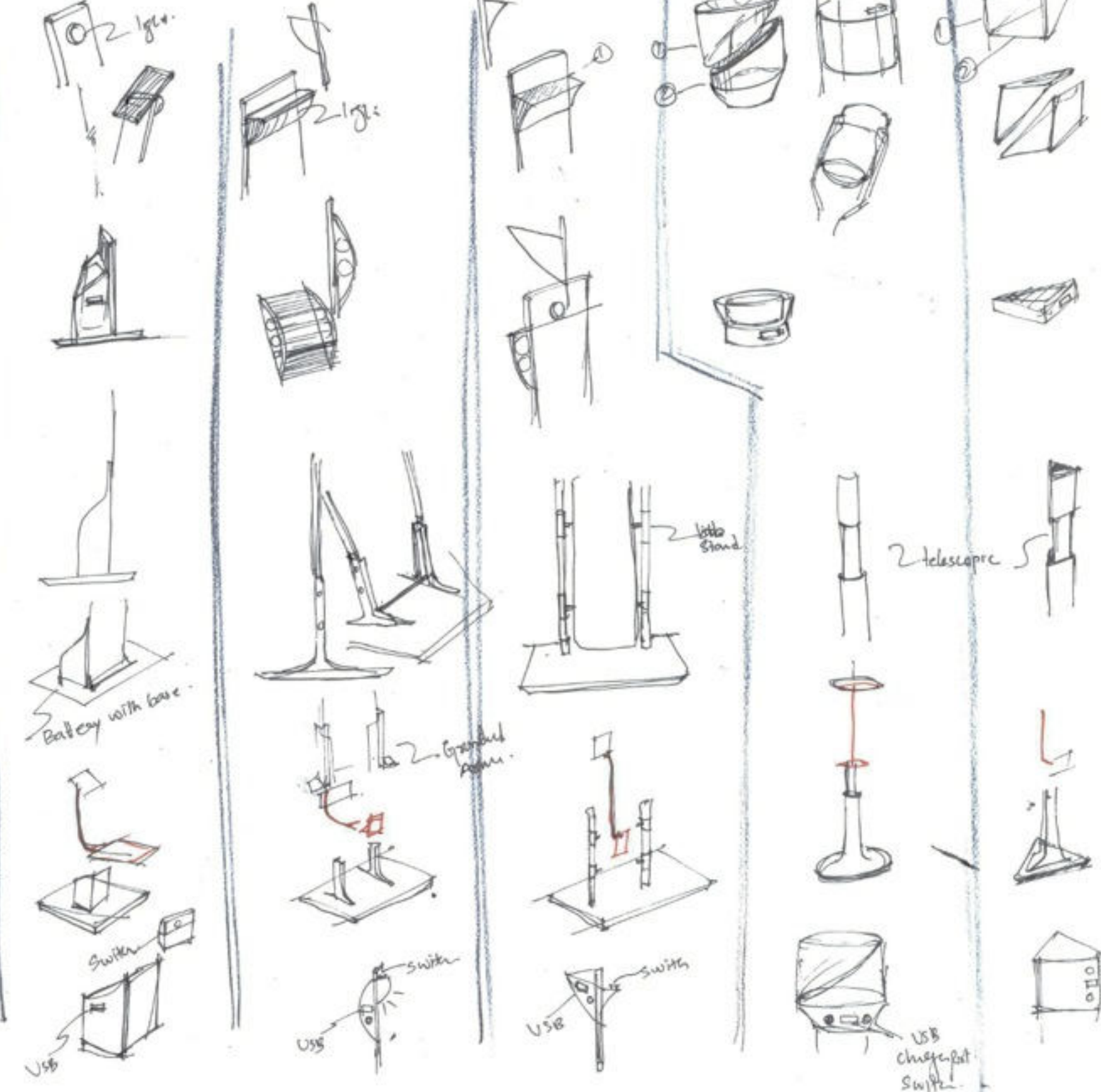

2 telescopic

USB charge-port switch

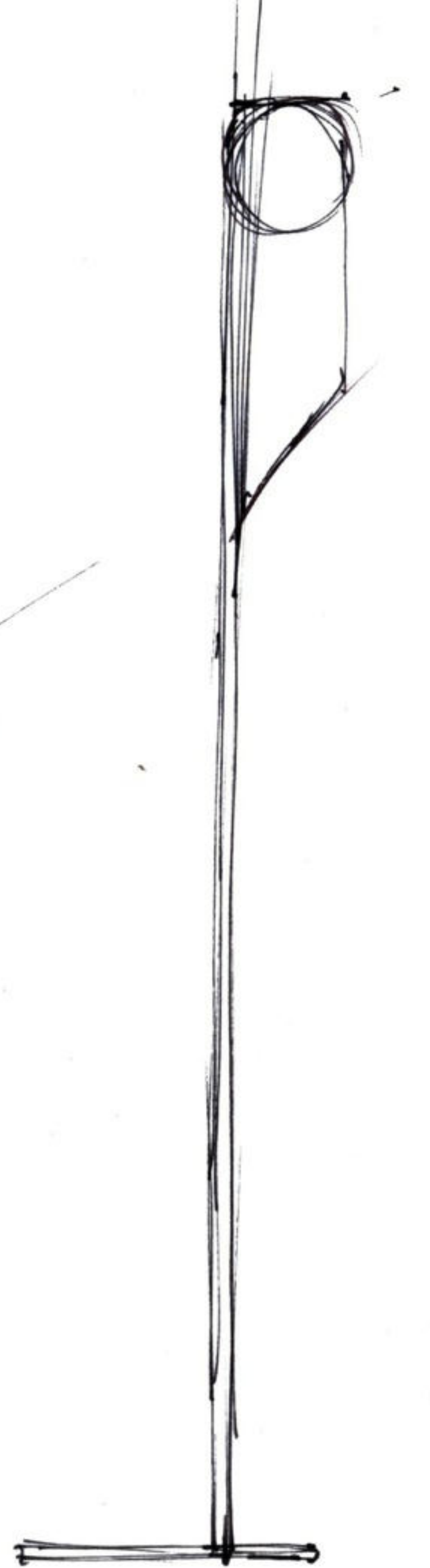
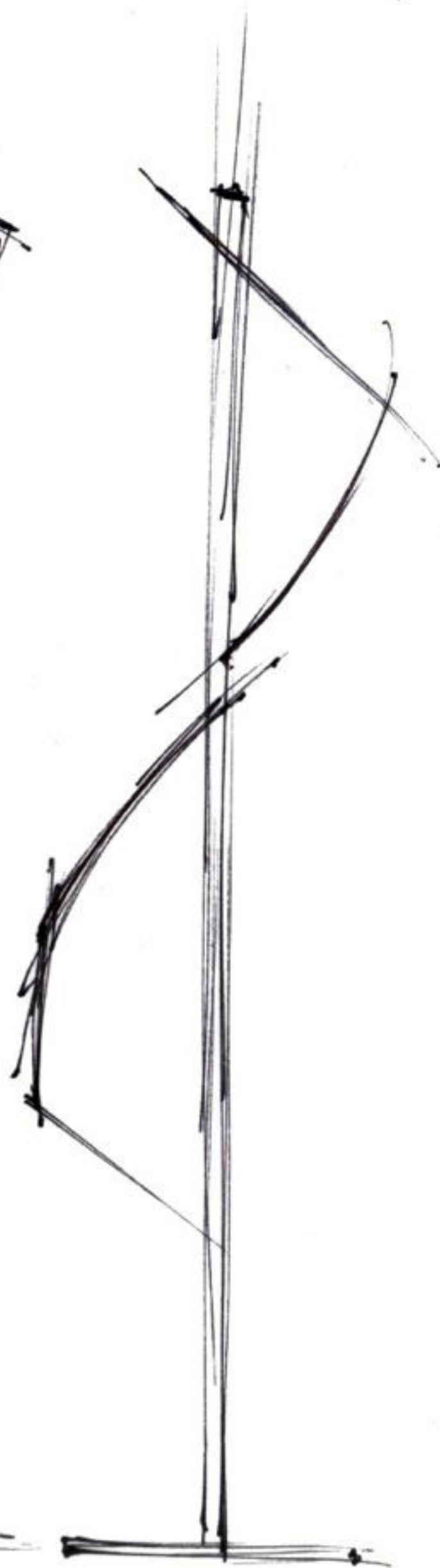
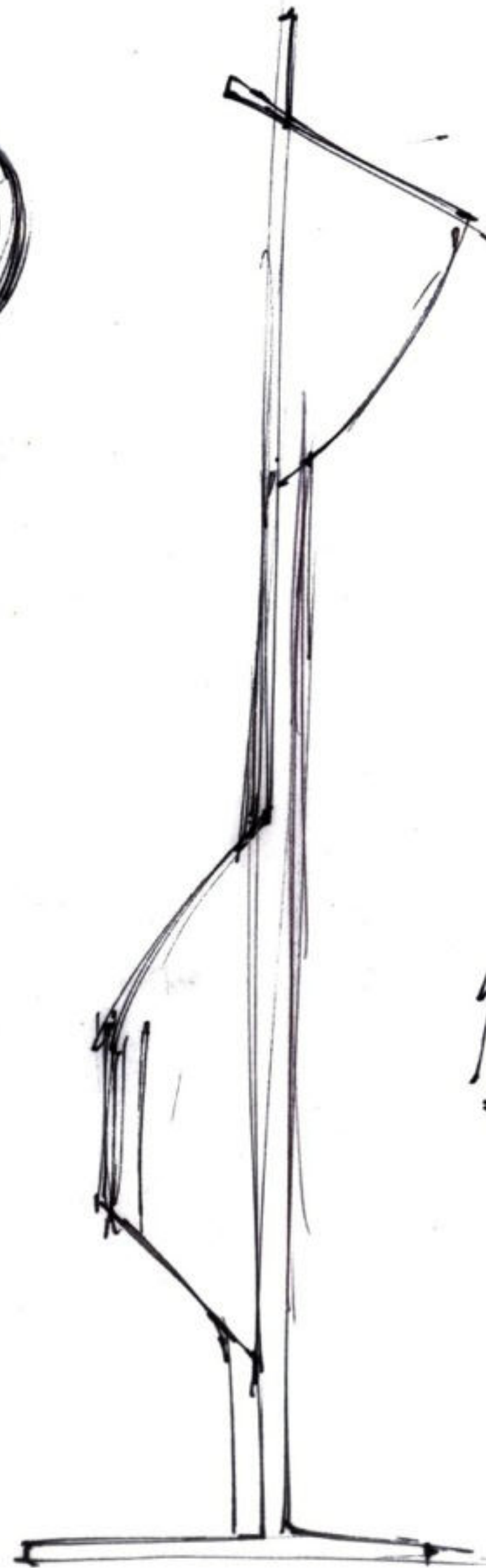
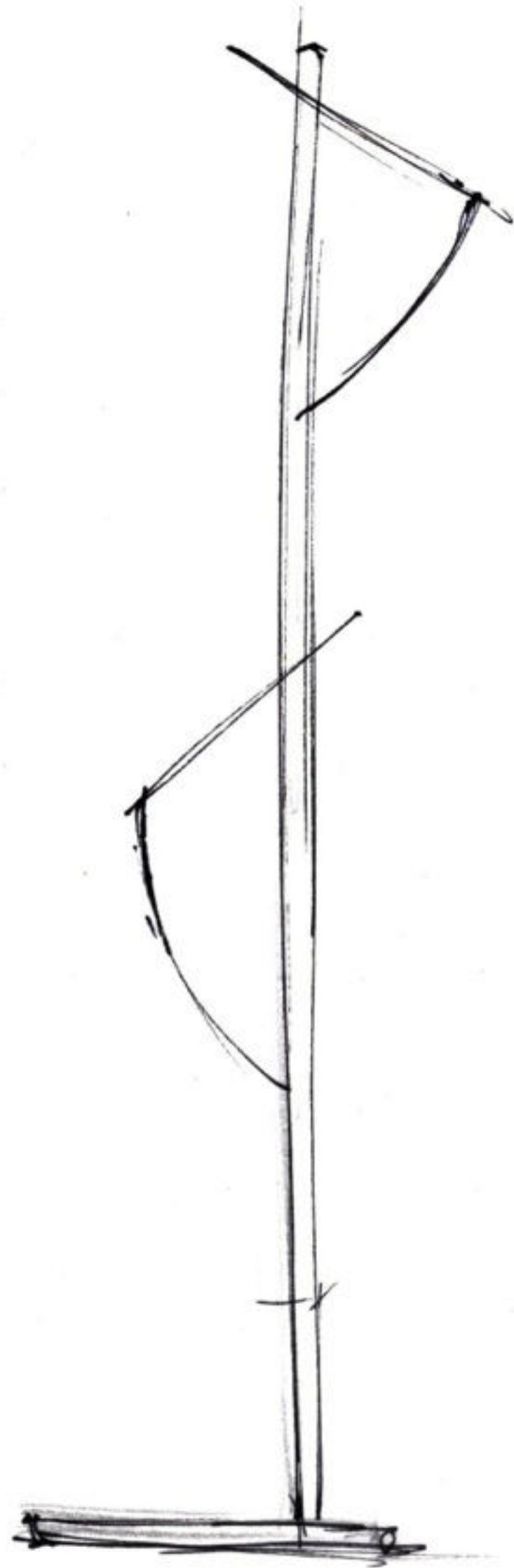
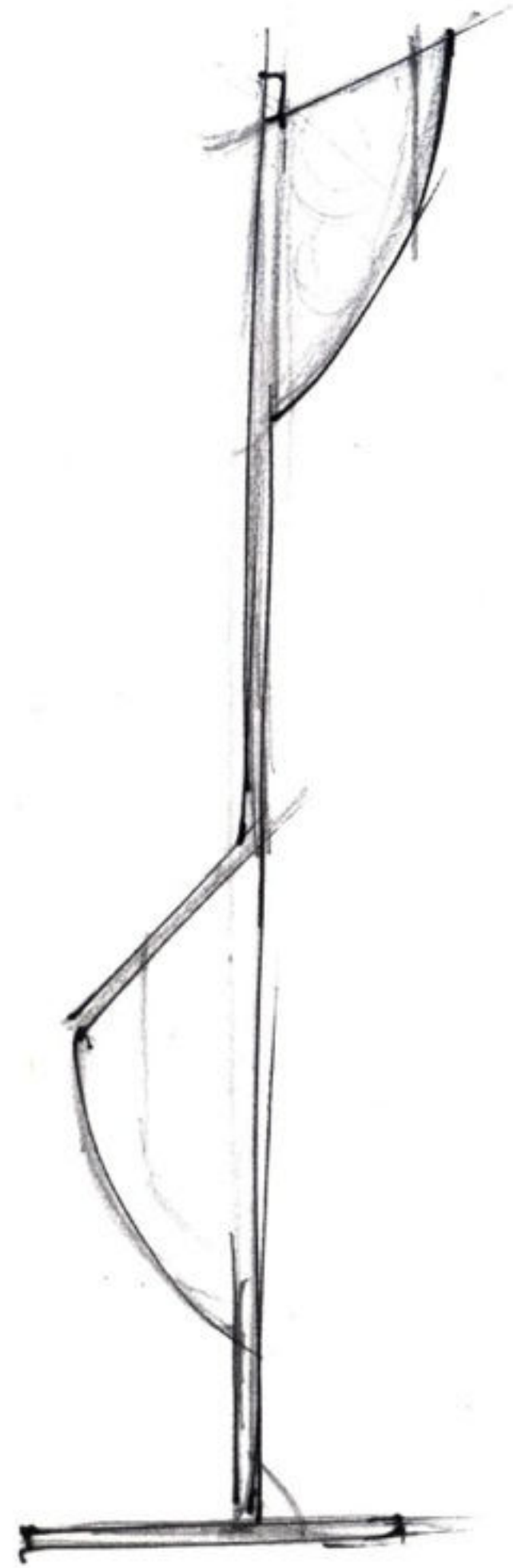

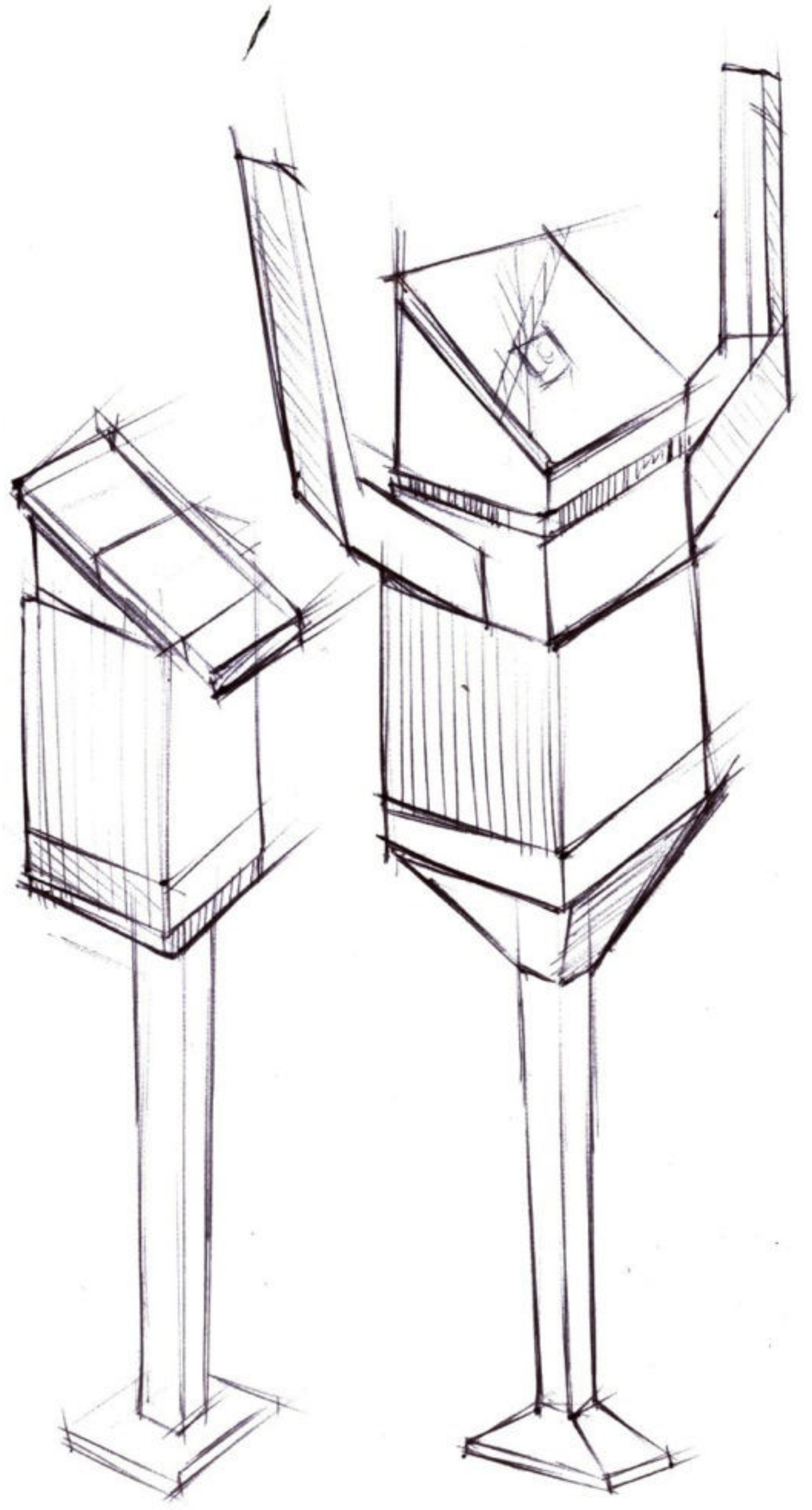
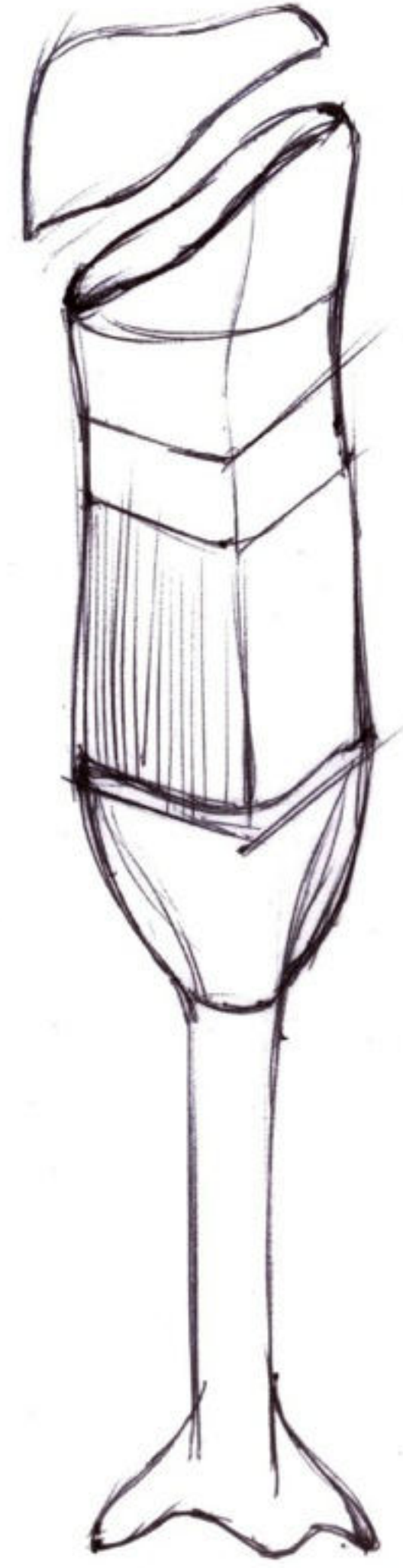
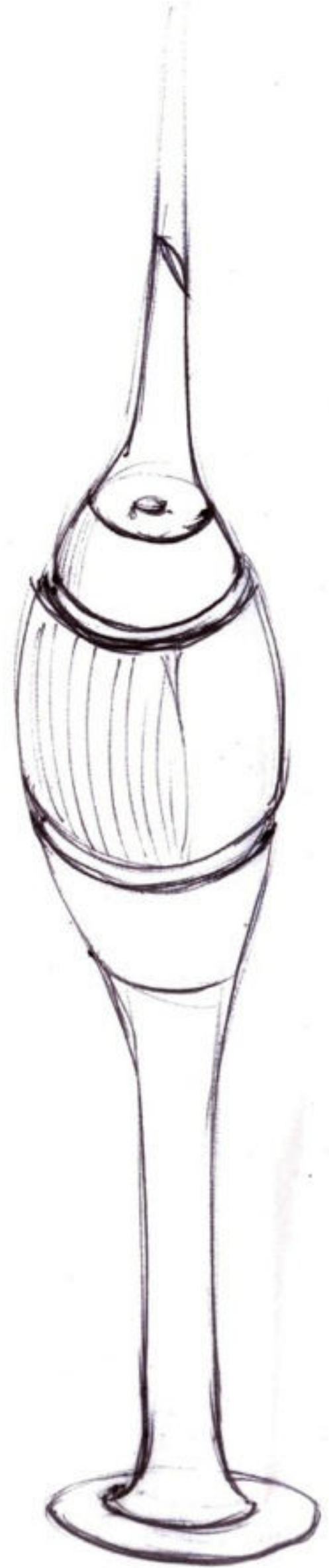
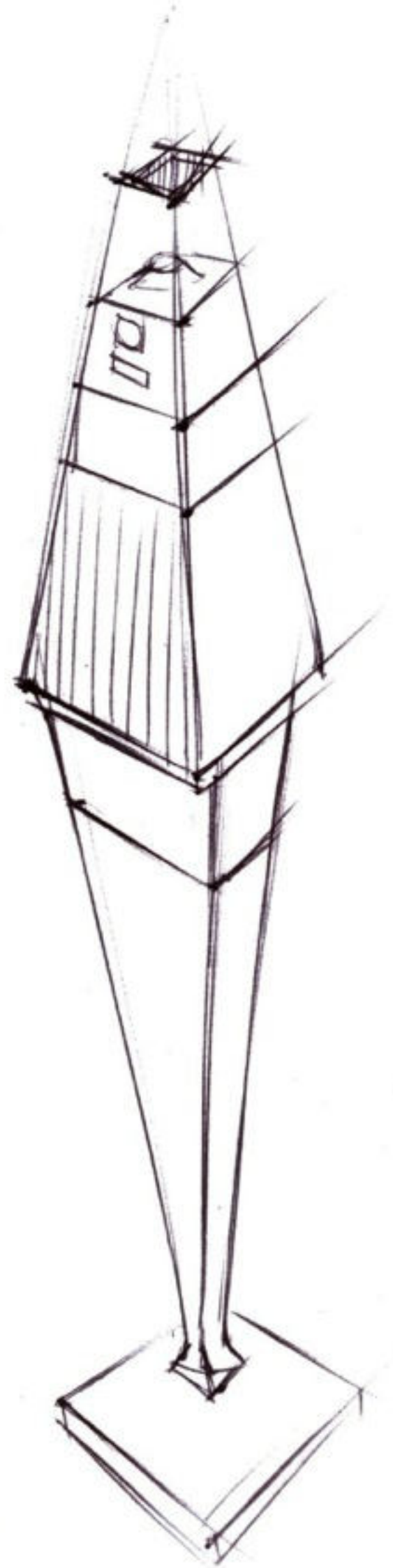
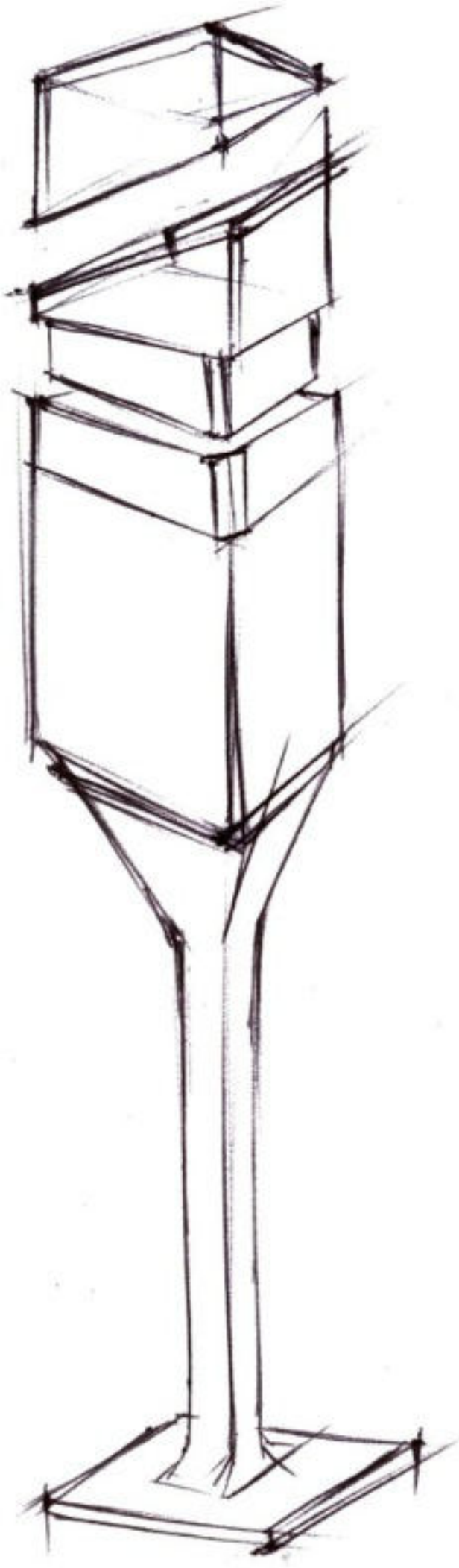

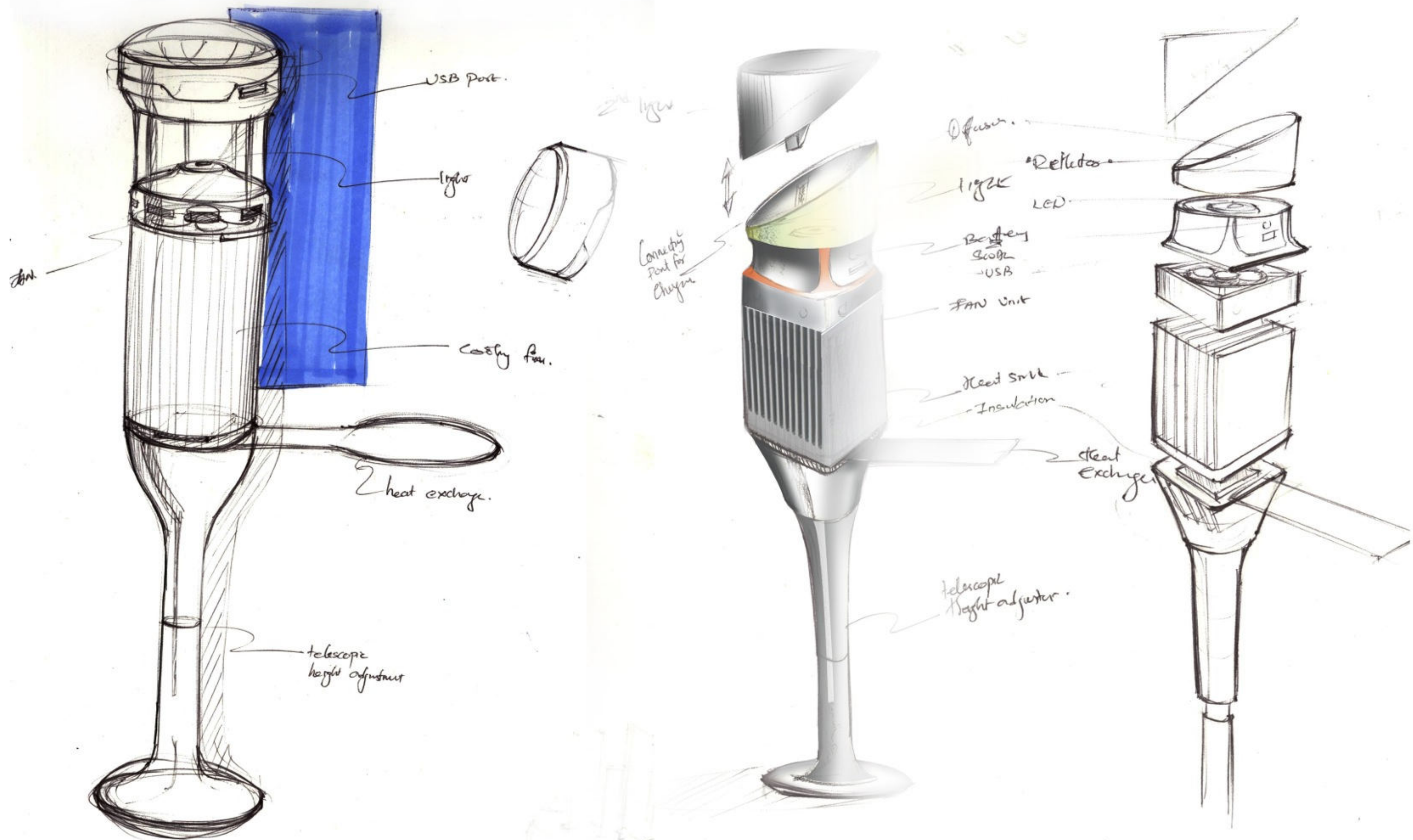

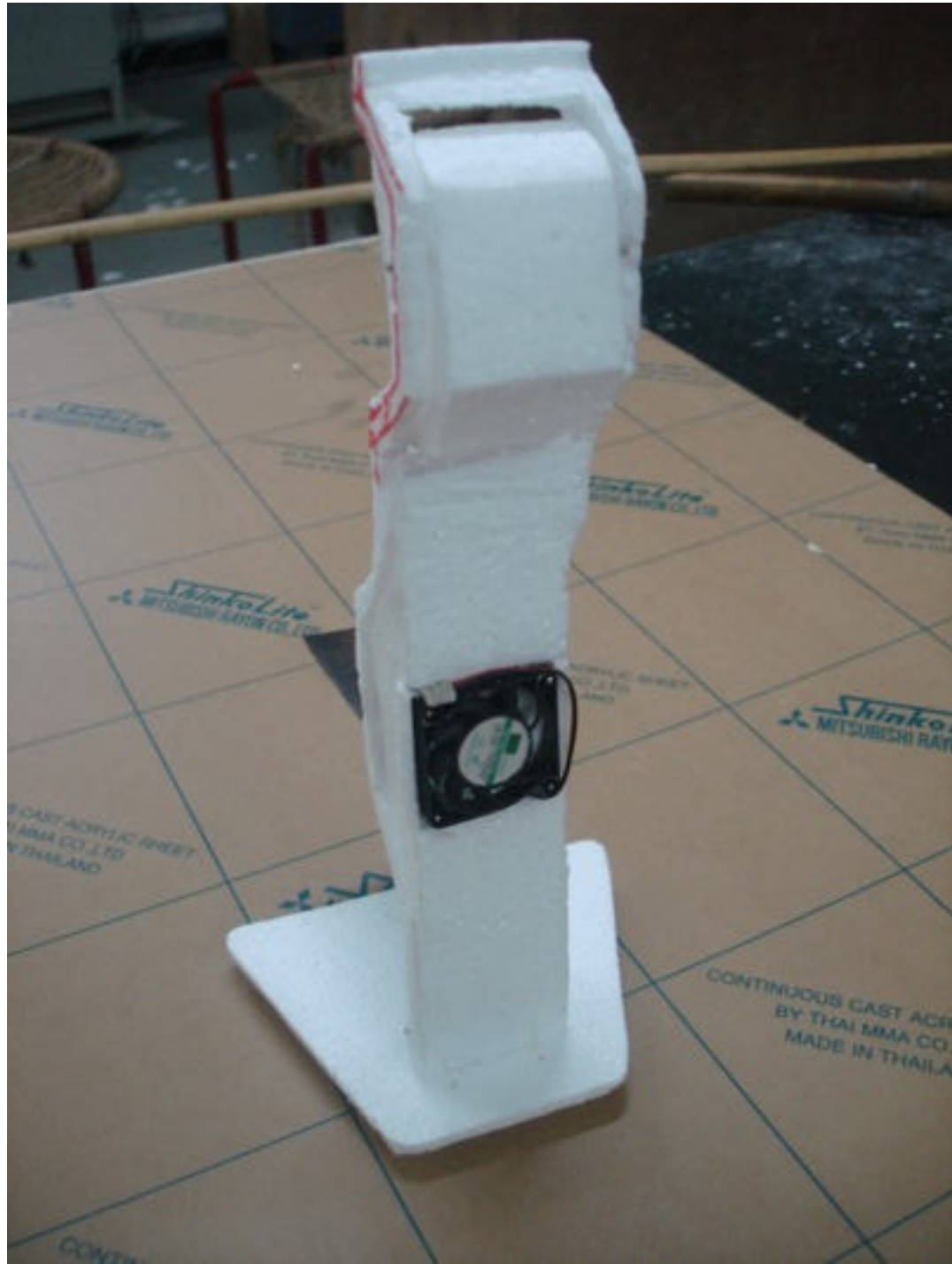

Mock ups



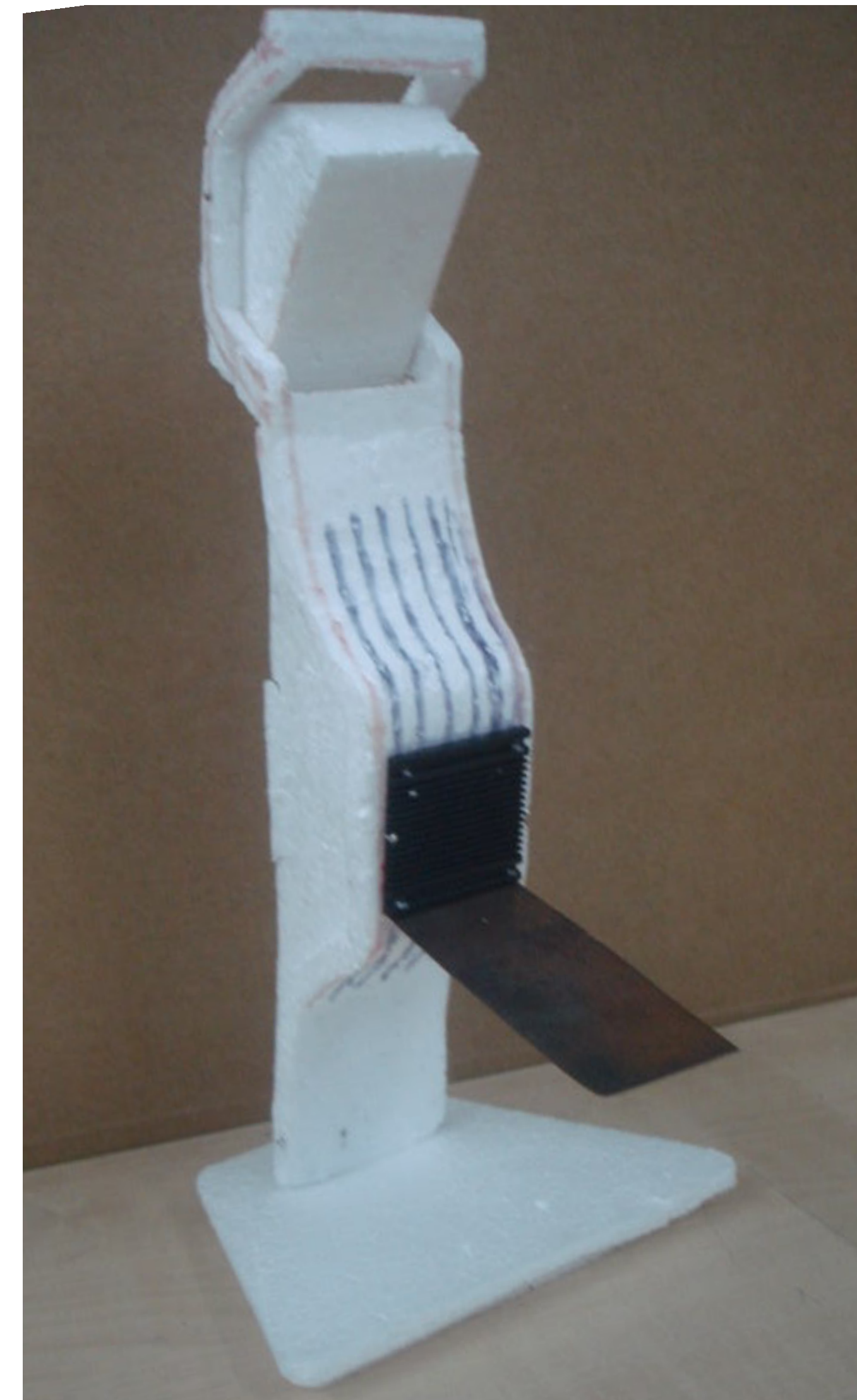
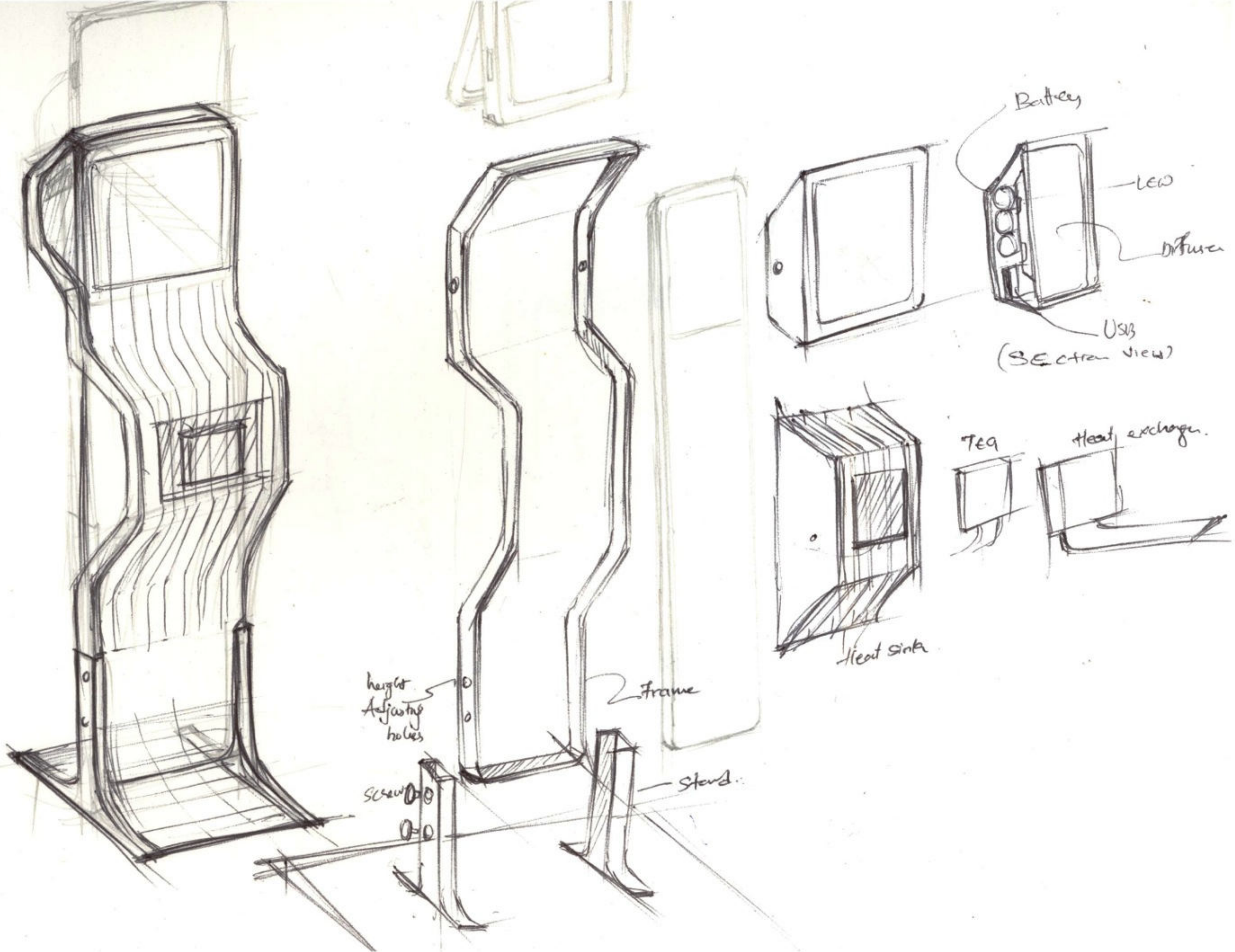

Product description

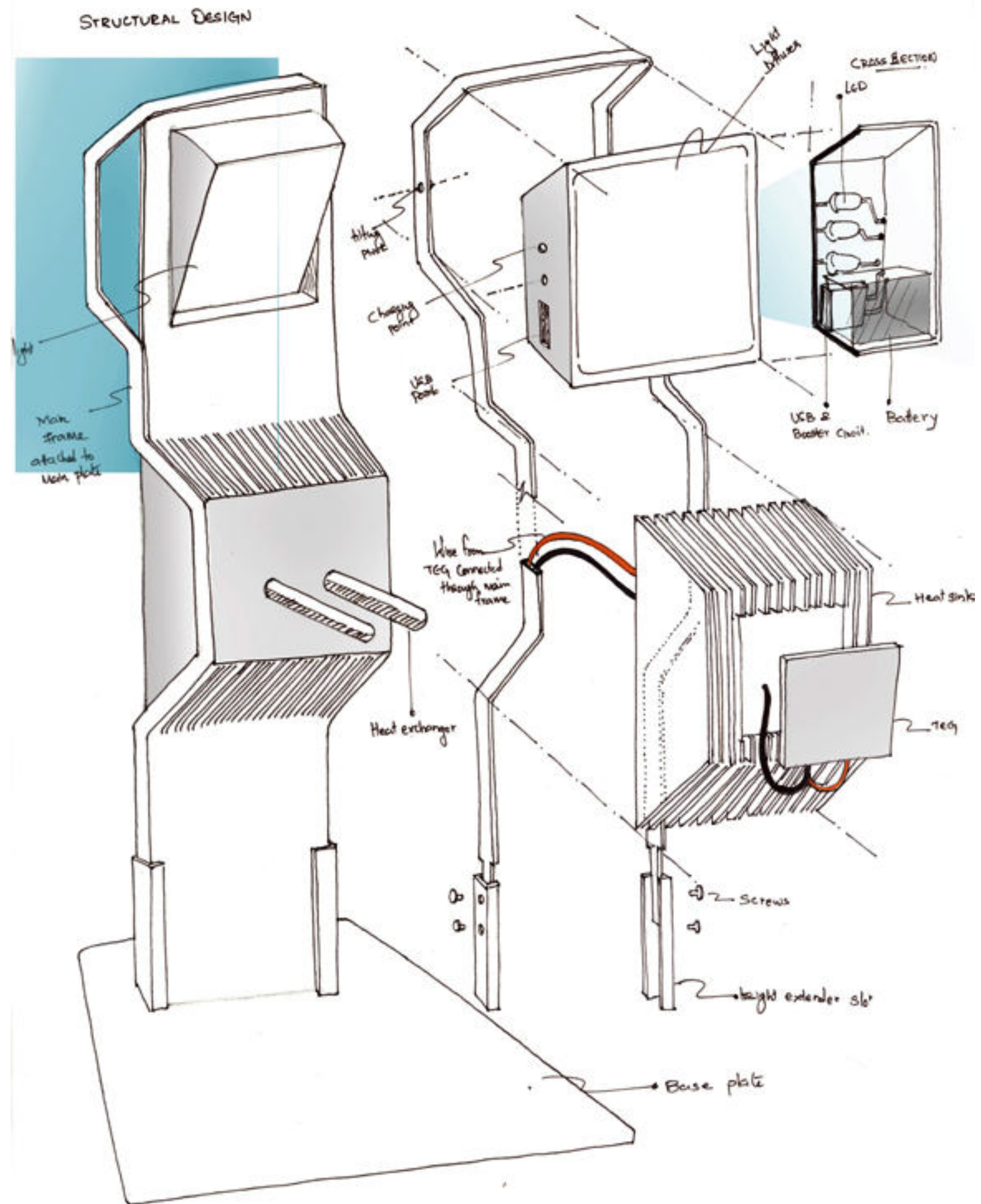

Prototyping

Fabrication



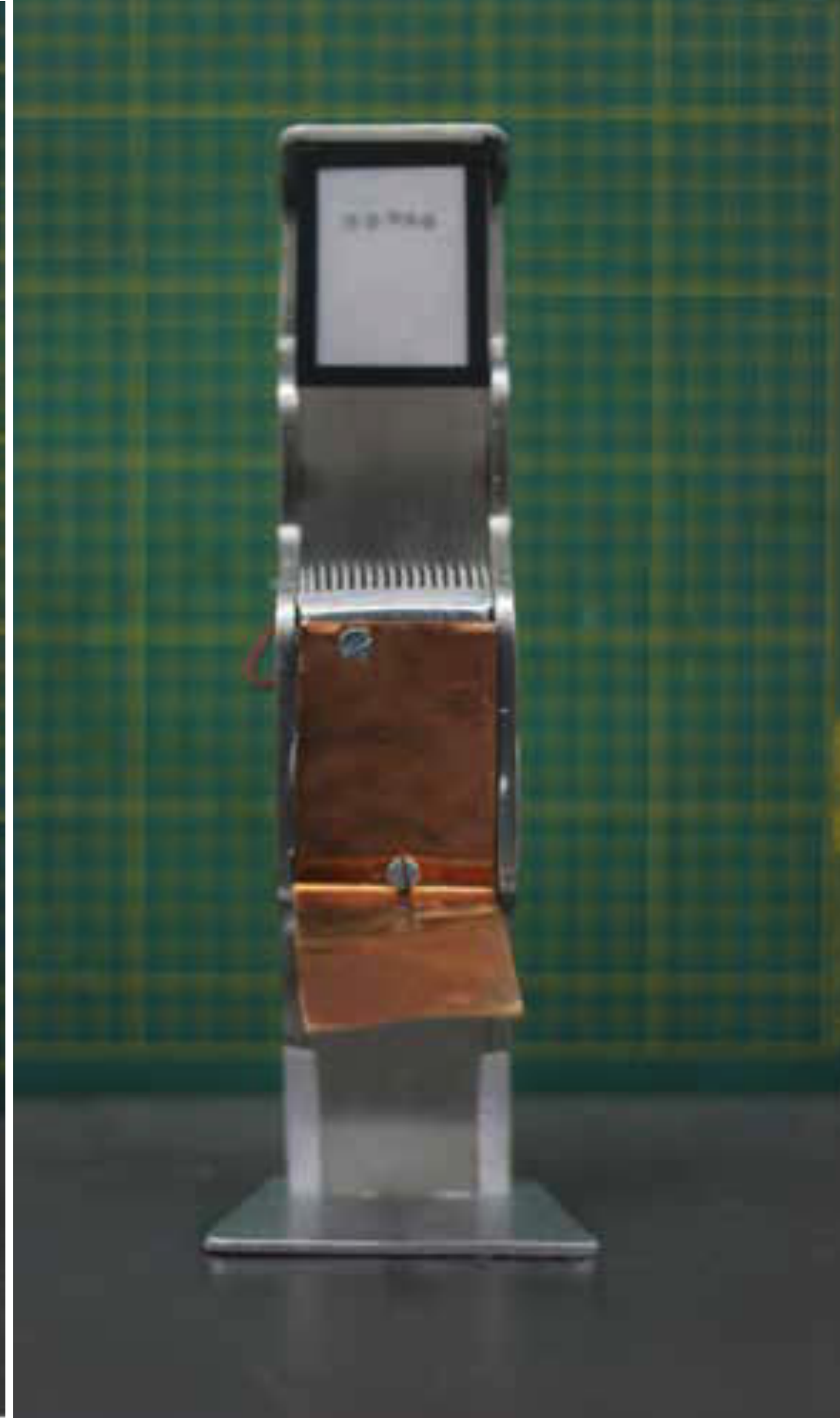

1:2 ratio prototype is made to study the working and the form factor of the product.

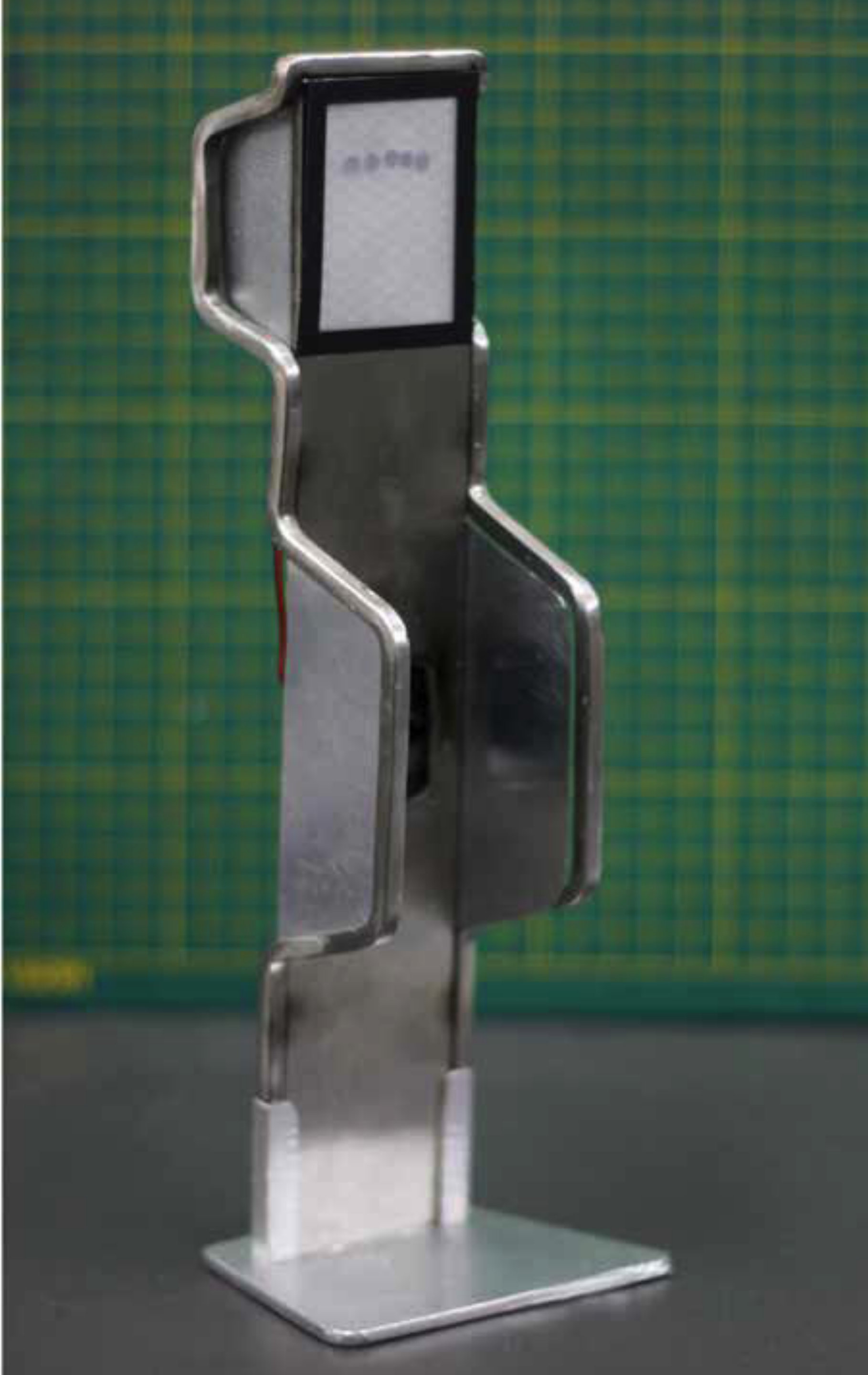

Testing

