



Project III



Customized Vlogging Kit for
YouTube Content Creators

Guided by
Prof. Avinash Shende

Submitted by

Syamlal K S
Industrial Design
206130012



Content

01. Design Methodology	13
02. Introduction	14
03. Secondary Research	15
3.1 Impact of YouTube on digital era	15
3.2 Statistics	17
3.3 Effect of Pandemic	19
3.4 Reasons why people wish to be YouTube Content Creator	20
3.5 Cons of being a YouTube Content Creator	21
3.6 Method of earnings for Content Creators	22
3.7 YouTube Creator awards	23
3.8 Famous you tubers in the world	24
3.9 Famous you tubers in India	25
3.10 Influence of you tubers on the product design industry	26
3.11 Type of YouTube channels and their requirements	
3.11.1 Beauty and fashion Vloggers	27
3.11.2 ASMR videos	28
3.11.3 Comedy/ Pranks/ skit videos	29
3.11.4 Daily vloggers	30
3.11.5 Cooking and recipe videos	31
3.11.6 Art and craft videos	32
3.11.7 Conspiracy videos	33
3.11.8 Gaming videos	34
3.11.9 DIY videos	35
3.11.10 Family vloggers	36
3.11.11 Product review videos	37
3.11.12 Health and fitness videos	38
3.11.13 Educational videos	39
3.11.14 Travel and lifestyle videos	40
3.11.15 Music and dance videos	41
3.11.16 Reaction videos	42
3.11.17 Sports videos	43
3.2 Classification of videos	44
04. User Interviews	45
4.1 User 1	46
4.2 User 2	50
4.3 User 3	56
4.4 User 4	61
4.5 User 5	65
4.6 User 6	69
4.7 User 7	74
4.8 Problem Analysis	78
05. Market Study	79
06. Initial design brief	88
6.1 Area of focus	89



Content

07. Primary research	90
7.1 User journey map	90
7.2 Kitchen types	97
7.3 Self made solutions by users	102
7.4 Kitchen Anthropometry	104
08. Modified Design Brief	105
09. Ideations	106
9.1 Ideation 1	106
9.2 Ideation 1.2	106
9.3 Ideation 2	107
9.4 Ideation 3	107
9.5 Ideation 4	108
9.6 Ideation 5	108
9.7 Ideation 6	109
9.8 Ideation 7	110
9.9 Ideation 8	110
9.10 Ideation 9	111
9.11 Ideation 10	111
9.12 Ideation 11	112
9.13 Ideation 12	112
9.14 Ideation 13	113
9.15 Ideation 14	113
9.16 Ideation 14.1	114
9.17 Ideation 15	114
9.18 Concept Comparison	115
9.19 Concept Evaluation	116
9.20 Concept Development	117
9.21 Concept detailing and additional features	119
10. Mock- up – Hanging pipe Design	121
10.1 Mock up Testing	125
11. Final Concept	127
11.1 Concept 1	128
11.2 Concept 2	129
11.3 Concept 3	130
11.4 Concept 4	131
12. Mock-up – Minimal Aluminum Tube Design	132
12.1 End Capping	132
12.2 Interlocking Mechanism	134
12.3 Mobile Holder Design	135
12.4 Circular cut out detail	136
12.5 Holder mock ups	136
12.6 Aluminium tubes	137
12.7 Magnetic attachment	138
12.8 Different orientations using magnetic attachment	139
12.9 Cooking fumes interference	140



Content

12.10 Mock ups – Fumes testing	140
12.11 Testing proposed solutions- Blower concept	141
12.11.1 Using a USB fan	141
12.11.2 Using a centrifugal laptop fan	141
12.12 Testing proposed solutions - Mirror concept	142
12.13 Eye Movement Analysis	142
12.14 Eye movement experiment	143
12.15 3D Model	145
12.16 Mock up	146
12.17 User Interaction	146
12.18 Charging port	147
13. Dimensional details	148
14. Renderings	149
15. Pre jury Feedback	159
16. Updated Final Design	160
17. Final Mock up	169
18. User Testing	171
19. Packaging	173
20. Issues Resolved	174
21. Final Jury Comments	175
22. Possible Solutions	175
23. Future Scope	176
24. References	177

List of Figures

1.	Figure 1 YouTube founders	14
2.	Figure 2 YouTube logo	14
3.	Figure 3 Infographic 1	15
4.	Figure 4 Infographic 2	15
5.	Figure 5 Infographic 3	16
6.	Figure 6 Infographic 4	16
7.	Figure 7 Infographic 5	16
8.	Figure 8 Infographic 6	16
9.	Figure 9 Country graph	17
10.	Figure 10 Growth graph	17
11.	Figure 11 Platform graph	18
12.	Figure 12 Gender pie chart	18
13.	Figure 13 YouTube icon one	20
14.	Figure 14 YouTube logo	21
15.	Figure 15 YouTube awards	23
16.	Figure 16 customised awards	23
17.	Figure 17 YouTuber 1	24
18.	Figure 18 YouTuber 2	24
19.	Figure 19 YouTuber 3	24
20.	Figure 20 YouTuber 4	25
21.	Figure 21 YouTuber 5	25
22.	Figure 22 YouTuber 6	25
23.	Figure 23 YouTuber 7	26
24.	Figure 24 YouTuber 8	26
25.	Figure 25 beauty bloggers	27
26.	Figure 26 ASMR videos	28
27.	Figure 27 comedy videos	29
28.	Figure 28 Daily bloggers	30
29.	Figure 29 Cooking bloggers	31
30.	Figure 30 Artists	32
31.	Figure 31 Conspiracy videos	33
32.	Figure 32 Gaming videos	34
33.	Figure 33 DIY videos	35
34.	Figure 34 Family bloggers	36
35.	Figure 35 Product logos	37
36.	Figure 36 Fitness bloggers	38
37.	Figure 37 Educational bloggers	39
38.	Figure 38 Travel bloggers	40
39.	Figure 39 Music and dance lovers	41
40.	Figure 40 Reaction videos	42
41.	Figure 41 Sports videos	43
42.	Figure 42 User interviews	45
43.	Figure 43 User 1 profile	46
44.	Figure 44 User 1 equipment	47
45.	Figure 45 User 1 camera angles	48
46.	Figure 46 User 1 problems	49
47.	Figure 47 User 2 profile	50
48.	Figure 48 User 2 camera angles	51
49.	Figure 49 User 2 recording environment	53
50.	Figure 50 User 2 problems	55
51.	Figure 51 User 3 profile	56
52.	Figure 52 User 3 camera angles	57
53.	Figure 53 User 3 equipment	58

List of Figures

54. Figure 54 User 3 equipment	58
55. Figure 55 User 3 equipment 2	59
56. Figure 56 User 3 problems	60
57. Figure 57 User for profile	61
58. Figure 58 User for equipment	62
59. Figure 59 User for camera angles	63
60. Figure 60 User for problems	64
61. Figure 61 User 5 profile	65
62. Figure 62 User fi equipment	66
63. Figure 63 User 5 camera angles	67
64. Figure 64 User 5 problems	68
65. Figure 65 User 6 profile	69
66. Figure 66 User 6 equipment	70
67. Figure 67 User seeks equipment 2	71
68. Figure 68 User 6 camera angles	72
69. Figure 69 User 6 problems	73
70. Figure 70 User 7 profile	74
71. Figure 71 User 7 camera angles	75
72. Figure 72 User 7 camera angles 2	76
73. Figure 73 User 7 problems	77
74. Figure 74 Market study	79
75. Figure 75 Camera and mobile	80
76. Figure 76 Tripod or gimbal	80
77. Figure 77 LED ring lighting mechanisms	80
78. Figure 78 External microphones	80
79. Figure 79 Soft boxes	80
80. Figure 80 Camera remote	80
81. Figure 81 Aluminium tripod	81
82. Figure 82 Gorilla tripod	81
83. Figure 83 Mini tripod	81
84. Figure 84 Long leg tripod	81
85. Figure 85 Flexible tripod	81
86. Figure 86 Ball head	81
87. Figure 87 Pan and tilt	82
88. Figure 88 Gimbal head	82
89. Figure 89 Fluid head	82
90. Figure 90 Motorised tripod	82
91. Figure 91 Tilt head	82
92. Figure 92 Pistol grip	82
93. Figure 93 Panoramic head	83
94. Figure 94 3 way tripod	83
95. Figure 95 Commonly used equipment	83
96. Figure 96 Gorilla tripod	84
97. Figure 97 Tripod with light	85
98. Figure 98 Gooseneck tripod	86
99. Figure 99 Artist view	87
100. Figure 100 Recipe view	89
101. Figure 101 Professional artist table	95
102. Figure 102 Artist problem	96
103. Figure 103 Single walled kitchen	97
104. Figure 104 L shaped kitchen	98
105. Figure 105 U shaped kitchen	99
106. Figure 106 Gallery kitchen	100

List of Figures

107. Figure 107 Island kitchen	101
108. Figure 108 Self made phone attachment	102
109. Figure 109 Phone holder made by own	102
110. Figure 110 Kitchen setup	102
111. Figure 111 Self made camera setup	103
112. Figure 112 Kitchen Anthropometry	104
113. Figure 113 Ideation 1	106
114. Figure 114 Ideation 1.2	106
115. Figure 115 Ideation 2	107
116. Figure 116 Ideation 3	107
117. Figure 117 Ideation 4	108
118. Figure 118 Ideation 5	108
119. Figure 119 Ideation 6	109
120. Figure 120 Ideation 7	110
121. Figure 121 Ideation 8	110
122. Figure 122 Ideation 9	111
123. Figure 123 Ideation 10	111
124. Figure 124 Ideation 11	112
125. Figure 125 Ideation 12	112
126. Figure 126 Ideation 13	113
127. Figure 127 Ideation 14	113
128. Figure 128 ideational 14.1	114
129. Figure 129 radiation 15	114
130. Figure 130 Hanging pipe concept	117
131. Figure 131 Hand on device	117
132. Figure 132 Tightening mechanism	117
133. Figure 133 Usability 1	118
134. Figure 134 Usability 2	118
135. Figure 135 Mechanism	118
136. Figure 136 Usability 3	118
137. Figure 137 Artist using design	119
138. Figure 138 Attachment detail	119
139. Figure 139 Lighting detail	119
140. Figure 140 Mirror function	119
141. Figure 141 Erasable slate	120
142. Figure 142 Fan mechanism	120
143. Figure 143 Holder mechanism	120
144. Figure 144 Gooseneck holder	120
145. Figure 145 Mock up materials	121
146. Figure 146 Mock up detailing	122
147. Figure 147 Magnetic disc mechanism	123
148. Figure 148 Mock up testing	125
149. Figure 149 Mock up insights	126
150. Figure 150 Cable cam	127
151. Figure 151 Cable cam size comparison	127
152. Figure 152 Wire cam ideations	128
153. Figure 153 Mechanism	128
154. Figure 154 Concept 1	128
155. Figure 155 Concept 2	129
156. Figure 156 Concept 2 usability	129
157. Figure 157 Concept 2 steps	129
158. Figure 158 Concept 3	130
159. Figure 159 Concept 3 usability	130



List of Figures

160. Figure 160 Concept 4	131
161. Figure 161 Mock up testing	132
162. Figure 162 End capping details	132
163. Figure 163 Product mock ups	133
164. Figure 164 Interlocking	134
165. Figure 165 Allen key locking	134
166. Figure 166 Mobile holder	135
167. Figure 167 Holder iterations	135
168. Figure 168 Circular cut out	136
169. Figure 169 Mobile holder iterations	136
170. Figure 170 Holder mock ups	136
171. Figure 171 AI tubes	137
172. Figure 172 All tubes dimensions	137
173. Figure 173 Magnetic connection	138
174. Figure 174 Different mobile orientations	139
175. Figure 175 Kitchen fumes	140
176. Figure 176 Fumes mock up	140
177. Figure 177 Blurry video	140
178. Figure 178 USB fan	141
179. Figure 179 Clear video	141
180. Figure 180 Centrifugal fan	141
181. Figure 181 Centrifugal fan 2	141
182. Figure 182 Mirror Concept	142
183. Figure 183 Eye movement analysis	142
184. Figure 184 Eye movement experiment	143
185. Figure 185 Experiment set up	144
186. Figure 186 Possible spots	144
187. Figure 187 3D model	145
188. Figure 188 Mock up testing	146
189. Figure 189 User integration	146
190. Figure 190 Charging detail	147
191. Figure 191 Dimensional details	148
192. Figure 192 Render 1	149
193. Figure 193 Render 2	150
194. Figure 194 Render 3	151
195. Figure 195 Render 4	152
196. Figure 196 Render 5	153
197. Figure 197 Render 6	154
198. Figure 198 Render 7	155
199. Figure 199 Render 8	156
200. Figure 200 Render 9	158
201. Figure 201 Render 10	158
202. Figure 202 Render 11	160
203. Figure 203 Render 12	161
204. Figure 204 Render 13	162
205. Figure 205 Render 14	163
206. Figure 206 Render 15	164
207. Figure 207 Render 16	165
208. Figure 208 Render 17	166
209. Figure 209 Render 18	167
210. Figure 210 Render 18	168
211. Figure 211 Mock up 1	169
212. Figure 212 Mock up 2	170
213. Figure 213 User testing 1	171
214. Figure 214 User testing 2	172
215. Figure 215 Packaging	173

01. Design Methodology

Introduction

Introduction to the scenario and describing the need for the product.

Justifying the choice of topic

Reason for choosing the topic
And defining how the product can benefit the users

Research

Secondary research

Collecting information from the internet regarding the problems caused and how people are affected

Primary research

Collecting information directly from the users to understand the situation and their problems better

Market study

Understand the existing products, their functionality, limitations, material used, manufacturing etc.

Design Brief

Defining the aim of the project

Field visit

Visiting users to understand their working environment and analyze their problems

User Interviews

Preparing questionnaires, analyzing the responses taking photographs, studying their equipment, understanding the users needs better.

Ideation and conceptualizations

Sketching

Initial scribbles
Developing and detailing the ideas

Developing different concepts

Taking different design directions, creating concept ideations and narrowing it down.

Making Mock ups

Making rough mock ups and testing it out with the users to understand workability of the design and add new features if required

Doing further research to find out any possible and viable design to minimize complexities and redefine brief if required.

Rendering, prototyping and testing

Finalizing the concept after concept evaluation and making CAD models.

Final Prototype

Making final prototype to prove the functionality and test it out with the users and make any interventions if any.

Product renderings, animations and recording the data

Testing

Testing the product made with actual users and taking feedback from them to improve the design if necessary in the future

02. Introduction

YouTube

YouTube is a free video-sharing website that simplifies the process of watching online videos. You can also create your own videos and share them with others to watch. With over 6 billion hours of video seen each month, YouTube, which was started in 2005, is now one of the most popular websites on the Internet.

One of the reasons YouTube is so popular is the sheer number of videos available. On average, YouTube receives 100 hours of video per minute, so there's always something new to watch.

YouTuber

A YouTuber is a person who creates videos on the video-sharing network YouTube, specifically on one or more YouTube channels, which are customizable subpages of the platform. In the year 2006, the term was first used in the English language.

Steve Chen, Chad Hurley, and Jawed Karim developed YouTube. The trio were all early workers of PayPal, which benefitted them once eBay purchased the company. Hurley had majored in design at Indiana University of Pennsylvania, and Chen and Karim had majored in computer science at the University of Illinois at Urbana-Champaign.



Steve Chen



Chad Hurley



Jawed Karim

Fig 1 . YouTube Founders

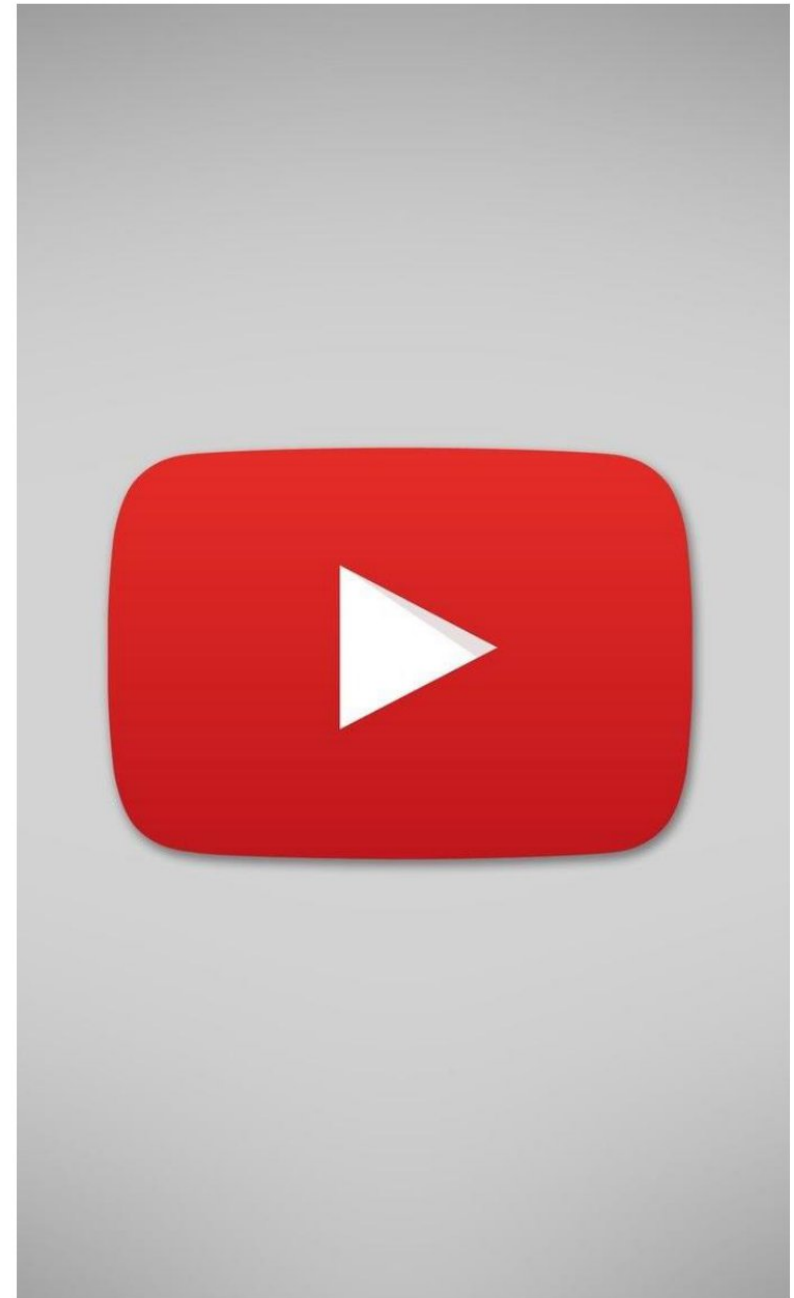

Fig 2 . YouTube logo

03. Secondary Research

3.1 Impact of YouTube on Digital Era

- **Social Media's Second-Most-Popular Platform**

YouTube is the second most popular social media network behind Facebook. YouTube is used by approximately 79 percent of internet users worldwide (Dataeportal, 2019). YouTube has a lot of benefits for users all around the world, whether they're looking for music to listen to, product reviews, movie trailers, covers, or learning. YouTube has expanded consistently and tremendously since Google acquired it from its founding PayPal workers, one of the reasons being its ease of accessibility. The shocks don't seem to stop even today, with the advent of YouTube Red and YouTube music.

- **The Second-Most-Used Search Engine**

It is not only the second most popular social media platform in the globe, but it is also the second most popular search engine behind Google. It has a daily audience of over 1,300,000,000 people and one billion user hours! YouTube, it appears, has answers to all of your questions. It's the most popular way to find "How To" videos all over the world.

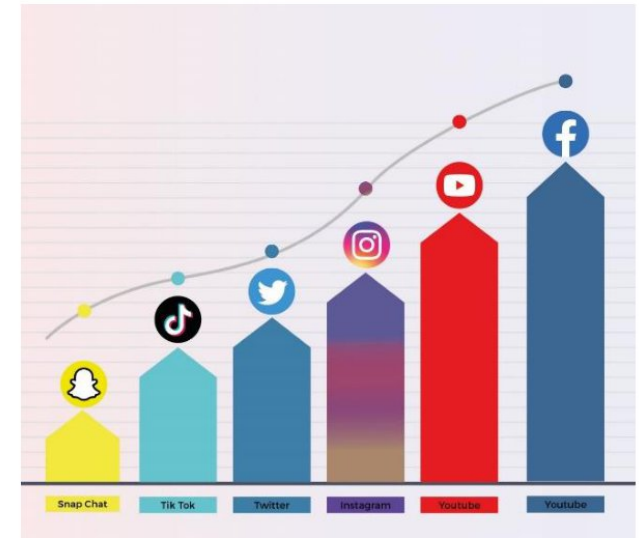

Fig 3 . Infographic 1

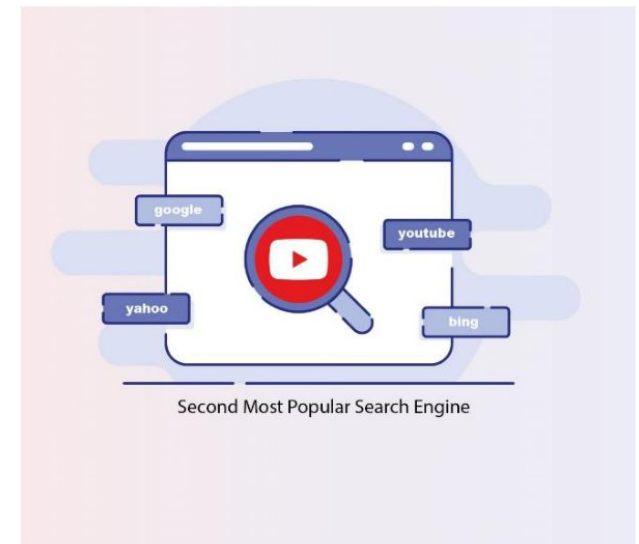

Fig 4 . Infographic 2

- **Business tool**

Because video content is preferred over plain text, a rising number of businesses and brands are using YouTube to market and promote their products and services, either directly through their channels or through YouTube content creators. Because of the platform's global reach, it's a wonderful way to communicate with current customers and attract new ones.

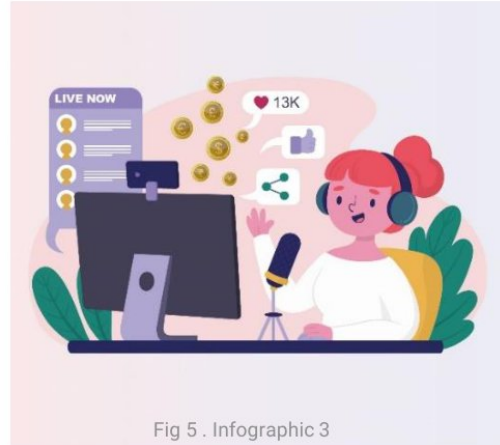

Fig 5 . Infographic 3

- **6) Global Presence**

- One of YouTube's most notable benefits, particularly for corporations, is its global reach. Even if you only speak one language, you can possibly communicate with millions of individuals all around the world. Plus, there's more. Closed captioning increases viewership by making your content more accessible.



Fig 8 infographic 6.

- **Assists Users in Finding New Products**

90 percent of viewers say YouTube introduces them to new items and businesses (Thinkwithgoogle, 2019). While it may not result in a specific purchase, it certainly gets the ball rolling. Because consumers rely on video content more than anything else, YouTube may expose your business to an unparalleled amount of potential customers.

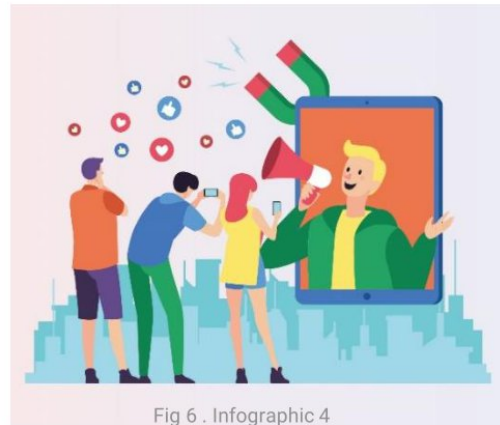

Fig 6 . Infographic 4

- **Upskilling and learning**

YouTube is a popular learning resource for people all around the world. YouTube has the solution to everything, whether it's academics, learning skills like playing musical instruments, cooking, learning how to code, draw, design, or even how to workout. Video tutorials and guides are preferred by users over text since they are easier to understand when seen in action.

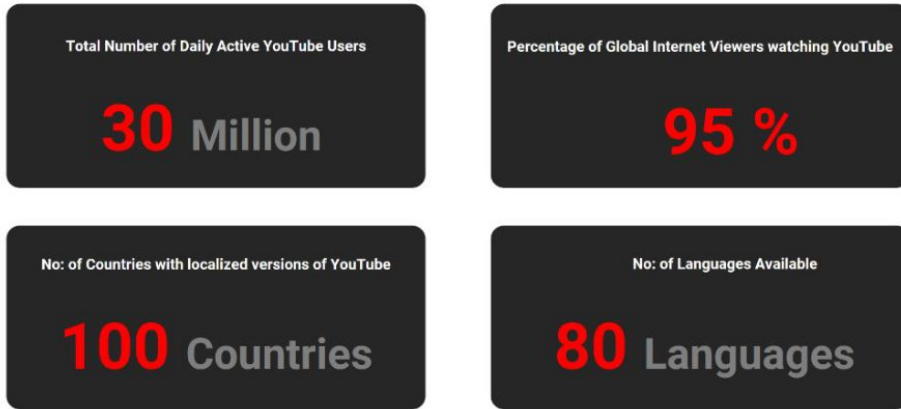

Fig 7 . Infographic 5

3.2 Statistics

YouTube users

The following is a user data of the number of YouTube users across the world



User engagement

The data shows the YouTube user engagement calculated in hours.



YouTube users across the World

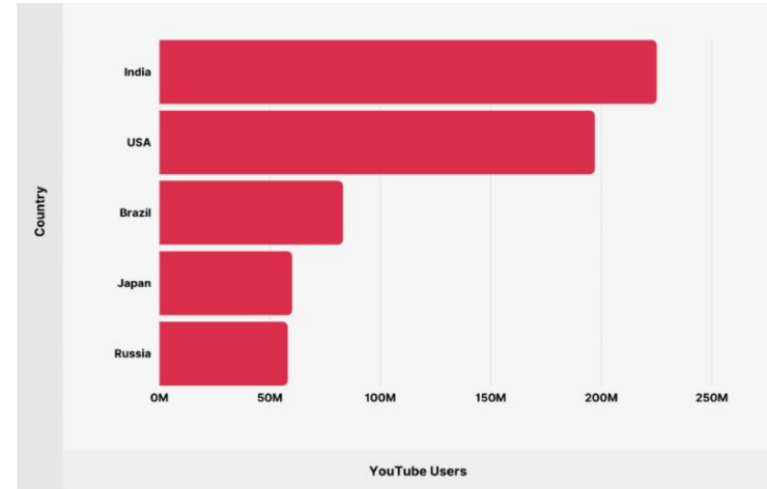

Fig 9 . Country graph

YouTube usage Growth

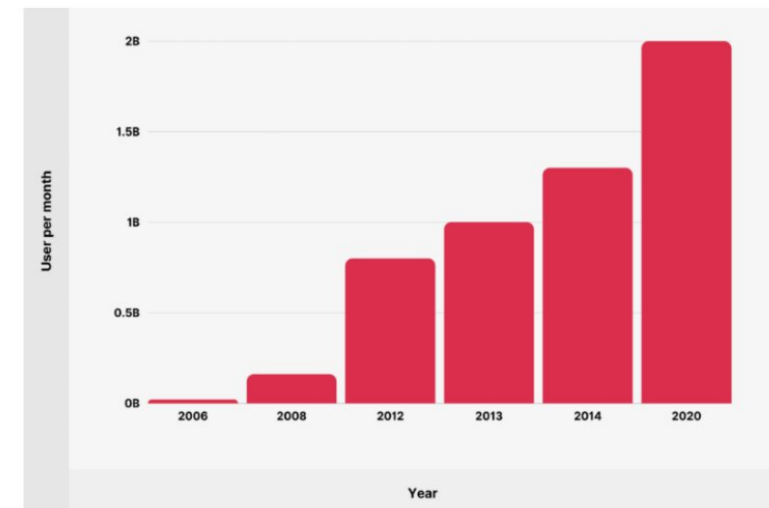

Fig 10. Growth graph

Most used social media platforms

The following graph shows the user count of the famous social media platforms across the world

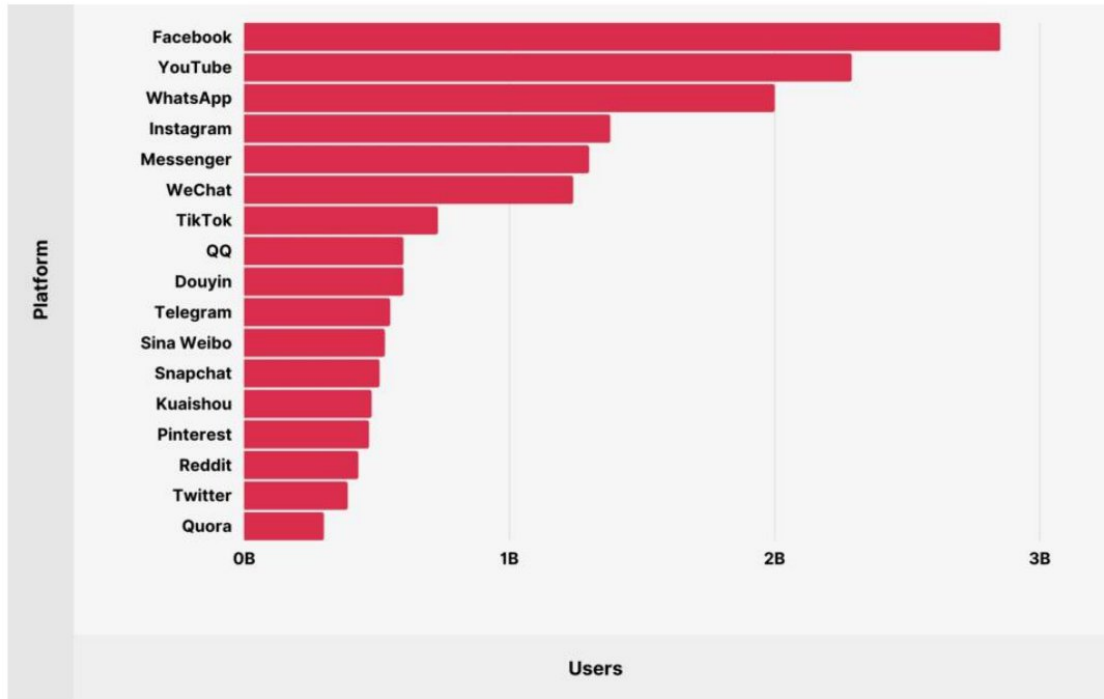

Fig 11 . Platform graph

User Percentage by Gender

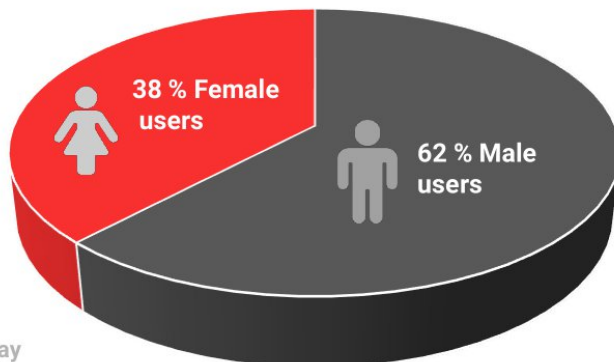
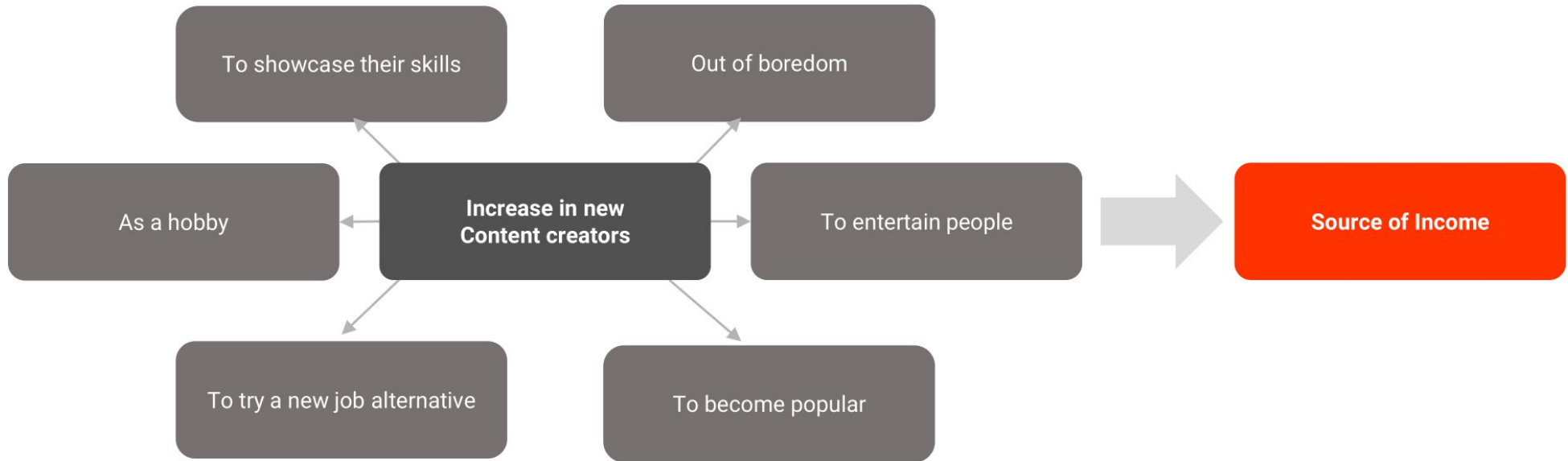

Fig 12. Gender pie chart

3.3 Effect of **Pandemic**

People started spending more time at home - **Social media usage** increased

- Viewers count increased
- Content creators count increased



3.4 Reasons why people wish to be a **YouTube Content Creator**

Popularity

- It provides them a unique identity in the society
- People get a chance to Influence people and gain followers
- They have an opportunity to entertain people
- An opportunity for sharing Knowledge

Source of Income

YouTube can be an extra source of income to the creators. The payment depends upon the following factors –

- Number of subscribers
- Number of watch hours
- Quality of videos
- Brand Promotions

Happiness and Self Satisfaction

- Seeing the viewers enjoying and appreciating the videos gives a feeling of happiness to the creators

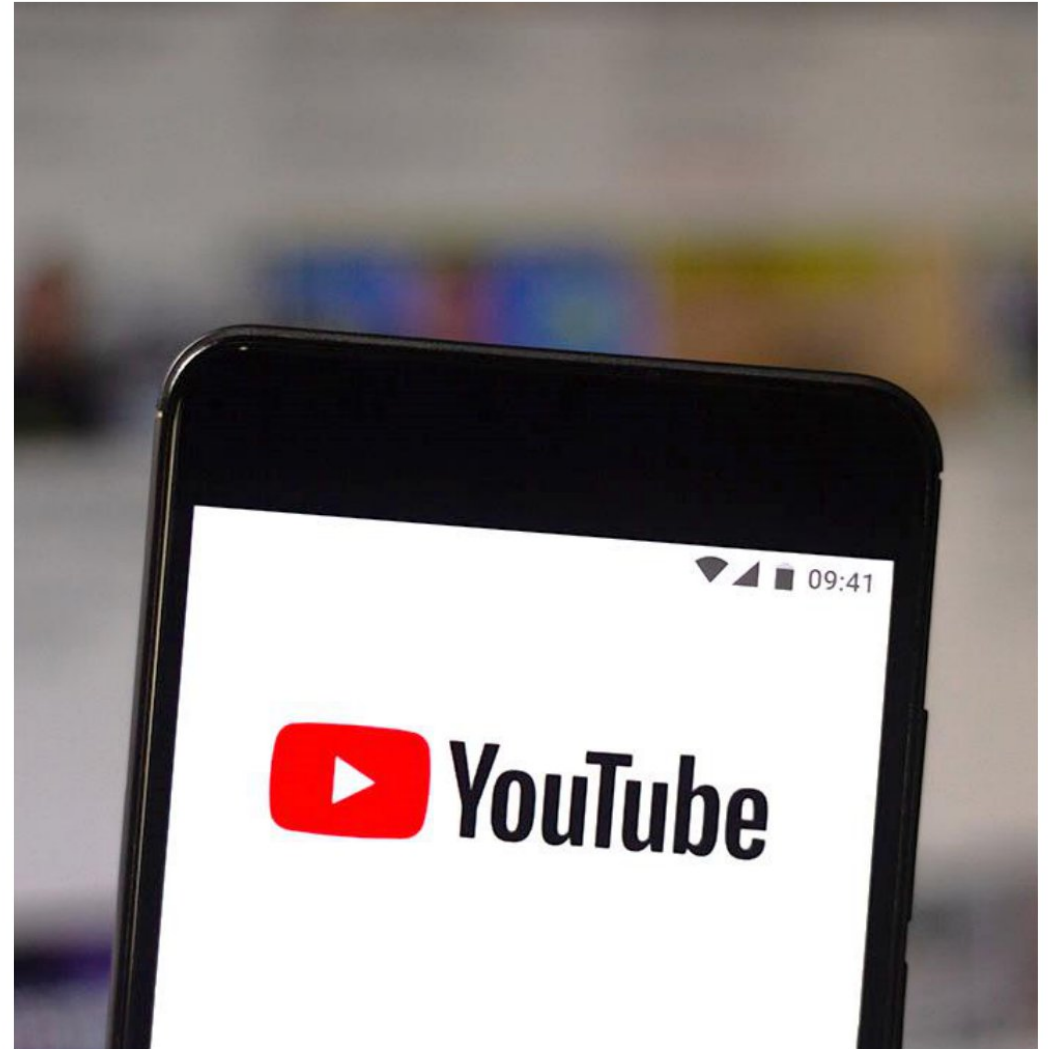

Fig 13 . YouTube icon 1

<https://www.semrush.com/blog/youtut>

3.5 Cons of being a YouTube Content Creator

Privacy issues

- People can lose their freedom while travelling or being in public places as viewers gather around them asking for photos or selfies.

Instability as a career

- Choosing content creation as a career is a risky step.

Burden of creating Contents

- Need to constantly find and generate new contents for revenue generation.

Initial expenses on buying equipment

- The minimal equipment required for creating a good video content may not be affordable for everyone.

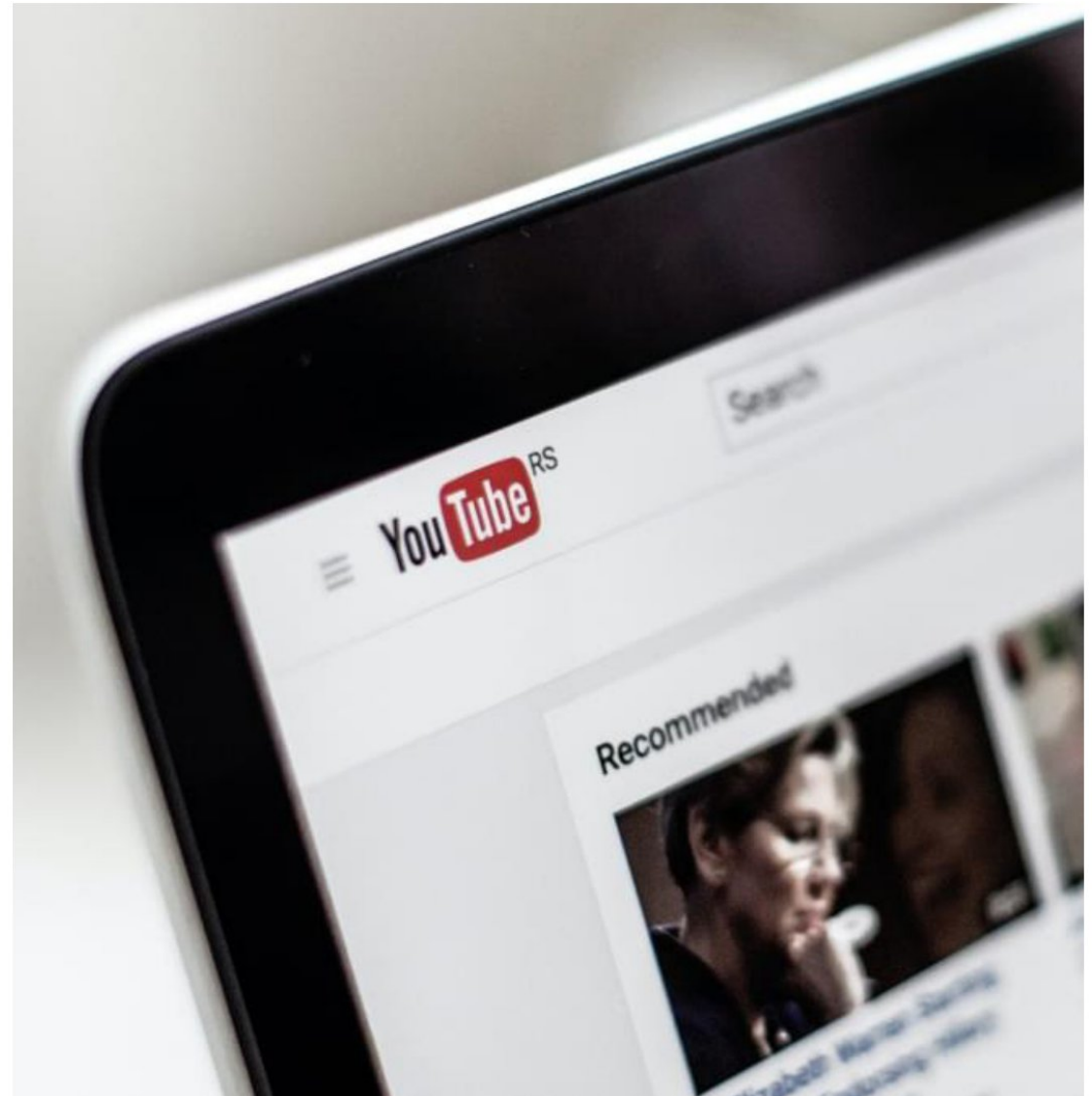

www.globalmediainsight.com/blog/youtube-users-statistics/

Fig 14 . YouTube logo

3.6 Method of earnings for **Content Creators**

Monetization

Content creators can apply for video monetisation once their channel reaches 1000 subscribers and exceeds 4000 watch hours YouTube after verification, starts their payment proceedings according to the reach of their videos.



1000 Subscribers



4000 Watch hours

Apart from monetization, there are few other ways in which the creators and make money from YouTube. They are -



Google ads

Advertisers pay based on clicks and impressions.
YouTube gives the **content creator 55%** of this revenue and **takes 45% for itself.**



Brand Sponsorship

A company will pay a content creator to **promote a brand or product** within a video



Fan funding

Fans and followers make recurring **monthly payments** in exchange for bonus content such as **badges, emojis, special videos, live chats, and other content**



Merchandise Sales

YouTube partners also have the ability **to sell up to 12 items** of merchandise to their audience by enabling this feature in their accounts.

3.7 YouTube Creator Awards

To encourage the creators to contribute more content, YouTube gives creator awards to the creators according to their subscriber count. They are usually made in the form of Play Buttons. They give -

- **Silver Play button** - for **1 Lakh Subscribers**
- **Golden Play Button** – for **1 Million Subscribers**
- **Diamond Play Button** – for **10 Million Subscribers**



Fig 15 . YouTube awards



Fig 16 . Customize awards

In addition to this , they give customized Play Buttons for very famous content creators who manage to touch the mark of 50 Million subscribers. They may even customize it according to the users logo to make it more special and valuable. The creators get a sense of achievement form these.

3.8 Famous YouTubers in the World

Following are some of the most successful You tubers in the world form different content areas and who have managed to gather a lot of subscribers all over the world and are earning in millions.



Fig 17 . YouTuber 1

Felix Arvid Ulf Kjellberg

Channel Name – PweDiePie

Subscriber count - 111 Million

Content - Gaming Videos

Net worth - \$ 54 M = ₹ 400 cr +



Fig 2 . YouTube logo

Fig 18 . YouTuber 2

Jimmy Donaldson

Channel Name – MrBeast

Subscriber count - 88.9 Million

Content - Comedy Videos

Net worth - \$ 54 M = ₹ 400 cr +



Fig 19 . YouTuber 3

Anastasia Radzinskaya

Channel Name - Like Nastya

Subscriber count – 86.1 Million

Content - Day to day activities

Net worth - \$20 M = ₹ 150 cr +

3.9 Famous YouTubers in India

Following are some of the most successful You tubers in India form different content areas and who have managed to gather a lot of subscribers.



Fig 20 . YouTuber 4

Ajey Nagar

Channel Name - Carryminati

Subscriber count - 34.4 Million

Content – Comedy and Roasting videos

Net worth - ₹ 30 cr 65 lkhs



Fig 21 . YouTuber 5

Nisha Madhulika

Channel Name - Nisha Madhulika

Subscriber count – 12.3 Million

Content – Cooking and Recipe

Net worth - ₹ 20 cr 65 lkhs



Fig 22 . YouTuber 6

Harun Robert

Channel Name - Mad Stuff with Rob

Subscriber count – 2.43 Million

Content – Art and Craft

Net worth - ₹ 7 cr 51 lkhs

3.10 Influence of YouTubers on the **Product Design Industry**

YouTube has become a major source of tech information for a user who is planning to buy a new gadget. There are a lot of channels which help them with their reviews as well and help the users to choose the correct product according to their requirements.

Some tech review channels like Unbox Therapy and Marques Brownlee have become so influential that their good reviews can shoot up a companies production to a great extent. So the companies, before launching a new product in the market, send it to such tech reviewers and pay them for reviewing their products. In this way the content creators and the companies get a mutual benefit form each other for their growth.



Fig 23 . YouTuber 7

Unbox Therapy



Fig 24 . YouTuber 8

Marques Brownlee

3.11 Types of YouTube Channels and their Requirements

3.11.1 Beauty and Fashion Vloggers

Beauty and Fashion YouTubers are well known for their expertise on the subjects of makeup and skincare. As trendsetters within the beauty industry, they often set a precedent for what brands and products will be most popular.

YouTubers that fit within the fashion category specialize in clothing and accessories. The most successful come to the platform with a strong sense of style and an eye for upcoming trends.

Recording space – Indoor

Camera angles – 1 or 2

Requirements

- **Video Recording Device** – Mobile or camera
- **Audio Recording Device** – Microphone
- **Device holder** - Tripod
- **Lighting** – Ring light [preferred]
- **Other materials required** – Beauty and make up kits , Outfits

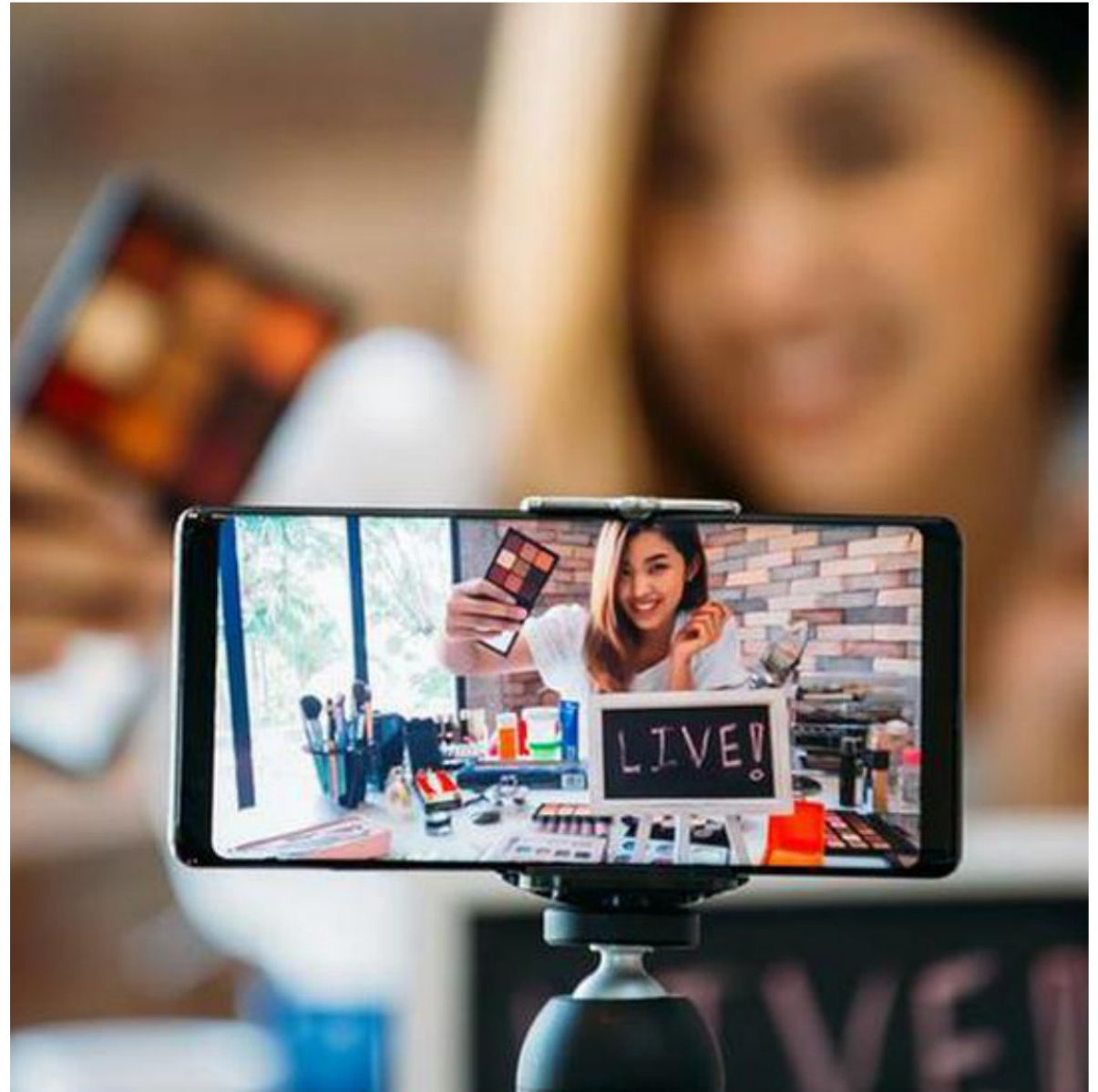

Fig 25 . Beauty Vloggers

3.11.2. ASMR Videos

[Autonomous Sensory Meridian Response]

ASMR refers to the soothing sensation felt when someone brushes their fingertips lightly over your skin or whispers softly in your ear. YouTubers with ASMR channels cover various topics and can even combine their topics with other niches like make-up and how-to. The main attraction, however, is the soothing sounds & imagery used by these YouTubers to relax their viewers.

Recording space – Mainly indoor

Camera angles – 1 or 2

Requirements

- **Video Recording Device** - High resolution video camera (Often capable of slow motion recording)
- **Audio Recording Device** – HD microphone
- **Device holder** - Tripod
- **Lighting** – Studio lighting
- **Other materials required** – Random everyday objects

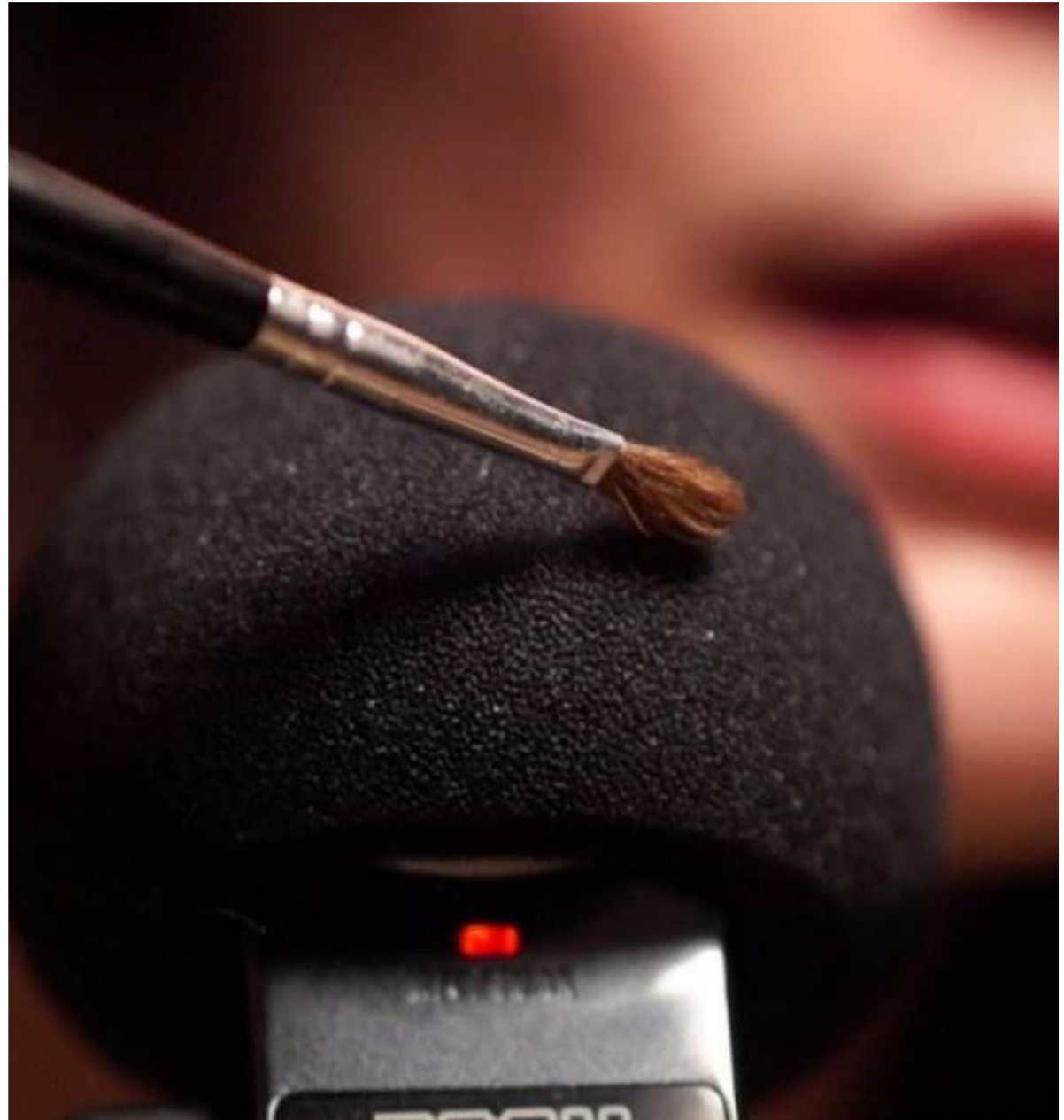

Fig 26 . ASMR videos

3.11.3 Comedy / Pranks / Skit Videos]

YouTubers specializing in comedy are known for poking fun at everyday human problems, creating original skits and characters, and publishing content intended to make people laugh.

Recording space – Indoor and Outdoor

Camera angles – Multiple

Requirements

- **Video Recording Device** – Camera and Mobile
- **Audio Recording Device** – Collar mics
- **Device holder** -
Tripod - No : depends on the type of videos
Gimbal
Drones
- **Lighting** – Natural or Studio lighting



Fig 27 . Comedy Vlogger

3.11.4 Daily Vloggers

Daily vloggers are some of the most consistent creators on YouTube, publishing a video every day..

Recording space – Indoor and Outdoor

Camera angles – 1

Requirements

- **Video Recording Device** – Mobile
- **Audio Recording Device** – Mobile , Headset
- **Device holder** - Handheld / Gimbal / Selfie stick
- **Lighting** – Natural light



Fig 28 . Daily vloggers

3.11.5 Cooking and Recipe Videos

For cooking connoisseurs and those just learning to cook, cooking YouTubers are an excellent source for new recipes. This type of YouTuber teaches viewers how to prepare meals through guided tutorials.

Recording space – Indoor

Camera angles – 2

Requirements

- **Video Recording Device** – Camera / Mobile
- **Audio Recording Device** – Collar mic / Headset
- **Device holder** - Tripod
- **Lighting** – Studio lighting



Fig 29 . Cooking vloggers

3.11.6 Art and Craft Videos

Design/art YouTubers are those who create videos showcasing their art expertise and help others to improve their artistic skills. Creators within the group explore many different mediums, including traditional drawing, digital drawing, graphic design, and painting.

Recording space – Indoor

Camera angles – 2

Requirements

- **Video Recording Device** – Camera / Mobile
- **Audio Recording Device** – Mobile / Microphone / Headset
- **Device holder** - Tripod
- **Lighting** – Natural or Ring light



Fig 30 . Artists

3.11.7 Conspiracy Videos

Makes videos regarding mysterious things by studying interesting and attention grabbing facts which and keeps the viewers engaged and makes him think and draw conclusions on his own.

Recording space – Indoor

Camera angles – 1

Requirements

- **Video Recording Device** – Camera / Mobile
- **Audio Recording Device** – Mobile / Microphone / Headset
- **Device holder** - Tripod
- **Lighting** – Natural or Ring light



Fig 31 . Conspiracy vloggers

3.11.8 Gaming Videos

YouTube has become a popular gathering place for video game enthusiasts, leading to the rise of the gaming YouTuber type. As their title suggests, gaming YouTubers are those that create content focused on video games. They help viewers improve their skills and provide entertainment to a gaming-focused audience.

Recording space – Indoor

Camera angles – 1 or 2

Requirements

- **Video Recording Device** – Camera / Mobile + Laptop screen recording
- **Audio Recording Device** – Microphone / Headset
- **Device holder** - Tripod or none
- **Lighting** – Natural or Mood light



Fig 32 . Gaming vloggers

3.11.9 DIY Videos

Known for their creativity and frugality, DIY YouTubers teach viewers how to make customized items instead of buying them ready-made. A DIY video might teach audiences how to embellish their jeans, decorate their phone case, or revamp their bedroom.

Recording space – Indoor and Outdoor

Camera angles – 2

Requirements

- **Video Recording Device** – Camera / Mobile
- **Audio Recording Device** – Mobile / Microphone / Headset
- **Device holder** - Tripod
- **Lighting** – Natural or Studio light



Fig 33 . DIY vloggers

3.11.10 Family Vloggers

Family YouTubers are best known for sharing the joys and challenges associated with raising a family. Parents typically run family channels and post videos in the form of vlogs, which depict daily moments from a first-person perspective.

Recording space – Indoor and Outdoor

Camera angles – Multiple

Requirements

- **Video Recording Device – Mobile**
- **Audio Recording Device – Mobile**
- **Device holder – Handheld / Tripod**
- **Lighting – Natural**



Fig 34 . Family vloggers

3.11.11 Product Review Videos

Technology may be the niche that comes to mind when you're thinking about reviews & unboxing channels. The interest in review & unboxing channels for viewers is to gauge whether a specific product will be worthwhile purchasing.

These are most popular with tech channels, smartphones, computers & cameras being some of the most popular products reviewed.

Recording space – Indoor

Camera angles – 3

Requirements

- **Video Recording Device** – Camera / Mobile
- **Audio Recording Device** – Mobile / Microphone / Headset
- **Device holder** - Tripod/ Selfie stick / handheld / Gimbal
- **Lighting** – Natural light , Studio light , Ring lighting



Fig 35 . Product vloggers

3.11.12 Health and Fitness Videos

Health and fitness YouTubers detail their workout routines and diets for audiences in an effort to inspire others to lead a healthier lifestyle. Some post full-length workout videos that viewers can take with them to the gym or complete in the comfort in their own home. Others post short clips that guide viewers through quick workouts or new exercises.

Recording space – Indoor (House or Gym)

Camera angles – 1 or 2

Requirements

- **Video Recording Device** – Camera / Mobile
- **Audio Recording Device** – Mobile / Collar mics / Headset
- **Device holder** - Tripod
- **Lighting** – Natural lighting , Ambient lighting



Fig 36 . Fitness vloggers

3.11.13 Educational Videos

Learning YouTubers epitomize the democratization of knowledge made possible by the internet. Creators of this type educate viewers of all ages on a wide range of topics, including science, reading, foreign languages, and more.

Recording space – Indoor

Camera angles – 1 or 2

Requirements

- **Video Recording Device** – Camera / Mobile
- **Audio Recording Device** – Mobile / Collar mics / Headset
- **Device holder** - Tripod
- **Lighting** – Natural , Ring light. Studio light



Fig 37 . Educational vloggers

3.11.14 Travel and Lifestyle Videos

As YouTube has grown the platform has become a hub for first-hand travel and adventure knowledge. Previously, individuals relied primarily on websites and books to plan vacations. Today, travel YouTubers bring viewers on their adventures and lend helpful travel recommendations along the way.

Recording space – Outdoor

Camera angles – 1

Requirements

- **Video Recording Device** – Camera / Mobile / Gopro
- **Audio Recording Device** – Mobile / Microphone / Headset
- **Device holder** - Mini Tripod / Gimbal / Selfie stick / Drones
- **Lighting** – Natural lighting



Fig 38 . Travel vloggers

3.11.15 Music and Dance Videos

Music channels can take many forms on YouTube. Singers, songwriters, choreographers & dancers are all apart of this category. Singers and songwriters produce their own original compositions or cover popular pieces.

Recording space – Indoor

Camera angles – 1 or 2

Requirements

- **Video Recording Device** – Camera / Mobile
- **Audio Recording Device** – Mobile , Microphone
- **Device holder** - Tripod
- **Lighting** – Natural / Studio light / Ambient light



Fig 39 . Music and dance vloggers

3.11.16 Reaction Videos

Makes videos by giving real time reactions on the videos suggested by the viewers and expresses their opinions about the videos while watching it.

Recording space – Indoor

Camera angles – 1

Requirements

- **Video Recording Device** – Camera / Mobile
- **Video seeing device** – Laptop
- **Audio Recording Device** – Headset / Mobile
- **Device holder** - Mini Tripod
- **Lighting** – Natural / Studio light / Ambient light



Fig 40. Reaction videos

3.11.17 Sports Videos

Sports channels generally require one thing, a sporting talent. People showcase their sporting talents and records the videos to entertain the viewers. It can be funny or skillful as far as the viewer finds it interesting.

Recording space – Outdoor

Camera angles – Multiple

Requirements

- **Video Recording Device** – Camera / Mobile
- **Audio Recording Device** – Headset / Mobile / Microphone
- **Device holder** - Tripod / Gimbal
- **Lighting** – Natural lighting



Fig 41 . Sports vloggers

3.12 Classification of Videos

The types of Content creators were classified according to their recording environment and the lighting conditions required. The white dot represents cases where external lighting is required

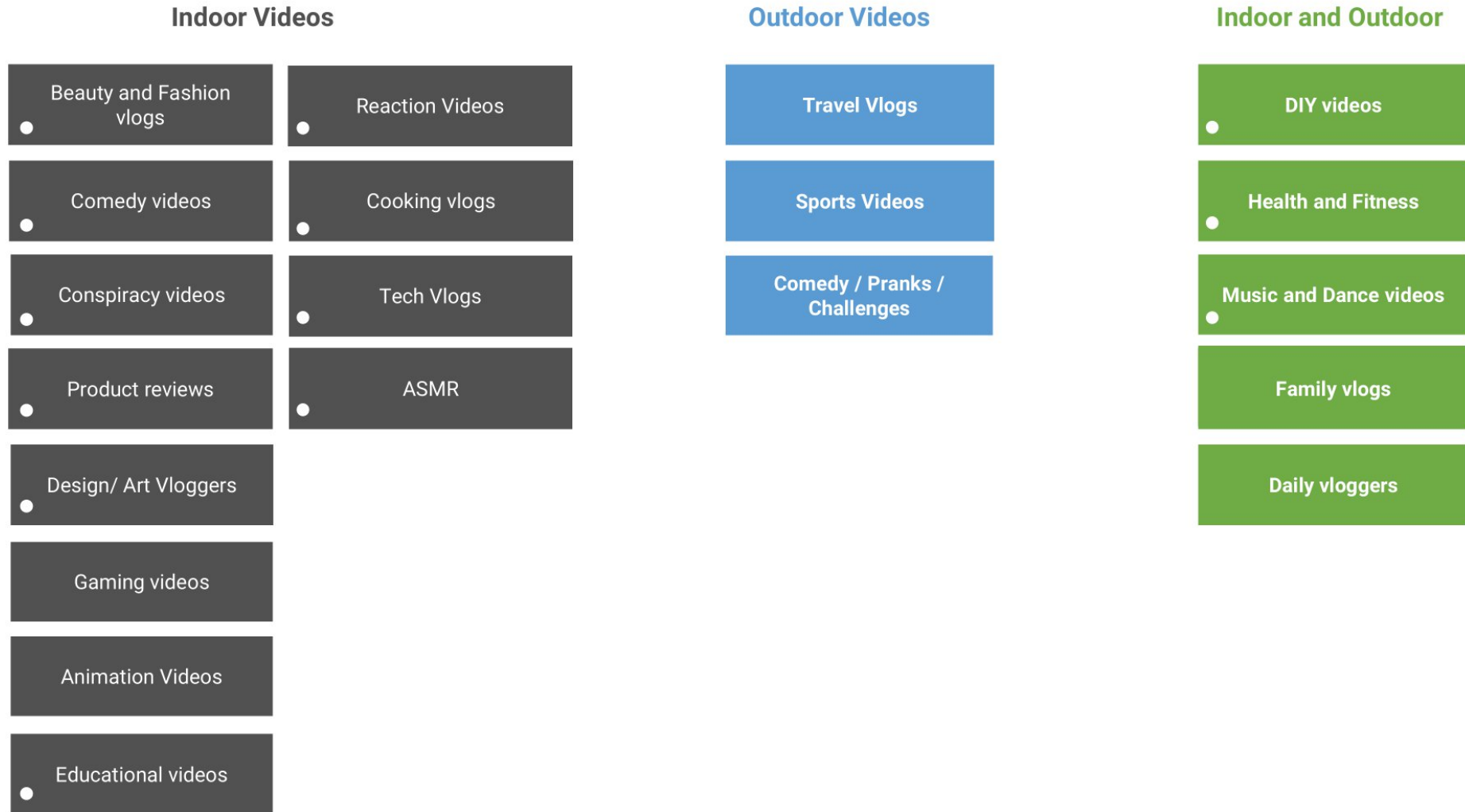

04. User Interviews

Different content creators from various different categories were interviewed and the difficulties they faced were carefully recorded and analysed.



Fig 41. User interviews

4.1 User 1

Art and Craft Vlogger



Name : Deepti Verma

Channel name : Crafturlove

Location : Rajasthan

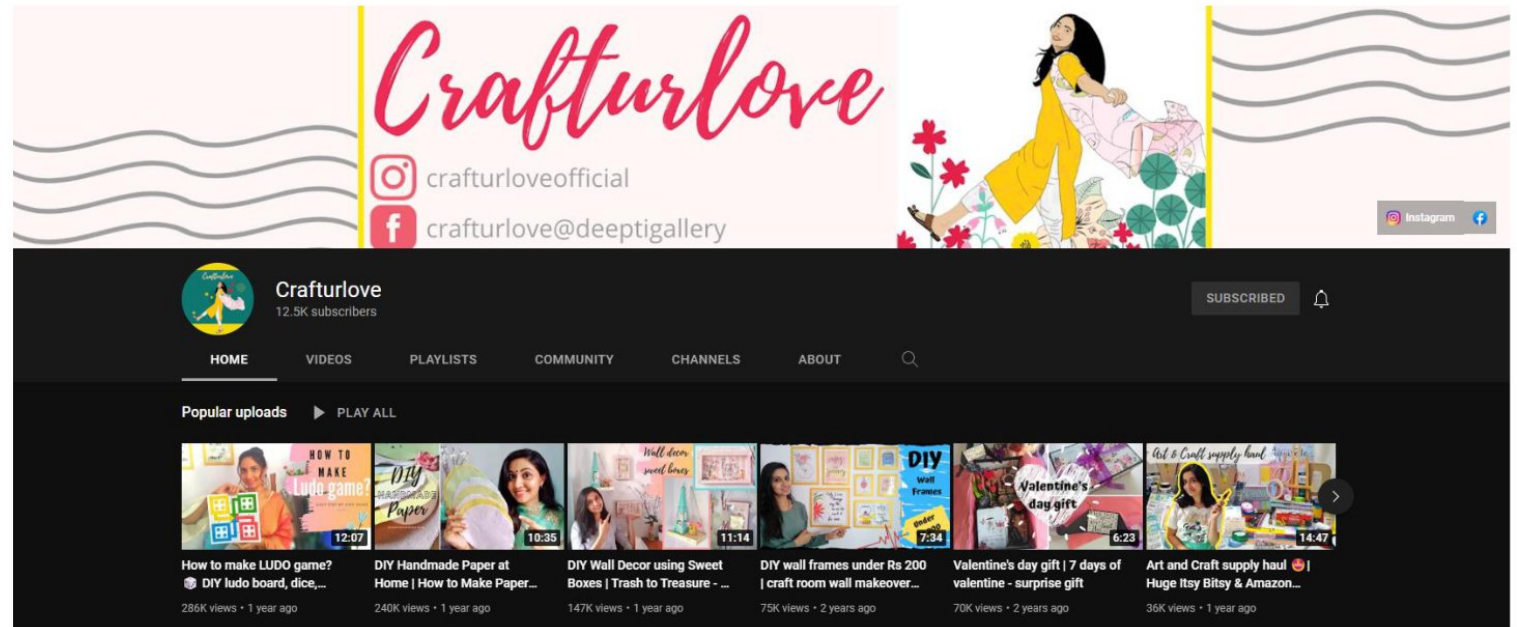

Fig 42 . User 1 profile



Recording Space
Indoor



Camera Angles
2



Lighting
Natural light

Recording Device
Mobile - Samsung F62



Equipment used



Tripod



Gorilla tripod



Bluetooth controller

Storage
In the shelf



Different content creators from various different categories were interviewed and the difficulties they faced were carefully recorded and analysed.



Camera angles used



1. Vertically set camera angle – At a sitting height slightly above eye level



2. View form top (Works sitting on the floor)– Using Tripod



Backdrop – None



Time taken for whole Setup – 15 mins



Mobile camera used – Front cam for introduction , Back cam for shooting craftworks



Additional helpers – No one

Working Environment



Natural Lighting

Tripod – Leaning forward position.

Floor – Used as the working platform

Problems Encountered



Dumbbell plate used on one of the legs for stability



Balancing the tripod in Top view recording



Dependability on Natural lighting – Records in daylight only



Storage – No dedicated space for storage and protection



Portability – Shifting the equipment for scene change and carrying it around



Misplacing the Bluetooth controller

4.2 User 2

Craft Vlogger

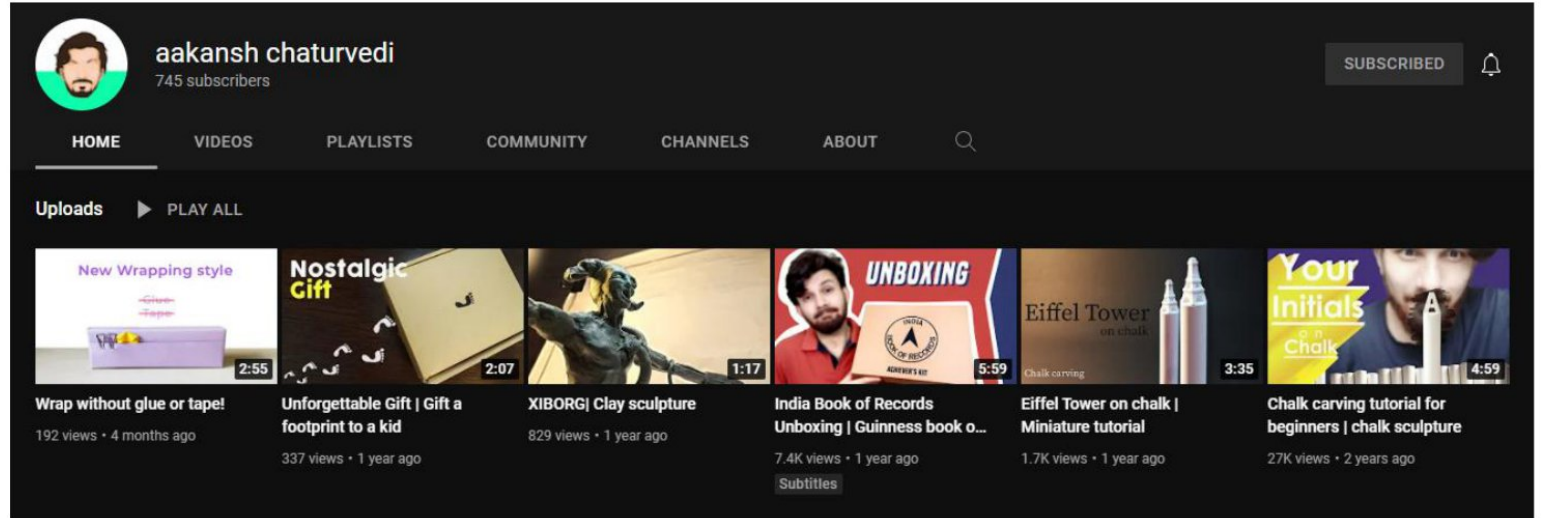

Fig 45 . User 2 profile

Name : Aakansh Chaturvedi

Channel name : aakansh chaturvedi

Location : Khandwa , MP



Recording Space
Indoor



Camera Angles
2



Lighting
Natural + External

Recording Device
Mobile - Samsung M51



Equipment used



Microphone



Phone holder with gooseneck



Tripod

Equipment used



Tripod Top Attachment portion



Tripod bottom Mechanism



Phone holder



Mic kept onto the holder



Camera angles used



1. Vertically set camera angle – At a sitting height at eye level

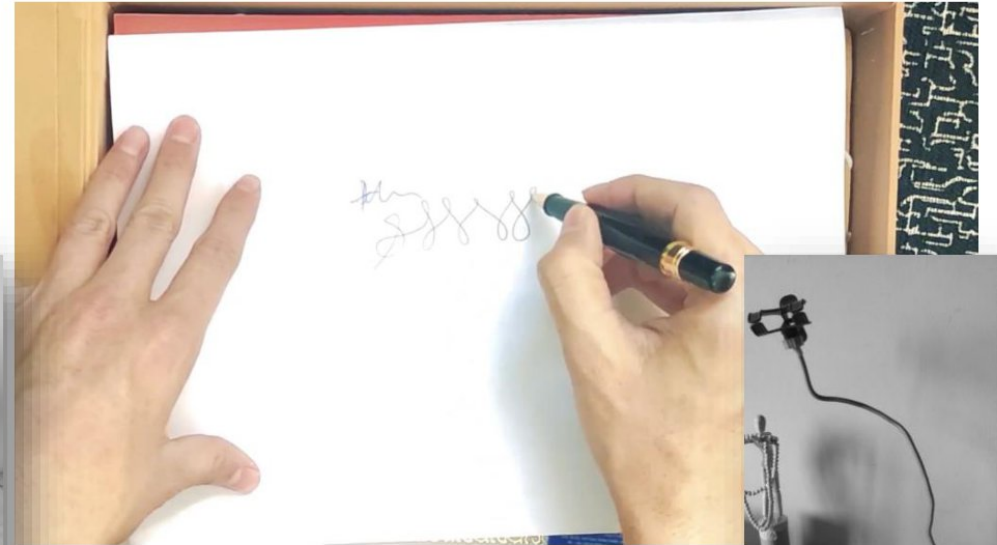

2. View form top (Works on the table)
Using Gooseneck Mobile holder



Fig 48 . User 2 camera angles



Backdrop – Plain Wall



Time taken for whole Setup – 10 mins



Mobile camera used – Back cam Only



Additional helpers – No one

Working Environment

- Sits and Records the Video
- External Lighting
- Natural Lighting
- External Lighting (Used while recording craft work)
- Mobile
- Microphone
- Mic Connected to Mobile
- Tripod



Fig 49 . User 2 Recording environment

Problems Encountered



Remembering the dialogues while recording



Face not visible while talking since using back camera of the phone

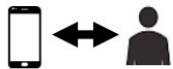

Not able to control the phone from a distance



Storage – No dedicated space for storage and protection



Portability – Shifting the equipment for scene change



Gooseneck Holder – Shakes just after pressing the record button results in a blurry video



4.3 User 3

Music Vlogger



Name : Madhav Gopi Nair

Channel name : Madhav Gopi Nair

Location : Aluva , Kerala

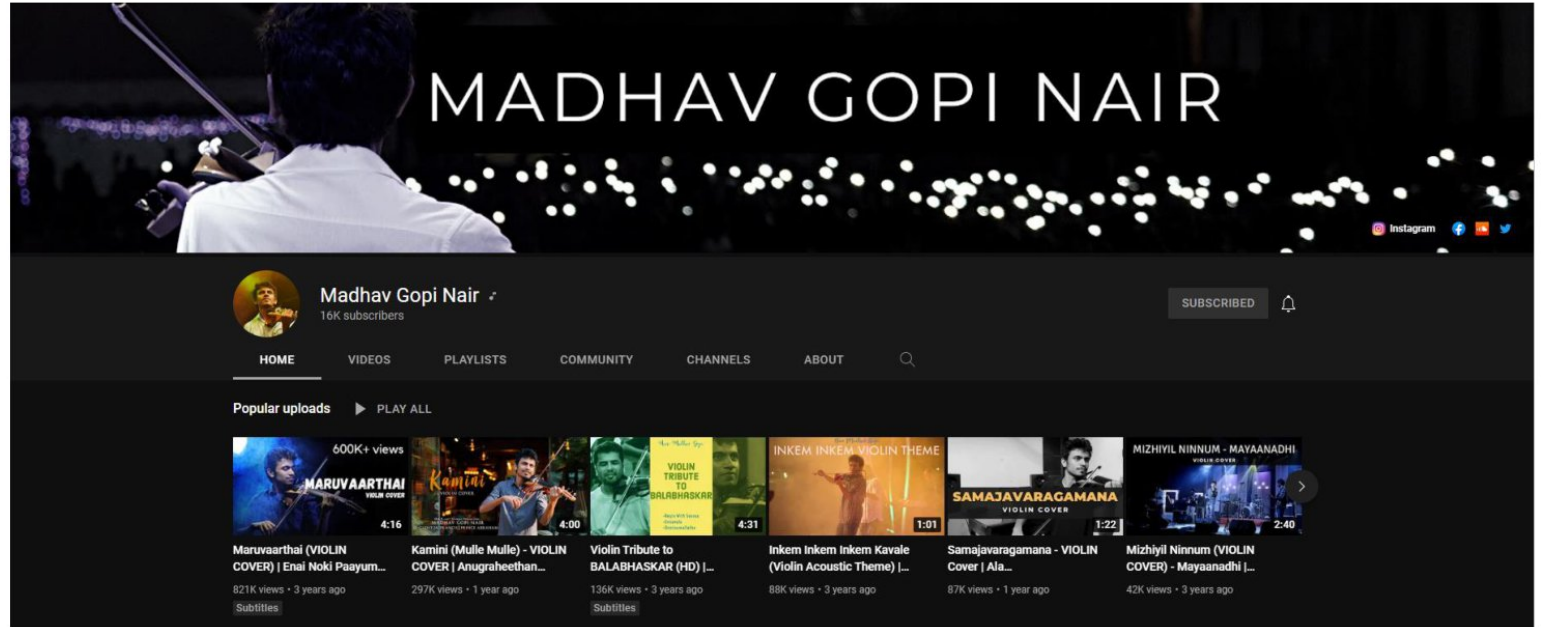

Fig 51 . User 3 profile



Recording Space
Indoor + Outdoor



Camera Angles
Outdoor – Multiple
Indoor – 1



Lighting
Natural + External

Recording Device
Mobile – Iphone 7s
Camera – Canon 1500D





Camera angles used

Indoor



Gooseneck holder attached to tabletop to record



Backdrop – None



Time taken for whole Setup – 10 mins



Mobile camera used – Front cam Only



Additional helpers – No one

Outdoor



Shot with professional videographers – Multiple angles

Outdoor videos are shot professionally from multiple camera angles along with a small crew and are also edited by professionals



Equipment used



Tripod



Phone holder



Attaching Mechanism

Fig 54 . User3 equipment



External Lighting



Holding Stand



Tripod

Fig 55 .User 3 equipment 2

Problems Encountered

Storage issues –

- Big tripods takes up a lot of space
- Shifting it every time to open the door
- Balancing it when fully extended

Setting camera angles –

- Difficulty in finding an attachable surface every time
- Getting correct angles
- Cross verifying the area covered in video , since using back camera for recording.



Fig 56 .User 3 problems

4.4 User 4

Fashion Vlogger

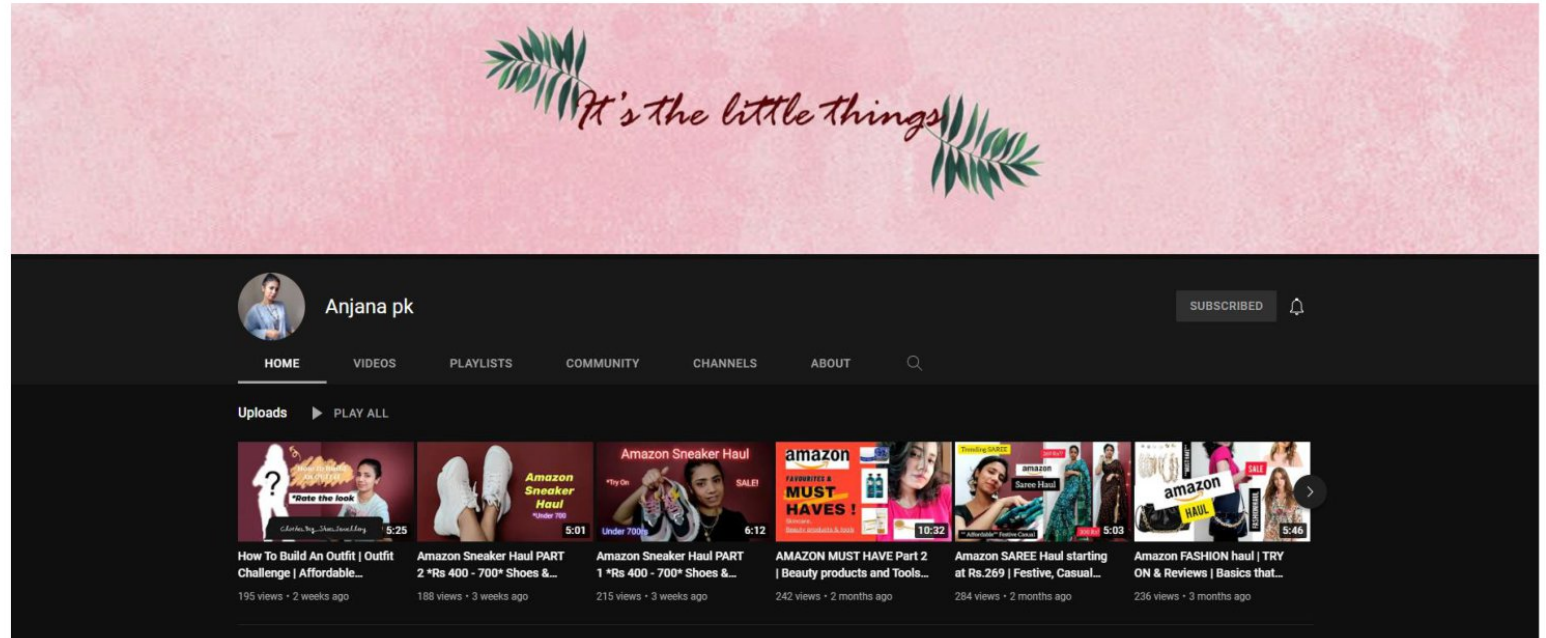

Name : Anjana P K

Channel name : Anjana pk

Location : Calicut , Kerala

Fig 57 . Use 4 profile



Recording Space
Indoor



Camera Angles
1



Lighting
Natural + External

Recording Device
Mobile – One plus Nord



Equipment used



Tripod with Ring light + External phone holder



Tripod



Tripod + Gorilla tripod

 **Camera angle used –**



Vertically set at a height of 150 - 155 cm (Standing and Recording)

Fig 59 . User 4 camera angles



Backdrop – Plain wall



Time taken for whole Setup – 10 to 20 minur



Mobile camera used – Front cam only



Additional helpers – No one

Problems Encountered

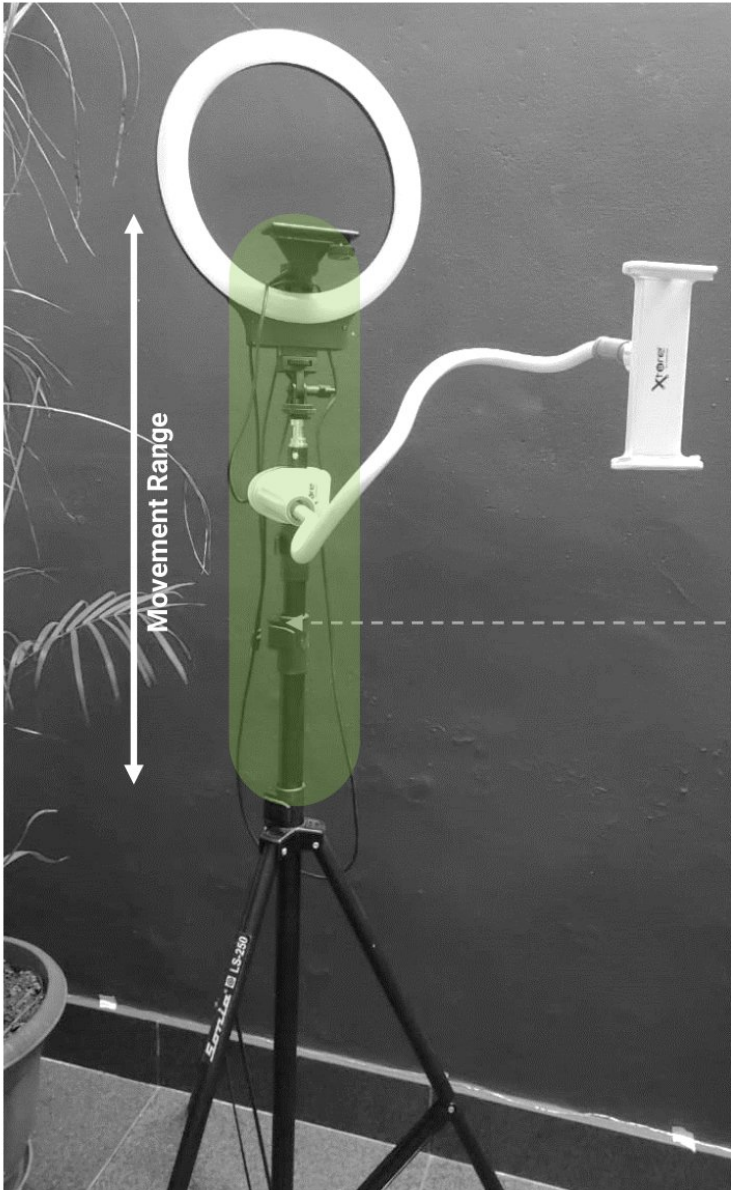

Wishes to take videos while sitting on the floor but light doesn't go beyond a certain height

External phone holder attachment

USB pin should be present in the vicinity

Mic – Stored in a separate Polythene bag
Often misplaced



Takes up a lot of space
(Horizontal and vertical)



Difficult to balance and shift it often to clean the room



Dust accumulation



4.5 User 5

Fashion Vlogger

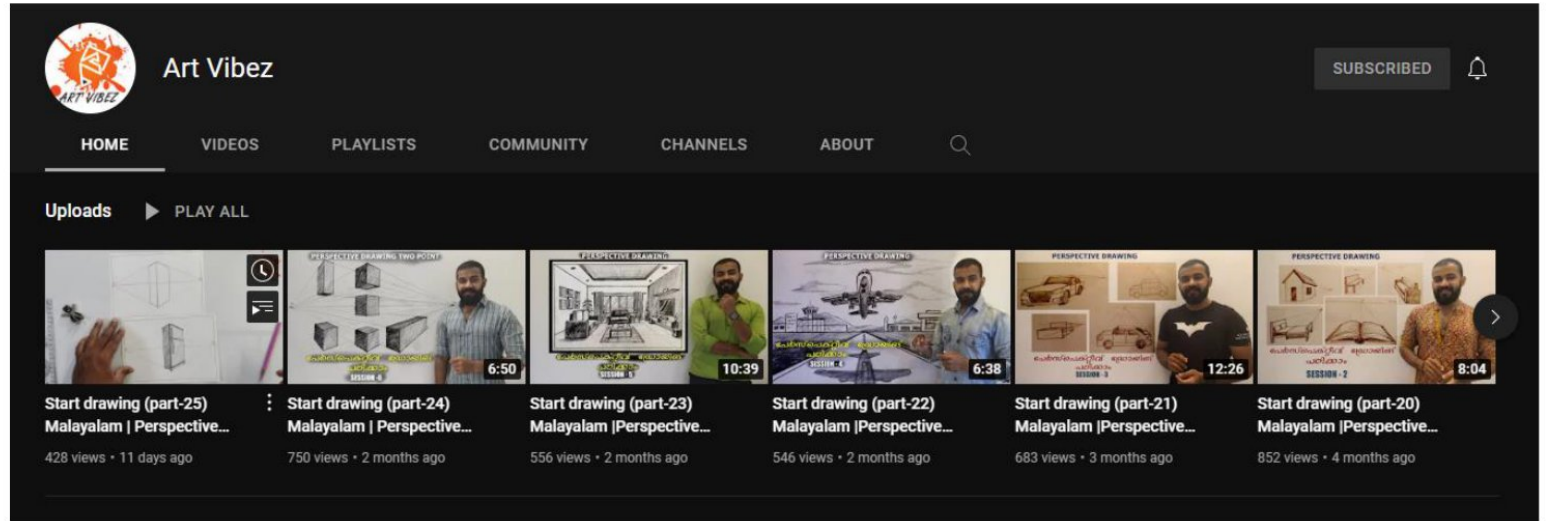

Name : Vikas Bhadra

Channel name : Art Vibez

Location : Kochi , Kerala

Fig 61 . User 5 profile



Recording Space
Indoor



Camera Angles
2



Lighting
Natural + External

Recording Device
Mobile – Redmi Note 9 Pro



Equipment used



Tripod



Self made adjustment

Fig 62 . User 5 equipment



Mobile Holder

 **Camera angles used**

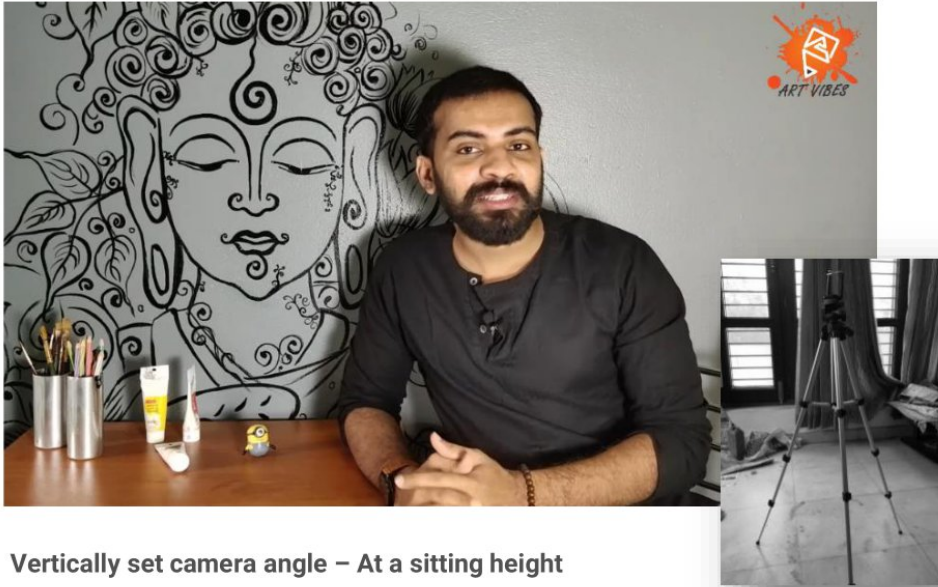

Vertically set camera angle – At a sitting height

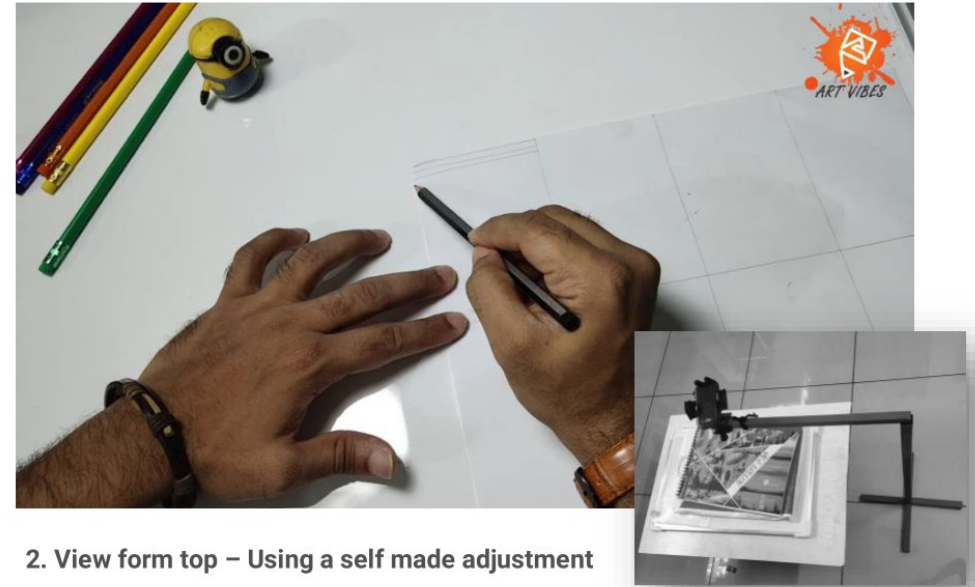

2. View form top – Using a self made adjustment

Fig 63 . User 5 camera angles

 **Backdrop – Painted Wall**

 **Time taken for whole Setup – 15 mins**

 **Mobile camera used – Front cam for introduction , Back cam for drawing tutorials**

 **Additional helpers – No one**

Problems Encountered



Top view Recording – Made own arrangement



Heavy



No height adjustability options



Not suitable for a longer table



Darker shadows due to improper lighting

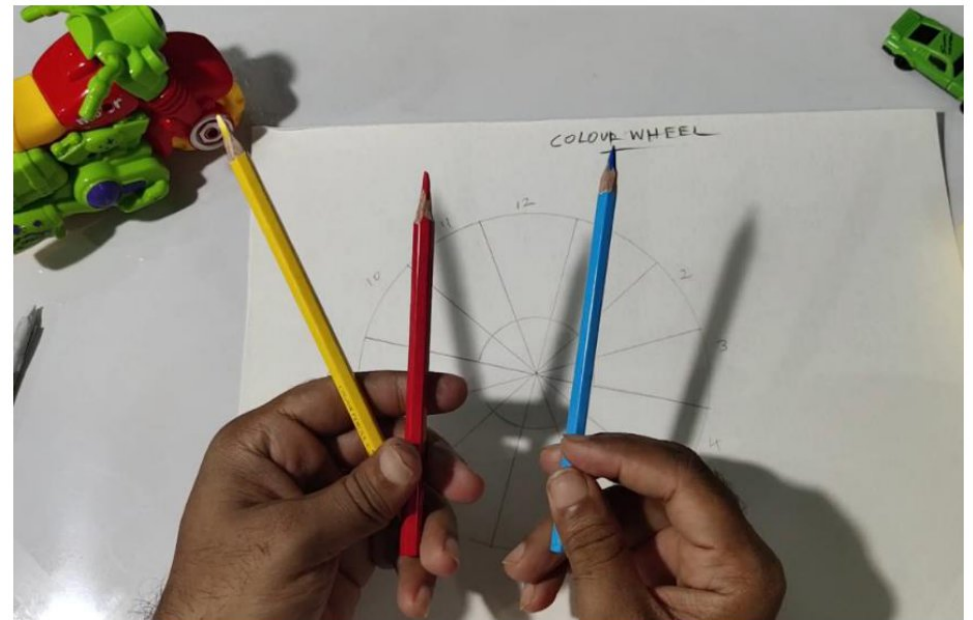

4.6 User 6

Travel Vlogger

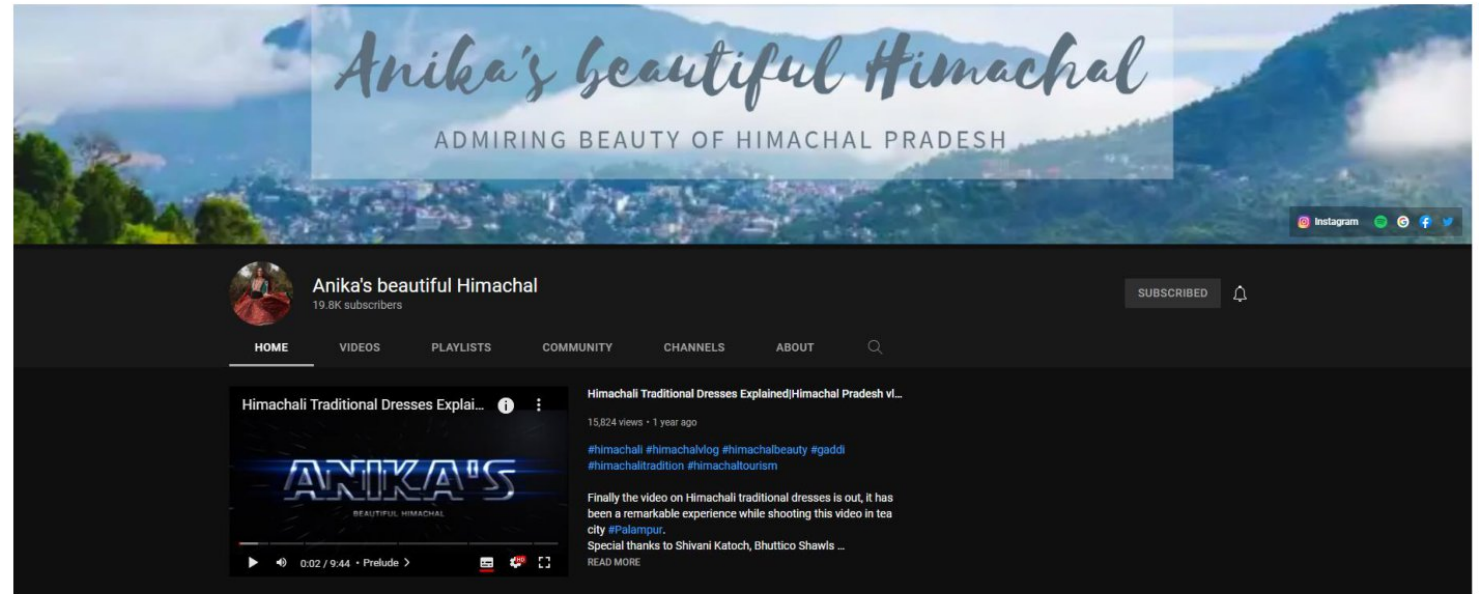

Fig 65 . User 6 profile

Name : Anika Sharma

Channel name : Anika's beautiful Himachal

Location : Himachal Pradesh



Recording Space
Indoor + Outdoor



Camera Angles
2



Lighting
Natural + External

Recording Device
Mobile – Samsung F41



Equipment used



Tripod



Tripod cum Selfie stick

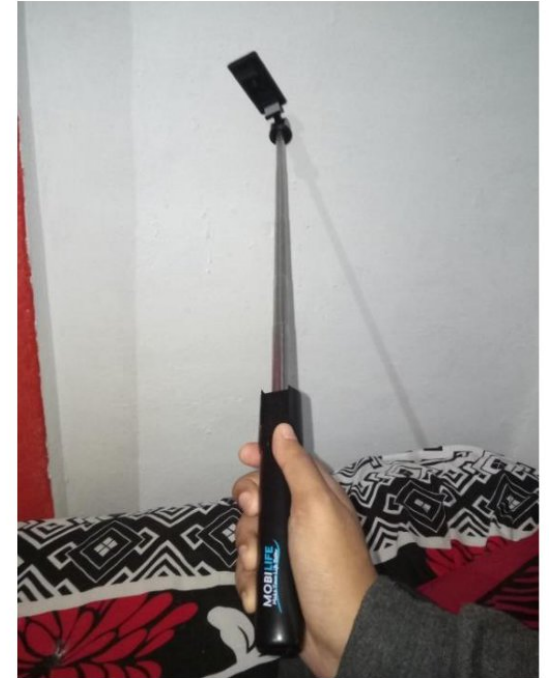

Fig 66 .User 6 equipment

Equipment used



LED Panel Lighting



Self made reflectors

Fig 67 .User 6 equipment 2

 **Camera angles used**

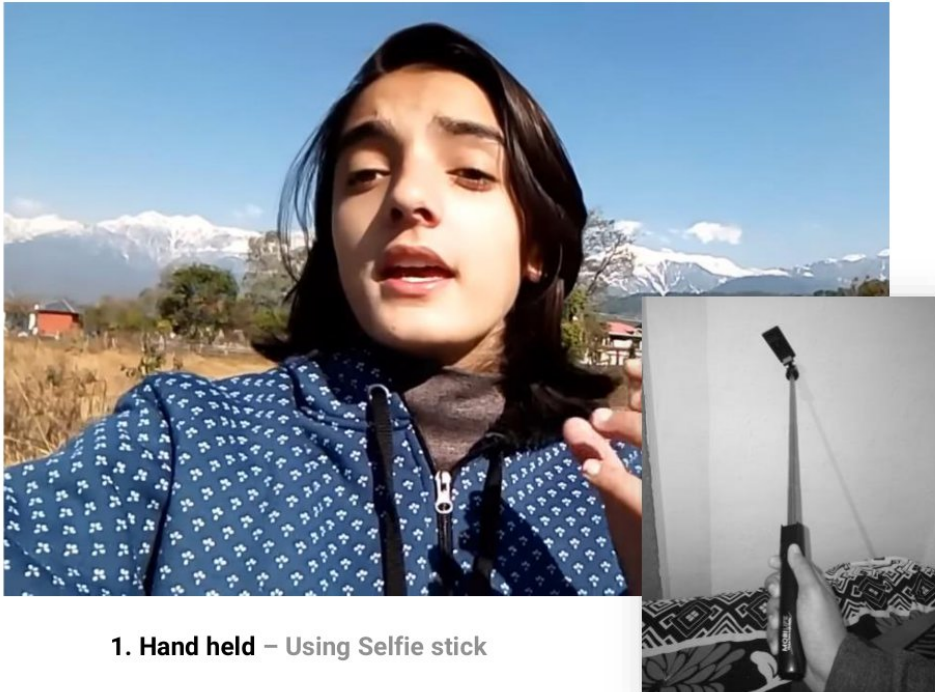

1. Hand held – Using Selfie stick

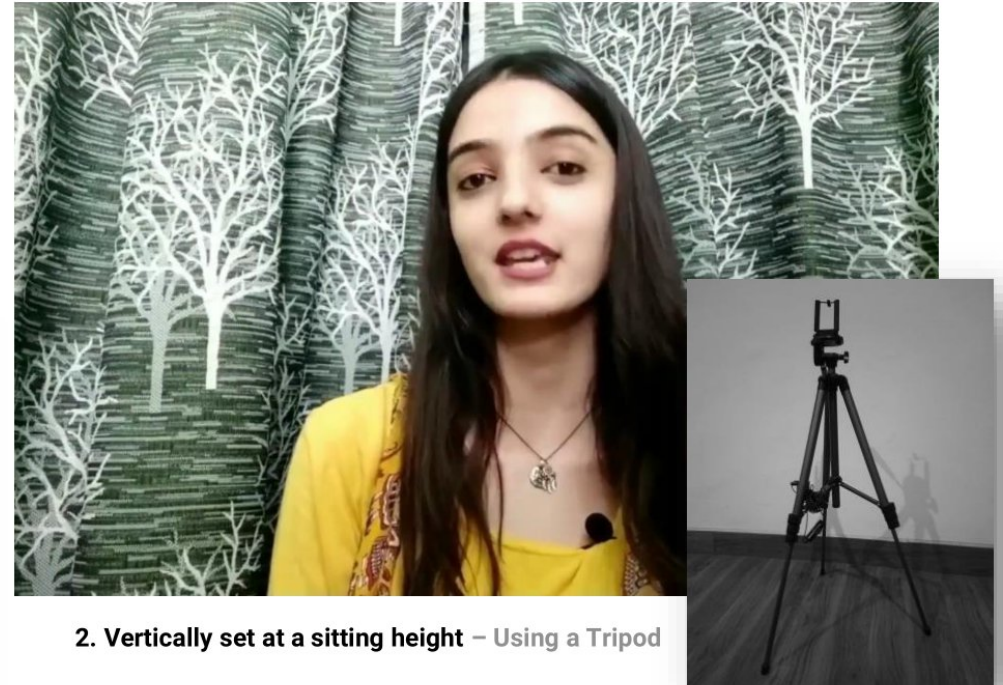

2. Vertically set at a sitting height – Using a Tripod

Fig 68 . User 6 camera angles

 **Backdrop – None (Outdoor) , A printed Curtain (Indoor)**

 **Time taken for whole Setup – 5 Mins**

 **Mobile camera used – Front cam when using Selfie stick , Back cam while using tripod**

 **Additional helper - None**

Problems Encountered



The tripod cum selfie stick was not very stable when the surface was uneven

It would fall down easily as its centre of gravity gets easily shifted

The user had to use additional self made reflectors as she found that the light from the LED was not enough

Fig 69 . User 6 problems

4.7 User 7

Food and Recipe Vlogger

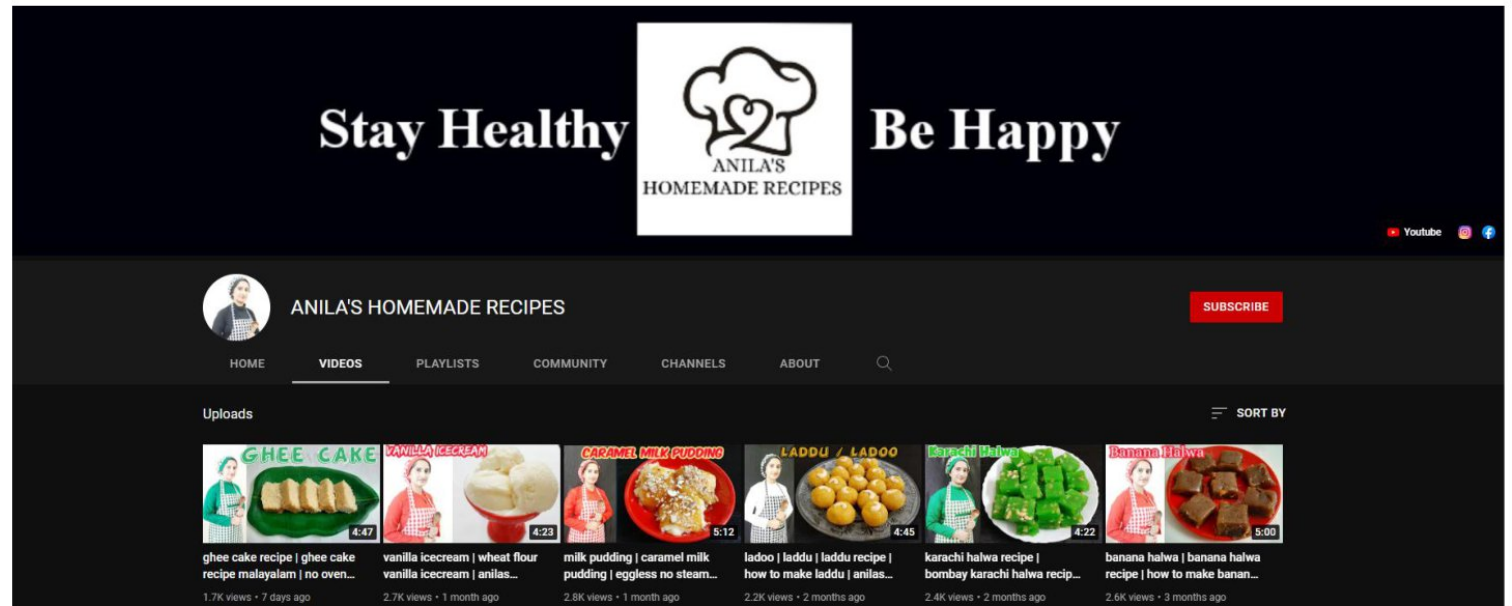

Fig 70 .User 7 profile

Name : Anila Justin

Channel name : ANILA'S HOMEMADE RECIPES

Location : Kerala



Recording Space
Indoor



Camera Angles
2



Lighting
External

Recording Device
Mobile – Redme Note 11 pro





Major Camera angles used



Vertically set camera angle – At Eye Level



Panning the cam using hand



Washing scenes from an inclined angle



Cutting / Chopping or preparation scenes



Shooting stove from top



Grinder scenes



Major Camera angles used



Baking scenes



Freezer scenes



Serving

Fig 72 . User 7 camera angles 2

It was observed that in cooking videos a lot of camera angles were required and the user frequently needed to shift the camera from place to place after shooting each scene. Sometimes even camera panning was required while introducing the ingredients or finally serving the dishes. In the starting, user takes an introduction scene where the camera is steady and facing the user. After that the process starts and the camera angles shift constantly. a

Problems Encountered



Had to make a self made adjustment for holding the phone in Arial view



Top view – Fumes interferes with the camera lens



Requires constant shifting of the camera –
At least 4 different positions during a recipe on the kitchen
Top itself

- Channel Introduction scene
- Introducing the ingredients
- Washing the ingredients
- Preparation (Cutting , Chopping etc)
- Cooking (recording the stove from top)
- Baking / Freezing ? Grinding scenes
- Serving in dishes



Difficulty in operating the phone – Since hands get wet and dirty



Additional person required for operating the mobile























Risk of toppling the set up over the dish or stove



Fig 73 . User 7 problems

4.8 Problem Analysis

The various problems of each categories were carefully analyzed and grouped on table in order to identify the categories which faced the most number of problems

Arial View Shooting	 Art and Craft	 Food and Recipe	 Music	
Lighting and Shadow issues	 Art and Craft		 Music	 Fashion  Travel and Lifestyle
Height adjustability of Tripod/ Ring Light	 Art and Craft	 Food and Recipe		 Travel and Lifestyle
Frequent shifting and Camera angle Requirements		 Food and Recipe		 Travel and Lifestyle
Storage issues	 Art and Craft	 Food and Recipe	 Music	 Fashion
Portability	 Art and Craft	 Food and Recipe		 Fashion
Additional person required		 Food and Recipe		

Upon analysing the data it was found at the most number of problems were faced by cooking video makers and followed by arts and craft video makers. So it was decided to focus more on these type of content creators.

05. Market Study

The type of gadgets and devices available for mobile videography in the market were carefully studied



Fig 74 . Market study

Basic Equipment used by YouTube **Content Creators**



Fig 75 . Camera and mobile

Camera / Mobile



Fig 76 . Tripod and gimbal

Tripods / Gimbals



Fig 77 . Tripod with lighting

LED or Ring Lighting Mechanisms



Fig 78 . Microphone

External Microphones



Fig 79 . Diffuser light

Soft boxes



Fig 80 . Bluetooth comptrroller

Camera remote

Types of Tripods

Aluminium Tripod



Fig 81 . Al tripod

These are portable tripods that may be used with cellphones, digital cameras, and pocket cameras. It has a three-way rotating head that can be rotated 360 degrees. It's composed of high-quality aluminum alloy, so it'll last a long time, and it has a non-slip rubber foot pad. It has three extendable pieces that may be raised to a height of 50 inches.

Gorilla Tripod



Fig 82 . Gorilla tripod

This tripod is composed of high-quality ABS, which means it will outlast other plastic tripods. It can be used with a smartphone, GoPro, or DSLR camera. It includes an anodized revolving sphere as well as a precise angle lock. It has a maximum load capacity of 1kg and a maximum height of 240mm. It is very flexible due to the anti-slip elastic material. It comes with a Bluetooth remote that makes taking images a breeze..

Mini tripod



Fig 83 . Mini tripod

It works with smartphones, GoPro cameras, and most DSLR cameras. It has a screw connector on the ball head and a maximum operating height of 7.87 inches. It has anti-skid rubber feet that keep it steady and can support up to 1 kg of weight. If you want a tripod that you can simply pack in your suitcase, this is a fantastic choice.

Long legged tripods



Fig 84 . Long legged tripod

These tripods have 4-tube section aluminium legs that extend to a maximum height of 136cm. This little tripod is ideal for use with smartphones, compact cameras, and most DSLRs. It has a 3-way pan head and a quick release plate, so it's suitable for a wide range of photographers. A level tester is also included with this tripod, which might be beneficial when the ground is not level.

Flexible tripods



Fig 85 . Flexible tripod

These tripods are is comprised of ABS, which makes it sturdy and long-lasting. It includes a revolving sphere with anodized finish to ensure it can withstand weight. It may be used with smartphones, pocket cameras, GoPro cameras, and DSLR cameras. It comes with a sturdy smartphone holder that allows you to mount your phone.

Types of Tripod heads

Ball head



Fig 86 . Ball head

It moves around using a ball structure, as the name suggests. You may see a spherical ball resting in a groove on any ball head, and the ball will have a piston at one end that connects to the mounting setup. Manufacturers use different mounting methods. It's one of the most popular tripod heads on the market. You may put your camera in practically any angle thanks to the ball structure.

Pan and tilt tripod head



Fig 87 . Pan and tilt

Pan and Tilt heads are a fantastic alternative if you don't want to use various angles and want to limit your camera movement to two axes. There will be two handles, one for horizontal movement and the other for vertical movement. If you wish to move the camera horizontally, lock the tilt head and loosen the pan head, then move the camera around. Lock the pan head, loosen the tilt head, and adjust the tilt handle for vertical movement.

Gimbal head



Fig 88 . Gimbal head

If you're photographing wildlife or birds, you'll want to use the 500mm and 600mm super telephoto lenses. If you're using a tripod, you'll need to acquire the correct balance and stability with your camera and lens combo to get the photo. As a result, you'll need a Gimbal head for your tripod. Gimbal heads are available in a variety of price points. To get a perfect balance, you need to align the camera and lens combination in the center of

Fluid head



Fig 89 . Fluid head

The fluid head is the appropriate tripod head if you want to capture videos alongside your images or if you are a committed cameraman. Fluid heads are a type of Pan and Tilt head that uses a hydraulic damping mechanism to provide smooth and consistent shots. Fluid heads let you to change the friction, allowing you to achieve the desired pan speed. If the movement isn't smooth, the audience will notice jerks in your video, which might be distracting. When compared to other tripod heads, fluid heads are more expensive.

Motorized tripod head



Fig 90 . Motorized tripod

A motorized tripod head might be a wonderful addition to your camera set if you're shooting panoramic photos or time-lapse recordings. This tripod head uses a battery-powered motor to achieve precise movement, as the name implies. The majority of them are powered by a rechargeable battery, and you can control the speed and precision with inbuilt controls on the head. Some high-end models even include a smartphone application that allows you to change these parameters and control it remotely. The payload capacity of a motorized tripod head is the most important factor to consider when purchasing one. It must be capable of supporting the weight of your camera. Heads with motors are available..

Tilt head



Fig 91 . Tilt head

A tilt head can be a wonderful alternative if you use a monopod for your photography. They're made exclusively for monopods. With a tilt head, you can only move vertically. You must spin the monopod in your hand for horizontal movement. You don't have to depend on the head for the pan movement. There are mechanisms in place for them.

Pistol grip head



Fig 92 . Pistol grip

A ball head with a pistol grip is known as a pistol grip head. Is it just a matter of changing the handle? No, pulling the trigger button on the handgun allows you to control the ball joint tension. Remove your fingers from the trigger button when you're satisfied with the camera position, and the head will be fixed in that position. There aren't many photographers who use pistol grip heads.

Panoramic tripod head



Fig 93 . Panoramic head

Meant for panoramic photographers who doesn't want to spend the money on motorized heads, regular panoramic heads are the way to go. The tripod head allows you to move the camera horizontally in this case. The camera movement angle will be marked in degrees on the base plate. As a result, you can snap individual photographs and stitch them together afterwards to create a panoramic image.

Three way heads



Fig 94 . Three way

A three-way tripod head is a great choice if you want to move your camera with precision. It works in the same way as a ball head, allowing you to position your camera in all three axes. A three-way tripod head, on the other hand, will assist you in achieving a perfect position. If you want to perform the same thing with a ball head, you'll have to do a lot more experiments. Three lever handles will be used to control the three axes separately. The biggest downside of this sort of tripod head is that it takes a long time to place the camera.

Most commonly used Equipment



Tripods whit light and microphone attachment



Tripods whit ring light



Holder and microphone



Typical tripod



gimbal



Mini tripods

Fig 95 . Commonly used equipmernt

Gorilla Tripod with Bluetooth Controller

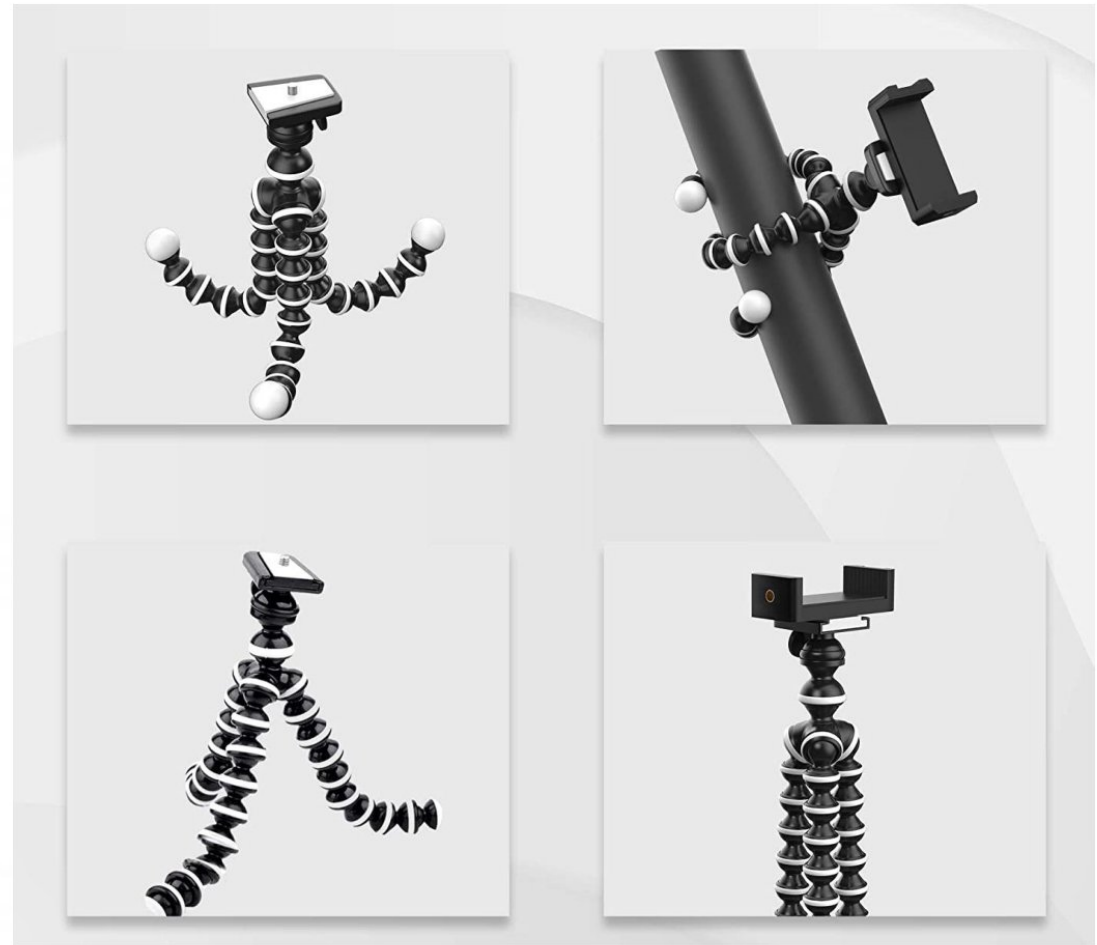

Flexible and can be easily attached anywhere

Fig 96 . Gorilla tripod

Rotatable Design



Can be set at Different Angles

LED Ring Light Support USB Charging



Fig 97 . Tripod with light

Equipment Details – Gooseneck Mobile holder



- Material – Silicone
- Mounting type – Table top
- Weight – 320 g
- Special features – Flexible , Gooseneck , adjustable arm



Fig 98 . Gooseneck tripod

06. Initial **Design Brief**

To make a **Customized Vlogging kit for YouTube Content Creators** which would suit their **Content making requirements** and would make the **Storage and Portability** much easier .



6.1 Area of Focus

As it was found that the art content creators as well as food recipe content creators face the maximum number of problems the design objective was taken forward by considering these 2 cases in particular . For deeper understanding of their recording environments , secondary research was performed.

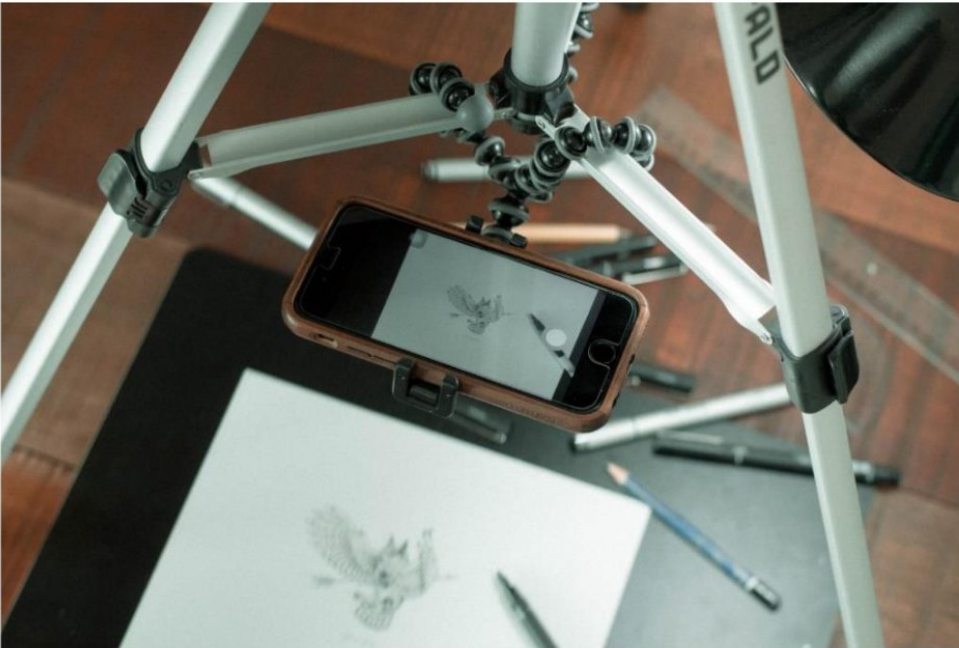

Fig 99 . Artist view

Art Content Creators



Fig 100 . Recipe view

Food and Recipe Content Creators

7.1 Primary Research

User journey Map

A Typical YouTube Video uploading occurs in 3 stages. They are -

- Preparation
- Recording
- Post processing



Preparation



Recording



Post Processing

Stage 1 Preparation

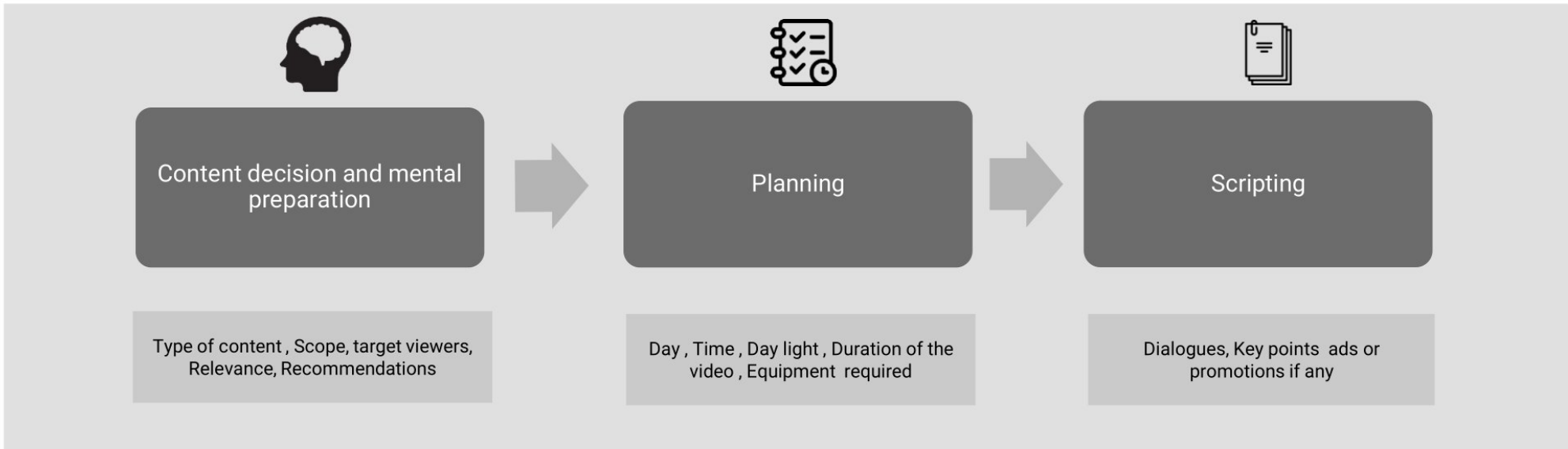

The Steps in this stage are the **same for both artists as well as Food Recipe Vloggers**

Stage 2 Recording

In the recording stage things are different. Compared to Recipe vloggers artist have lesser number of steps involved. They have to record from 2 different angles only. In between the videos they can be mistakes and the video often needs to be shoot again.



Art and Craft Vloggers



RECORDING

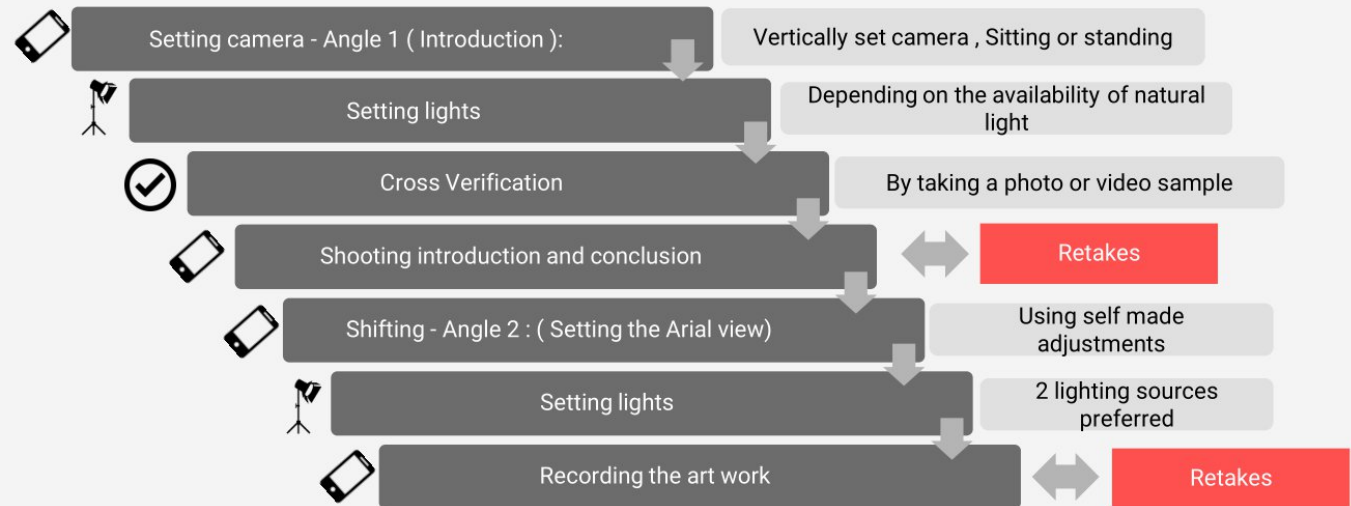

Stage 2 Recording

For the Food and Recipe content creators the recording stage itself has 2 sub stages. One is steady recording and the other is frequent camera shifting and recording.



Food and Recipe Content Creators

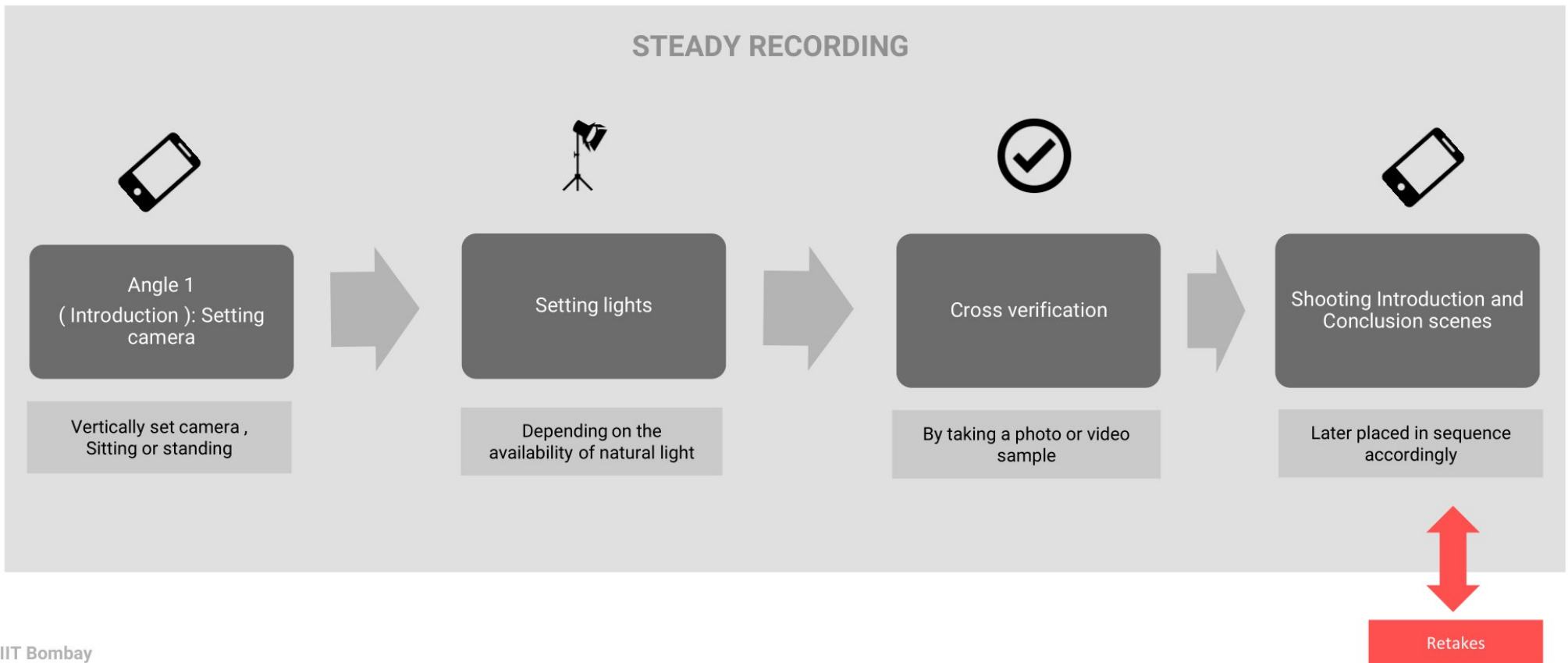



Food and Recipe Content Creators

FREQUENT CAMERA SHIFTING AND RECORDING

Optio

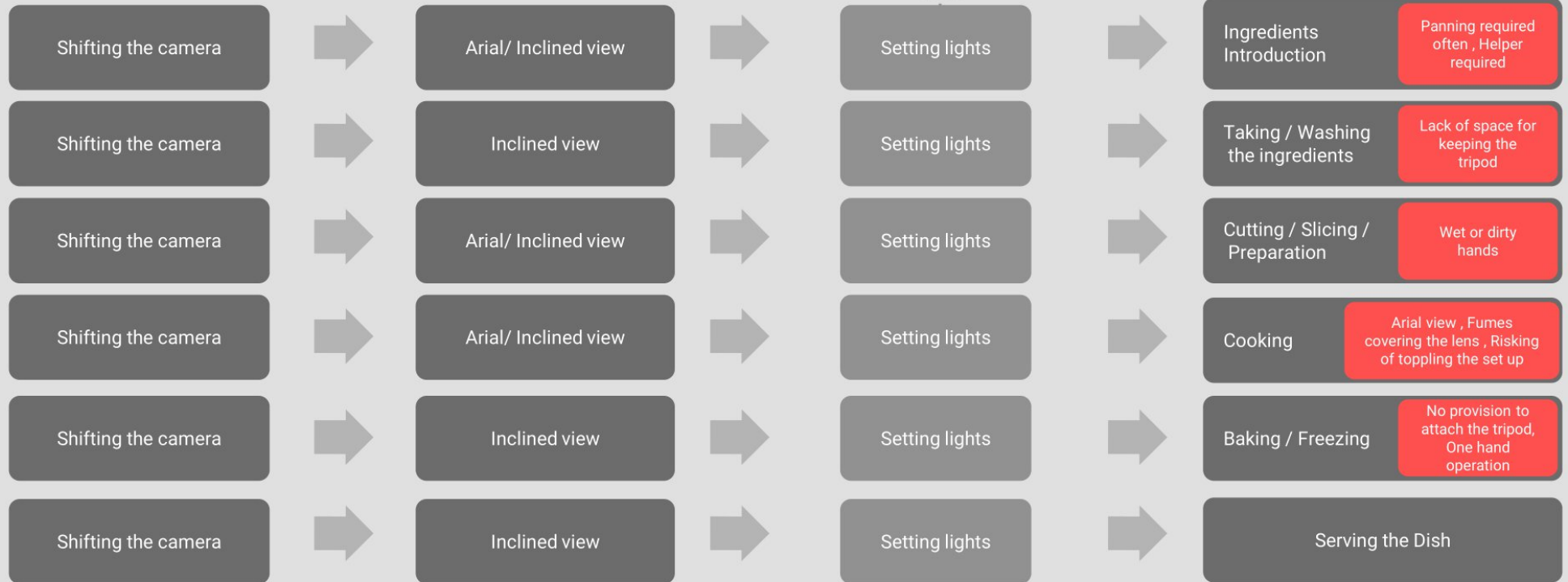

Stage 3 Post Processing

This is the last stage once the shooting process is complete and the video is ready to be uploaded . This stage is also common for both the type of Creators



POST PROCESSING



Data transferring

USB , Drive transfer



Editing works

Activities – Arranging clips , selecting best video clips form retakes, adding voices , amplifying or de amplifying voices, adding background music, reducing noises, adding subtitles , short notes, links, descriptions, thumbnail , meme contents if any.

Softwares - Premier pro , Filmora , Inshot, Kinemaster etc

Done by – Children or husband or relatives in most cases



Uploading

Video resolution – 1080p in most cases.

Ideal Lighting for shooting Art works

The picture shown below shows the ideal shooting conditions for a good art work video. From the top and side views it can be seen that the light should be coming at an angle of 45 degree from both sides so that minimum shadow occurs and proper lighting of the scene is obtained. When the light comes from the top or there is only one source of light sharp shadows are formed making the video unpleasant.

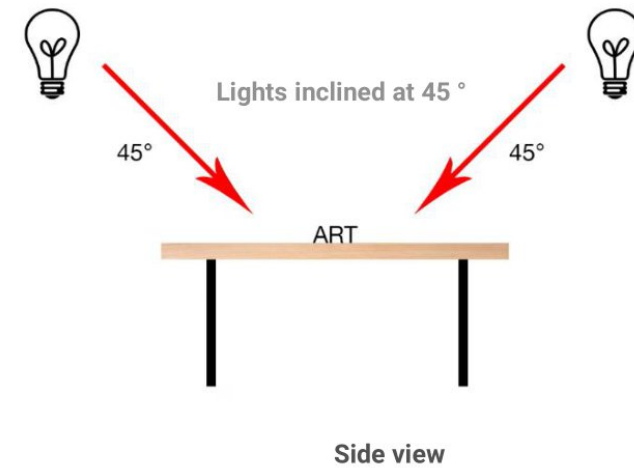
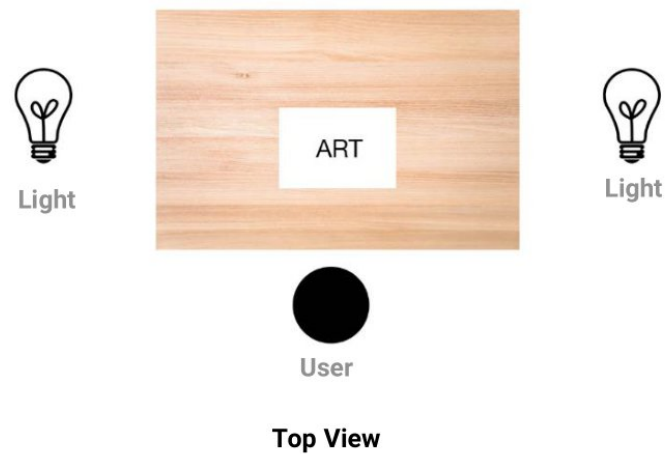

The following picture shows the ideal setup of a professional artist with the lights are coming exactly at 45 degrees. In addition to this there is a top light also illuminating the scene and ensuring that the shadows are dispersed evenly and video comes out well.

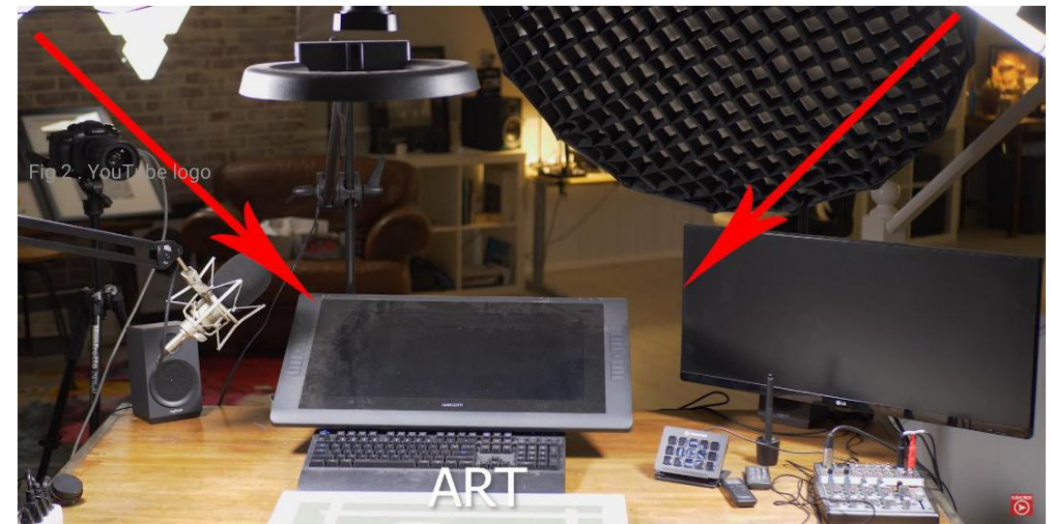

Fig 101 . Professional artist vlogging table

Additional Problems



Fig 102 . Artist problem

The picture shows an artist trying to capture his art work using a mobile phone . it can be clearly seen that the menu ability of his hand is limited by the presence of the tripod and he's trying to shoot the video in Arial view.

Thus a typical tripod is unfit for this purpose as the user has to shoot the video from the top view.

7.2 Kitchen Types

Single Walled Kitchen

Old-fashioned and classy! Straight modular kitchens, on the other hand, are extremely convenient and simple to use. This kitchen layout allows for ample storage of all of your accessories and essential features. This concept clings to the basics and is a must-have for individuals who want simple aesthetics, as well as the convenience of cooking and dining.



L Shaped Kitchen

This form is best suited to small to midsize kitchens. To keep an L-Shape modular kitchen clutter-free and orderly, careful planning is required. In an L-shaped modular kitchen, creativity soars. The L-Shaped kitchen is ergonomically sound and creates a useful work triangle for food prep, cooking, and cleanup. Because this layout type necessitates an outstanding floor plan, this sort of kitchen design can be suited to any decor. The kitchen must be built at the corner where two walls make a perpendicular angle for an L-shaped design to operate. In addition, one section of the wall must be twice as long as the other.



U Shaped Kitchen

Three walls of a U-shaped modular design are lined with cabinets and appliances. This style of kitchen is a space-saving design that saves you money. It is the most practical kitchen layout and gives a lot of storage and appliance space. The 'Golden Triangle' design works well with a U-shaped modular kitchen because the fridge, sink, and burners are all within easy reach. This is a useful use of kitchen space that may be more difficult to execute in L-shaped kitchens and other galley kitchens. The most important benefit of a U-shaped modular kitchen is the safety component, as traffic will not impede your productivity.



Gallery Kitchen

Two narrow rows of cabinets facing one other with a tiny passageway in between constitute a galley modular kitchen. The galley plan complements any kitchen decor and improves cooking safety and efficiency. This style of kitchen layout can include multiple cupboards as well as doorways or walks at either end. All important appliances are stored in tall cupboards that run down the wall. To make the upper cabinet more connected to the ceiling, use a lighter color for the base cabinets and a heavier, darker substance for the base cabinets. This will also help you feel less like you're in a corridor. To make the area look more organized, try hiding the refrigerator and dishwasher behind cabinet panels.



Island Kitchen

An island-shaped kitchen accommodates all functionalities in a smart manner, spanning the full cooking area. It provides the host and visitors with a choice of comfort alternatives. Kitchen layouts with islands provide additional space for children to play and conduct homework, as well as making the kitchen a versatile environment. It also has greater storage space and is more well-ventilated



7.3 Self-made solutions

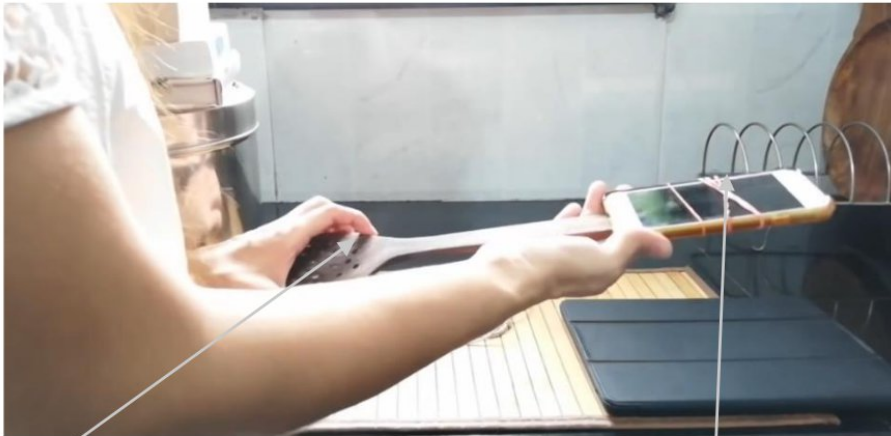

Phone attached to a
Wooden Serving spoon

Rubber band

Fig 108 . Self made phone attachment



Heavy lid

Container and
book

Background sheet

Fig 109 . Phone holder made

In order to get a top view view the user had tied the mobile phone to a wooden serving spoon using rubber bands. A tin can and few books are used to attain the required height and the mobile phone is supported by heavy lid to record from the top.



Fig 110 . Kitchen set up



Here another user can be seen using a suction holder to hold the mobile in the top view and also using a tin can to hold a gorilla tripod which shoots the cooking at an inclined angle. While shooting from the top from using this suction cup setup, the user is forced to change the views manually every time and shift the mobile to the required positions. This setup is also highly dependent on the availability of a shelf on top. In the absence of a shelf the user cannot fix the mobile in the required position. Also the tin and tripod combination takes up a lot of space on the kitchen top, limiting the workability of the user.

PVC Pipes with
L and T joints used

Camera translation in
horizontal plane

Bulbs fitted with tracing
sheets used as diffuser

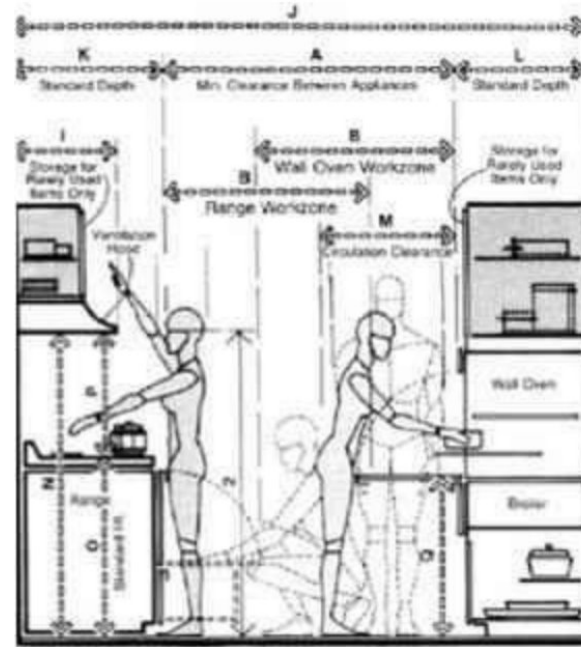
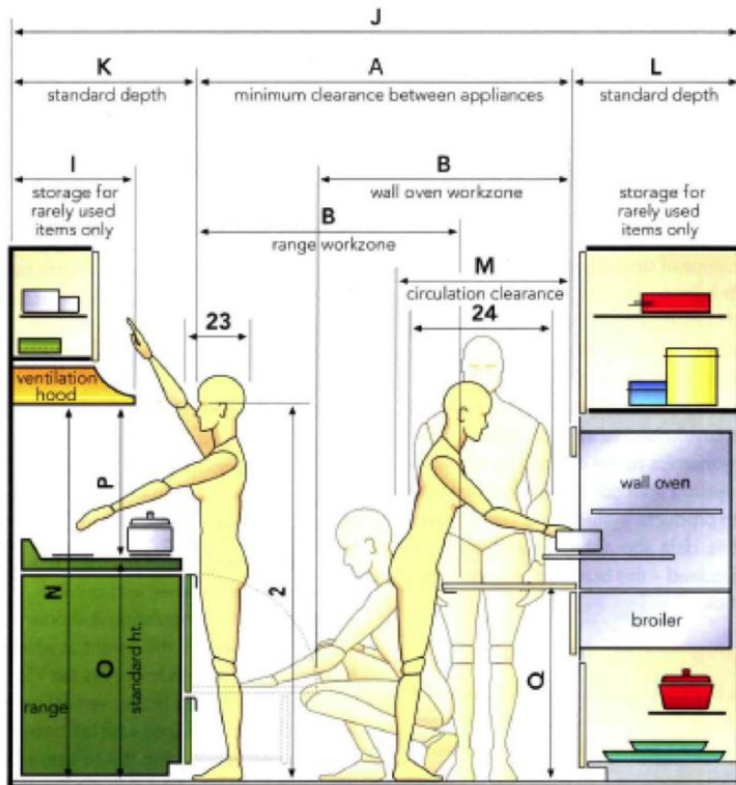

Fig 111 . Self made camera set up

The figure shows an innovative solution done by a user to tackle the difficulties in recording from the top. She has made a camera setup herself with the help of PVC pipes . The camera can move in both horizontal as well as vertical plane and record the video. L and T joints are used here to connect the PVC pipe and help in translation. She has used 4 bulbs for the lighting and covered them with filter papers to make the lighting diffused.

7.4 Kitchen anthropometry

The anthropometry dimensions of kitchen were carefully studied in order to understand the walkable area, the camera placement and user interactions happening.



RANGE CENTER

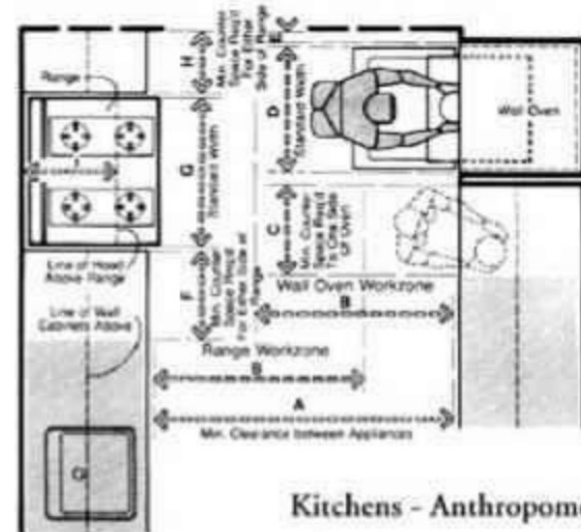

	in	cm
A	48 min	121.9 min
B	40	101.6
C	15	38.1 min
D	21-30	53.3-76.2
E	1-3	2.5-7.6
F	15 min	38.1 min
G	19.5-18	49.5-116.8
H	12 min	30.5 min
I	17.5 max	44.5 max
J	90-101.5	230.0-257.8
K	24-27.5	61.0-69.9
L	24-26	61.0-66.0
M	30	76.2
N	60 min	152.4 min
O	35-36.25	88.9-92.1
P	24 min	61.0 min
Q	30 min	76.2 min

Kitchens - Anthropometric Data

Fig 112 . Kitchen anthropometry

08. **Modified** Design Brief

To make a **Customized Vlogging kit for YouTube Content Creators at a beginner or amateur level making Cooking videos or art videos using Mobile phones**

It should -

- Facilitate all the angles and directions intended
- Makes the overall process comparatively easier
- Minimizes the setting up and scene changing time
- Takes into account the storage and portability aspects of the products
- Adds more value to the product
- Avoids any external help if possible



09. Ideations

9.1 Ideation 1

Using End Connectors and String

In kitchen the whole process takes place in different areas ie. Introducing ingredients, cutting them, peeling, cooking , serving etc. So during the process the user has to constantly shift the camera. So the whole set up of camera and lighting can be made to move on a string connected at the ends on the wall.

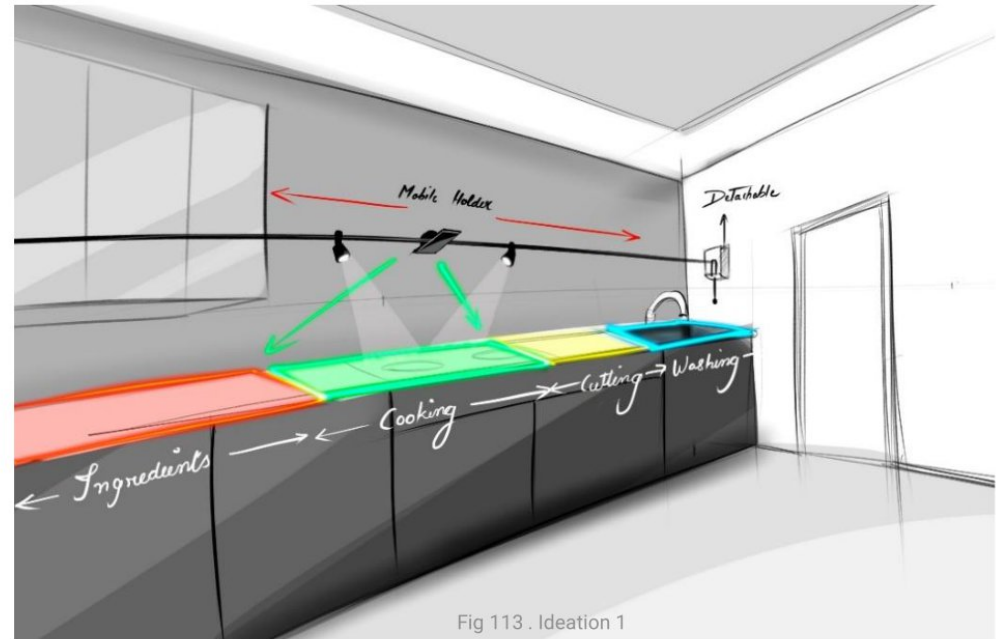

Fig 113 . Ideation 1

9.2 Ideation 1.2

Introducing railings on the end connectors

In the first ideation if railings are also attached to the ends, it will facilitate vertical movements too increasing the value of the product.

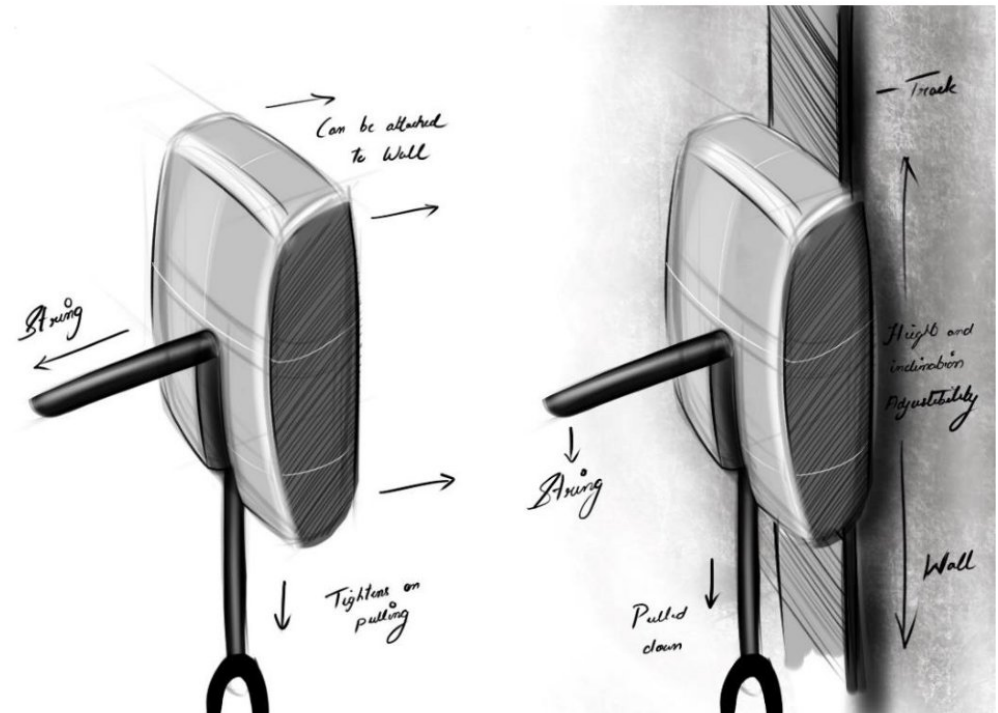

Fig 114 . Ideation 1.2

9.3 Ideation 2

Over the head and Around the Neck holders

This is best suited for cooking video makers. This arrangement can be used to shoot quick and short videos like mixer grinder scenes, opening and closing of freezer, oven etc. This setup doesn't require the use of hands and the user will be able to use both hands for working.



Fig 115 . Ideation 2

9.4 Ideation 3

Artist table

This set up is aimed at bringing the ideal art capturing set up. It has a mobile holder in the center which has a clamping mechanism and can capture top views. It also has 2 lighting set ups running along the sides of the table which is also slid able and height adjustable enabling the user to set it up as per his requirements.

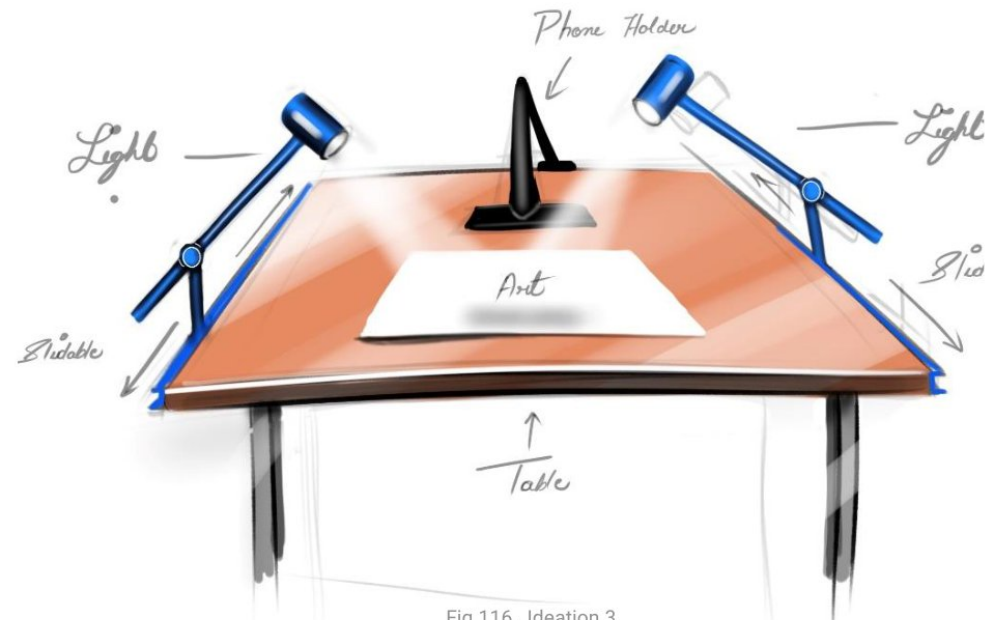

Fig 116 . Ideation 3

9.5 Ideation 4

Window mounted Holder

Here the whole arrangement can be mounted to an adjacent window and it can be adjusted above the table. These are best suited for art and craft vloggers. This set up can make effective use of the natural lighting available. It also has an attached lighting to illuminate the scene in case required.

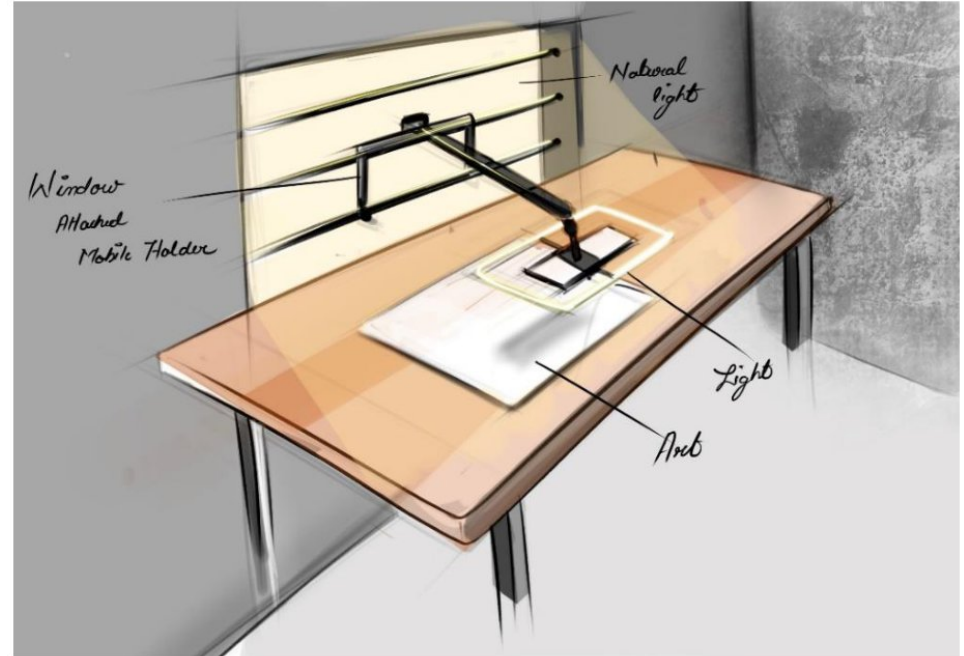

Fig 117 . Ideation 4

9.6 Ideation 5

Using Magnetic Connectors

Here magnets are used to connect the mobile phones to the holders. It is more convenient than screwing it and is much more time saving.

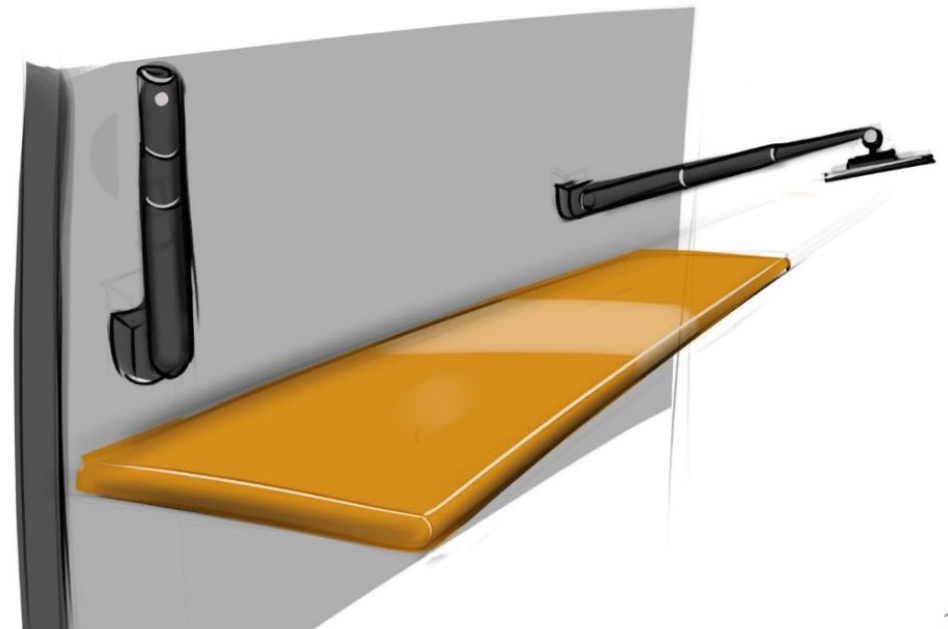

Fig 118 . Ideation 5

9.7 Ideation 6

Splitting tripod

This concept looks and can be used like a normal tripod. But it can have an additional feature that each of its legs are detachable and can be individually attached to a wall surface and have holders attached to all of them. Since the legs already have telescopic adjustable legs it can allow height adjustments as well. So the user can attach them on the wall where he intends to keep them and can use as per his requirements



9.8 Ideation 7

Simple Table lamp Mechanism

This concept will have a simple table lamp like adjustment except the fact that it needs to be screwed onto the wall. The legs are adjustable with hinged joints. The user can align the holder as intended and shoot the videos. This is best suited for artists. This can be used by cooking vloggers as well but may not be able to cover the full kitchen top area.

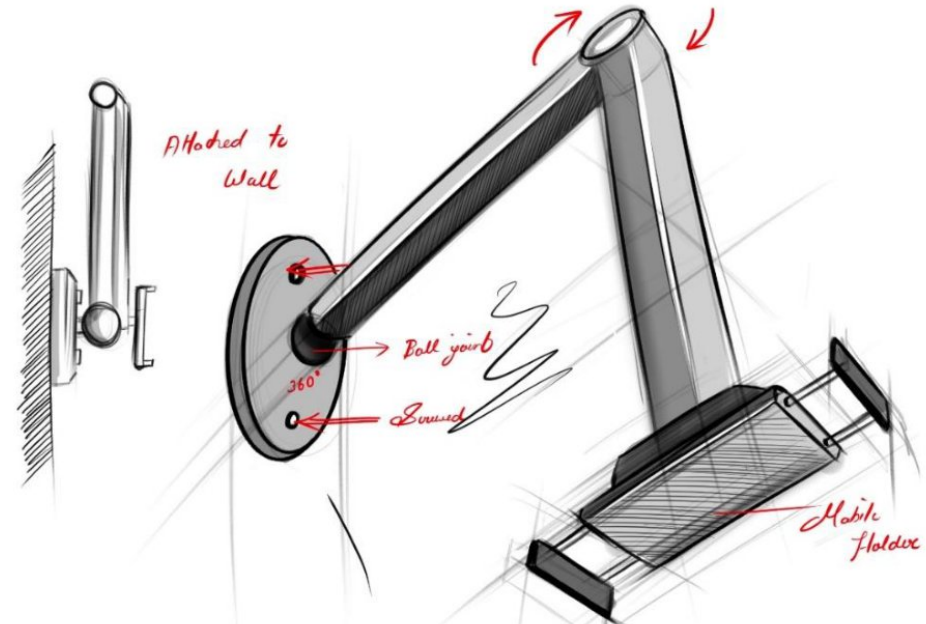

Fig 120. Ideation 7

9.9 Ideation 8

Using Suction cup attachments

This concept will have a rod which is supported at both ends by suction cups and can be attached to the bottom surface of the kitchen shelves. The camera and lighting can run over it and cover the shooting area.

But here the limitation is that the kitchen has different orientations and it might not always have a shelf right above the intended shooting area.

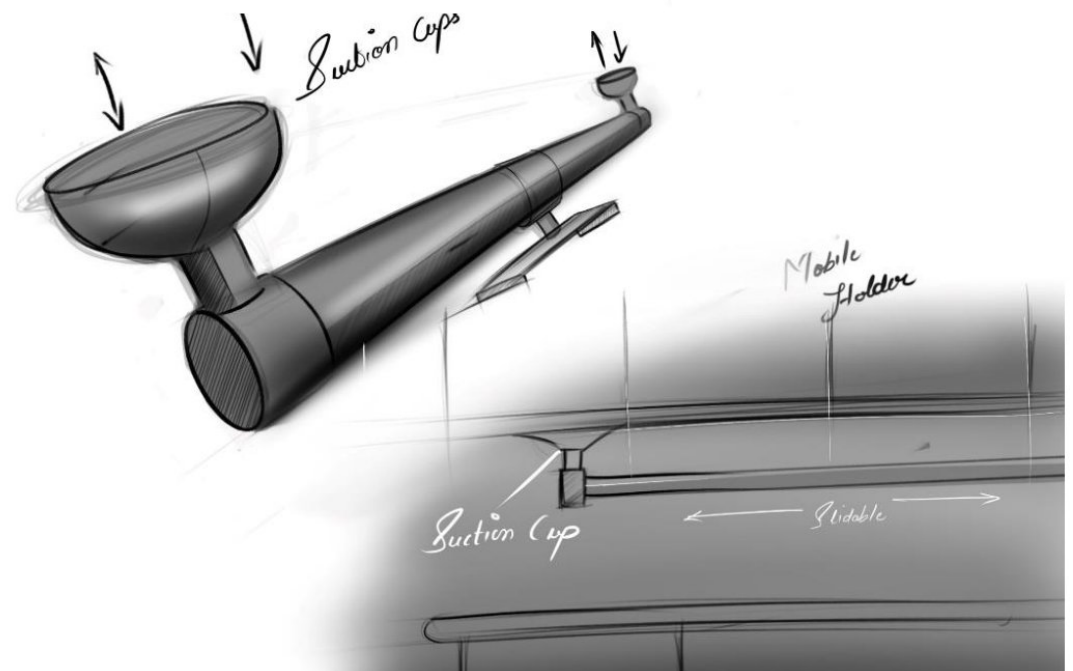

Fig 121 . Ideation 8

9.10 Ideation 9

Using Clamping Mechanism

This concept will have a rod which is attached to the kitchen shelves by slightly keeping it open. This mechanism is stronger compared to the suction mechanism. The camera and lighting set up can run over it. But again this is limited by the availability of kitchen shelves at the top of the intended shooting area.

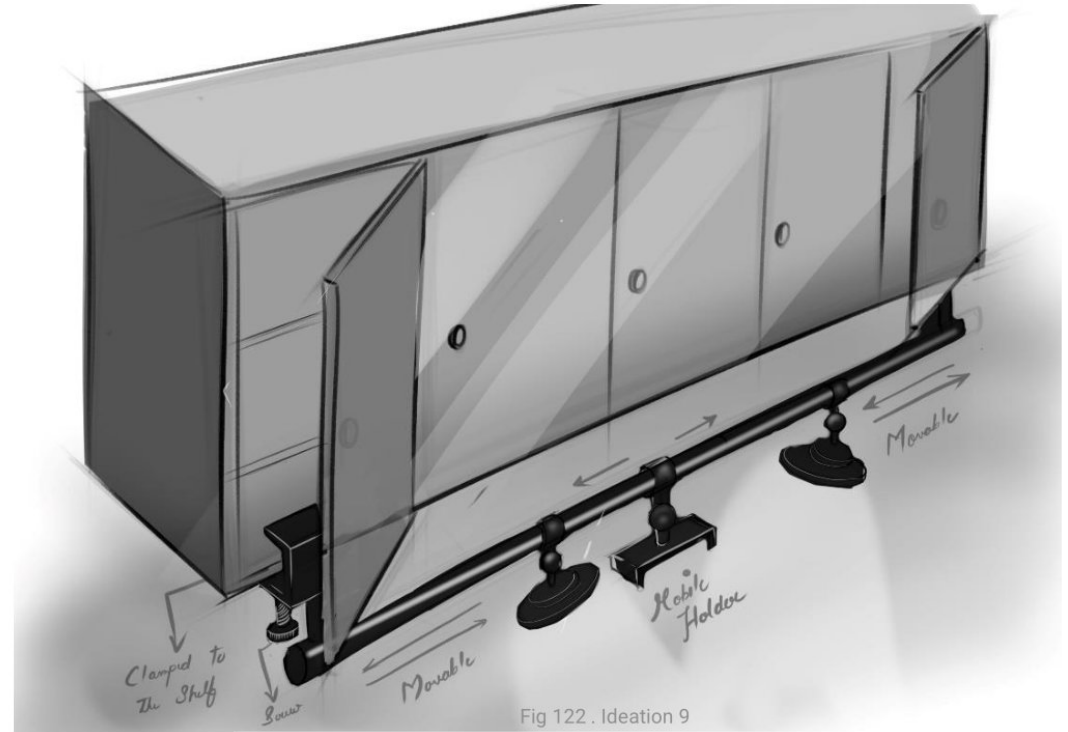

Fig 122 . Ideation 9

9.11 Ideation 10

Using string connectors

Here a string is controlled by 2 end connectors which will have a recoiling mechanism and they can be attached to wherever intended. There will be a tightening mechanism to hold them firmly. The camera can follow the path set by these connectors

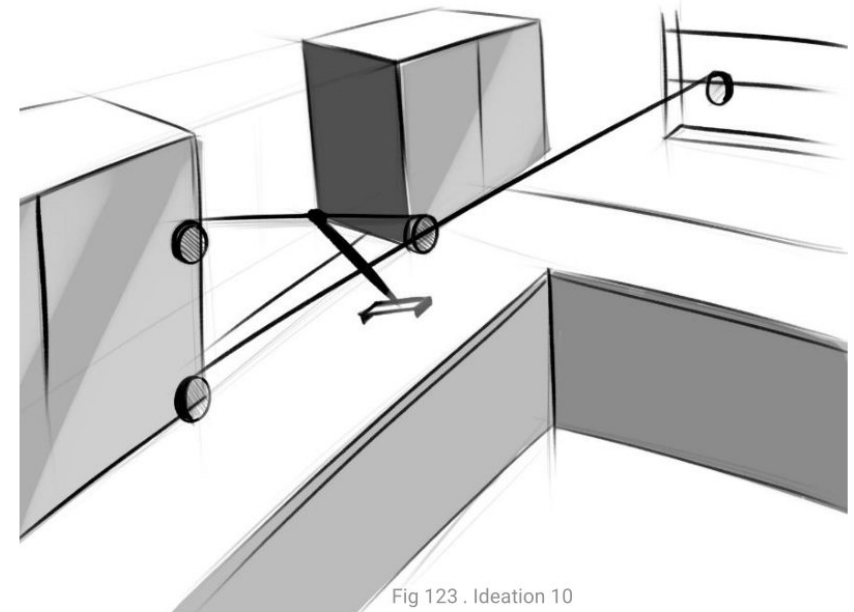
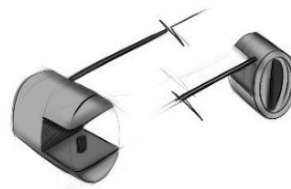

Fig 123 . Ideation 10

9.12 Ideation 11

Sliding fan Mechanism

While shooting from the top view the cooking fumes can come up and cover the camera lens. This makes the video blurry. The hot fumes can get condensed and stick to the lens making the video more unclear.

So in order to rectify this, this concept has a slid able fan running along the periphery of the camera lens. It should be movable as different phones have cameras on different portions.

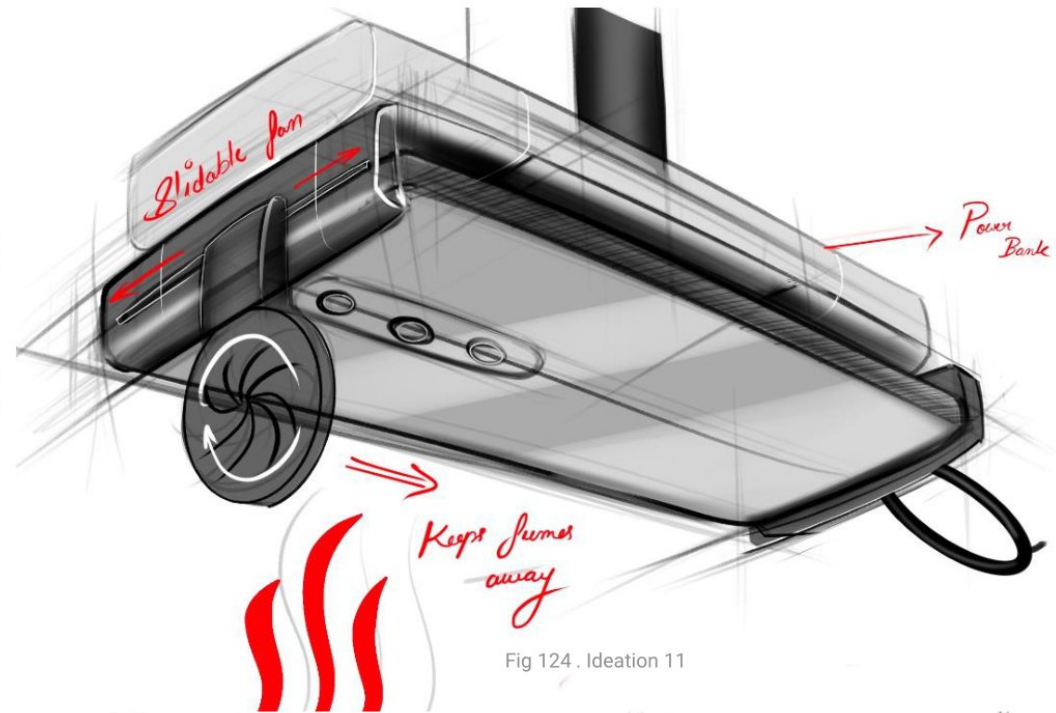

Fig 124 . Ideation 11

9.13 Ideation 12

Magnetic Holders

Here the holders are held in position using magnets attracting each other and they can be attached to both horizontal as well as vertical surfaces of the shelves given that they are available in the vicinity.

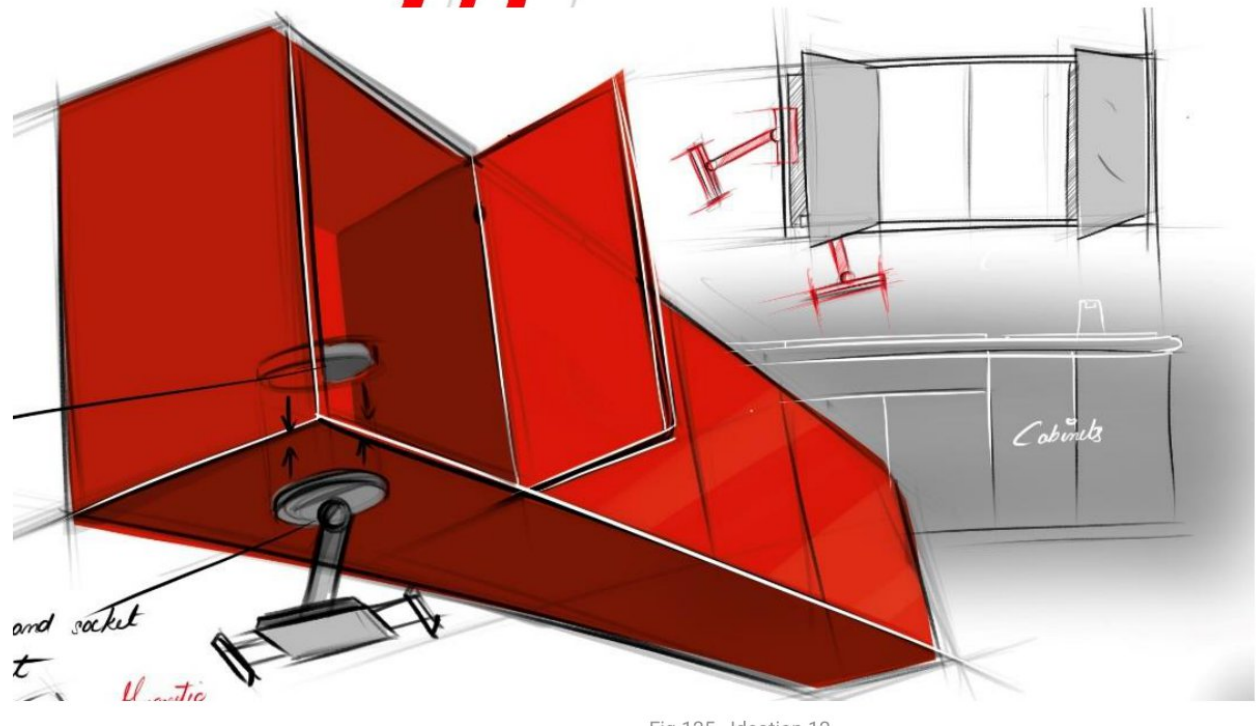
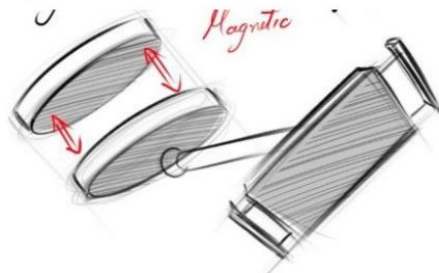
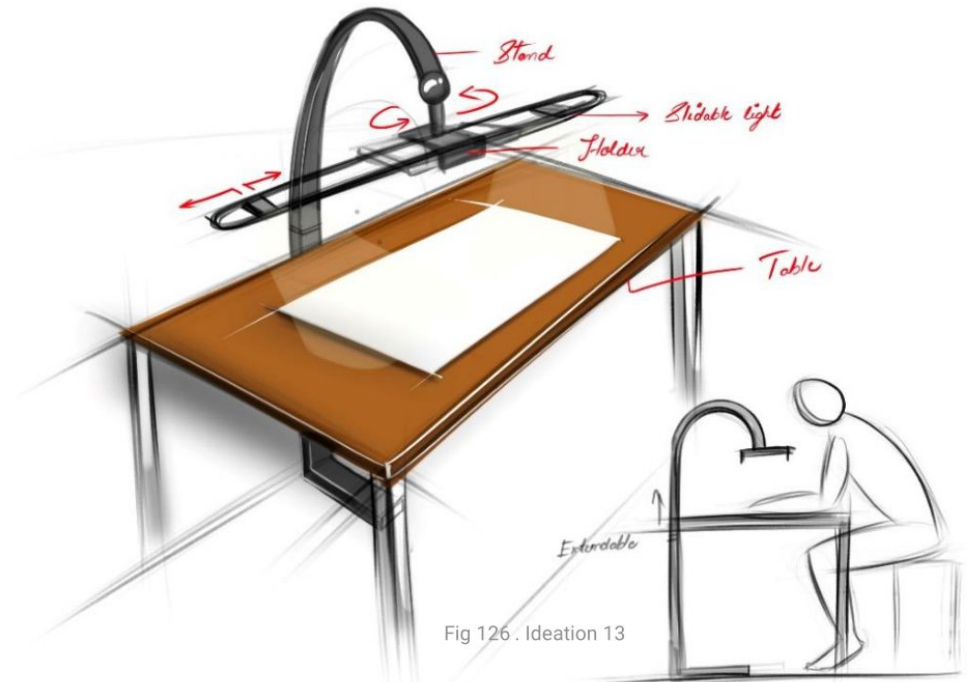

Fig 125 . Ideation 12

9.14 Ideation 13

Bending pipe Design

This concept aims at arts and craft vloggers where a steel tube coming from the bottom bends over on top of the artwork to get an Aerial view. It is rotatable to some extent and will have lights that slides to and fro and can be adjusted as per the user intends



9.15 Ideation 14

Sliding Rail Mechanism

Here horizontal and vertical railings are attached to the wall and the camera and lighting slides on a pipe that allows both vertical and horizontal movements.

The user can adjust the camera and lightings using a single hand itself. It will have cylindrical lightings which will slide on the tube and illuminate the scene.



9.16 Ideation 14.1

Rotating rail Mechanism

This is a slightly modified concept of the previous one. Here there are no separate railings for horizontal and vertical movements. Instead, they are replaced by a rotating rail which has a center pivot. It gets auto-adjusted in the required orientation when the user adjusts the position of the camera as required.

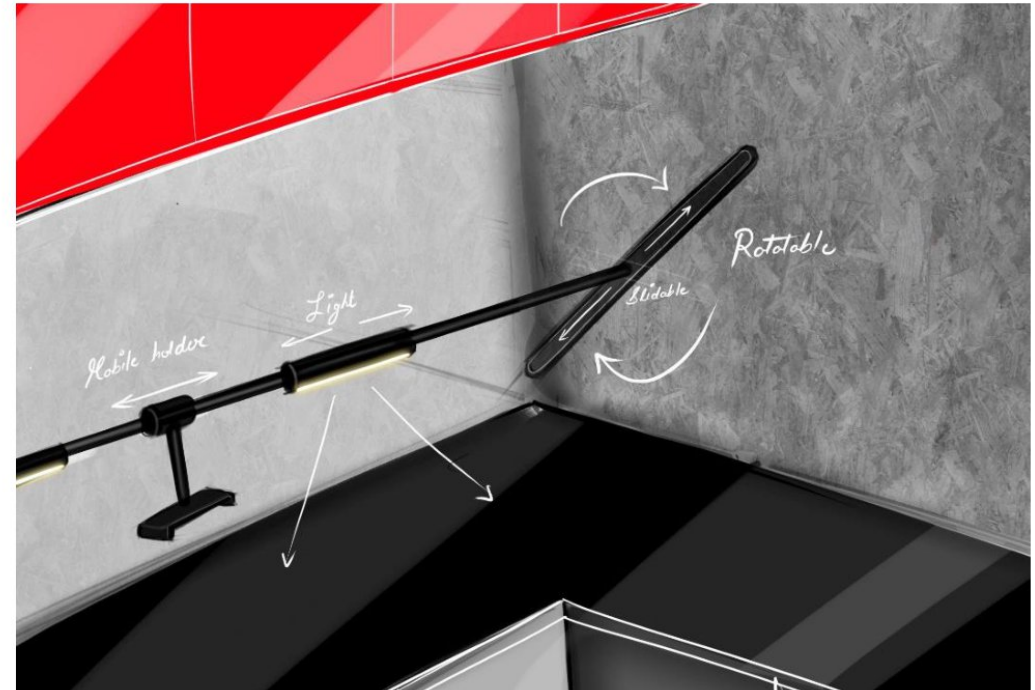

Fig 128 . Ideation 14.1

9.17 Ideation 15

Hanging Pipe Design

In this concept the entire set up is hung from the top using a string which is connected to a steel tube that is attached to both sides of the wall. The tube is collapsible from both sides which can be extended by rotating the center portion of the tube.

On rotation the 2 end of the tube extends outwards and touches the walls of the room. On further tightening the grip becomes firm and the device can rest on the walls without the string support and it becomes firm and steady. The user can now comfortably slide the camera and lightings over it and record the video

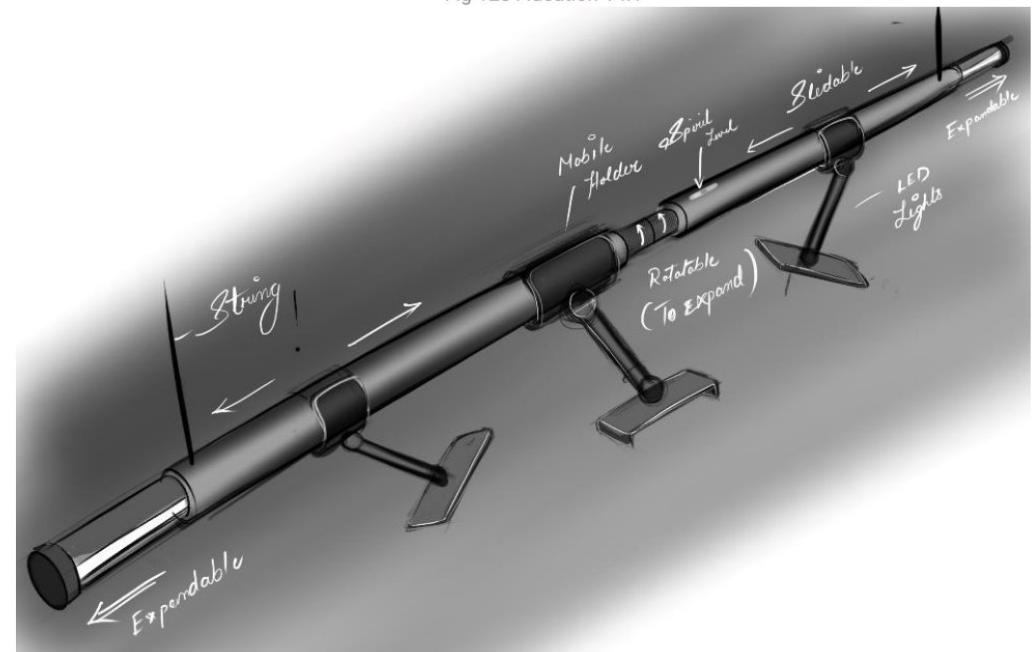
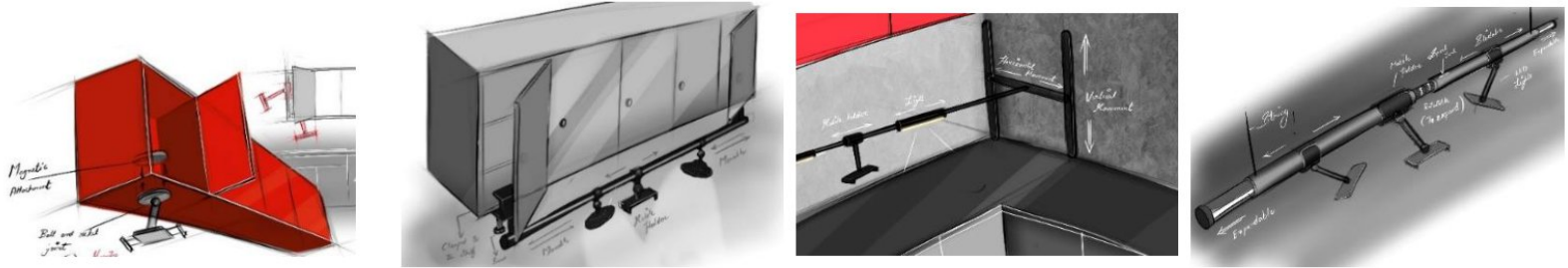

Fig 129 . Ideation 15

9.18 Concept Comparison

Out of the many ideations made, 4 of them were chosen and compared in order to find out the best one for making mock ups and carrying the design forward. Several factors considering the usability of the product were analyzed carefully.



Concepts	Magnetic Design	Shelf Clamping Design	Railing Mechanism Design	Hanging pipe Design
Type of Attachment	Temporary	Temporary	Permanent	Permanent
Method of Attachment when in use	Magnetic attachment	Clamping	Sliding	Compression
Suited for	Food Recipe Videos	Food Recipe Videos	Food Recipe Videos	Both
Storage when not required	Stored separately	Stored separately	Slid near to the wall	Goes up beneath the ceiling
Dependency while in use	Kitchen shelves	Kitchen shelves	Wall	Any Vertical necessarily strong support
Integrated lighting	No	Yes	Yes	Yes
Portability	Portable	Portable	Not Portable	Portable
Size	Small	Medium	Large	Large
Collapsibility	No	Telescopic joints	No	Telescopic joints
Secondary uses if any	No	Hanging light object if alternate fixing surface available	No	Ambient Lighting
Single hand operation	No	Yes	Yes	Yes

Upon comparison it was found that the **hanging pipe design** had the maximum benefits.

9.19 Concept Evaluation

After concept comparison the selected concepts were evaluated based on various factors and points were allotted out of 5

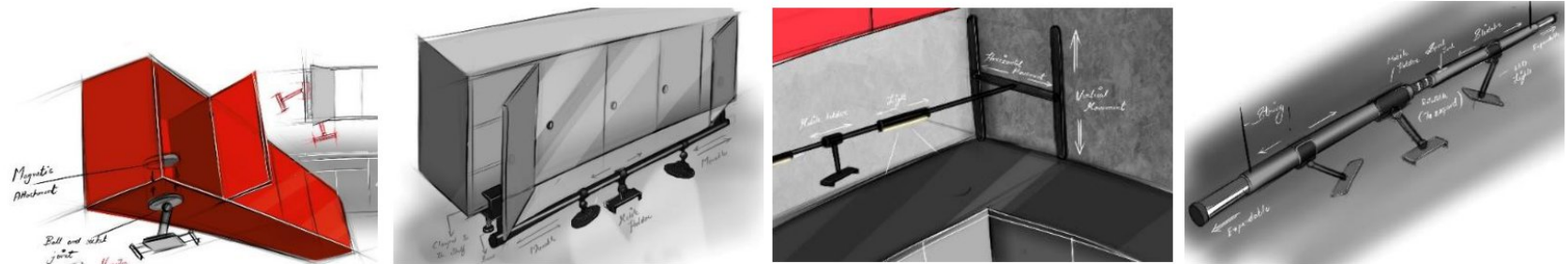

Concepts	Magnetic Design	Shelf Clamping Design	Railing Mechanism Design	Hanging pipe Design
Functionality	3	3	4	4
Compactness	4	3	1	2
Collapsibility	1	2	1	3
User friendliness	3	3	4	4
Storage	4	2	1	3
Time efficiency	2	3	5	4
Portability	4	3	1	2
Safety	2	3	4	3
Independency	1	1	1	3
Effortless camera position Shifting	1	3	4	4
Value addition	1	2	1	4
Secondary use	1	2	2	3
Total	27	30	29	38

After the evaluation it was found that the was that the **Hanging pipe Design** scored the maximum.

9.20 Concept Development

The chosen concept was taken forward and more detailed sketches regarding the fitting and usability aspects of the product were done.

The hanging pipe design would be designed in such a way that it would rest at the top as an ambient lighting when its not in use. It can be pulled down in same manner as pulling down a blinder and then after it comes down it can be attached to the walls by rotating at the center



Fig 130 . Hanging pipe concept

As it comes down in a collapsible form and extends outwards it wont disturb the neighboring shelves.

Method of attachment

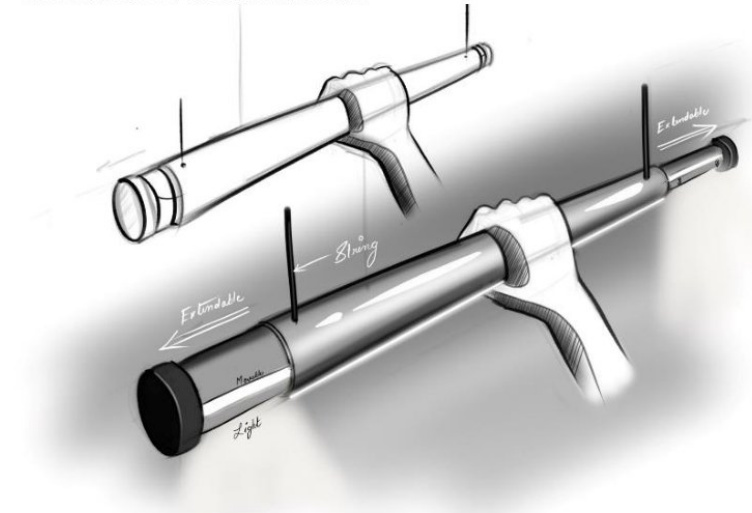

Fig 131 . Hand on device

The extendable portions press against the wall upon rotation in the center and makes the device firm using compression.



Fig 132 . Tightening mechanism

This works in the manner as fitting a pull up bar designed to be fitted at the doorway. It becomes strong enough to withstand the weight coming on it.

The user working in the kitchen can simple pull down the string to bring the device down.



Fig 133 . Usability 1



Fig 134 . Usability 2

As it comes down in a collapsible form and extends outwards it wont disturb the neighboring shelves. This concept was initially designed to be hung from the ceiling. But it was later changed to a support attached to the walls. And this support holds the device. This change was made because it was difficult to attach anything on the ceiling compared to the walls and people would prefer that more.

A blinder mechanism ensures that the device is coming down in a levelled manner and is parallel to the kitchen top.

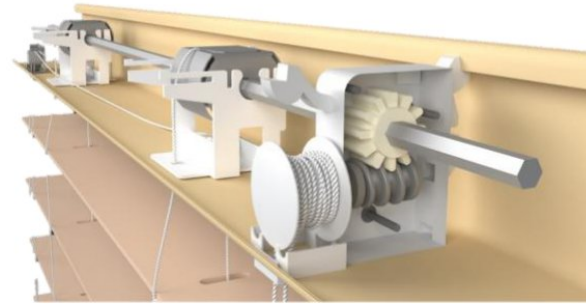

Fig 135 . Mechanism

The device could be even detached and moved to a separate wall if necessary and depending on the kitchen layout. There would be spirit levels on the device to ensure correct levels.

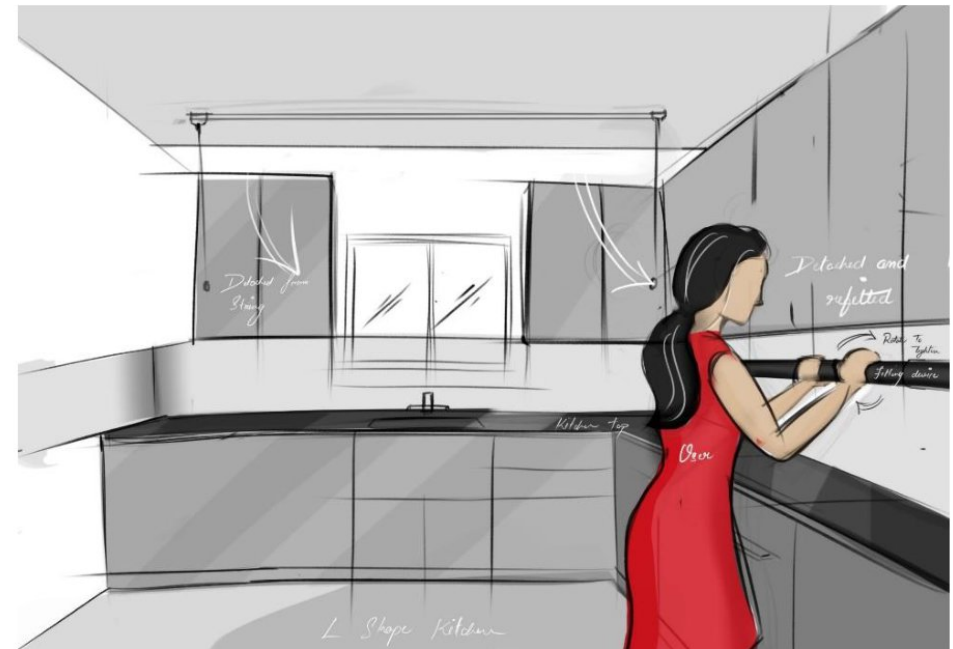
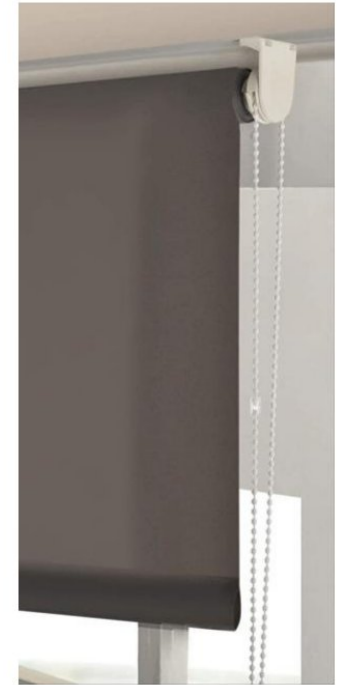

Fig 136 . Usability 3

This design can be used by an artist as well by attaching the device on the intended area above the table and lowering it when required. As it has a strip light below the tube external lighting may not be necessary in some cases.



Fig 137 . Artist using design

9.21 Concept Detailing and additional features

Method of attachment

The supporting tube can be made of Aluminum and will have an inserting mechanism as shown

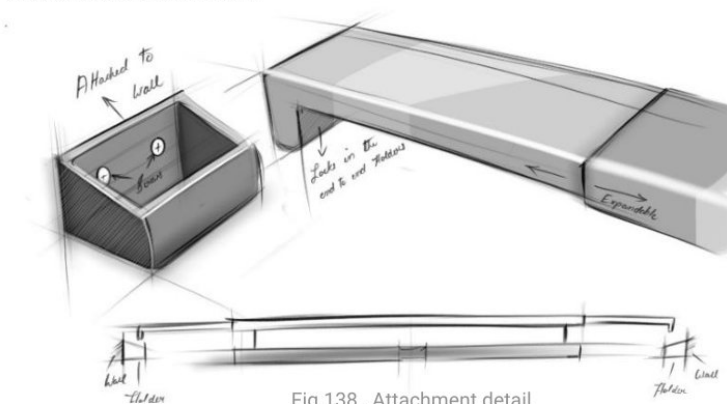

Fig 138 . Attachment detail

Rotatable and sliding lights

The movable lightings would be such that they remain on top off the main tube and it will be Invisible when looked up from the bottom . They can be rotated and brought down as when required by the user



Fig 139 . Lighting detail

Magnetic attachment and Mirror Concept

In order to decrease the complexities the attachments would be fully magnetic so that the user can easily attach the mobile phones . It will also decrease the number of steps compared to a typical screwing mechanism. A mirror will also be attached to the device so that the user can see a reflection of what is being recorded from an angle which is about the eye level.

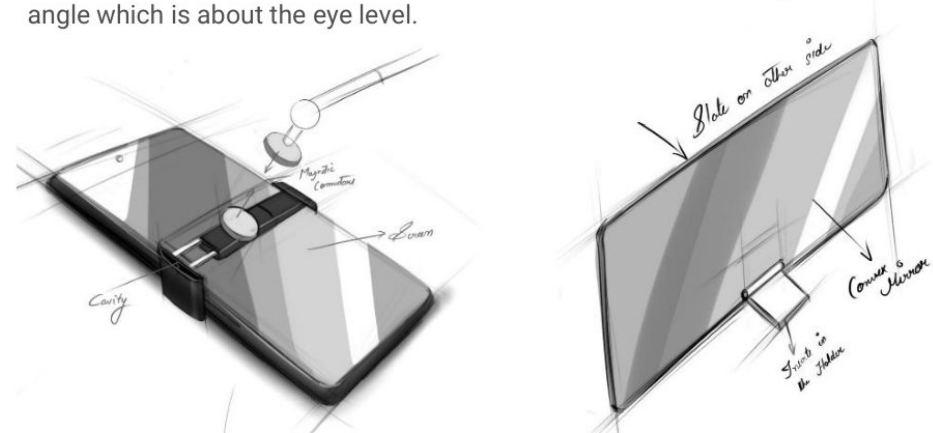

Fig 140 . Mirror function

Erasable slate at the back

The back of the mirror is an erasable slate in which the user can write the main keywords and refer to it while recording the video. It will be placed in such a way that it is not very obvious that the user is referring a note.

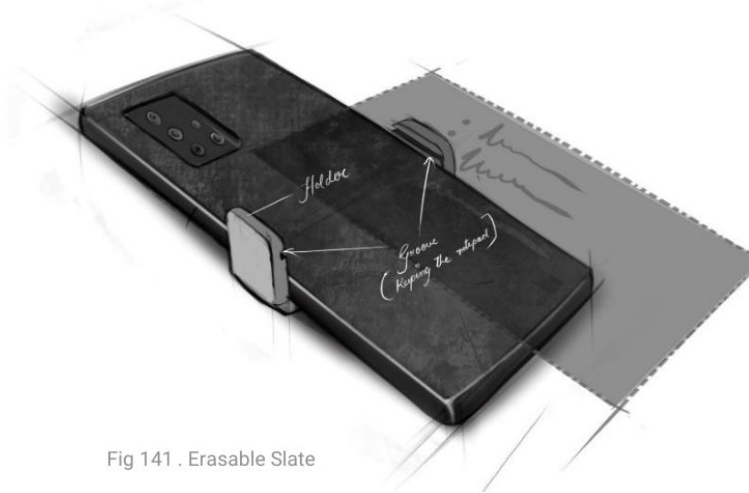

Fig 141 . Erasable Slate

Fan to keep the fumes away

A fan would be attached to the whole setup so that the cooking fumes can be blown away by the fan and it does not interfere or blur the video.



Fig 142 . Fan mechanism

Holder Mechanism

The mobile holder holds the mobile from the back using a magnetic attachment and can orient in any manner as required by the user

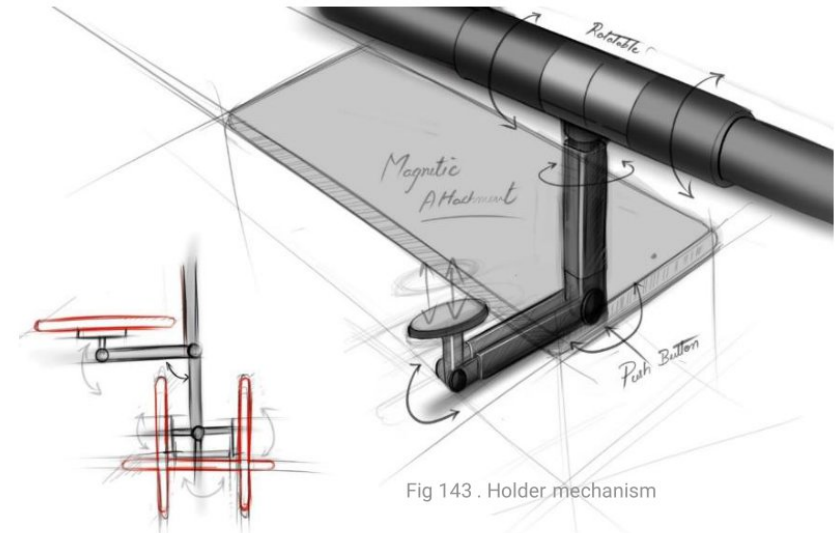

Fig 143 . Holder mechanism

It can also be a gooseneck mechanism in order to make it more flexible

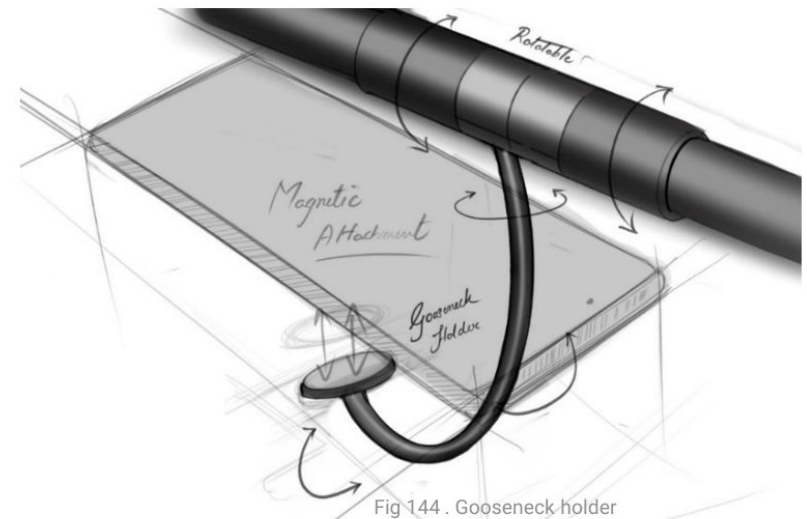

Fig 144 . Gooseneck holder

10. Mock up – Hanging pipe Design

Materials used



Pipes – PVC and Metal

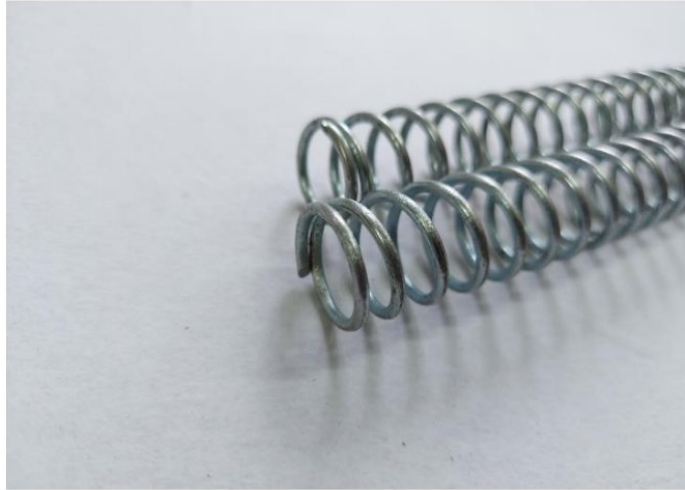

Springs



Rubber Stoppers



Ball and Socket Joint

IDC - IIT Bombay



Tightening rings



Magnets

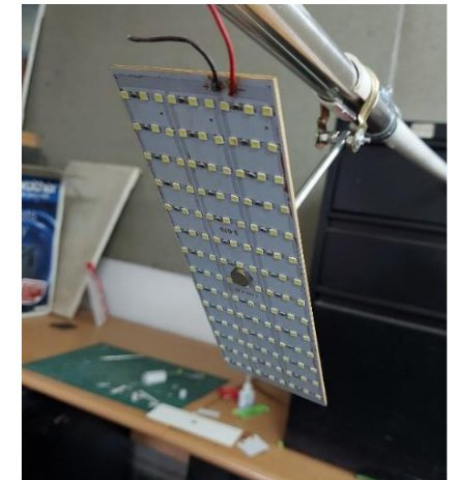

LED lights

Fig 145 . Mock up materials

A mock up was made using steel and plastic pipes and was hung from the top using a support . It could hold also hold onto to the walls when it is elongated as in the design. The compressive force was achieved using springs . The other detailing are shown below. The phone attachment was by attaching a magnet to mobile holder which had a ball and socket joint in order to facilitate every angle.

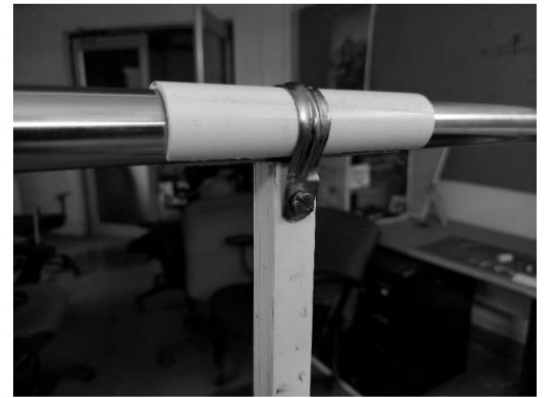
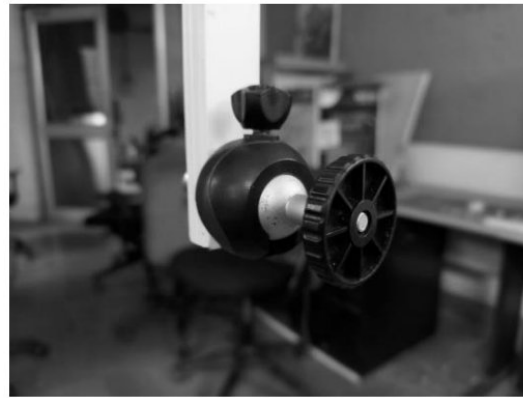
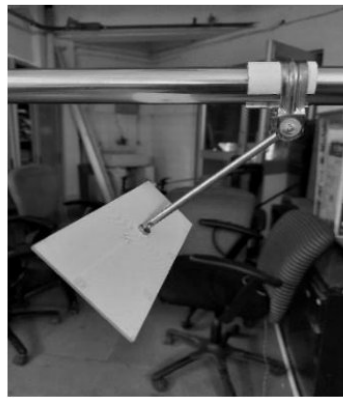
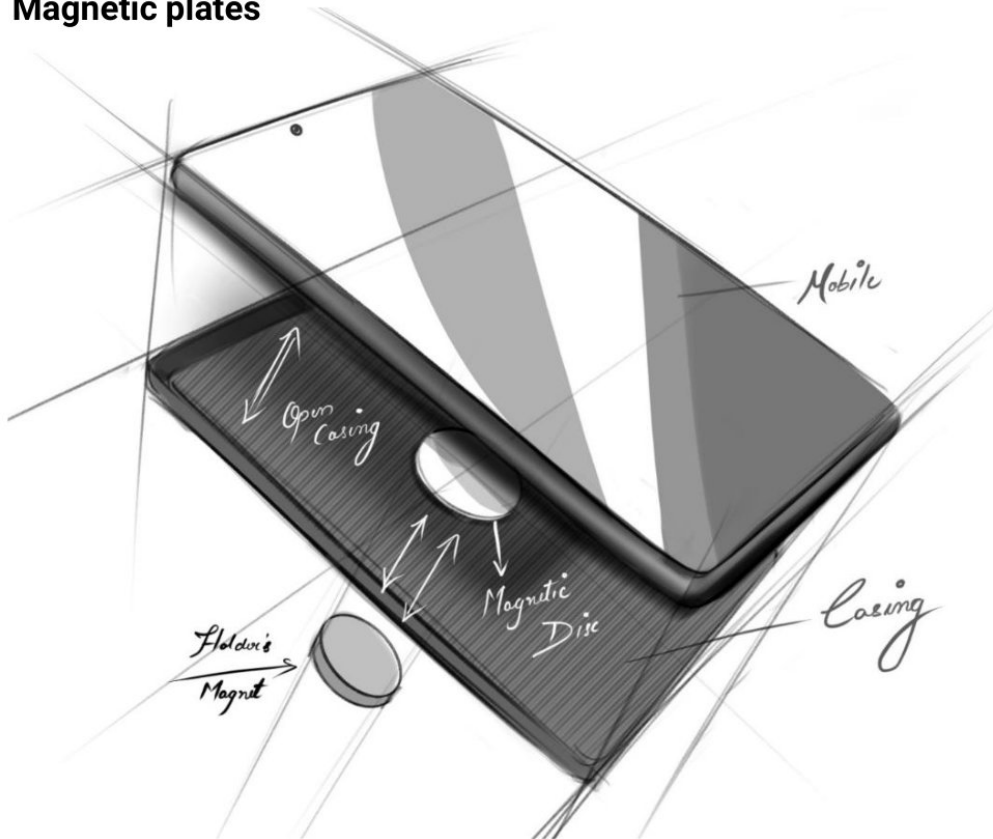

Fig 146 . Mock up detailing

Magnetic plates



Magnetic attachments are easily possible for mobile phones having magnetic charging feature like iPhone. For phones without this feature a magnetic disk can be placed inside the phone case and this case can easily stick to a magnetic holder along with the phone. The magnet is powerful enough to hold the mobile in position and also maintain the orientation in which they are placed.



Fig 147. Magnetic disc mechanism

Room Dimensions

In order to find out the suitability of the product the dimensions of kitchens and sketching rooms of 20 users were collected

SI No:	Kitchen Type	Dimensions[in m]
1	Single walled	3.1 x 2.6 m
2	Single walled	2.9 x 2.5 m
3	Single walled	3.2 X 2.6 m
4	Single walled	3 X 2 m
5	Single walled	3.3 X 2.8 m
6	Single walled	3 x 2.2 m
7	Single walled	3.2 x 2.3 m
8	L shaped	3 x 3.6 m
9	L shaped	2.9 x 2.8 m
10	L shaped	3.3 x 2.9 m
11	L shaped	3 x 2.1 m
12	L shaped	2.9 x 2.9 m
13	L shaped	3 x 2.7 m
14	L shaped	3 x 3 m
15	Gallery kitchen	3.2 x 2.8 m
16	U shaped	3.2 x 3 m
17	U shaped	3.4 x 3.1 m
18	U shaped	3.1 x 2.9 m
19	Island kitchen	3.6 x 3.1 m
20	Island kitchen	3.5 x 3 m

SI No:	Dimensions [in m]
1	3 x 2.9 m
2	3.2 x 3 m
3	2.2 x 2
4	2.8 x 3.2 m
5	2 x 2.6 m
6	3.1 x 2.5 m
7	2.9 x 2.6 m
8	3.1 x 3 m
9	3 x 2.6 m
10	3.2 x 2.8 m
11	3 x 2.6 m
12	3 x 3.8 m
13	2.8 x 3.1 m
14	3.1 x 2.8
15	3 x 2.9
16	3.6 x 2.8 m
17	3 x 2.9 m
18	3.1 x 2.7 m
19	3.2 x 2.7 m
20	3 x 2.9 m

Based on the data , it was found that some kitchens were large and coming close to 3.6 m in length. Some of the users used bedrooms itself for sketching and art works which was also coming close to lengths of 3.6m length.

10.1 Mock Up Testing



Fig 148 . Mock up testing

The mock up was tested to verify its workability and find out any difficulties

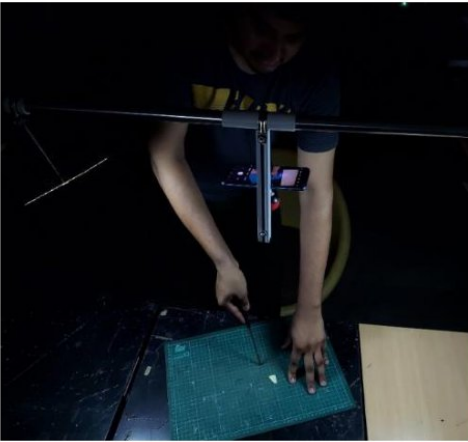

Insights

The design was flexible and the mobile and lightings could be moved over the rod very conveniently according to the requirements of the user. User could record from top view very effectively

The design could also be shifted to a different orientation making it suitable for kitchens of various layouts.

However this design had some **limitations**.

Dimensional constraints – The design is very much suitable for kitchens and rooms having small dimensions but won't be suitable for larger rooms as the pipe length may fall short and may not reach both the ends, making the product dysfunctional.

Packaging difficulties – The long length of the pipes would make it difficult for packaging and transportation

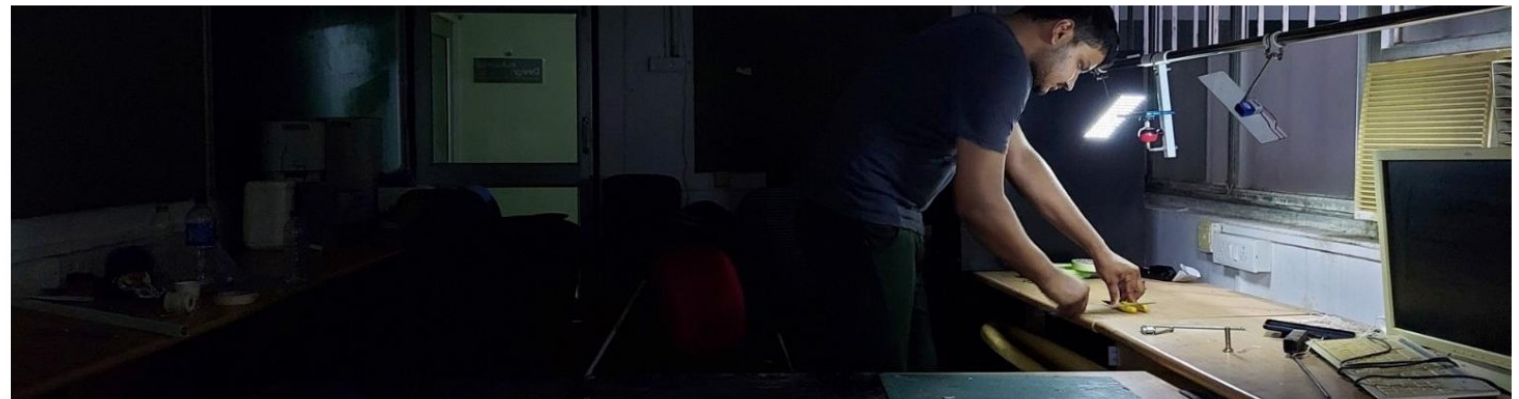

Fig 149 . Mock up insights

Eventually this design had to be **discarded** due to these factors.

11. Final Concept

Recording on a string

In this concept camera is made to run on string using a 3 wheel mechanism. The center wheel is attached to the motor and the 2 others are freely rotating type. In this way the camera can be made to move in the forward and backward directions. This design is inspired from the big professional camera set up used in filming high velocity actions scenes. Thus a customized compact version can be made for mobile phones.



Fig 150 . Cable cam



Fig 152 . Cable cam size comparison

Working Mechanism

The device moves forward due to the friction created by the string.

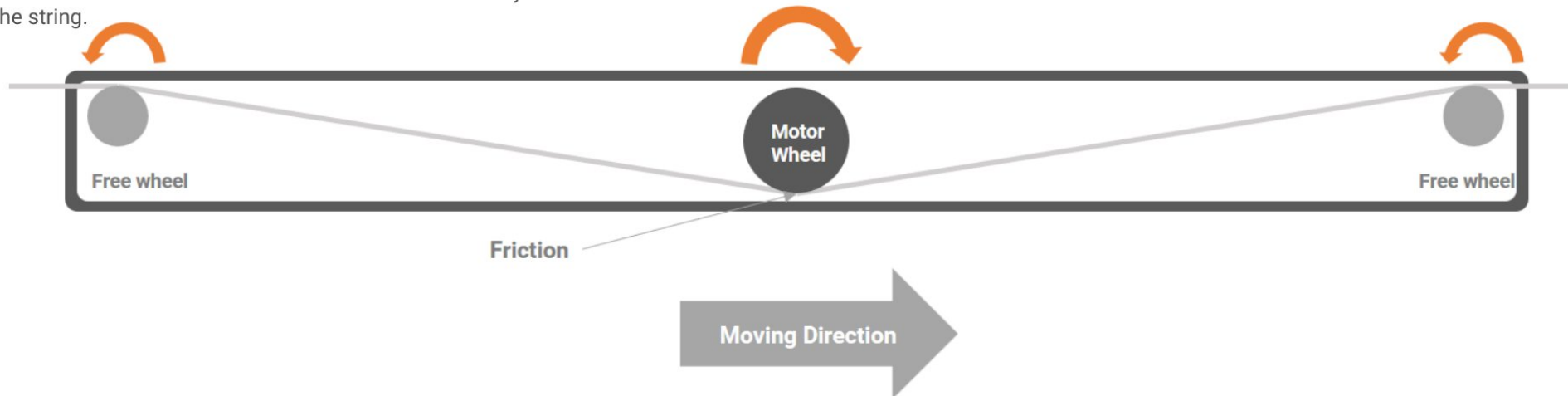

For this mechanism to work there should be a level difference between the central motor wheel and the free wheel so that the thread remains in tension

Different ideations were tried keeping intact the wheel alignment

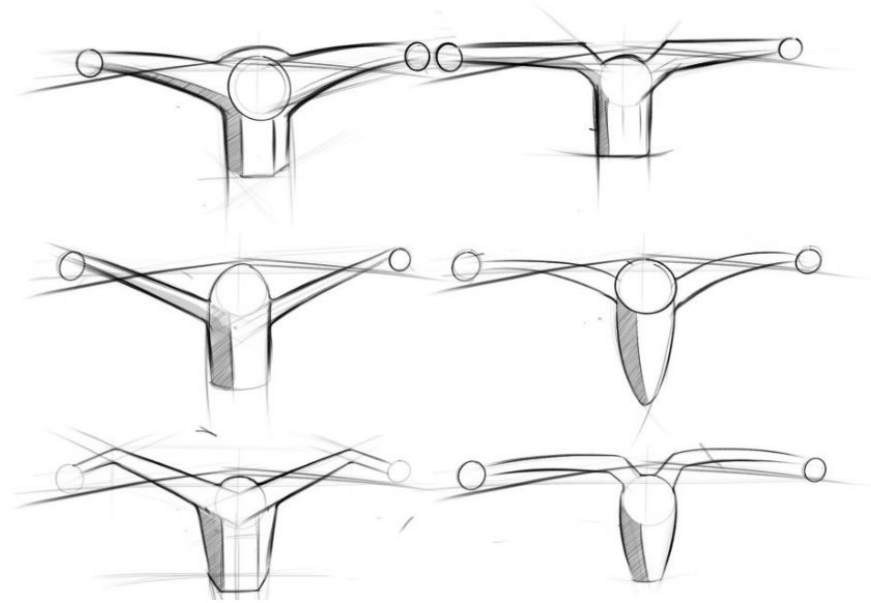

Fig 153 . Wire cam ideations

11.1 Concept 1

Groove Cut Design

In this concept an an angle groove is given for the thread to be put into it so that the thread gets aligned by itself thus decreasing the number of steps for user and making it more convenient.

The thread can be aligned in any manner by using hooks so that it covers the whole room

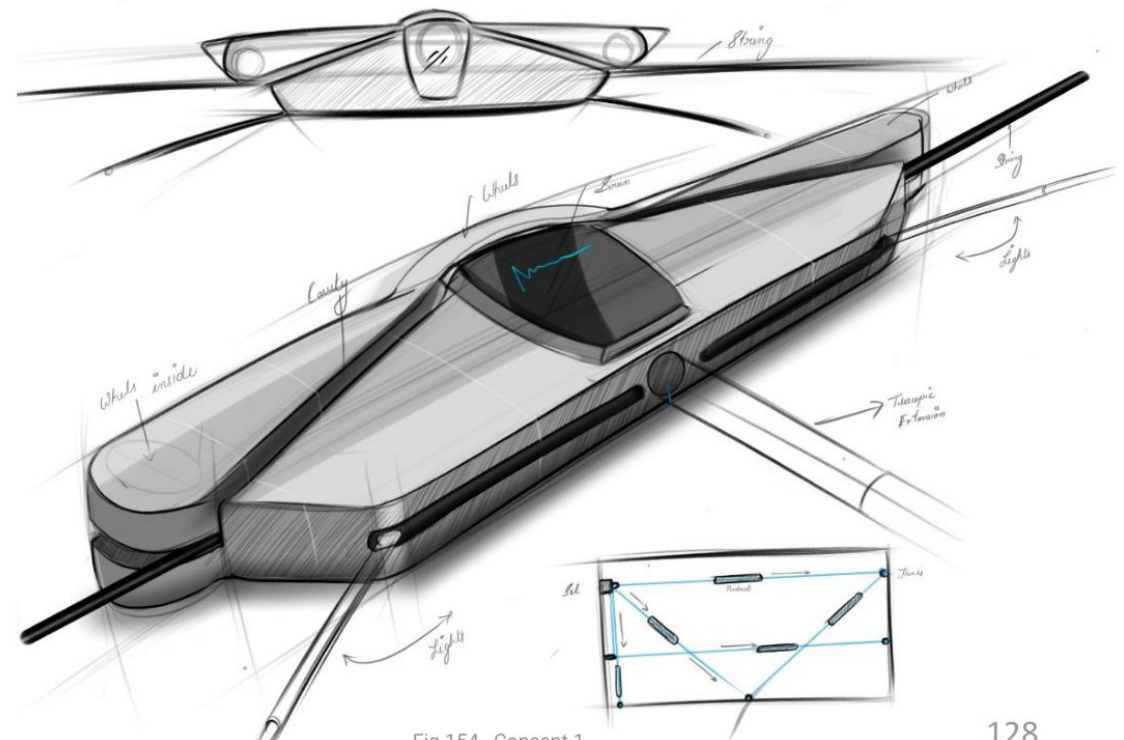

Fig 154 . Concept 1

11.2 Concept 2

Straight grooved Push-up Design

This is a modification of the earlier concept. Here the groove is straight instead of an tilted one. The user has to simply slide in the thread into the groove minimising the number of steps and making it easier and comfortable for the user. The user now has to push up the central wheel so that it comes in an alignment to bring about the friction.

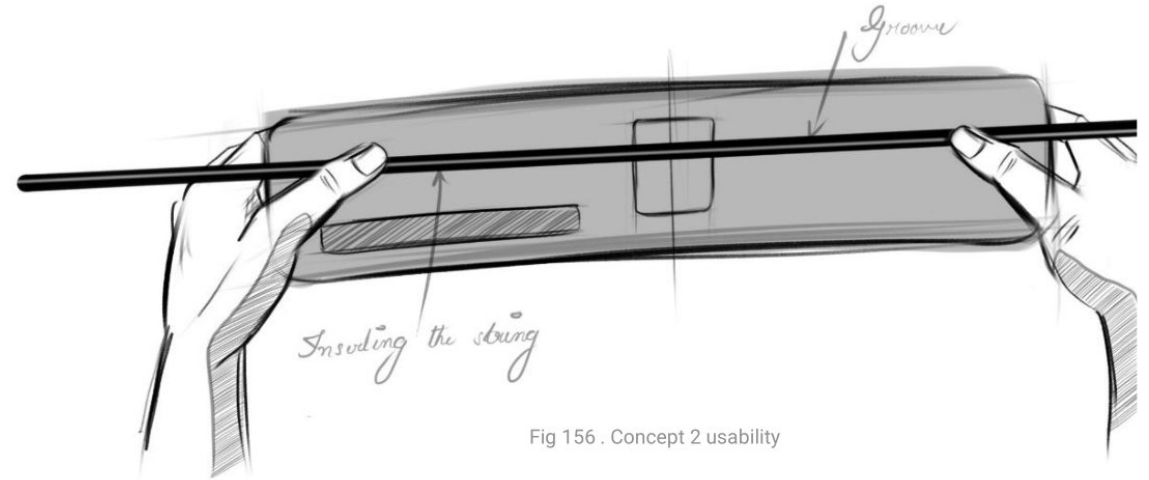

Fig 156 . Concept 2 usability

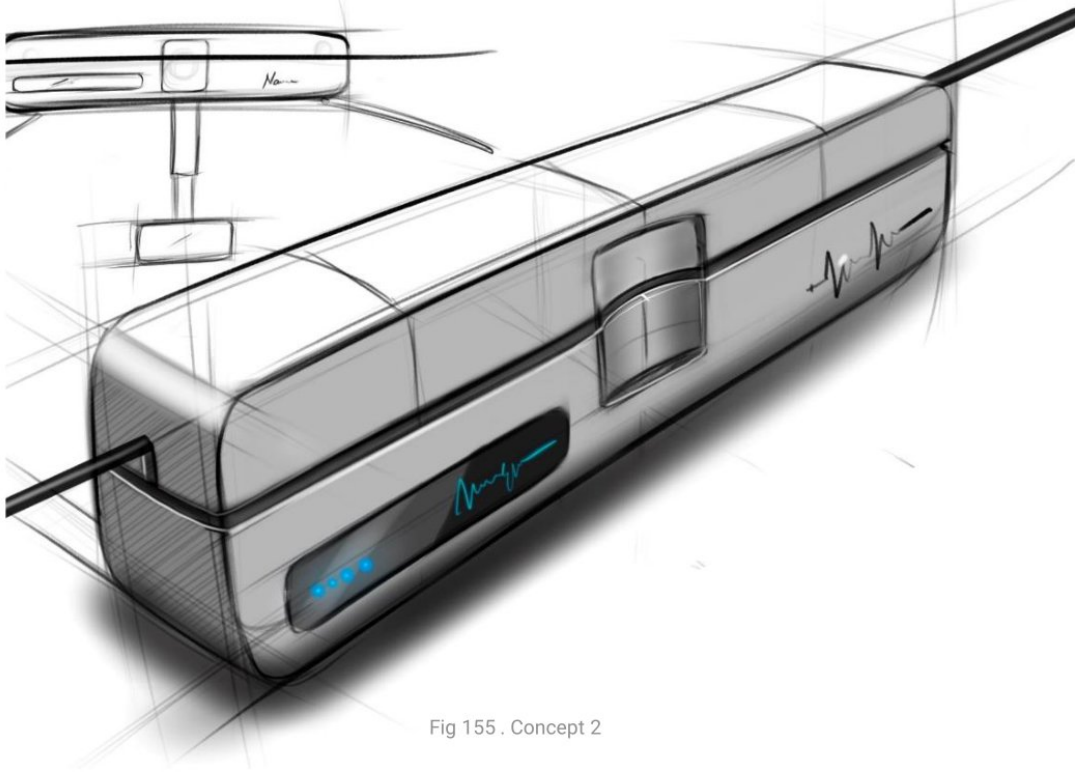

Fig 155 . Concept 2

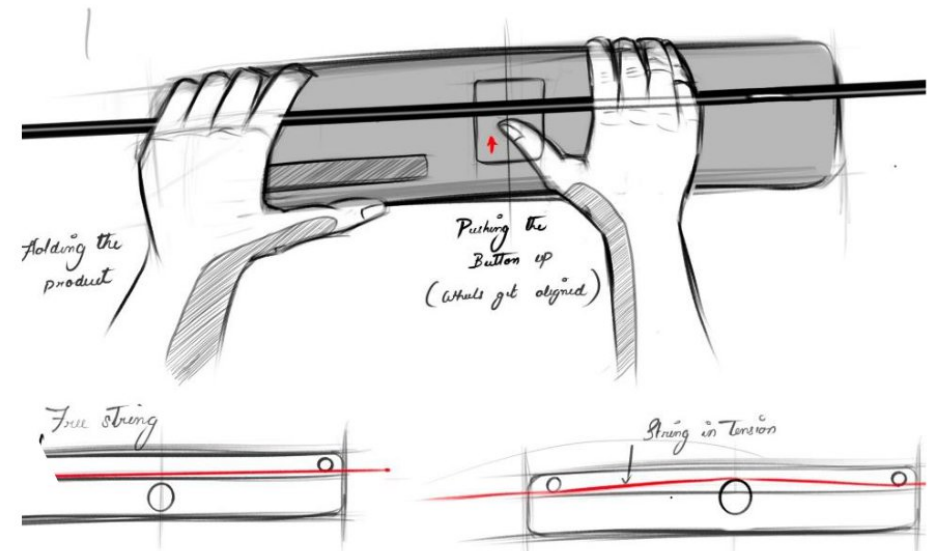

Fig 157 . Concept 2 steps

11.3 Concept 3

Straight grooved Push-down Design

This is an attempt to modify the earlier concept and reduce the number of steps so that it becomes further easy for the user .

This design reduces one more step in the earlier design. Now the user can simply push down the freewheel soon after the device is slid in the thread. The user doesn't have to change his grip to do this step

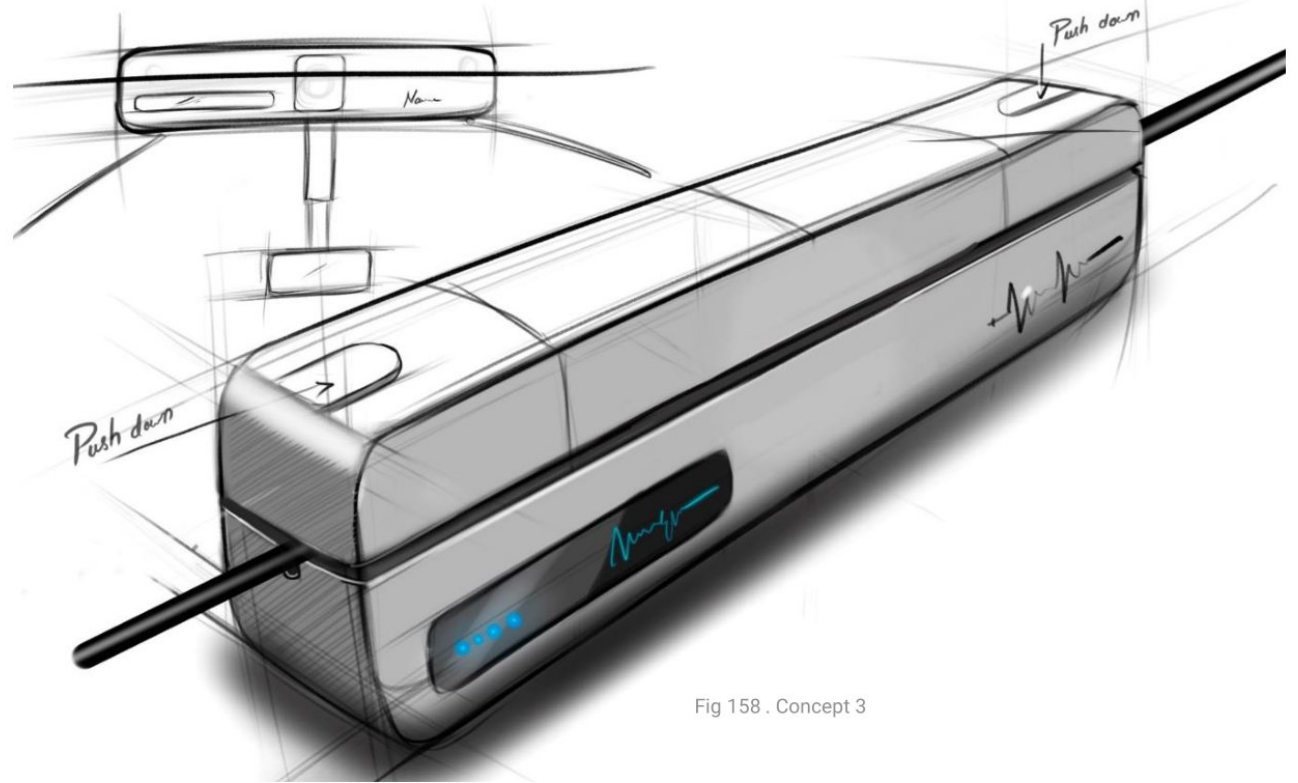

Fig 158 . Concept 3

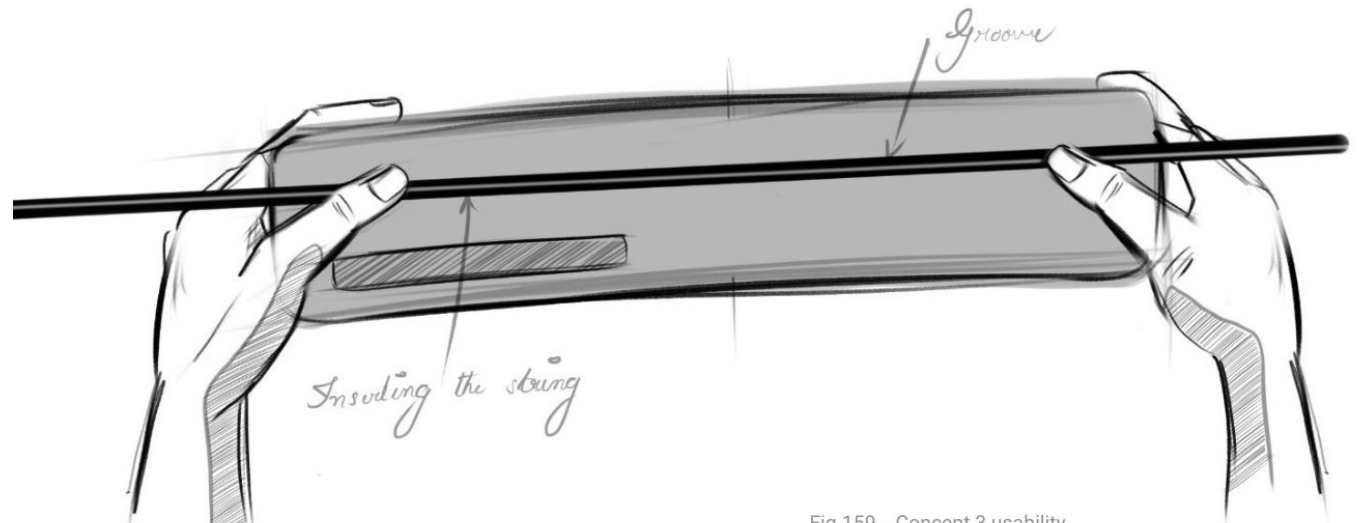

Fig 159 . Concept 3 usability

11.4 Concept 4

Minimal Aluminum Tube Design

This concept is a very minimalistic approach to the 3 wheel mechanism design. Here the whole assembly is concealed in an aluminium tube and the design is very simple. The user doesn't have to slide in the device to make a proper alignment. All the mechanisms are already in built and the user doesn't have to worry about it anymore. The aluminium tubes gives the design very sleek look making it more minimal.

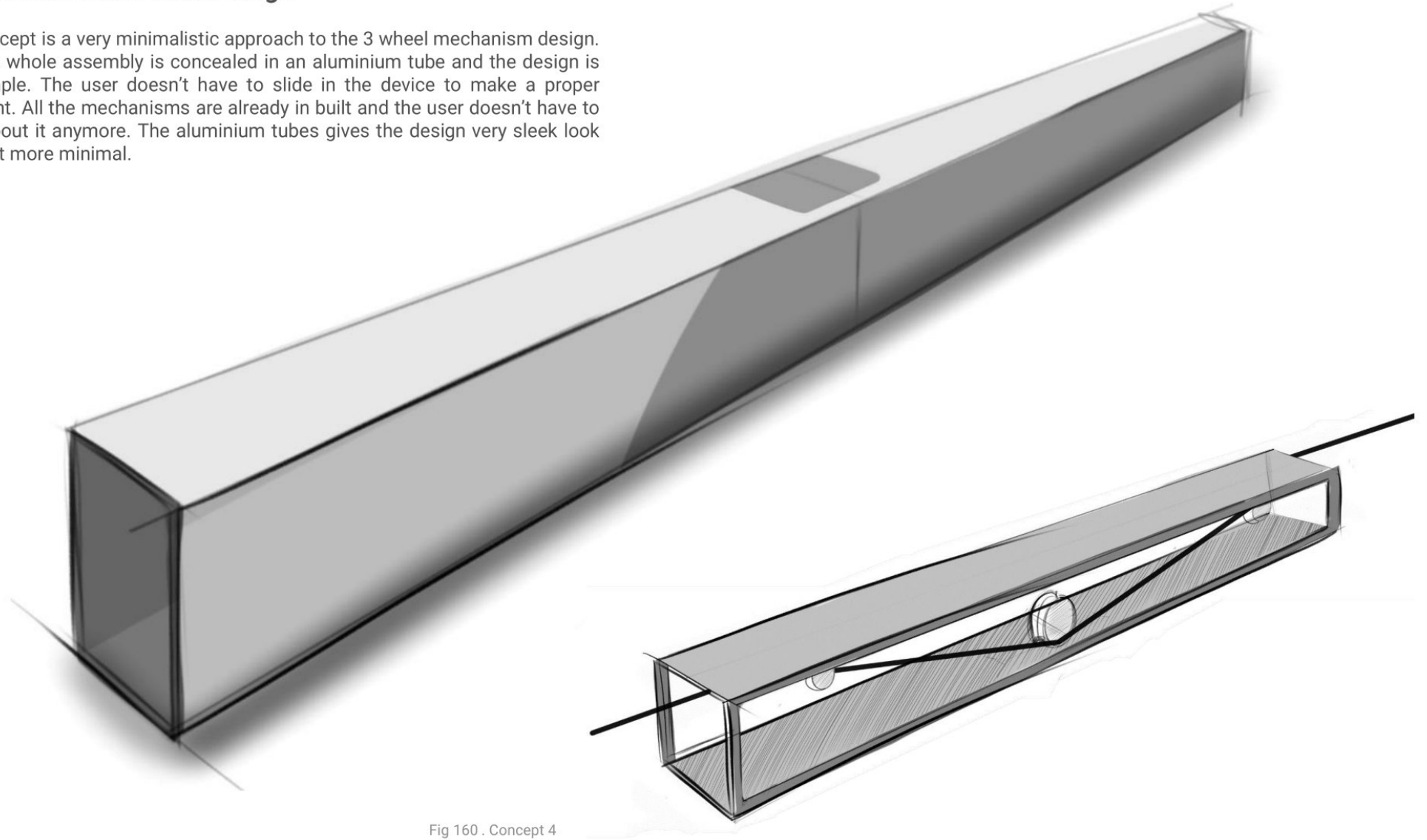

Fig 160 . Concept 4

12. Mock up – Minimal AI Tube Design

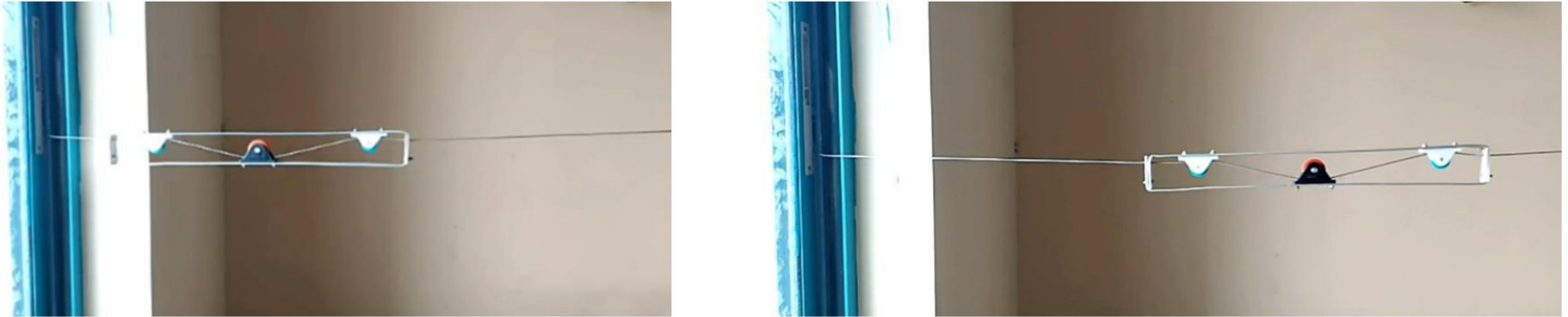

Fig 161 . Mock up testing

A mock-up was made to test the 3 wheel mechanism and it was working perfectly fine . It could move smoothly on a string.

12.1 End Capping

The aluminium tube will have plastic enclosures which would have the USB charging port, power button etc.

The recoiling mechanism is designed such that it can be detached along with the product and can be stored separately.

The wall attachment would be screwed and it will have a simple slide in mechanism.

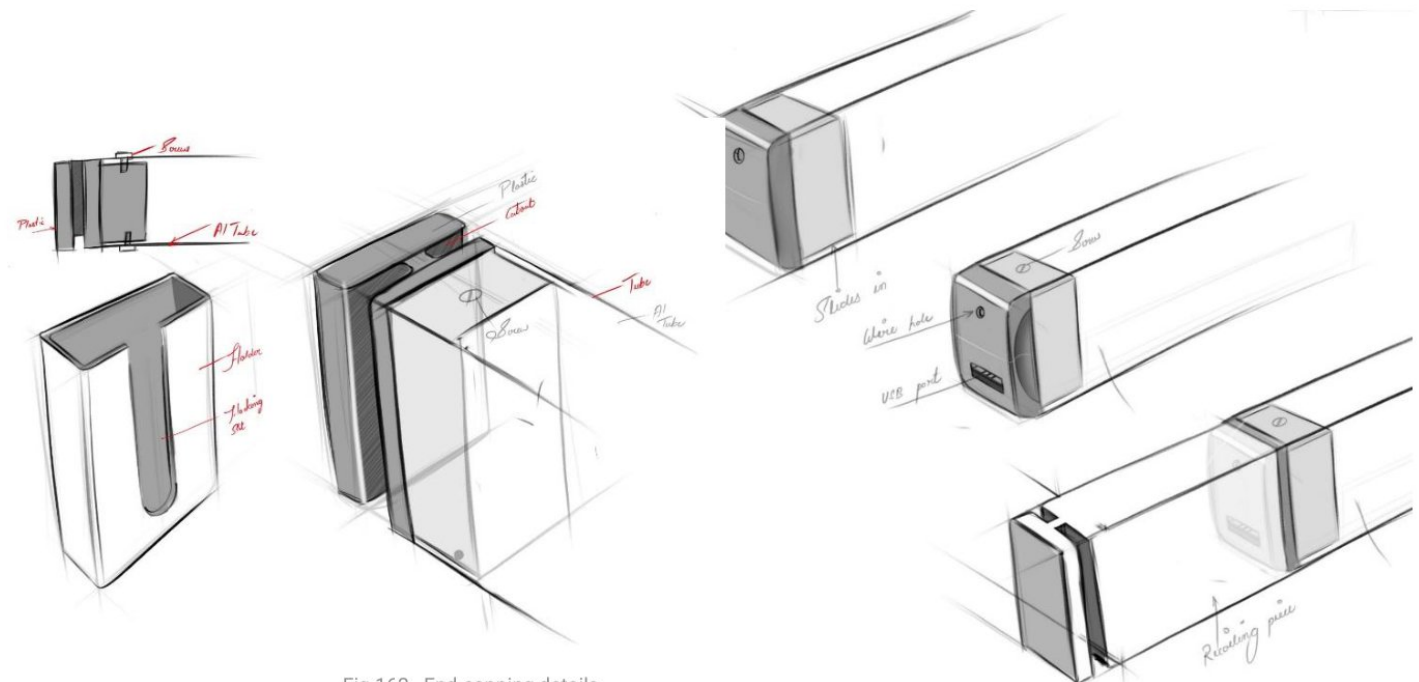
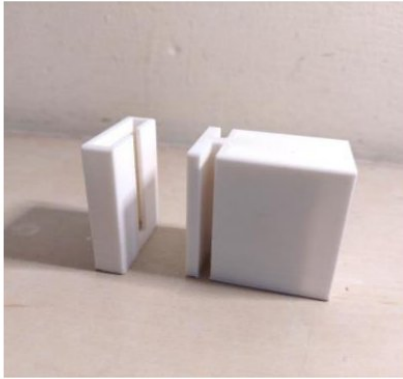

Fig 162 . End capping details

A number of enclosure designs with 3D printed and tested out to choose the most suitable one. The wall attachment detail and recoiling mechanism interlocking unit were also 3D printed and checked to verify it worked well .



12.2 Interlocking Mechanism



Fig 164 . Interlocking

The product has a very minimal interlocking mechanism on the wall. The user simply has to slide in the recoiling part to the wall attachment part. The device then becomes freely slidable on the string. It has the same interlocking mechanism only opposite wall as well.

Insight

Upon testing the mock up it was found that the recoiling force alone will not be able to withstand the weight coming on the string once all the attachments are made. So in addition there is a tightening mechanism using an Allen key setup which is embedded within the design itself.

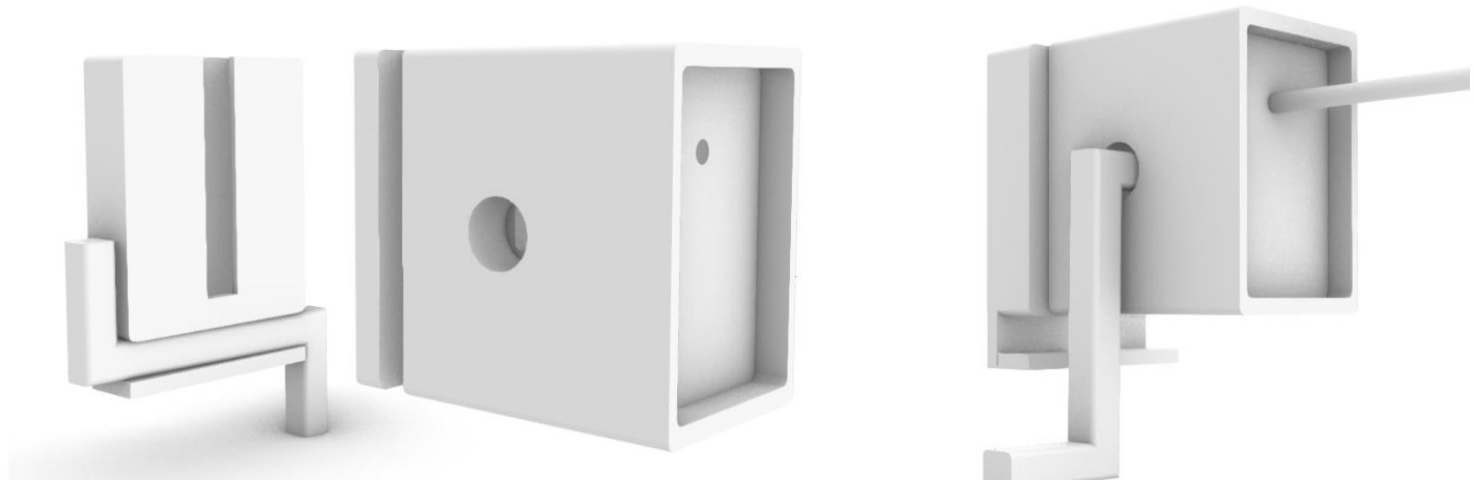

Fig 165. Allen key idea

12.3 Mobile Holder Design

The most important factor while designing the mobile holder was the **center of gravity** of the system . It goes at most necessary that all the weight should be coming exactly below the moving part to maintain the correct orientation of the device. The other factors to be considered were -

- Mobile Holder attachment to the moving part
- Phone and holder interaction
- Facilitate all orientations of mobile (Portrait , Landscape , tilted angles)
- Communicating with the user about way of attachment

After some ideations it was found that at C shaped holder with an embedded magnet could be suitable for this function . It was important than all the orientations of the mobile phone should be taking place exactly below the moving part so that the centre of gravity of the system is maintained and the device is stable.

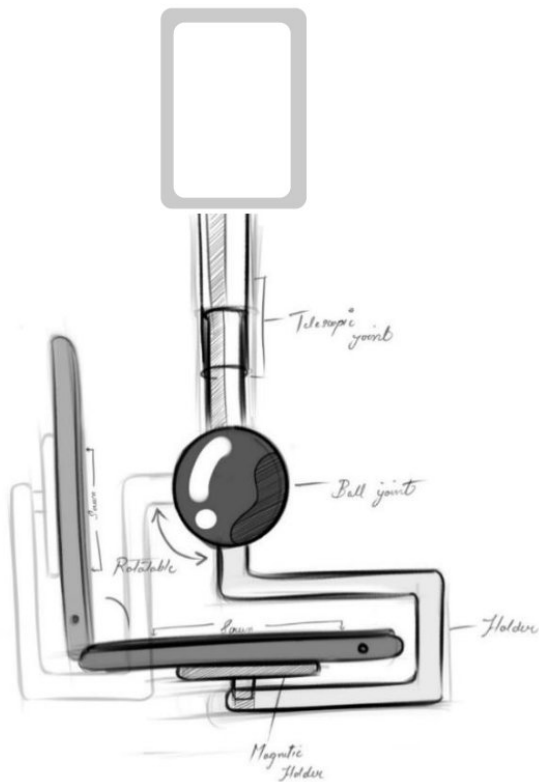

Fig 166 . Mobile holder

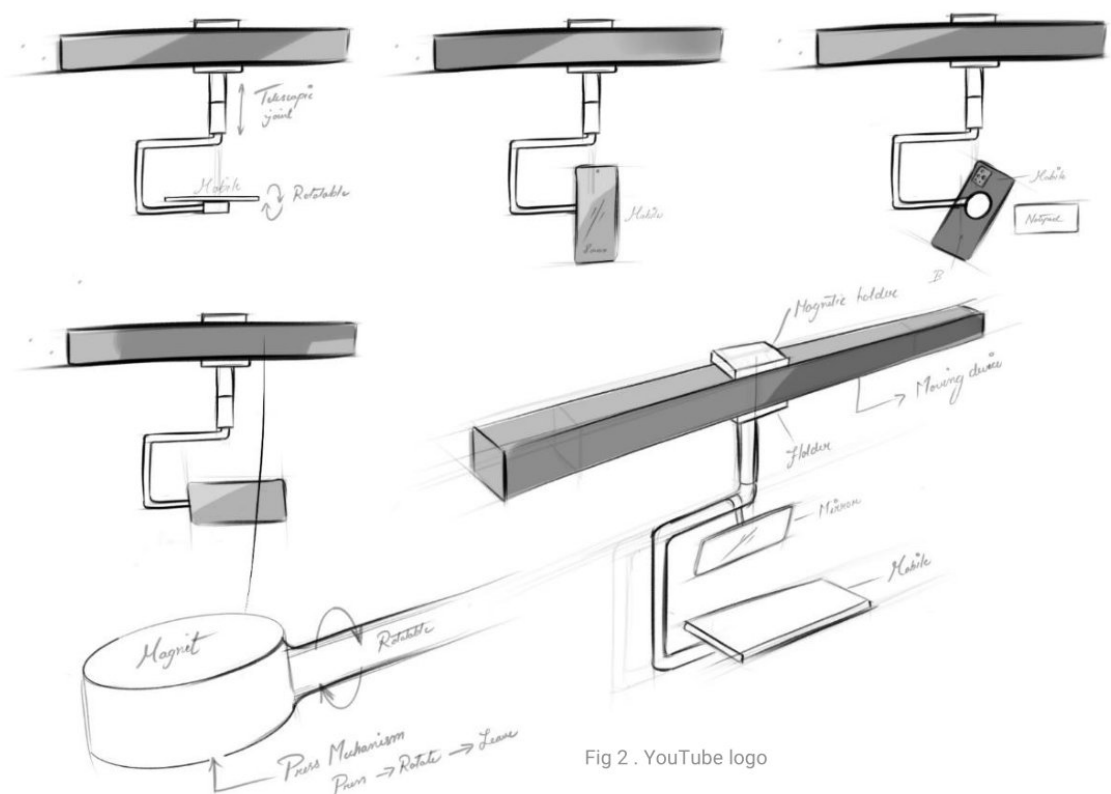

Fig 167 . Holder iterations

Fig 2 . YouTube logo

12.4 Circular cutout Detail

This cut-out detail was given at the back so that the user can easily find the way of attachment of the device . It will also have a tiny magnetic connector to hold the clamp as well as give electric supply to the detachable part

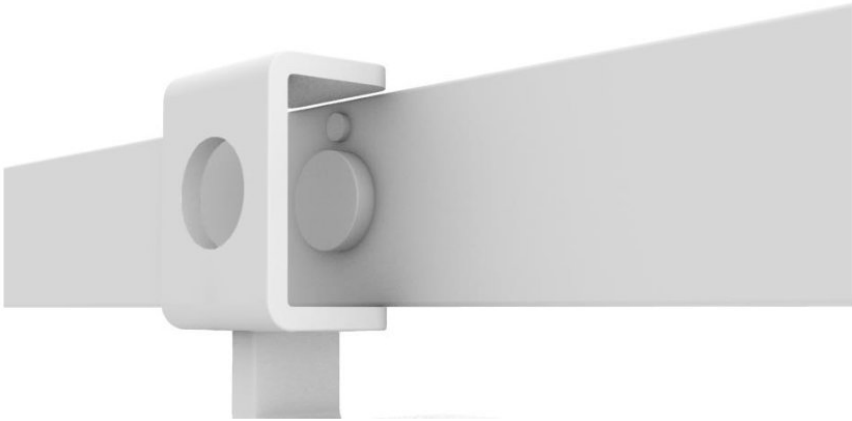

Fig 168 . Circular cut out

Different iterations of holder design were tried it out to find the most aesthetic one.

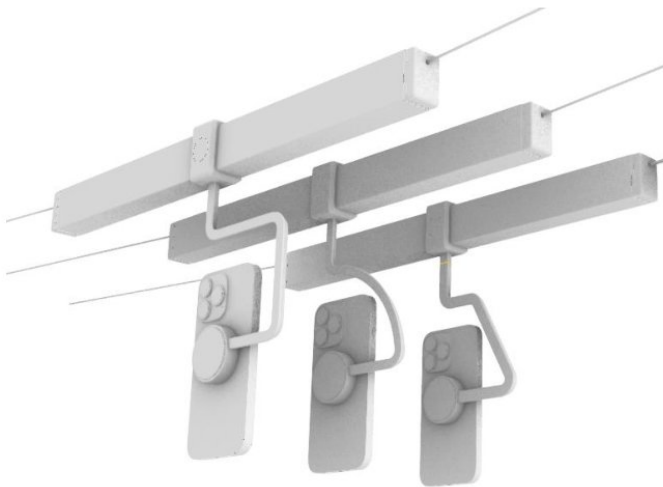

Fig 169 . Mobile holder ideations

12.5 Holder Mock ups

Mock-ups were also made to test the aesthetics of the design and the last design was selected

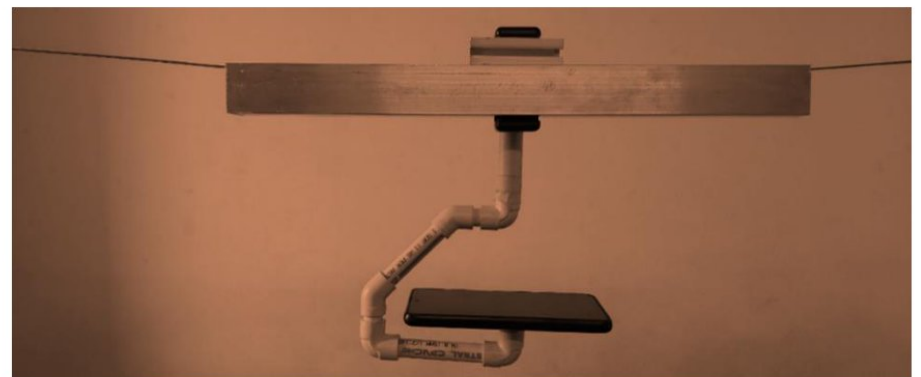
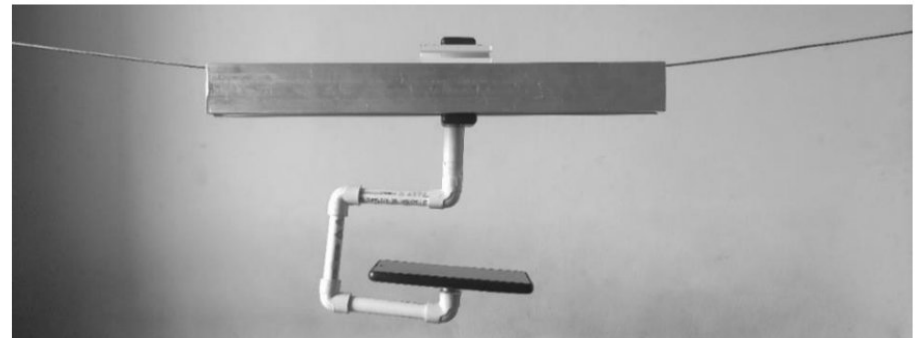
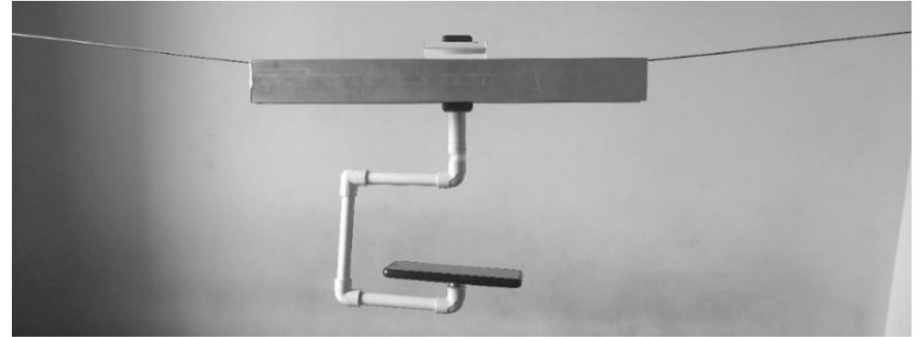

Fig 170. Holder mock ups

12.6 Aluminum Tubes

For deciding the dimensions of the moving part , aluminium tubes of different dimensions were tested by attaching with the mock-ups and the most aesthetic one was chosen.

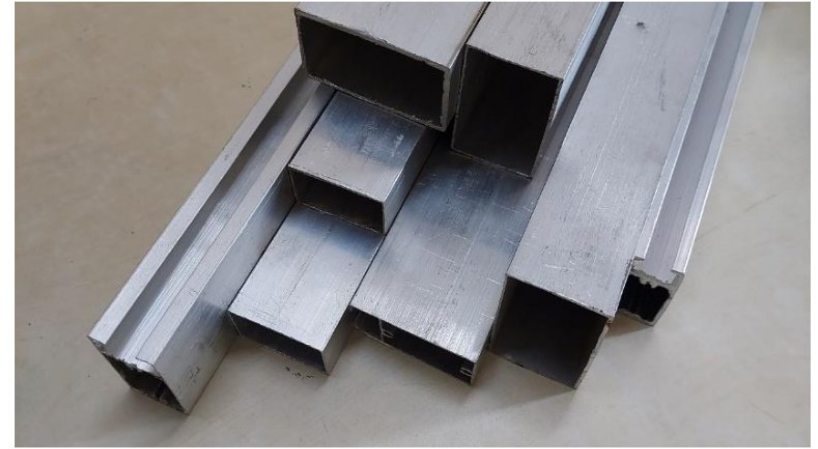

Fig 171 . Al tubes

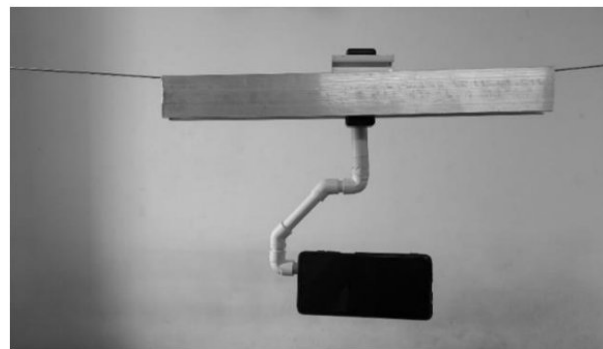
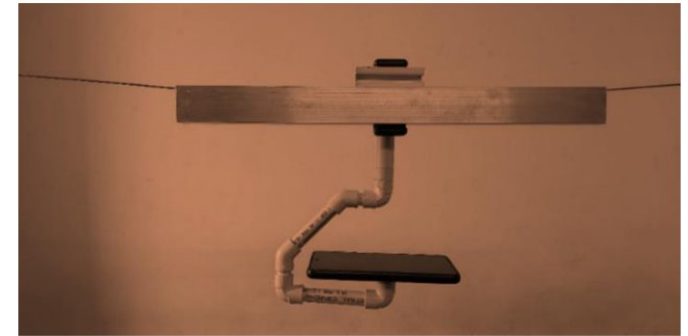
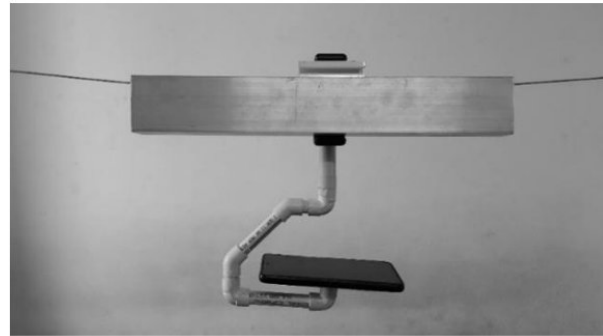
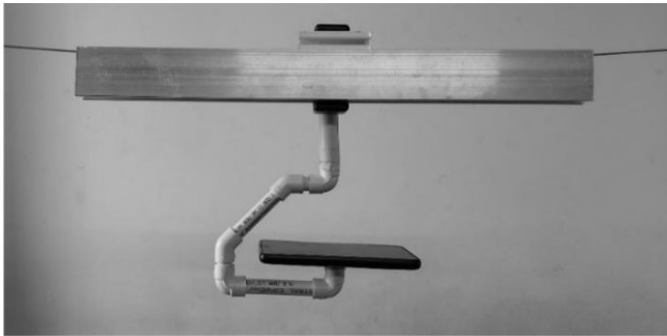

Fig 172 . Al tubes dimensions

Here the 3rd one having a length of 45 centimetre was chosen for the final product

12.7 Magnetic Attachment

Magnets were used to attach the mobile phones onto the device. A small magnetic disk was kept inside the case and mobile attached to the device. The magnets holds the mobile steady and also maintains the orientation in which it is kept. A magnet having a diameter of 4- 5 cm would be a best option.



Fig 173 . Magnetic connection

12.8 Different orientations using magnetic attachment

The figures show the different varieties of orientation setups possible using this holder design and using magnetic holders. The holder is designed in such a way that, in whichever form it gets aligned, the center of gravity is maintained and the mobile rotations happen exactly at the bottom of the moving part and doesn't alter the stability of the device.

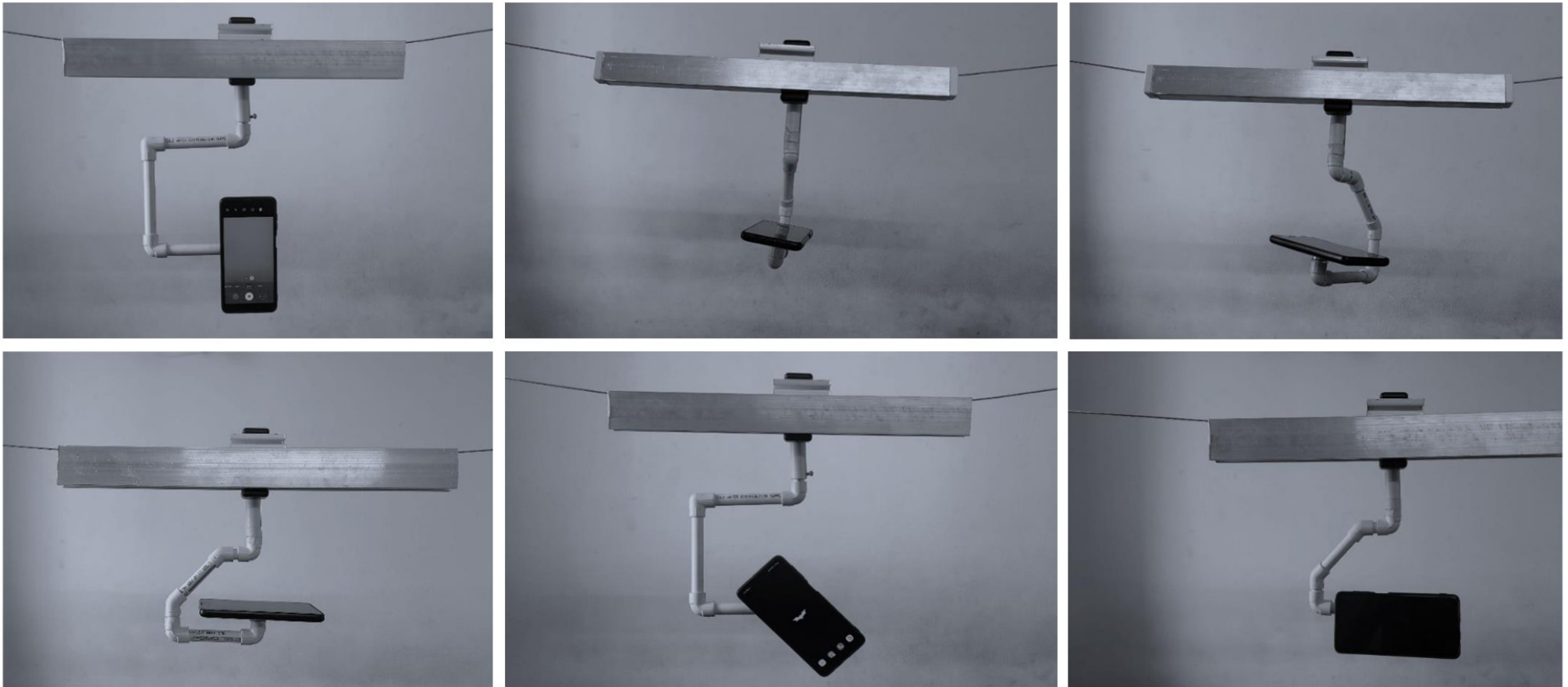

Fig 174 . Different mobile phone orientations

12.9 **Cooking fumes** interference

As mentioned earlier in the report when cooking videos are shoot from top view there is a chance at the cooking films can get accumulated on the camera lens resulting in a blurry video.



Fig 175 . Kitchen fumes

12.10 **Mock up – Fumes Testing**

This was tested using joss sticks as a mock up



Fig 176 . Fumes mock up

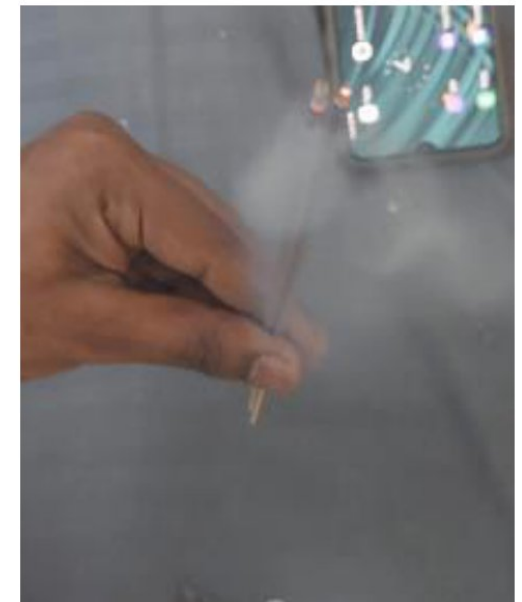

Fig 177 . Blurry video

It was verified that the fume coming onto the camera lens results in a blurry video the video.

12.11 Testing Proposed Solutions – Blower concept

12.11.1 Using a USB fan

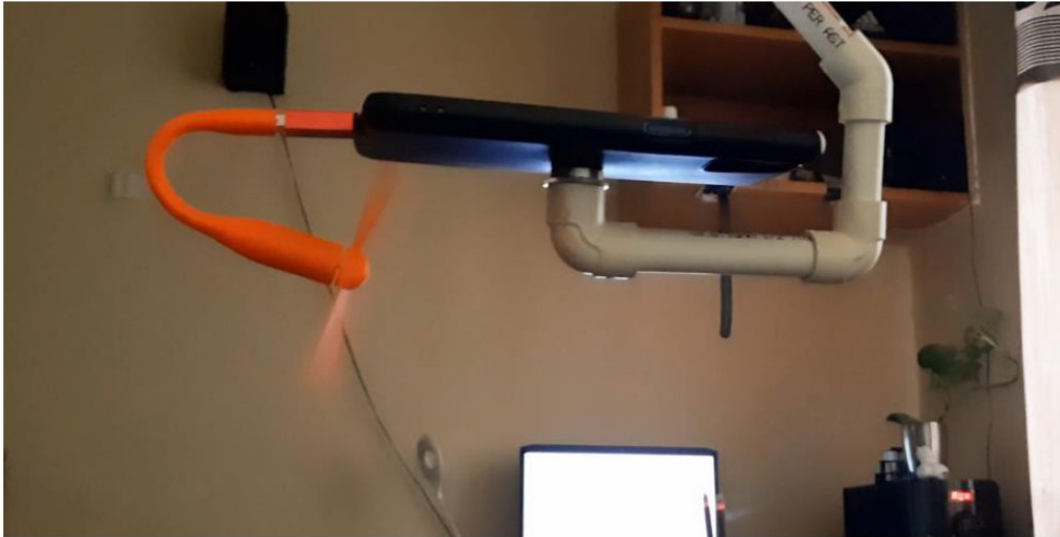

Fig 178 . USB fan

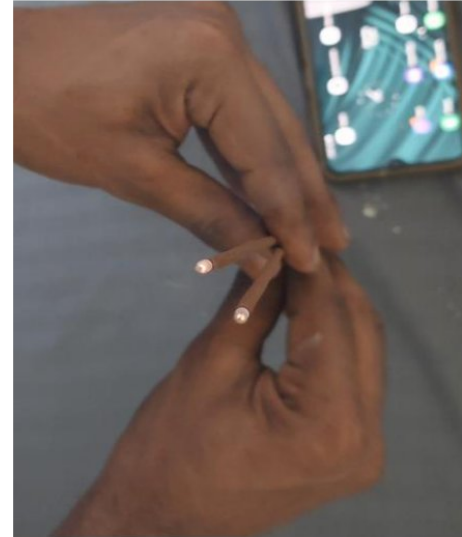

Fig 179 . Clear video

Insight

It was found that the fan was quite effective in keeping away the fumes from the camera lens and the resultant video was more clear. But it had a bit of vibration.

12.11.2 Using a centrifugal laptop fan



Fig 180 . Centrifugal fan



Fig 181 . Centrifugal fan 2

Insight

Since the centrifugal fans blows air in a parallel direction to the mobile phone it was more effective compared to the USB fan.

It showed no vibrations and was also comparatively silent, making these type of fans more suitable for the design

12.12 Testing Proposed Solutions – Mirror concept

When the device is above the users eye level he or she may not be able to see the area being covered in the video. To tackle this situation a mirror can be used which lies above the mobile phone and can give the user an idea about the things being recorded. It needs to be adjustable according to the users view.



Fig 182 . Mirror Concept

12.13 Eye Movement Analysis

It was noted during the interview that the user often forgets the dialogues or speeches that he is supposed to say and it would be better if he has some reference or some notes while recording the video. So while providing such a notepad it shouldn't be very obvious that he or she is referring the notes while speaking. So an experiment was conducted to verify the areas where it would be possible to attach a notepad without making it obvious that the user is referring it. So one mobile was placed in the centre surrounded by sticky notes which were numbered from 1 to 13 and the user was asked to look at each of them in sequence and his reactions were recorded

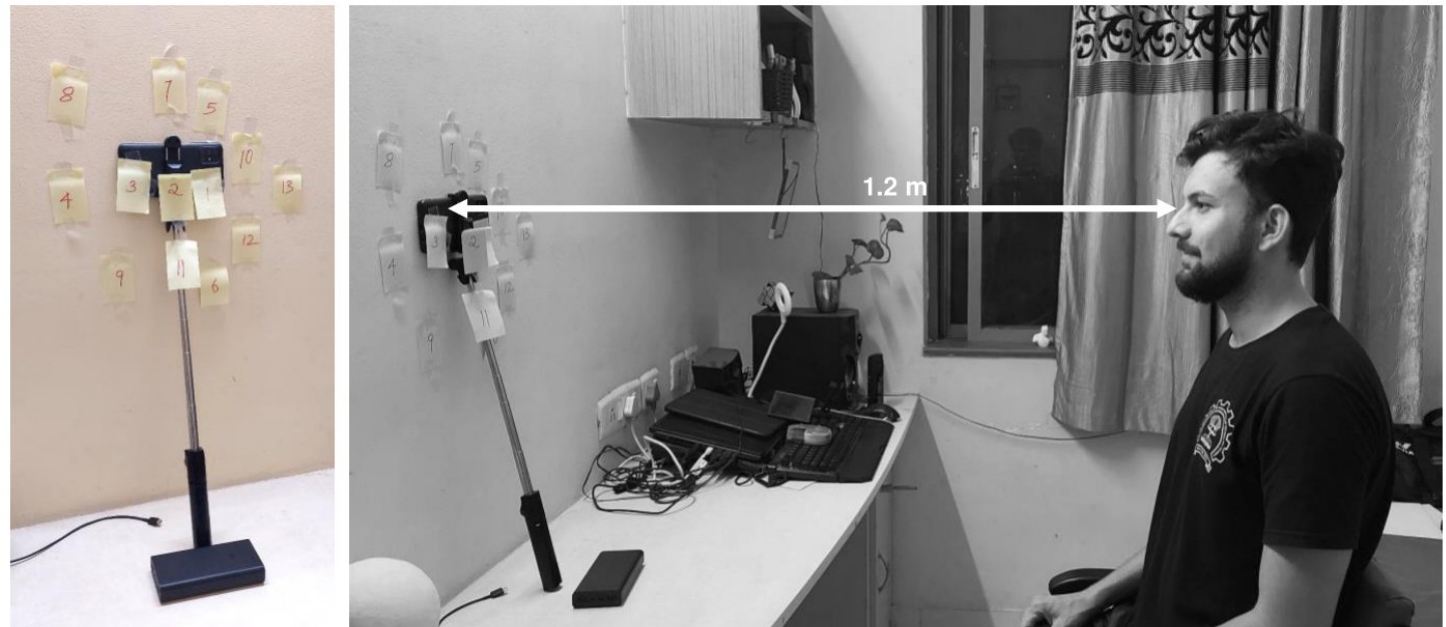

Fig 183 . Eye movement analysis

12.14 Eye Movement Experiment



Fig 184 . Eye movement experiment

Insight

After the experiment it was found that the most suitable places for attaching the notepad were number 1, 2 and 5.

In these spots the user's eyes were not making it obvious that he's referring a notepad in front

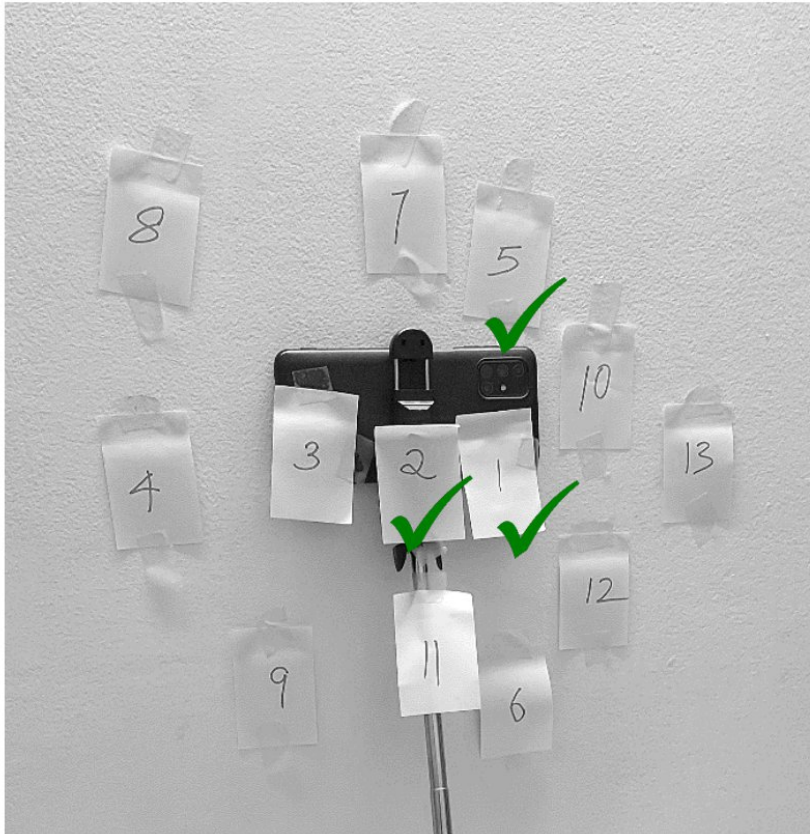

Fig 185 . Experiment set up

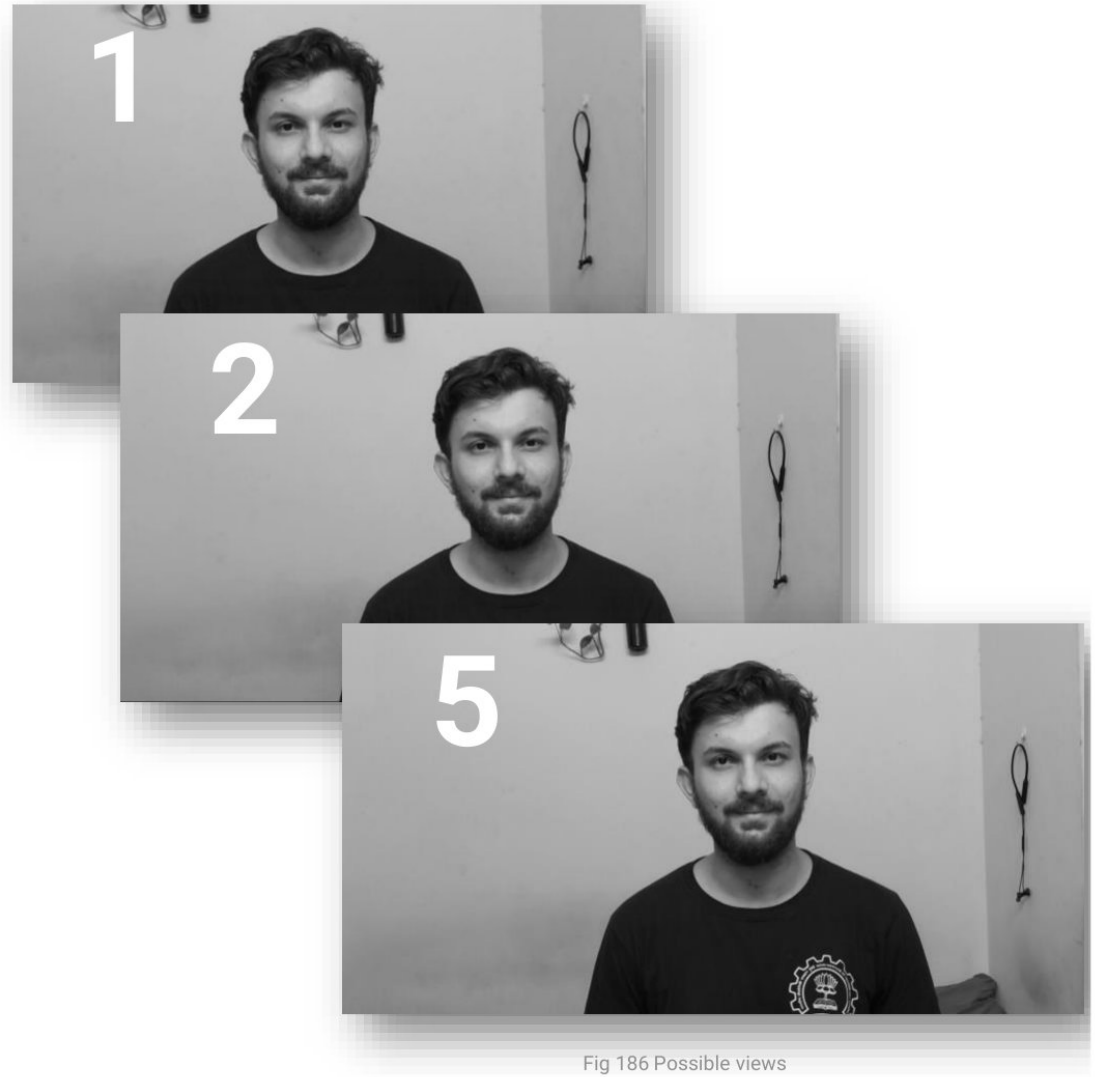

Fig 186 Possible views

12.15 3D Model

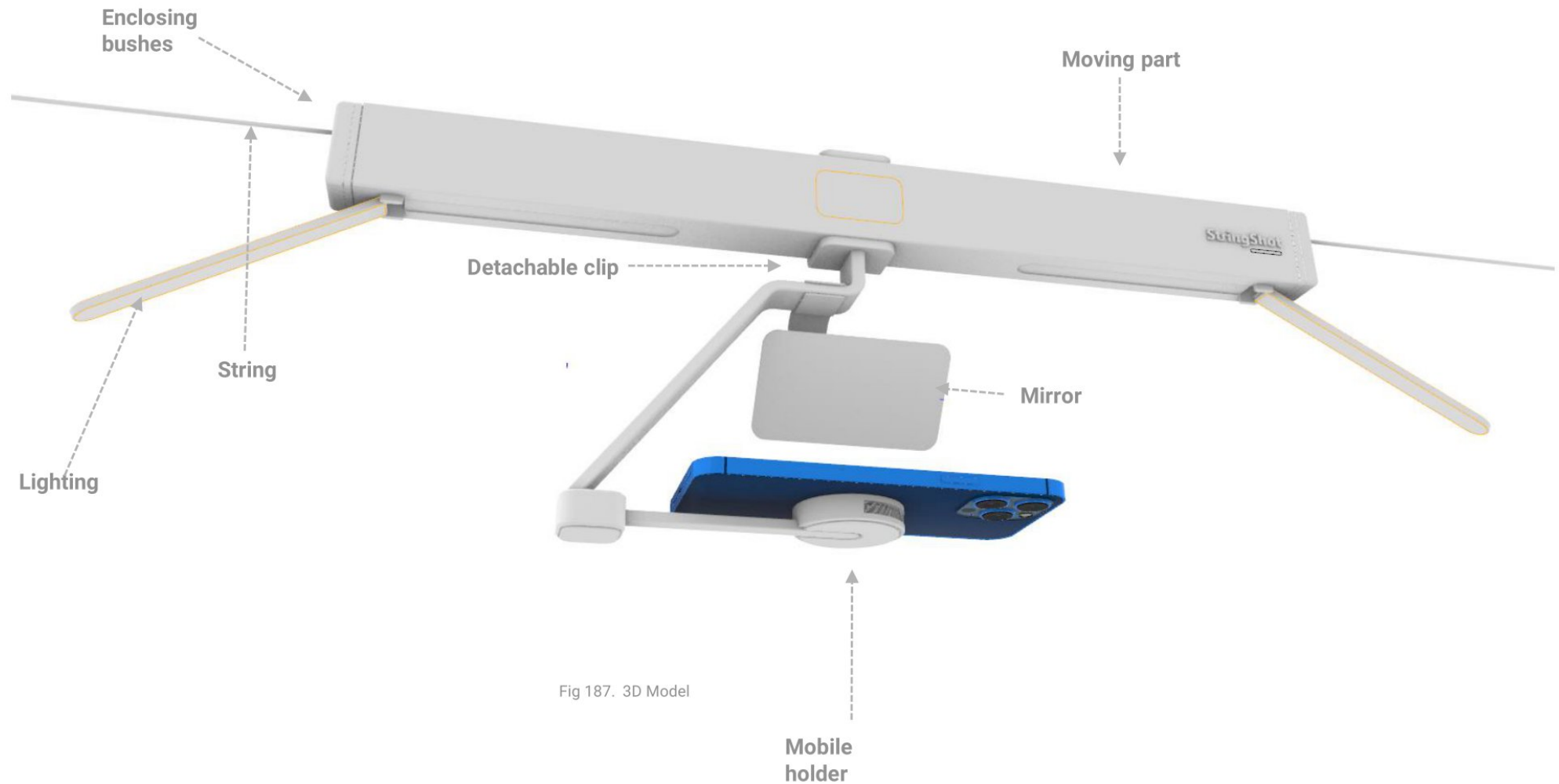

Fig 187. 3D Model

The design has a moving part which can respond to the users hand gestures. All the sensors, wheels and the connections are hidden inside the aluminium tube which is concealed from both sides using plastic enclosures. At bottom there are LEDs which can come down when required to illuminate the scene. The phone can get oriented in any direction right below the moving part keeping the centre of gravity of the system intact.

12.16 Mock up –

A mock up of the final product was made under to test the usability and it was tested by pulling it on a string.

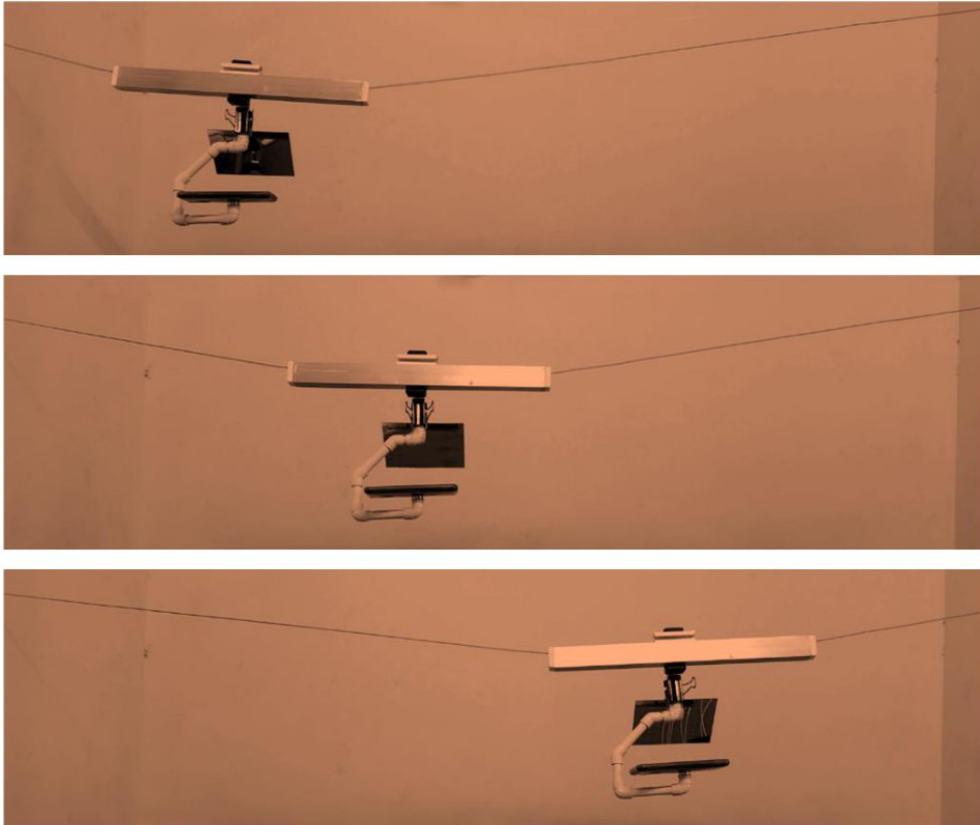

Fig 188 . Mock up testing

12.17 **User** interaction

The user can hover his hand in front of the device and the device can follow it using sensors.



Fig 189 .User Interaction

12.18 Charging detail

The final product will have a rechargeable battery and it will have a type C charging port located on one of the sides of the plastic enclosures.

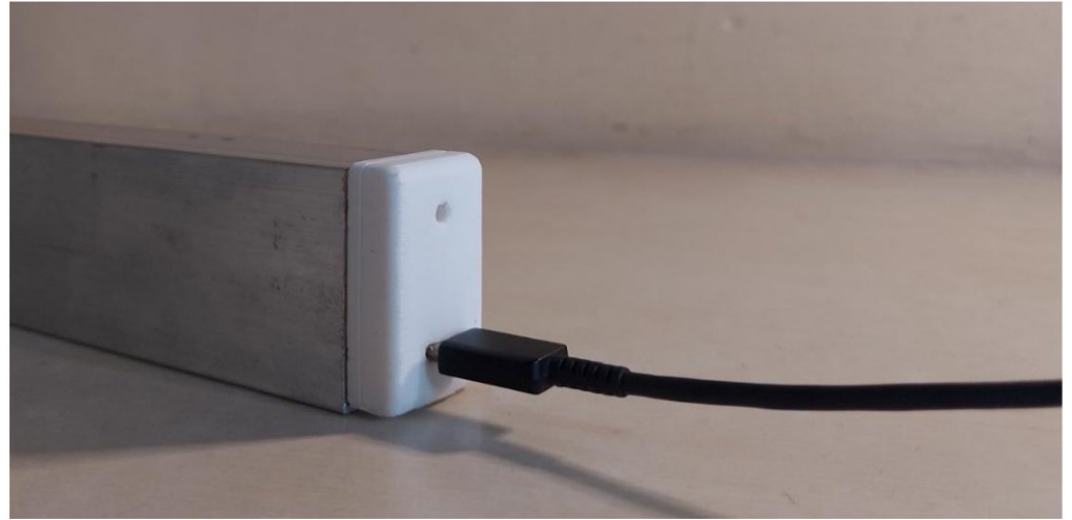

Fig 190 . Charging detail

13. Dimensional Details

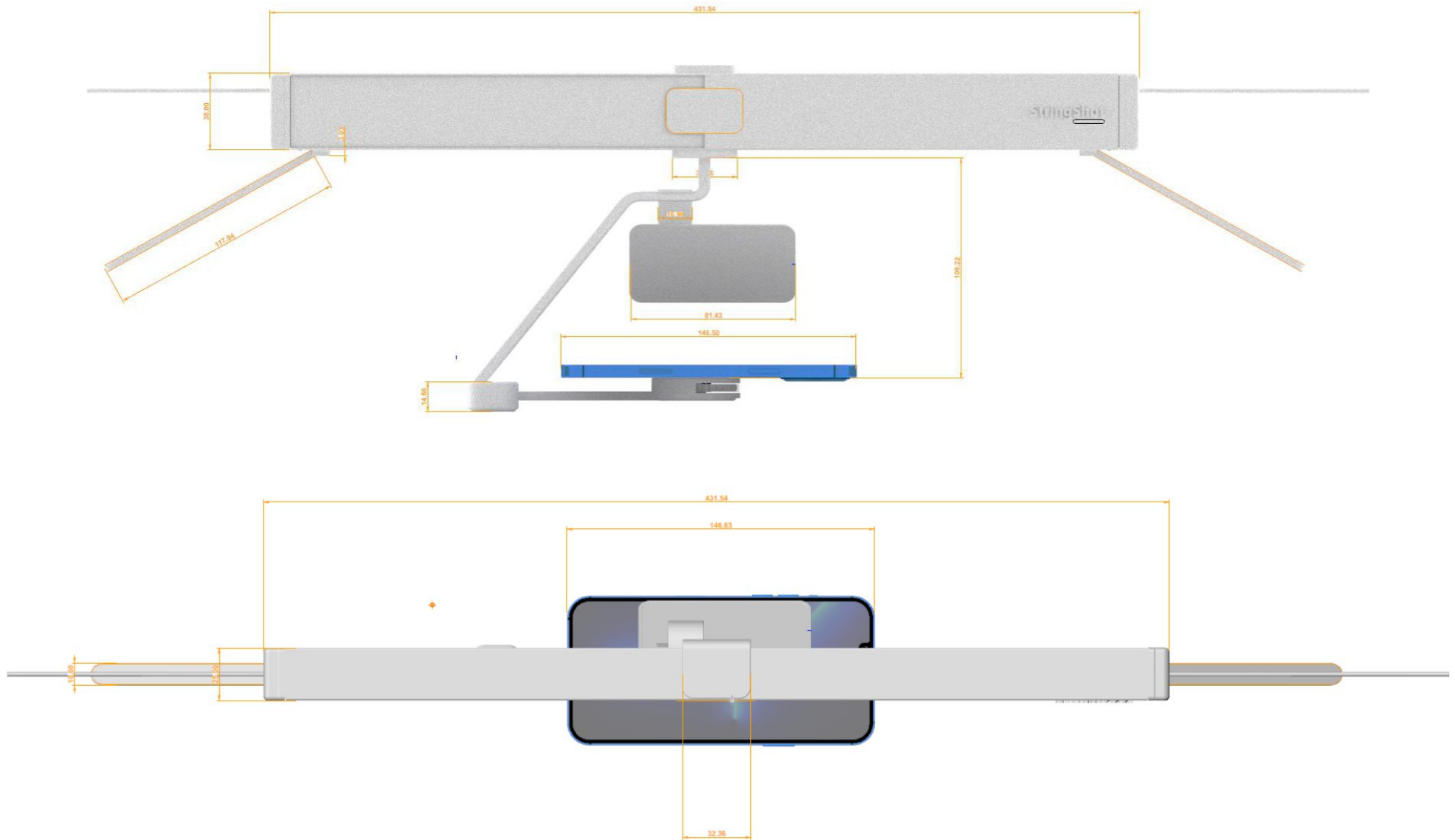
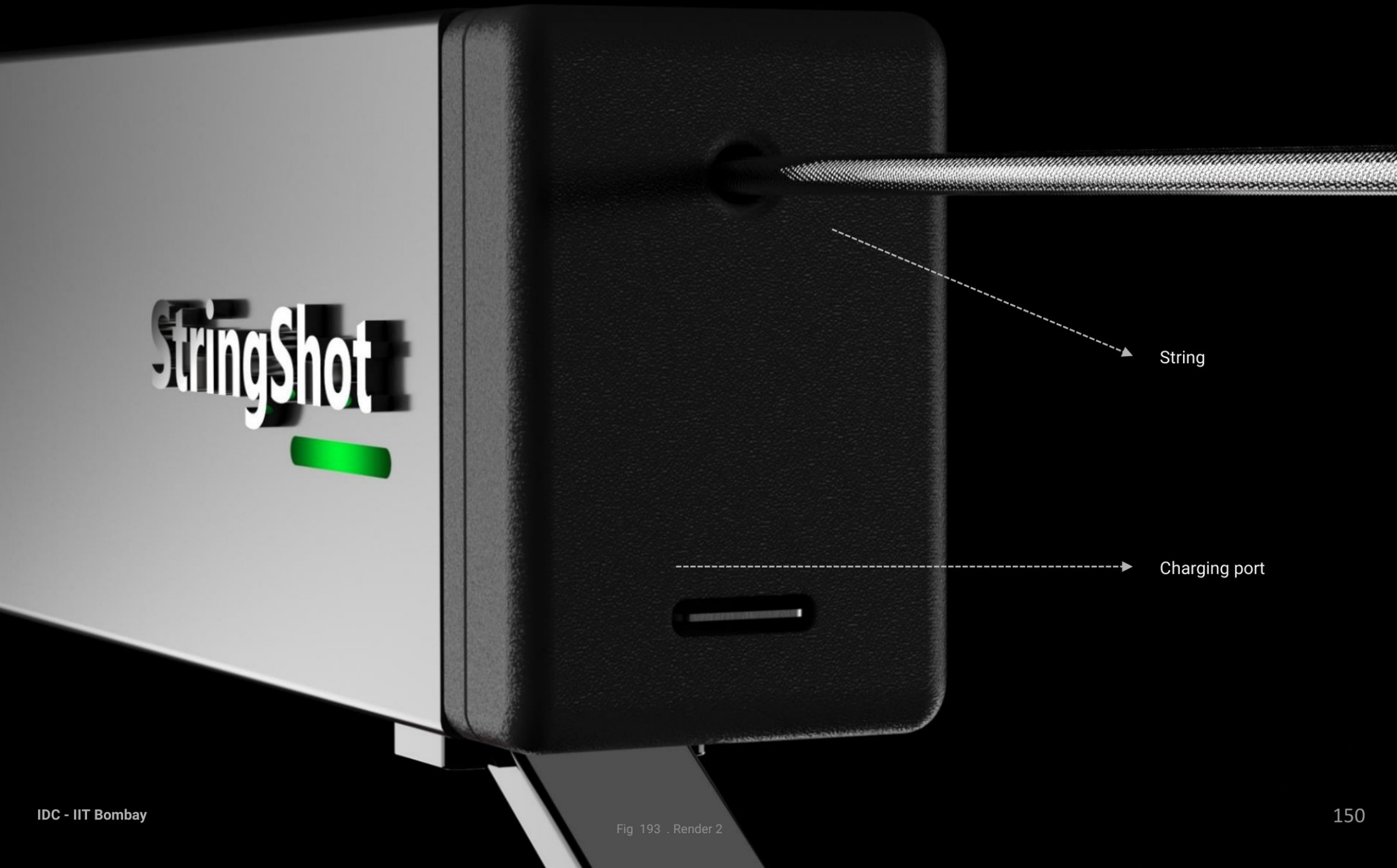

Fig 191 . Dimensional details

14. Renderings



StringShot



StringShot

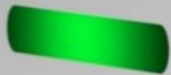

String

Charging port

Power Button

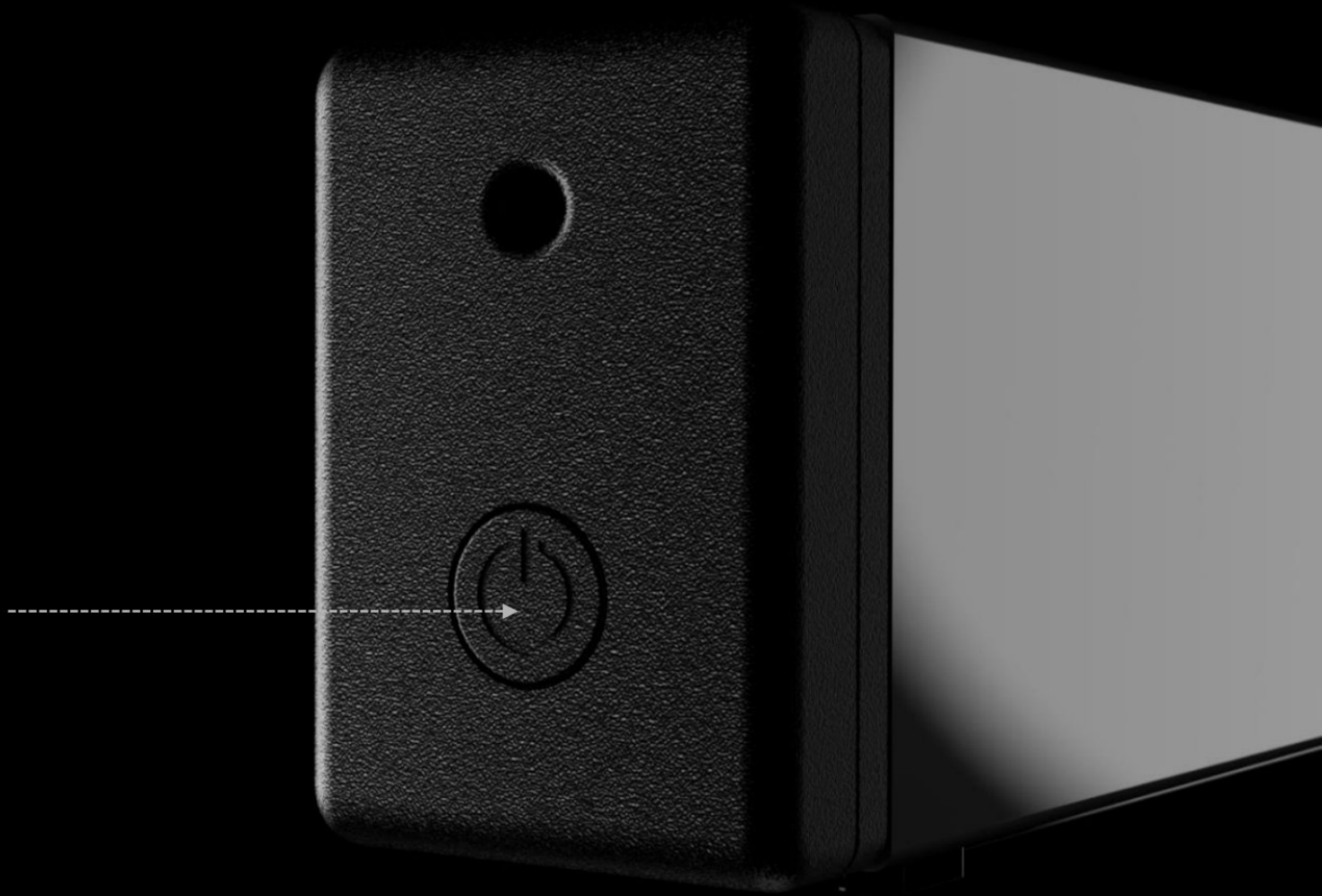

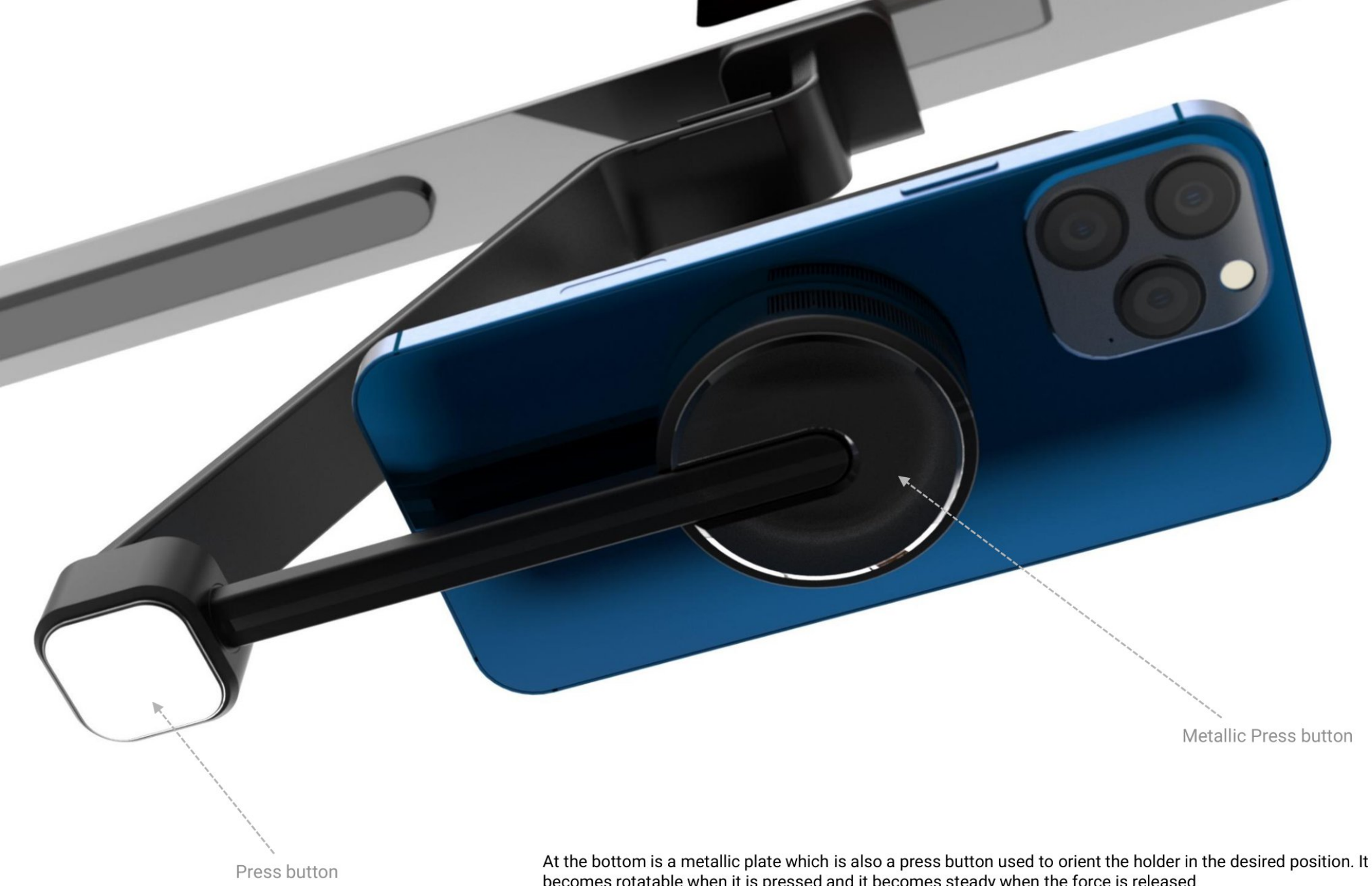

At the bottom is a metallic plate which is also a press button used to orient the holder in the desired position. It becomes rotatable when it is pressed and it becomes steady when the force is released

Same mechanism works for the axis also.





The figure shows the control button for the fan.



The notepad cum mirror rests on the device using a clipping mechanism. It can be attached or detached very conveniently as per the will of the user.

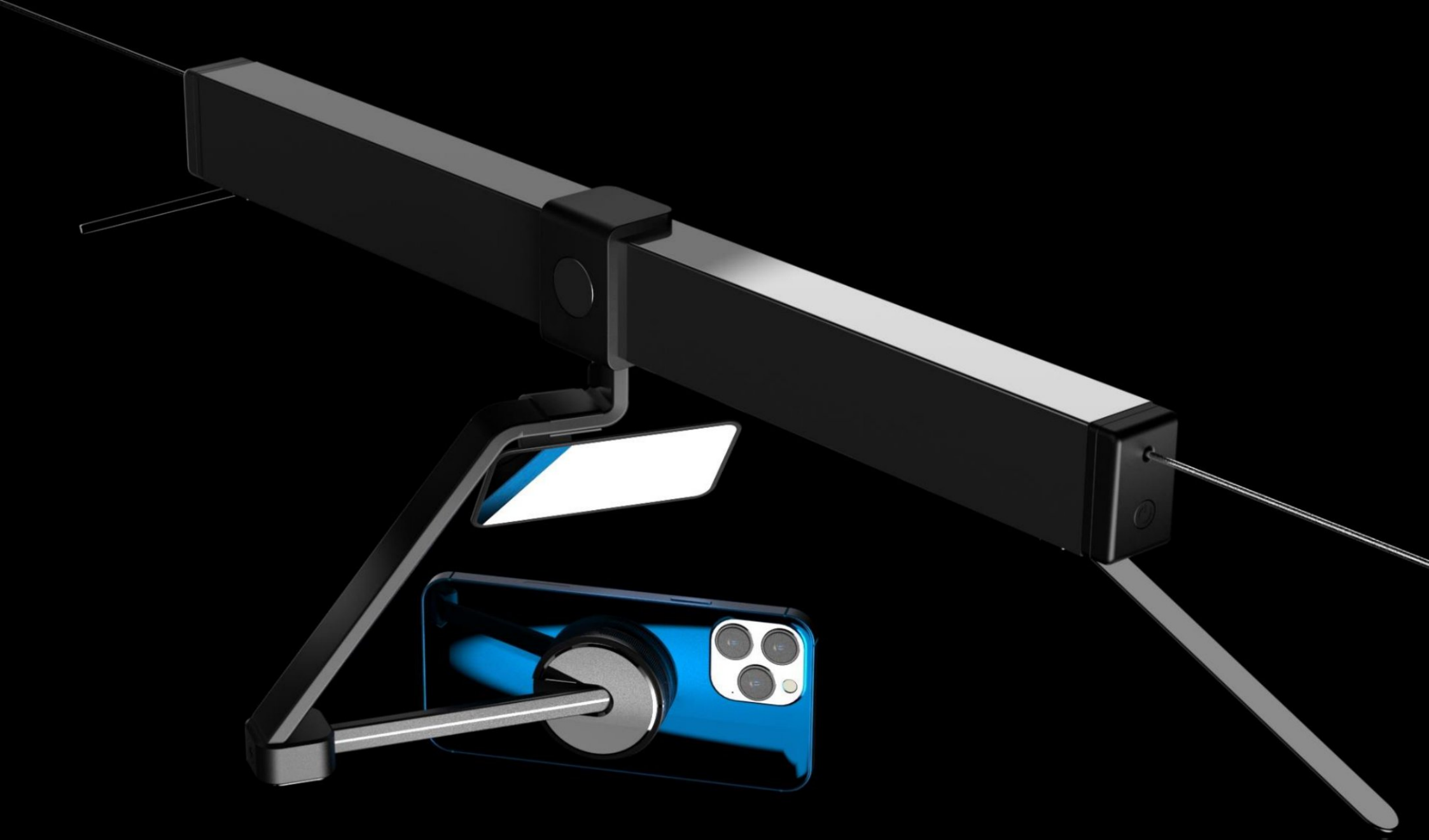

Stringshot can attain any orientation
since center of gravity remains intact



Notepad Attachment

An erasable notepad is incorporated into the device which the user can use to write down important points and which can be magnetically attached to the back of the holder. It is positioned in such a way as to not make it obvious that the user is using a reference.

Rubber frame

Mirror

Magnetic sheet

Notepad

The cross sectional details of the mirror attachment is as showed



Fig 201. Render 9

15. Pre Jury feedback

- If possible include a feature to add one more mobile phone for simultaneous recording from a different angle



16. Updated
Final Design



Fig 202 . Render 10

Swing arm

A new feature of swing arm was introduced into the product which could rotate and could hold one more additional mobile phone if required. The phone could be slid along the arm and was counter balanced by a weight on the opposite side which could be slid as well.



Fig 203 . Render 11

Rotatable holder and arm

The rotatable arm and holder ensure that the phone can be oriented in any direction as desired by the user

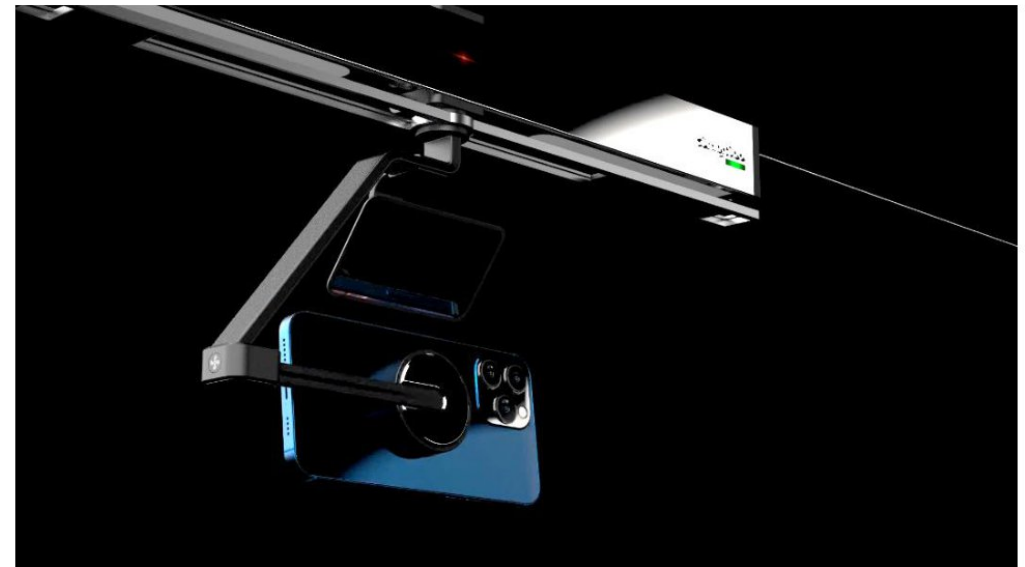
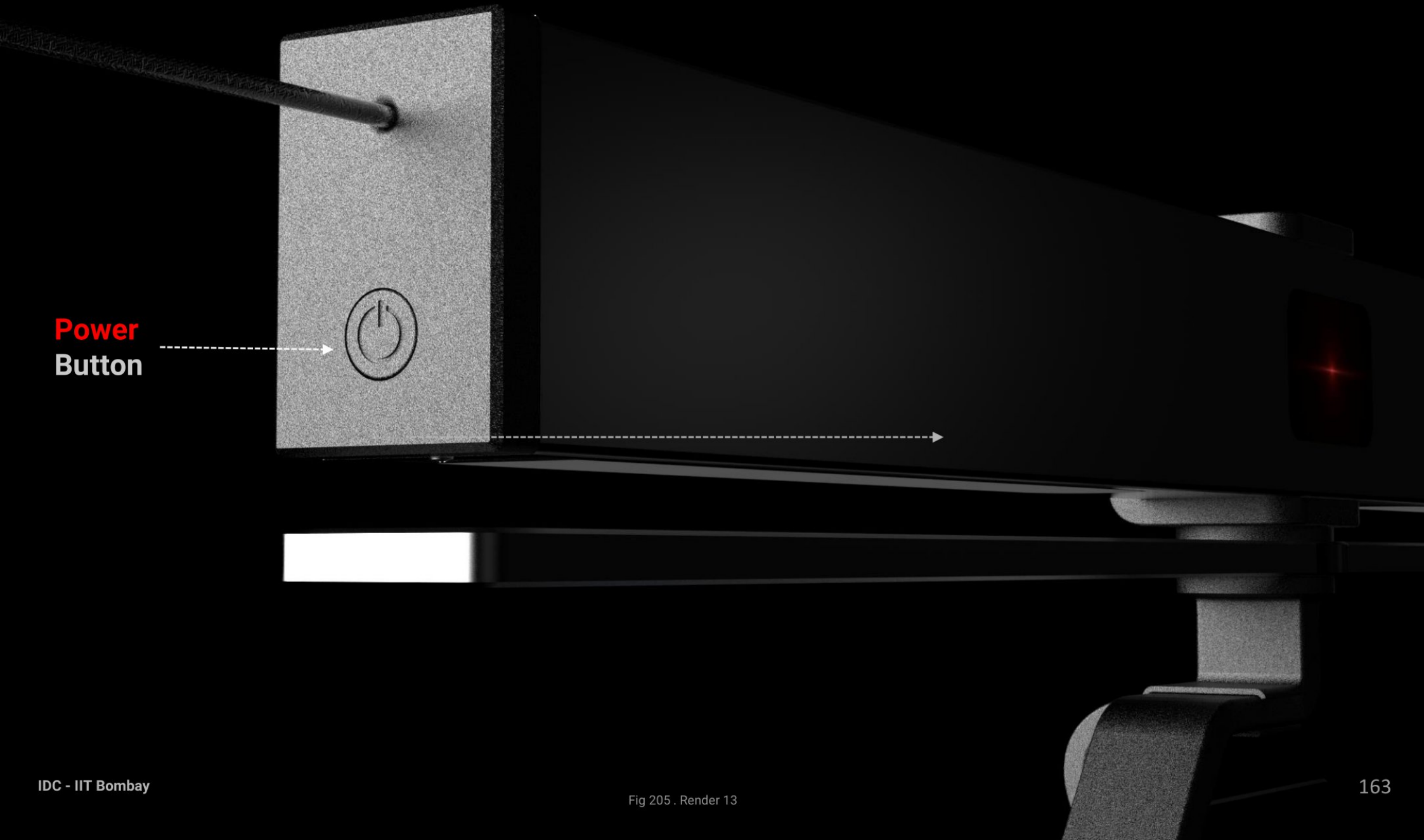
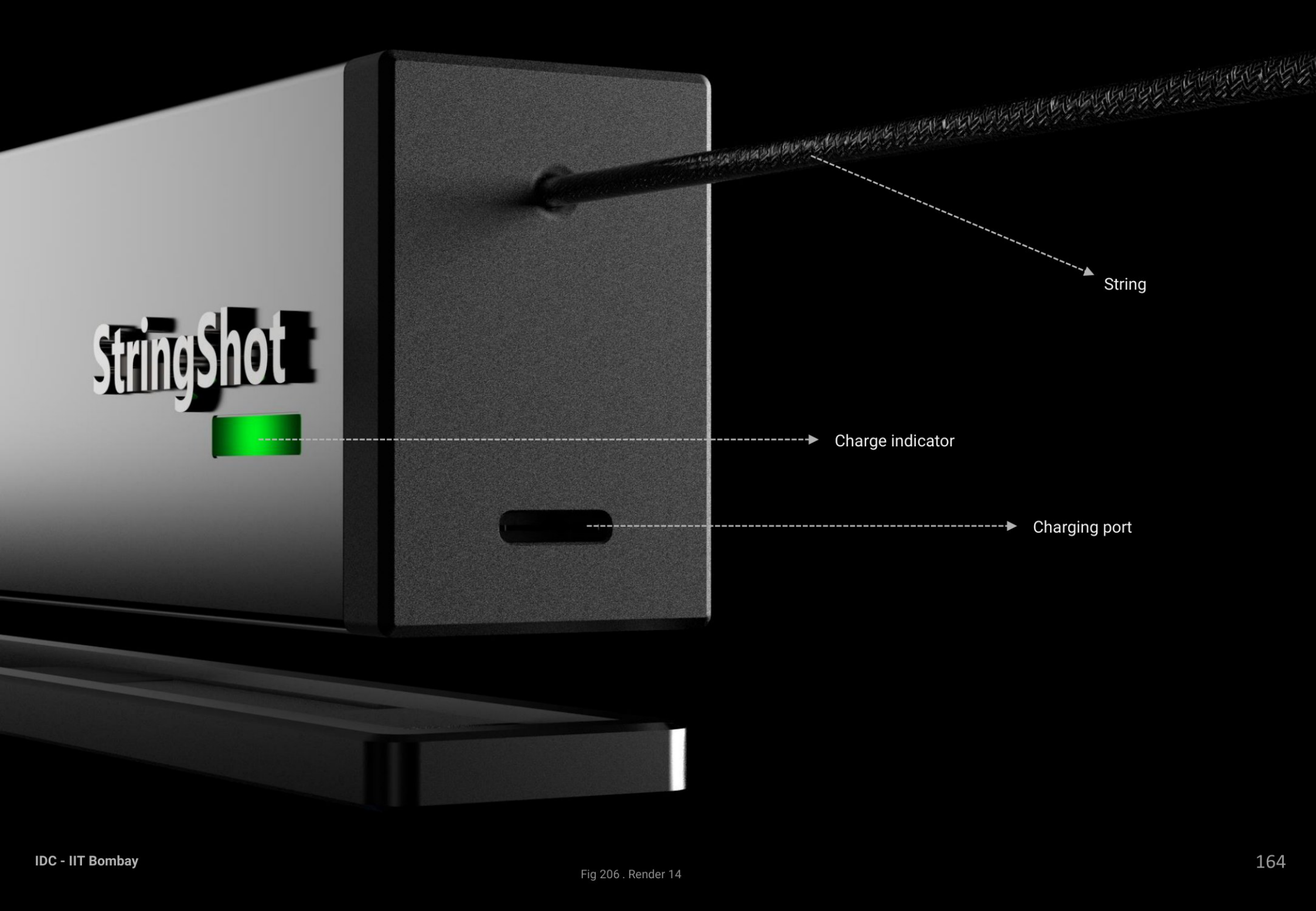

Fig 204 . Render 12

End Capping details



**Power
Button**



StringShot

String

Charge indicator

Charging port

Spring loaded LED Lights

The device would have spring loaded LED lights at the bottom which lights up to illuminate the scene. It can be used in the resting position or in the aligned position by pressing it.



Fig 207 . Render 15



Bluetooth Shutter

A Bluetooth shutter will also be provided along with the device to enable the user to control the mobile from a distance if required.



Exploded View

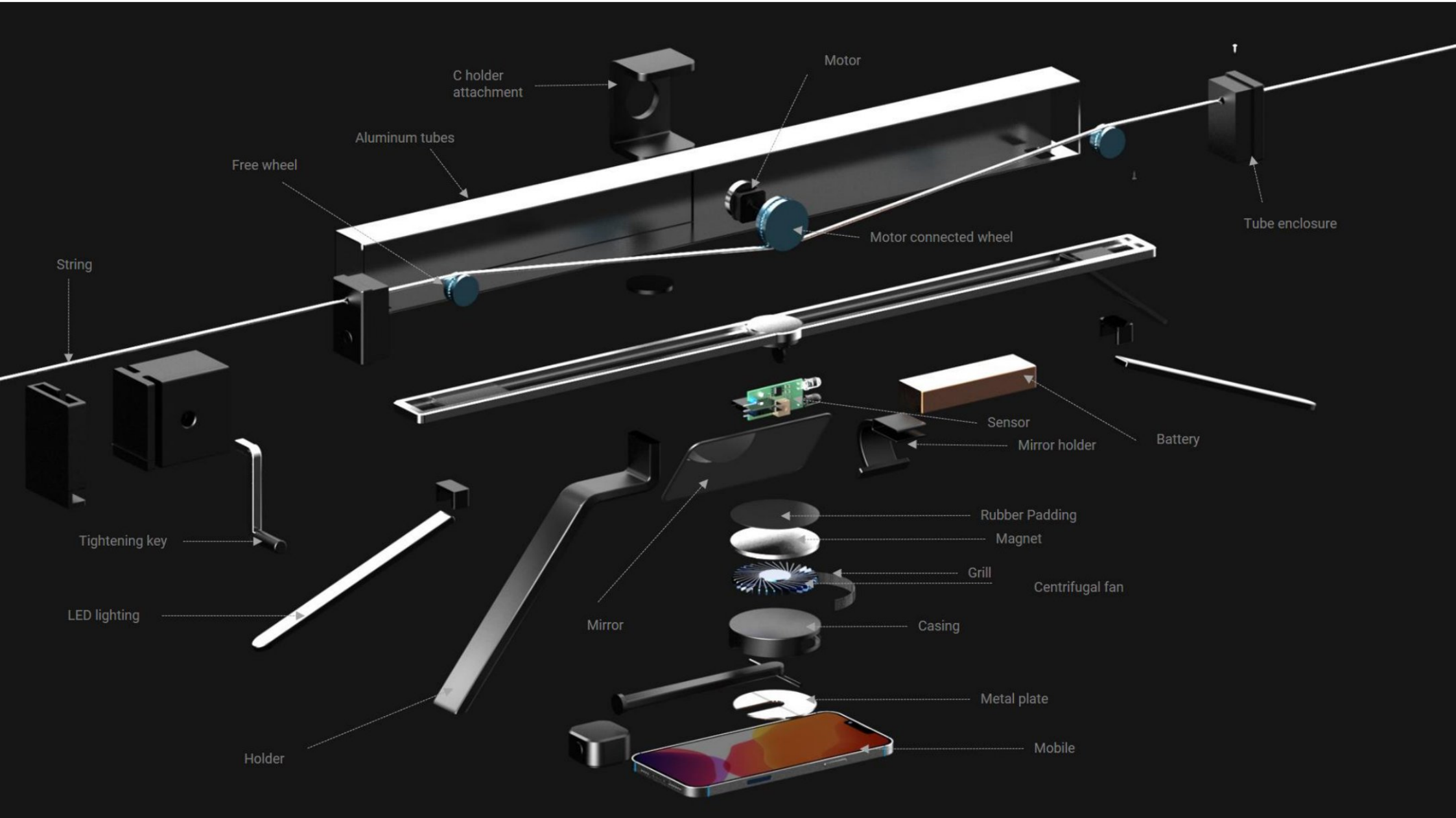

Fig 209 . Render 17

Adjustable Mirror

Behind the erasable notepad is a slightly convex mirror which can be clipped onto the holder in order to help the viewer to verify the area being shot when the mobile is oriented in the top view recording position.

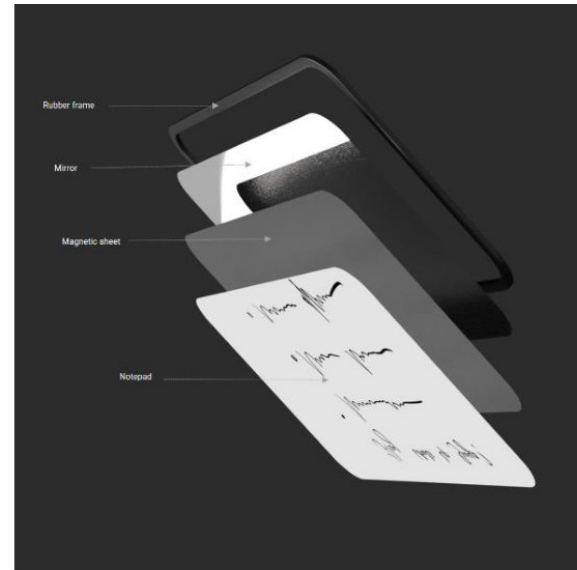
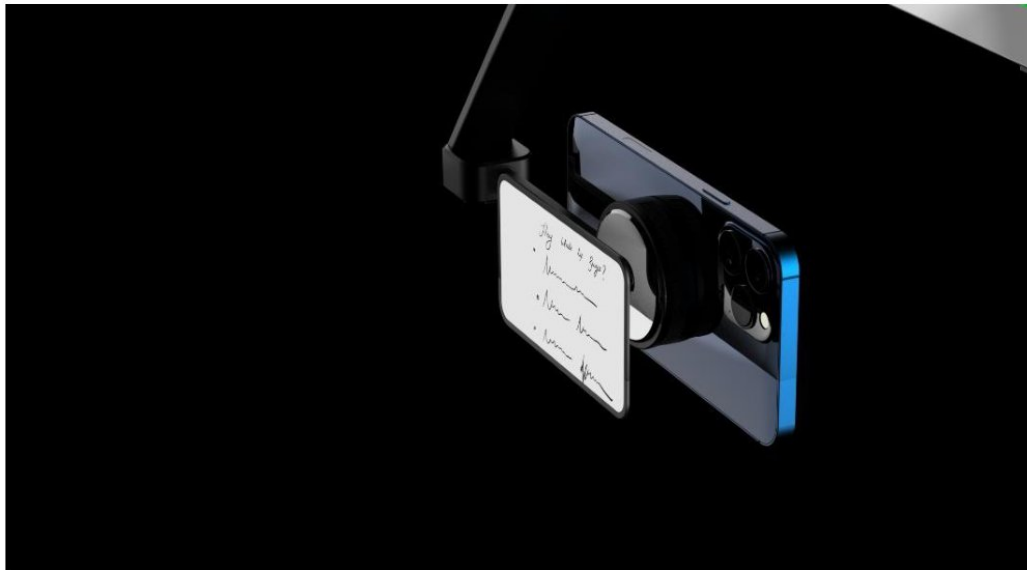
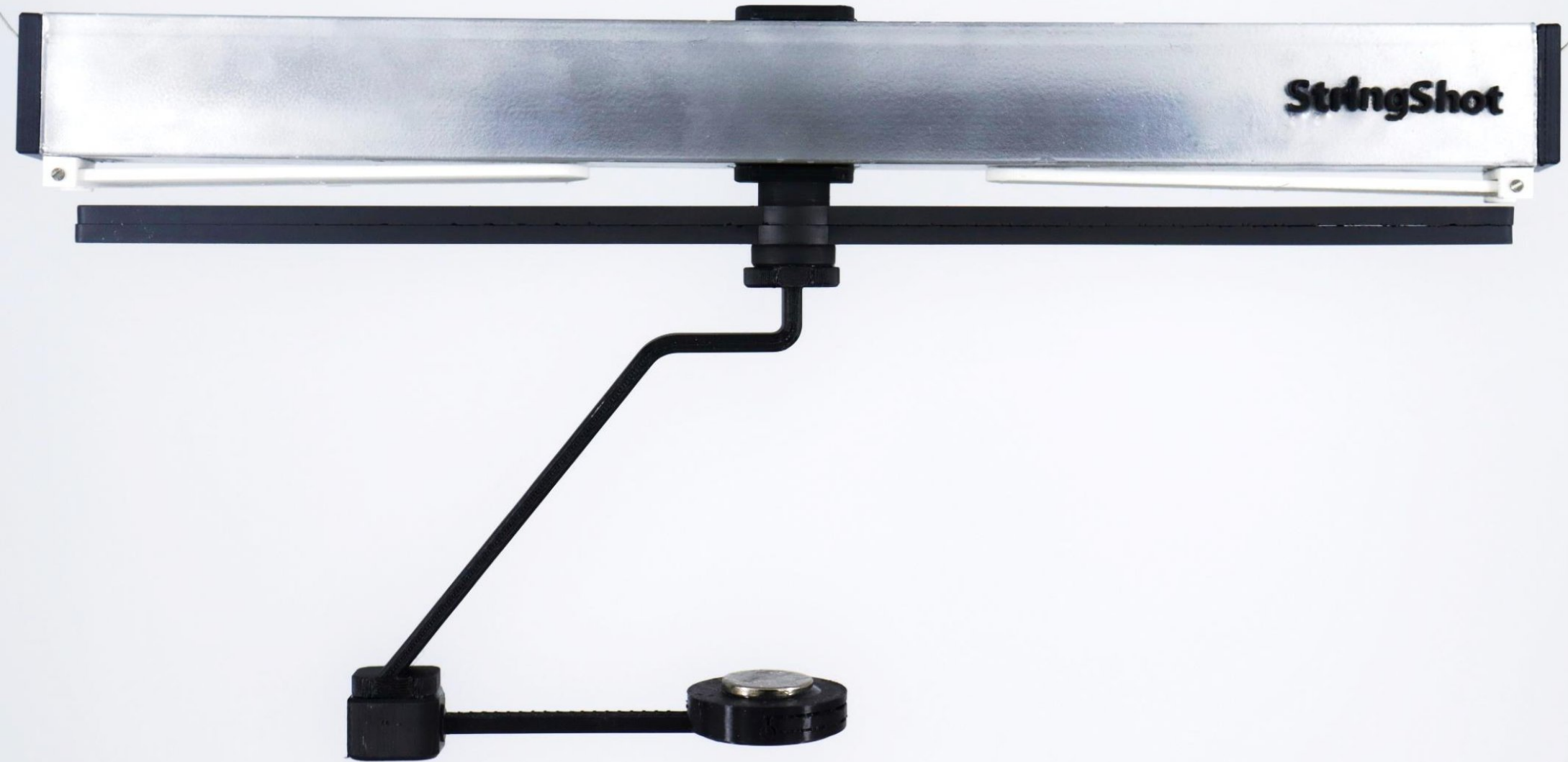

Fig 210 . Render 18

17. Final Mock Up



A final mock up was made to do the user testing and validation of the concept.



18. User Testing

User testing was done with a user in the kitchen environment and the results were analyzed.

The device could effectively record the scene from the top view without much hassle and without taking up any space on the kitchen top and making it crowded as in the case of a normal tripod.



Fig 213 . User testing 1

It could be easily oriented in any direction and orientation that the user intended and was convenient to use.



Fig 214 . User testing 2

19. Packaging

The device would be packed in a hard casing to ensure safe storage. Anchor bolts will be used for wall attachment to ensure that it can withstand the high tension coming on it while it is tightened. The casing would also include

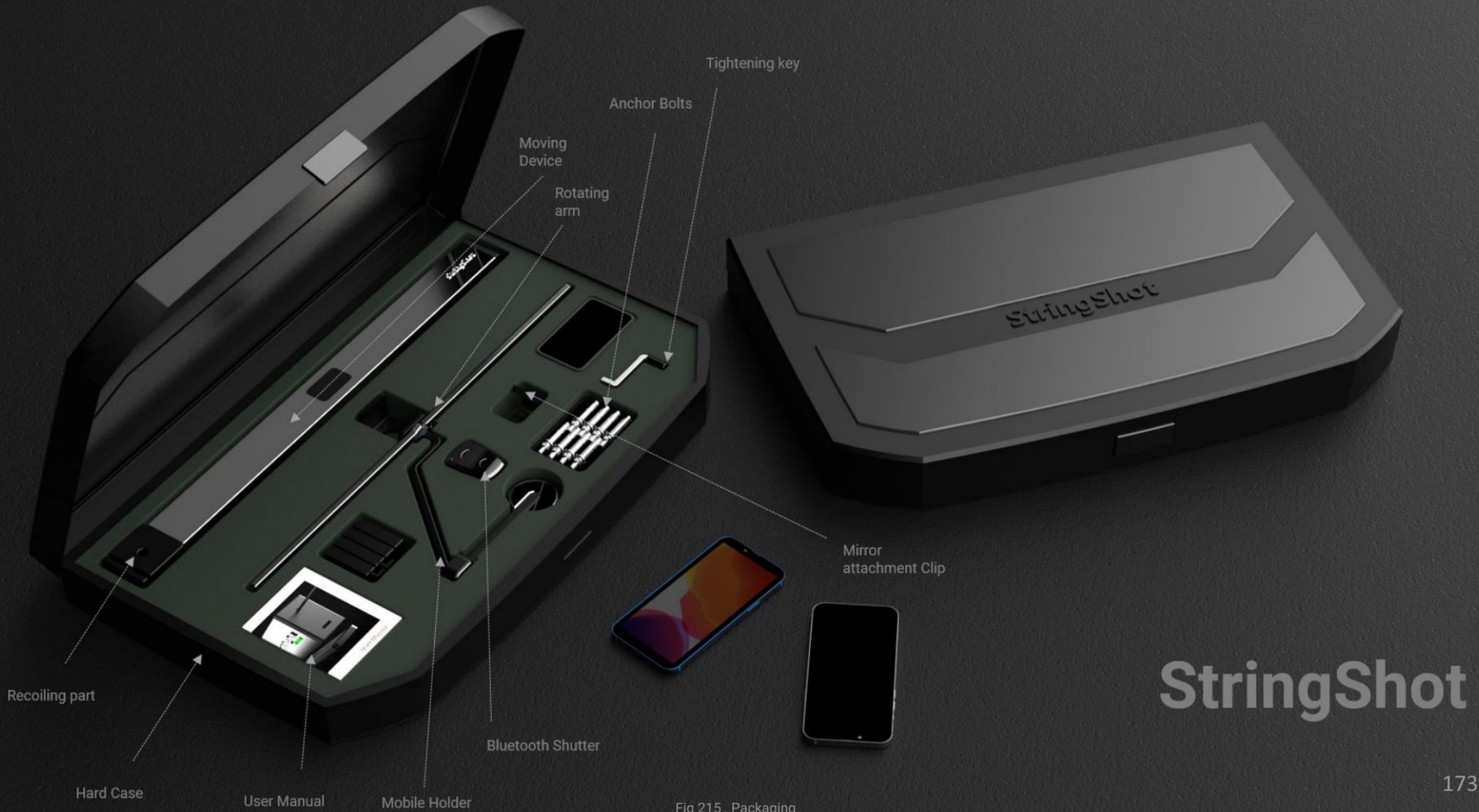

Fig 215 . Packaging

20. Issues resolved



Top View Recording



Fume interference with the lens



Difficulty in shifting and panning the camera from time to time



Inadequate lighting



Tripods taking up kitchen top space



Remembering dialogues



Not able to cross verify area being shot





21. Final Jury Comments

- Slight camera shaking occurred while the camera is set to a new position which could result in a blurry video. Stability is the most important factor while recording a video and it should be ensured.
- Size of the magnet used for attachment should be mentioned.
- Lighting need not be included in the device. It can be attached separately for illuminating the scene well .

22. Possible Solutions

- To ensure stability thicker strings or 2 strings on 2 sides of the end capping can be used.
- The size of the magnets used in the mock up were 2 cm diameter and was quite stable. No issues occurred. However the bigger the magnet size , the better the stability. The ideal size would be 3cm or above.
- Lighting can be excluded form the device if wanted. But it should be placed in such a position and orientation that the shadow of the device itself is not formed in the video.

23. Future Scope

- Can be Upgraded model with a Fully Automatic gesture controlled Device
- App can be developed which can control the device
- Option to Preset rotations, panning distance , moving speed and have an interactive display.

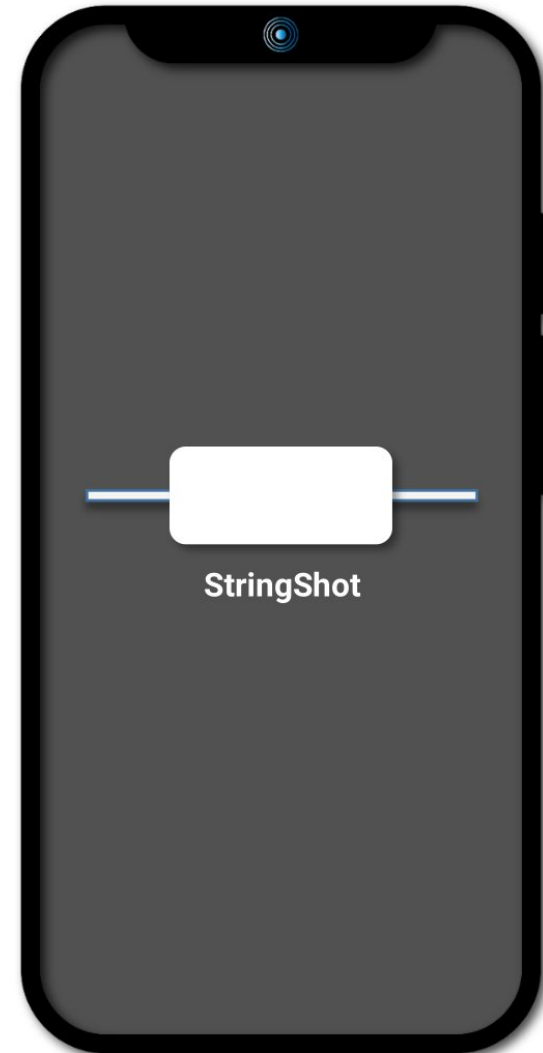



24. References

- <https://www.semrush.com/blog/youtube-stats/>
- <https://www.globalmediainsight.com/blog/youtube-users-statistics/>
- <https://thoughtcatalog.com/january-nelson/2019/01/types-of-youtubers/>
- <https://www.adorama.com/alc/tripod-buying-guide-what-photographers-need-to-know/>
- <https://www.adobe.com/creativecloud/video/hub/ideas/types-of-youtube-channels>
- <https://invideo.io/blog/youtube-statistics/>
- <https://www.youtube.com/trends/articles/covid-impact/>
- <https://vidiq.com/blog/post/coronavirus-the-impact-on-youtube-and-youtubers/>