

Electric mobility vechile for adventure ride

Submitted in partial fulfilment of the requirements

Of the degree of Master of Design

by

SukantaMaharana

Roll No. 176130001

Supervisor:

Prof. P Kumaresan



Industrial Design Centre

INDIAN INSTITUTE OF TECHNOLOGY BOMBAY

(2019)

Acknowledgement

Firstly, I would like to express my thanks and gratitude to my project guide Prof. P Kumaresan, without whom this project would not have been possible. I also would like to thank Kailash (PD Cell), POC Lab for helping out with my project and model making. Lastly, I would also like to specially thank that studio staff for helping me out with prototypes and my family and friends for being my support during project time.

Sukanta Maharana

Sukanta Maharana.

Contents

1. Introduction	1
1.1 Design brief	
1.2 Background	
1.3 Opportunity Identification	
1.4 Delimitations	
2. Literature Survey	6
2.1 Existing vehicles for adventure sports	
2.2 Working mechanism of the mono bike	
2.3 Working of self-balancing	
2.4 Components of electric mono bike	
2.5 Types of frame construction	
2.6 Bike ergonomics	
2.7 Potential applications of mono bike	
3. Designing the Mono bike.....	15
3.1 Mood board	
3.2 Ideation	

3.3 Concepts

3.4 Concept evaluation

3.5 Bike specification

3.6 Materials used

3.7 Mockups

3.8 Prototyping of POC

References69

List of figures

Figure 1.1 Seating inside Monowheels

Figure 1.2 Standing on the Monowheels

Figure 1.3 Seating on Monowheels

Figure 1.4 Collage of different adventure sports

Figure 2.1 Four wheel ATV

Figure 2.2 Adventure Trike

Figure 2.3 Dirt Bike

Figure 2.4 Monobike

Figure 2.5 Picture to explain self balancing mechanism

Figure 2.6 Components of a electric monobike

Figure 2.7 Types of bike frame

Figure 2.8 Types of bike postures

Figure 3.1 Mood board for the attribute Modern

Figure 3.2 Mood board for the attribute Minimalistic

Figure 3.3 Mood board for the attribute Futuristic

Figure 3.4 - Mood board for the attribute Rugged

Figure 3.5 – Dynamic form exploration

Figure 3.6 – Dynamic form exploration

Figure 3.7 – Dynamic form exploration

Figure 3.8 – Ideation sketch 1

Figure 3.9 – Ideation sketch 2

Figure 3.10 – Ideation sketch 3

Figure 3.11 – Ideation sketch 4

Figure 3.12 – Ideation sketch 5

Figure 3.13 – Ideation sketch 6

Figure 3.14 – Ideation sketch 7

Figure 3.15 – Ideation sketch 8

Figure 3.16 – Ideation sketch 9

Figure 3.17 – Ideation sketch 10

Figure 3.18 – Ideation sketch 11

Figure 3.19 – Line drawing of concept 1

Figure 3.20 – Dimensional drawing of concept 1

Figure 3.21 – 3D Model of concept 1

Figure 3.22 – 3D visualization of the concept

Figure 3.23 – Ideation sketch 13

Figure 3.24 – Ideation sketch 14

Figure 3.25 – 2D render of the concept 2

Figure 3.26 – Ideation sketch 15

Figure 3.27 – line drawings of the concept 3

Figure 3.28 – Line drawing of hub 1

Figure 3.29 – Line drawing of hub 2

Figure 3.30 – Dimensional drawings of the concept

Figure 3.31 – 3D visualization of the concept

Figure 3.32 – Ideation sketch 16

Figure 3.33 – Ideation sketch 17

Figure 3.34 – Line drawing of the concept 4

Figure 3.35 – Dimensional drawings of concept 4

Figure 3.36 – 3D visualization of the concept 4

Figure 3.37 – Ideation sketch 18

Figure 3.38 – Line drawings of the concept 5

Figure 3.39 – Dimensional drawing of the concept 5

Figure 3.40 – 3D visualization of the concept 5

Figure 3.41 – 3D visualization of the concept 5

Figure 3.42 – scale model of the concept

Figure 3.43 – Scale model of the concept 5

Figure 3.44 – Scale model of the concept 4

Figure 3.45 – Line drawing of the POC 1

Figure 3.46 – 3D visualization of the POC 1

Figure 3.47 – Line drawing of the POC 2

Figure 3.48 – 3D visualization of the POC 2

Figure 3.49 – Components used in Prototyping

Figure 3.50 – Pictures of working on the full scale working prototype

Figure 3.51 – Pictures of working on the full scale working prototype

Figure 3.52 – Pictures of the scale model of the proposed sports ground

Figure 3.53 – Picture of the business model

Figure 3.54 – Ideation sketch of the logo

Figure 3.54 – Development of the logo.....83

Introduction

An **adventure** is an exciting experience which is risky and typically bold. It may involve some potential for physical danger. Adventurous experiences create psychological arousal. According to adventurer André Malraux ,"*If a man is not ready to risk his life, where is his dignity?*". Adventurous activities are undertaken for excitement or recreation. Adventurous activities like exploration may lead to gains in knowledge. The various criteria that make an experience to be considered an adventure are being remarkable, involving adversity and enhancing personal growth. Regardless of their innate challenges, mono bikes continue to capture the interest of adventurers. The difficulty of stabilizing, starting, stopping, turning, and controlling monocycles at low speeds makes them challenging to operate. It has advantages like zero turning radius, minimum footprint, easy parking and freedom of ground clearance. The use of higher clearance and higher traction enables access on trails and forest roads that have rough and low traction surfaces. Non availability of mono wheel adventure ride creates an opportunity to design special vehicle class that doesn't exist in the current vehicular market.

1.1 Design brief

Designing electric monobike for adventure ride with focus on objective aspects of design like mechanical ergonomics (seat height,handlebar placement etc.), frame configurations, layout of major components (battery, controller etc..) along with subjective aspects of design like styling and human machine interface. Identifying the target customers and researching them for benchmarks . Identifying materials for rugged construction to withstand high stress on each components of the machine.

1.2 Background

A monowheel is a one-wheeled vehicle where the rider sits either within the wheel, on top of it or next to it. The wheel is driven by smaller wheels pressing against the inner rim. Most of the monowheels are single-passenger vehicles, although multi-passenger models are also built. Mono wheels with Hand-crank or pedal-powered are built in the late 19th century. The mono wheels built in the 20th century are motorized. Monowheels are generally used for entertainment and fun purposes. Now they are being used for serious transportation.



Figure 1.1 Seating inside Monowheels



Figure 1.2 Standing on the Monowheels

Figure 1.3 Seating on Monowheels

1.3 Opportunity Identification

The global off-road vehicle market is expected to grow at a CAGR of 3.80% during 2018-2026 and estimated to reach \$320 billion by 2026. In India, the adventure travel industry is gaining prominence and estimated to grow at a CAGR of 17.4% from 2017 to 2023 in India. Many multinational companies are about to invest huge capital in research and development of adventure vehicles. The potential manufacturers include

- Polaris Industries
- Honda Motor Co
- Yamaha Motor Co
- BRP Inc
- Arctic Cat
- Kubota Corporation
- Kawasaki



Figure 1.4 Collage of different adventure sports

1.4 Delimitations

The project is intended to develop a framework for electric mono bike. The design is a concoction of designed components like frame, seat, handle bar, body panels and off the shelf components like

suspension, hub motor, balancing mechanism and batteries. The project focuses on generating a chassis suitable for off road adventure rides with robust frame and suspension. A proof of concept is generated to test the feasibility of the design in the off road context. A 3D model is generated with all the aesthetic details as a final submission.

Chapter 2

Literature Survey

2.1 Existing vehicles for adventure sports

2.1.1 All terrain vehicles

An all-terrain vehicle (ATV), also known as quadricycle is a vehicle with a seat straddled by the operator, travels on low-pressure tires, with handlebars for steering control. Designed to handle a wider variety of terrains. Rider operates and sits on these vehicles like a motorcycle. The extra wheels give additional stability at slower speeds. It is a street-legal vehicle in many countries. Engine capacities vary from 49 cc to 1000 cc.

2.1.2 Adventure trike

A **tricycle**, also called **trike** is a human-powered three-wheeled vehicle. Tricycles are used for recreation, shopping, and exercise. Some tricycles are used for commercial purposes. Tricycles are



Figure 2.1 Four wheel ATV

favored for their apparent stability compared to a bicycle but the trike has poor dynamic lateral stability, and care must be taken when cornering to avoid tipping of the trike. A delta tricycle has one

front and two rear wheels. A tadpole tricycle has two front wheels and one rear wheel with rear wheel steering.

2.1.3 Dirt bike

Designed for off-road events to drive on surfaces that are not paved like mud, sand, gravel or snow. Compared to road going counterparts, off-road bikes are lighter and simpler with high ground clearance, long suspension travel and rugged construction with no fairings and little bodywork for less damage in case of spills. The wheels have knobby tires clamped to the rim with a rim lock.



Figure 2.2 Adventure Trike



Figure 2.3 Dirt Bike

2.2 Working mechanism of the mono bike

1. **Outer frame**

2. **Rollers** allow the outer ring to revolve around the inner frame

3. **Inner frame** holds the rollers, power source, drive, and seat.

4. **Power source** could be a petrol engine, an electric motor or pedals.

5. **Drive** usually a friction-type, running against the inside of the outer ring.



Figure 2.4 Monobike

2.3 Working of self-balancing

The mechanism utilizes a 3-axis accelerometer and a 3-axis gyroscope chip to determine if the bike it is tilting over. The motors then activate appropriately to compensate for this falling motion to maintain the mono-wheels upright self-balancing position.

Sense tilt and drive wheels to make robot erect

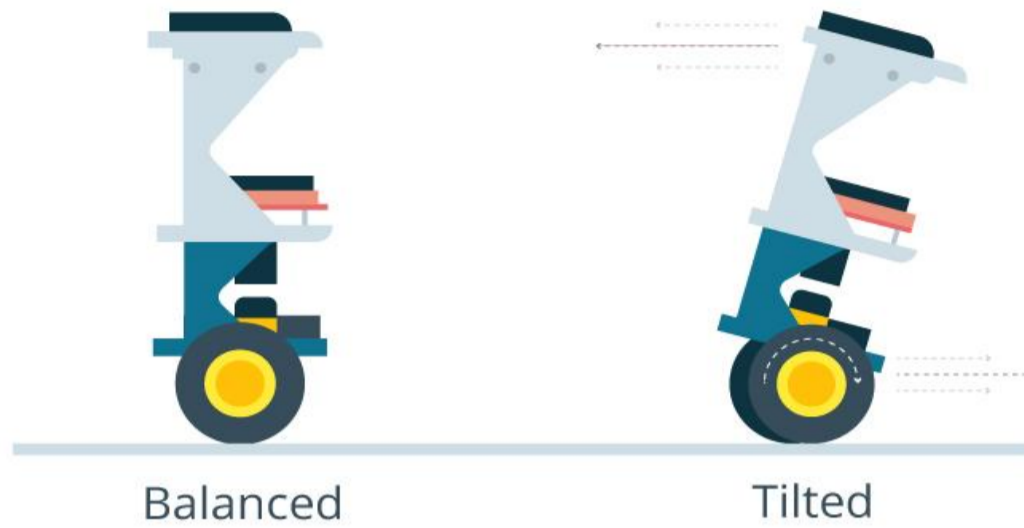
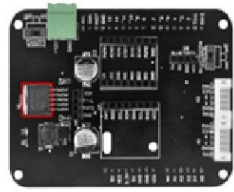

Figure 2.5 Picture to explain self balancing mechanism

2.4 Components of electric mono bike



Main control unit



Voltage regulator



Inertial measurement unit



Motor driver



Li-po battery



Hub motor



Off road tyre



Spoke wheel



Handle bar

Figure 2.6 Components of a electric monobike

2.5 Types of frame construction

A chassis or frame forms a skeleton of a vehicle where all the components are attached to this to lend strength and ability to handle the vehicle. Wide variety of frames exists based on materials, budget and performance limits. Traditionally budget vehicle frames are made of steel tubes, bent and welded. Steel is economical, reasonably strong and suitable for low to moderate performance. Modern vehicle chassis must be stiffer, lightweight and hence, make use of aluminum and alloys. Aluminum can handle performance requirements for mainstream vehicles but high performance vehicles require even robust and lighter materials. To meet these criteria, frames are made of exotic materials like carbon-fiber, titanium and magnesium. Advanced production techniques are employed to make the composites of these materials having hybrid properties. But most of these expensive materials to a large extent are limited to high performance vehicles like Moto GP. Commuter

vehicles generally use chassis made from aluminum or alloys.

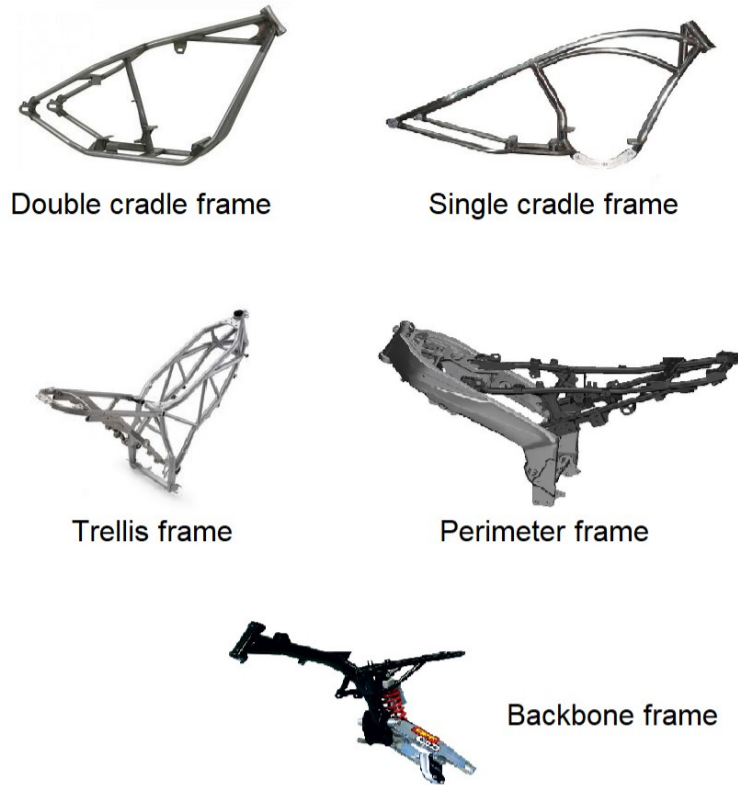

Figure 2.7 Types of bike frame

2.6 Bike ergonomics

2.6.1 Riders triangle

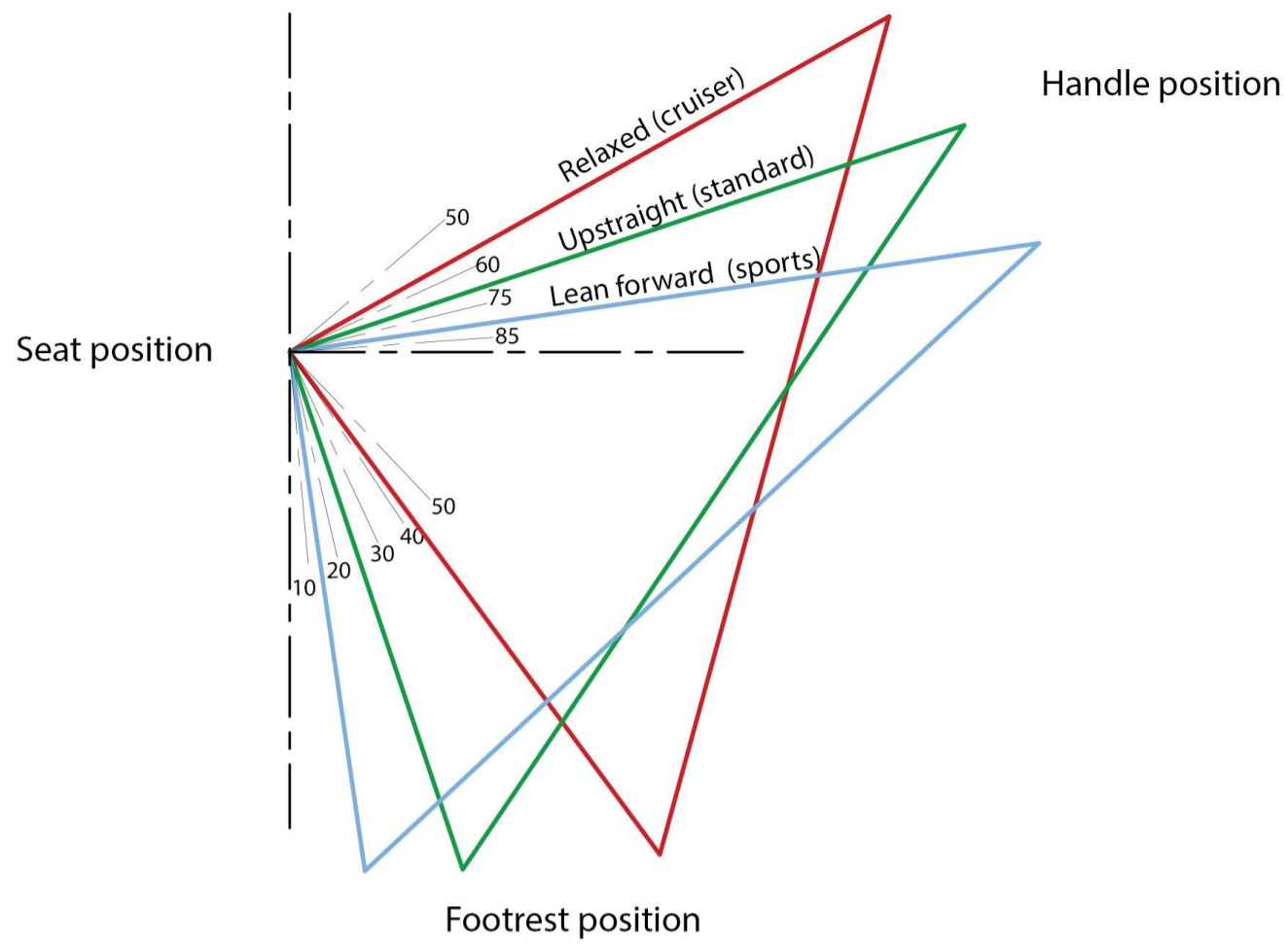

Figure 2.8 Types of bike postures

2.6.2 Dimensions for the bike

Seat height790 mm
Tire rim dia400 mm
Tire width140 to 240 mm
Suspension travel150 mm
Handle width800 mm

2.7 Potential applications of mono bike

1. Personalized Urban transport

A low cost, pollution free all electric vehicle to allows people travel short distances within the city limits without creating added congestion. It can also be used in tandem with public transport as last mile transport from transportation hub to the destination.

2. Adventure sports

With inherent challenge in riding the monowheel, a special class of sport can be introduced to test the skills of the rider involved.

3. Tactical vehicle

Monowheel has unique features that make them stand out from rest of the vehicles like freedom of ground clearance making them all terrain vehicle. Inherently compact, if armored can be used for border patrol, riot and crowd control.

4. Quick response vehicle

Monowheel has zero turning radius and minimum footprint which is suitable for quick response vehicles in dense urban areas. With little modification it can be used as fire fighter, patrol vehicle or ambulance.

Chapter 3

Designing the Mono bike

I started with the mood boards, to visualize look and feel of my product. I took some attributes which I need in my product. There are attributes necessary for my design are modern, minimalistic, futuristic, rugged, etc. Selected some pictures which has these attributes, analyzed them to understand the attributes and its characteristics. Afterwards I started ideation sketching.

3.1 Mood board

3.1.1 Modern



Figure 3.1 Mood board for the attribute Modern

Keywords - Clean, Unibody, Light, Contrast, Sleek, Technology.

3.1.2 Minimalistic



Figure 3.2 Mood board for the attribute Minimalistic

Keywords - simple, moderate, practical, clean, essential, low-key, basic, functional, silent, futuristic.

3.1.3 Futuristic



Figure 3.3 Mood board for the attribute Futuristic

Keywords - Trend setter, miniature, Sci fi, iconic, noble, fluid, clean, and minimal.

3.1.4 Rugged



Figure 3.4 - Mood board for the attribute Rugged

Keywords - Heavy, Tough, Ribbed, Uneven, Imposing, Subtle.

3.2 Ideation

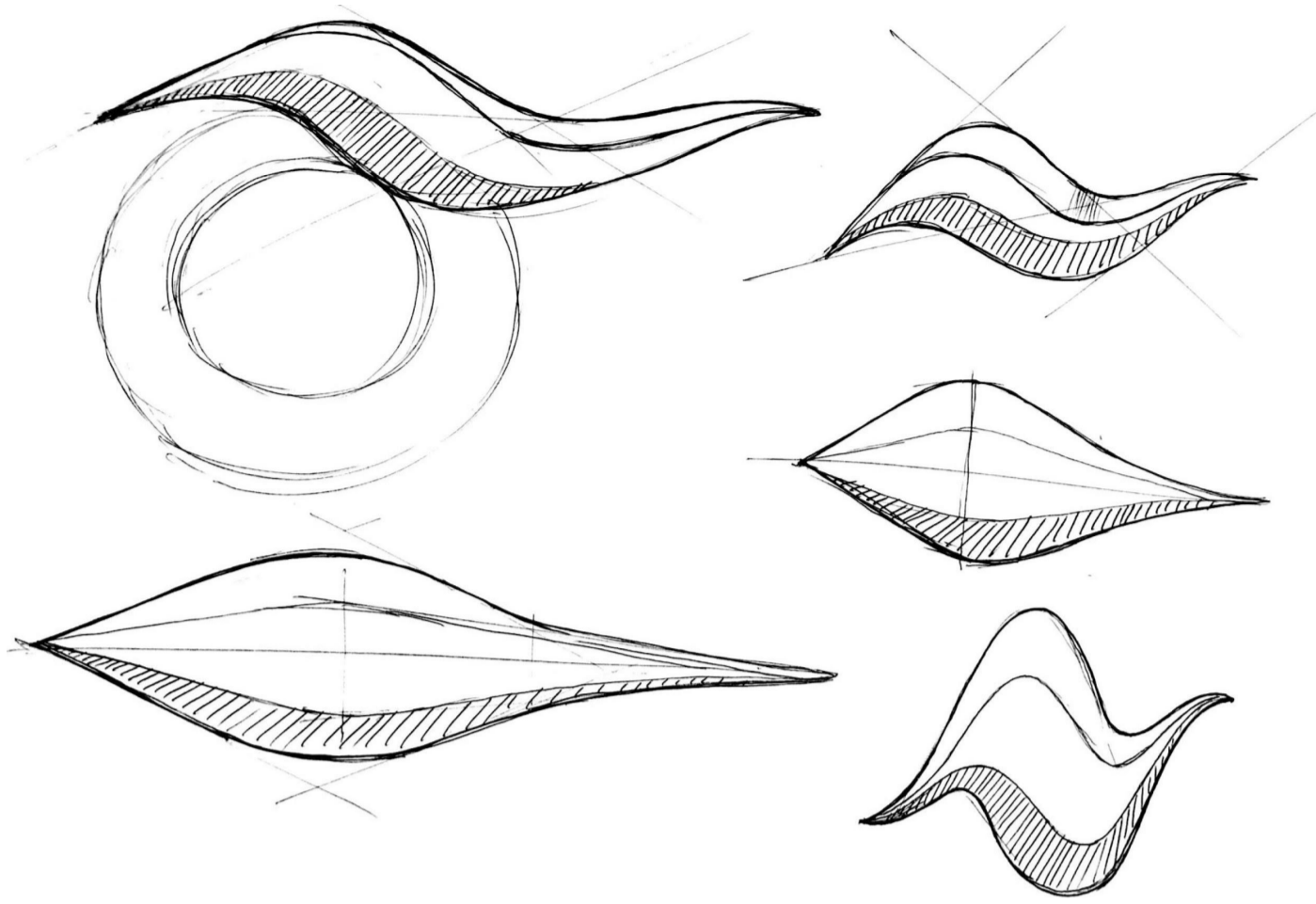

Figure 3.5 – Dynamic form exploration

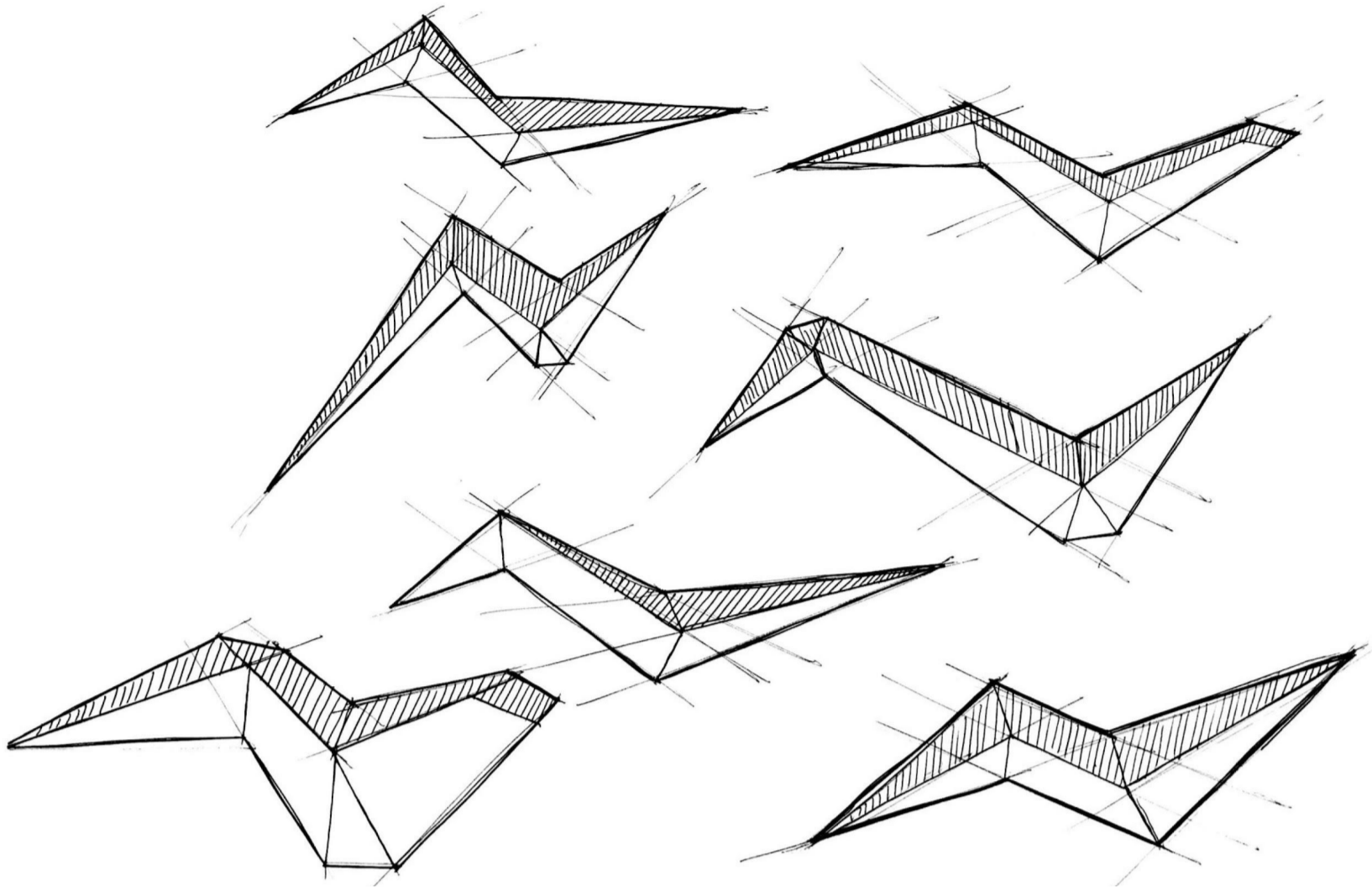

Figure 3.6 – Dynamic form exploration

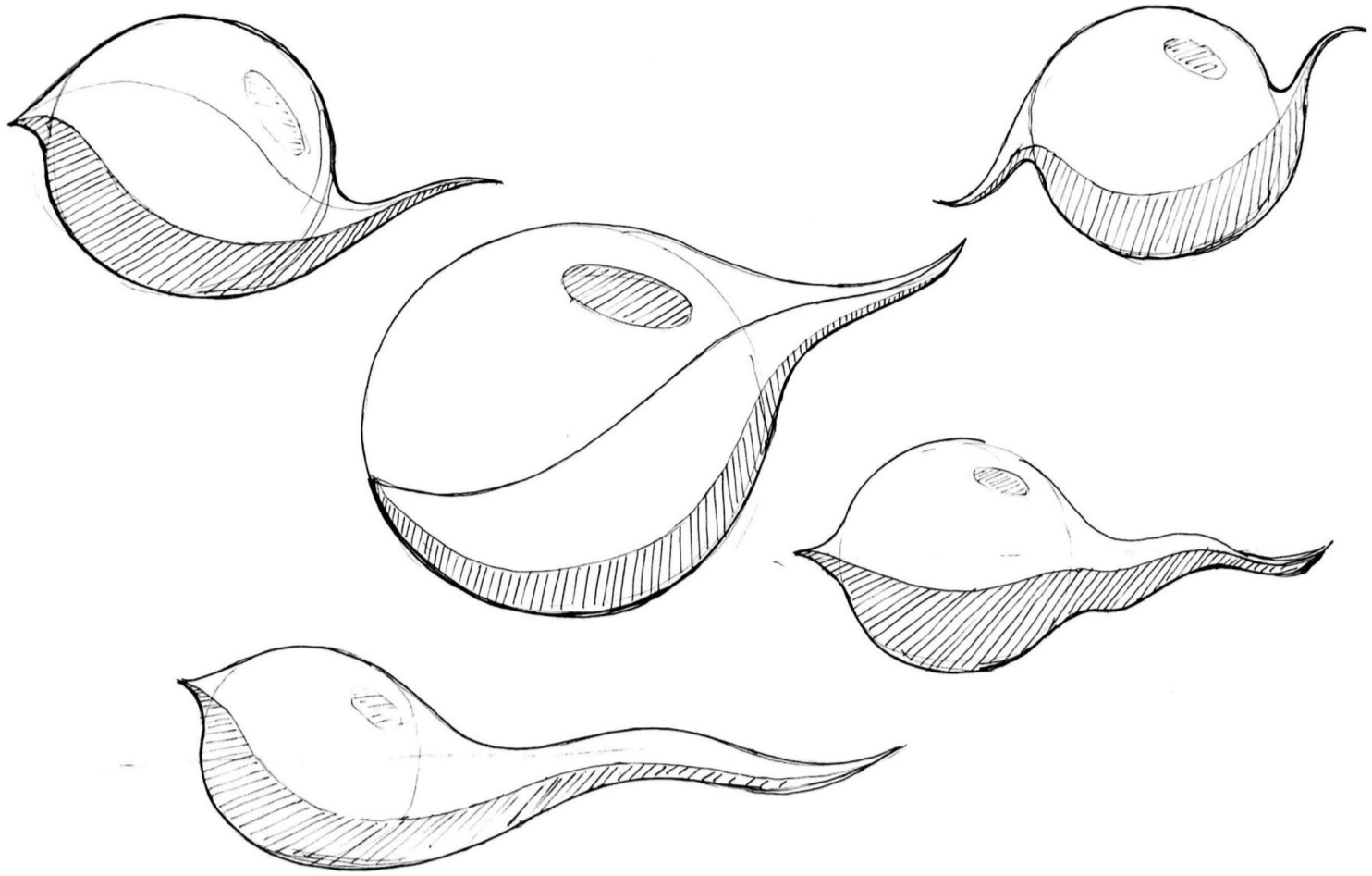

Figure 3.7 – Dynamic form exploration

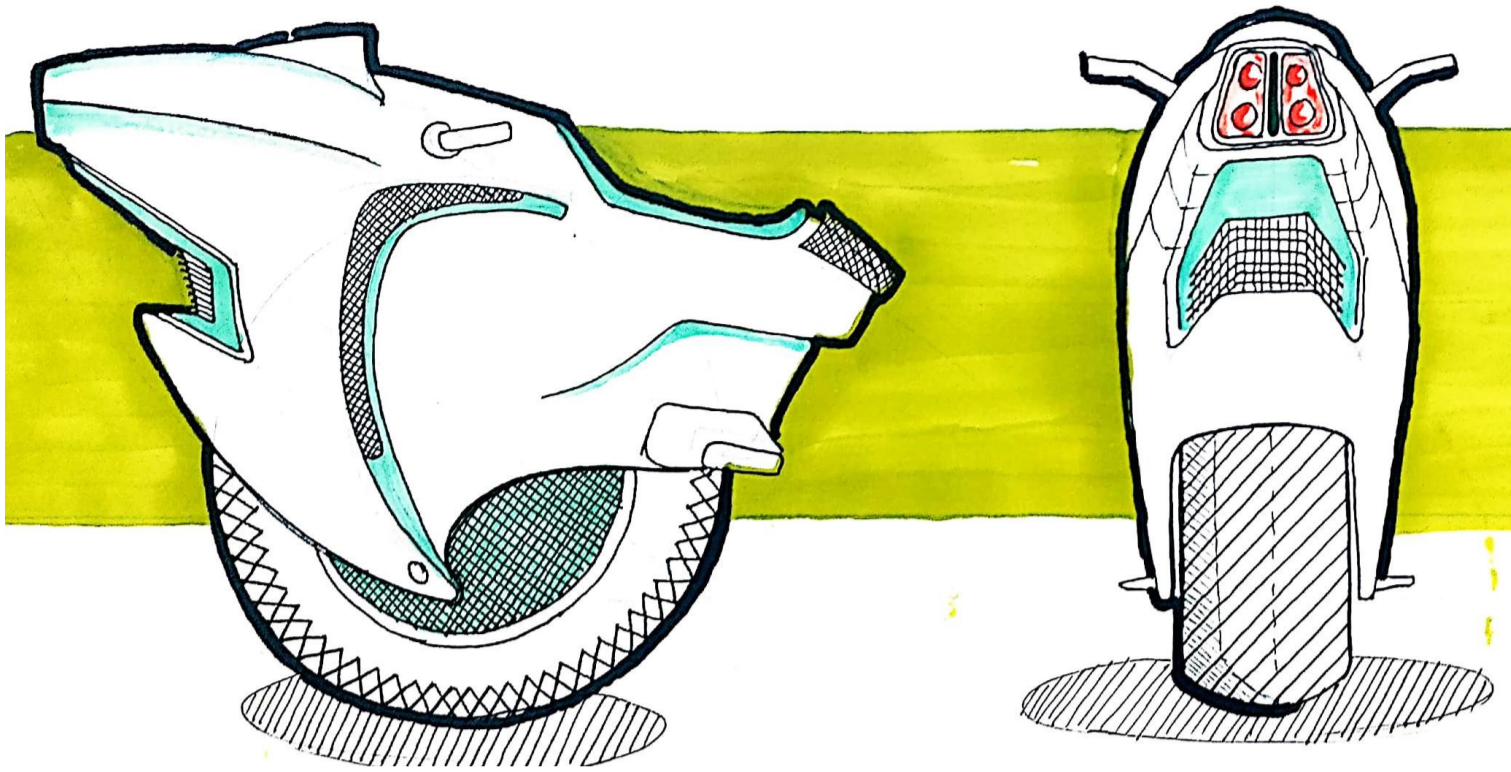

Figure 3.8 – Ideation sketch 1

Here i am exploring the dynamic form of the vehicle. Streamlined body for better aerodynamics. Wider tires give a good grip on the track. Handle and seat position is such that the rider will have a forward leaning position. Front and side grills are for the ventilation for battery. It is mostly for fast moving vehicle.

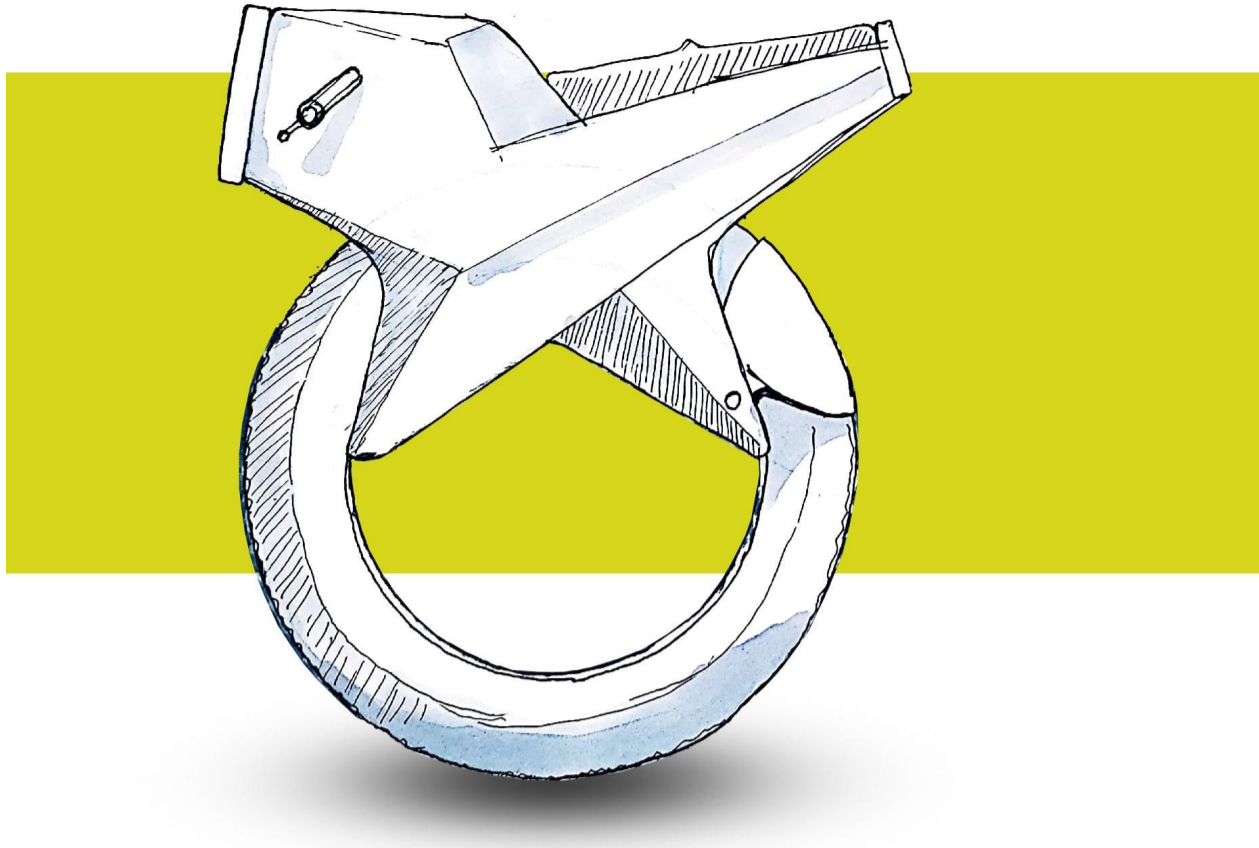

Figure 3.9 – Ideation sketch 2

Here the driving motor pushed into the body. The wheel does not have a hub. It's made to create a surprise and curiosity for the rider as well as the spectator. Edgy lines on the body made to give the look and feel of strong.

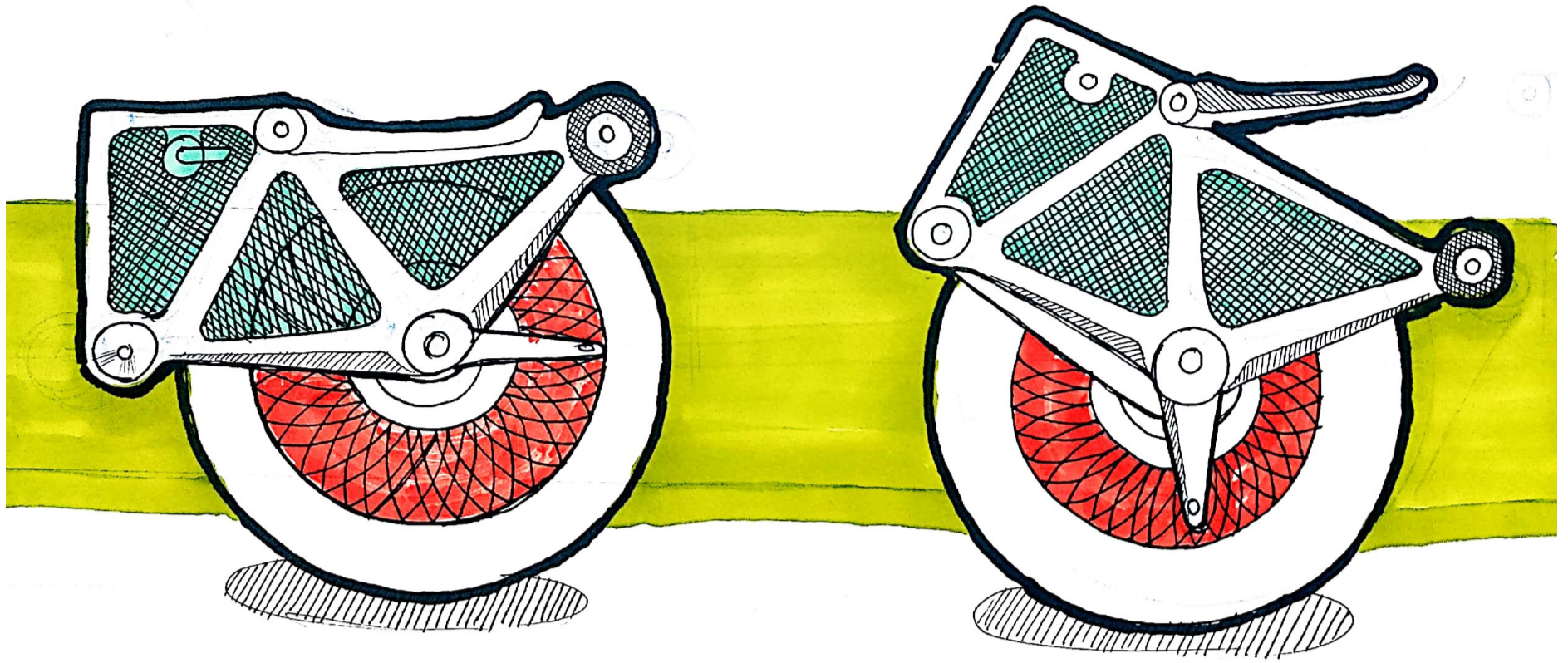

Figure 3.10 – Ideation sketch 3

Here i am trying to design the vehicle out of a rectangular block. The trellis body milled out of the aluminum composite block. The wheel is mounted on the body with swing arm suspension. This can be more potable.

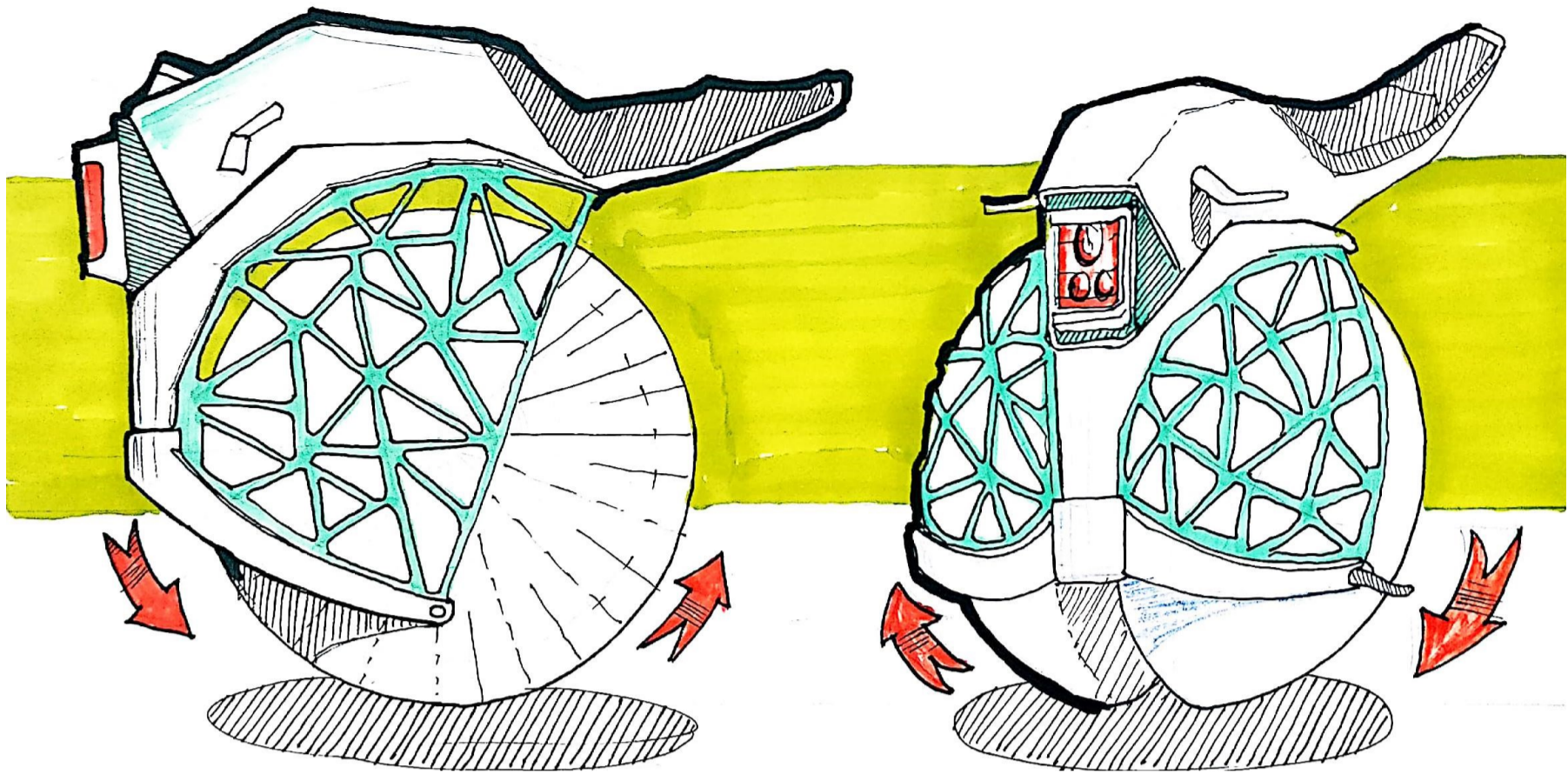

Figure 3.11 – Ideation sketch 4

Here the design contains a spherical wheel. The design is inspired from the bull ride. This can move forward as well as side wise. Here the rider will site alike a bull rider.

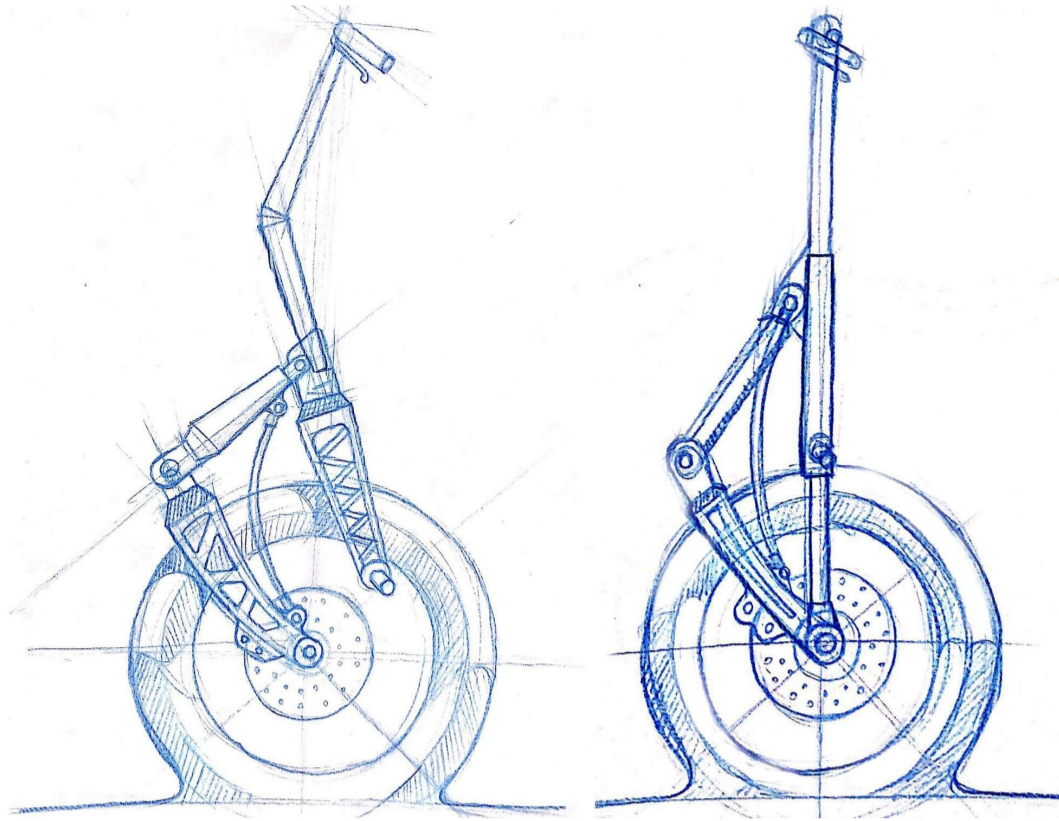

Figure 3.12 – Ideation sketch 5

Here the rider will stand on the vehicle while riding. Here the long suspension will help to take the impact of rough terrain. Long suspension travel will help the rider to jump up with the vehicle. Aluminum composite body will be lightweight and strong, it will help to perform different tricks like jumping and flipping.

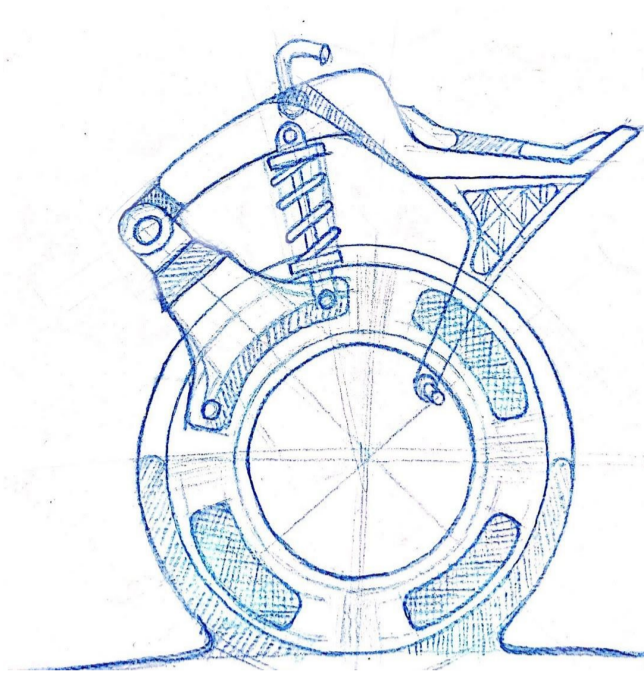

Figure 3.13 – Ideation sketch 6

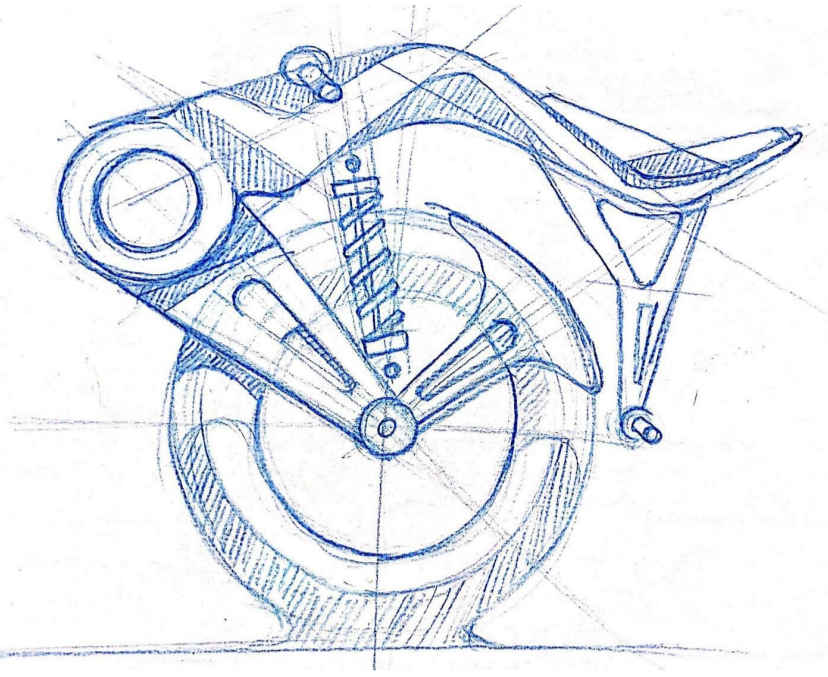

Figure 3.14 – Ideation sketch 7

Here the idea was to design a full scale electric motor bike. The rider will sit on the bike while riding. The swing arm suspension will take the impact of roads. The long suspension travel will support going off roading. The rider can also jump up and perform stunts as the monolithic body is light. Her in the Fig.-3.13 there is no hub. It has a inbuilt motor in the rim itself. The Fig.-3.14 has a bigger diameter hinge joint. It has auto close hinge spring which gives additional suspension support. Both the ideas have monolithic body construction.

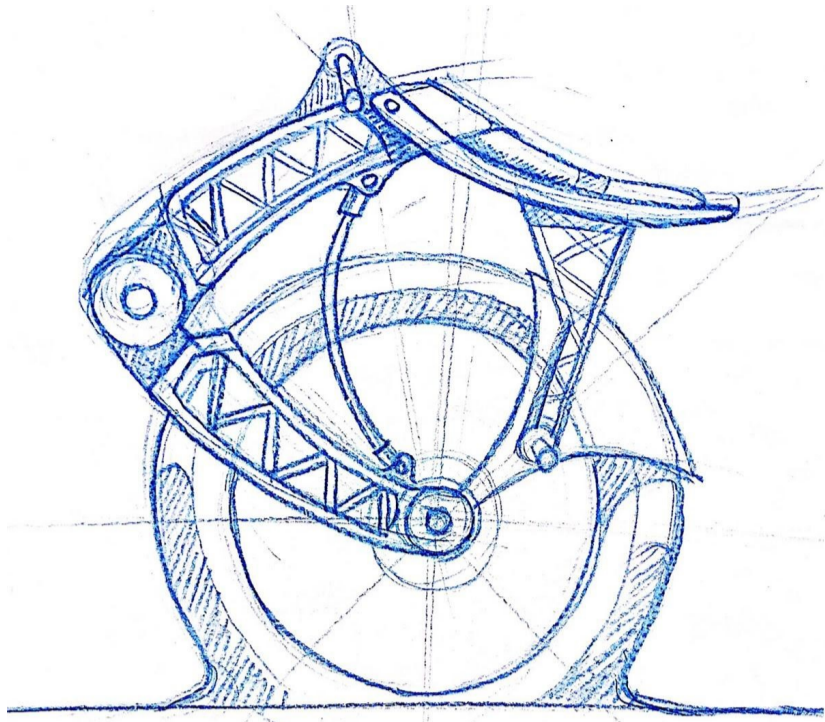

Figure 3.15 – Ideation sketch 8

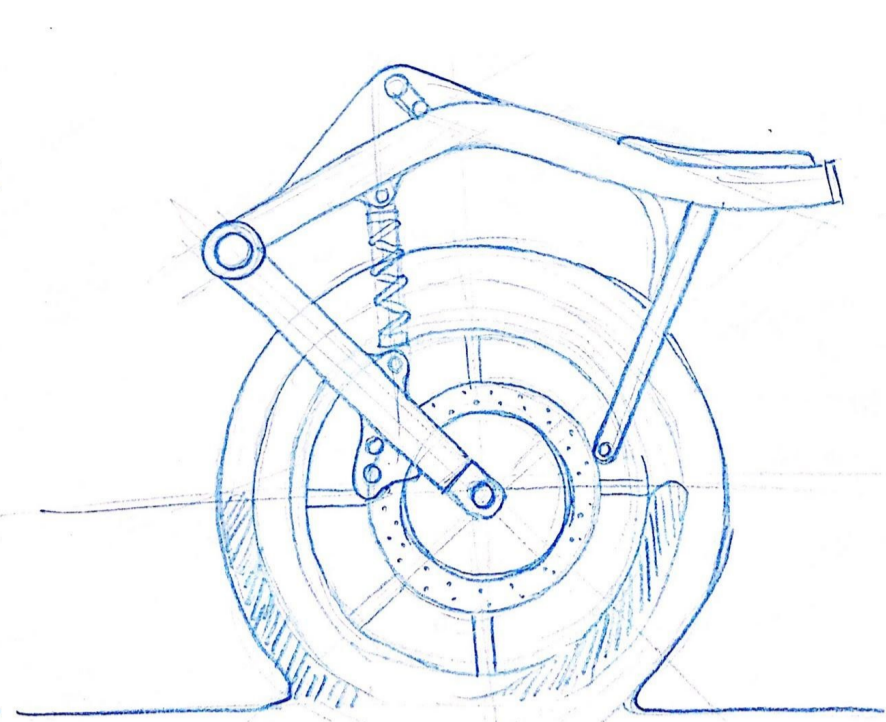

Figure 3.16 – Ideation sketch 9

Here in the Fig,-3.15 body is a trellis frame type. The body will be made of metal tubes and the truss structure gives a rugged and tough look. The running blade suspension gives sleek look to the body. The foot rest is mounted on the body to give better riding posture. In the Fig.-3.16 body is made out of single metal tubes of bigger diameter. Here the whole body is sleek, minimal, light weight. It has spring loaded suspension. It has disk brake system. Both the ideas have forward leaning seating position and low pressure tires.

3.3 Concepts

3.3.1 Concept 1

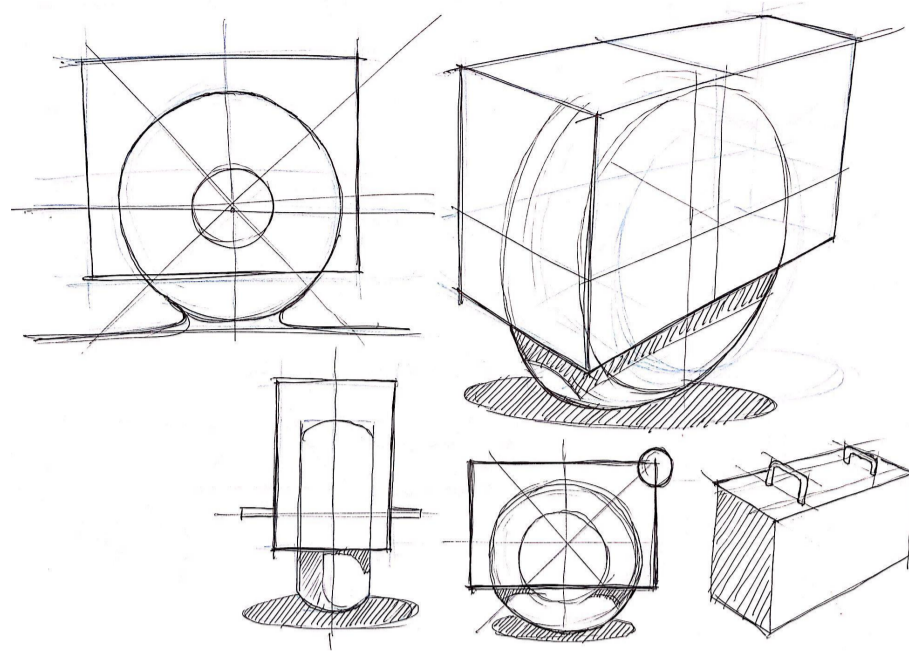

Figure 3.17 – Ideation sketch 10

Here the idea is to design a box which has all the components and can be easily transportable. This box has two roller wheels will help during carrying. It will have some grab rails. The handle will be retractable from the body. It will have a sleek and minimal body design.

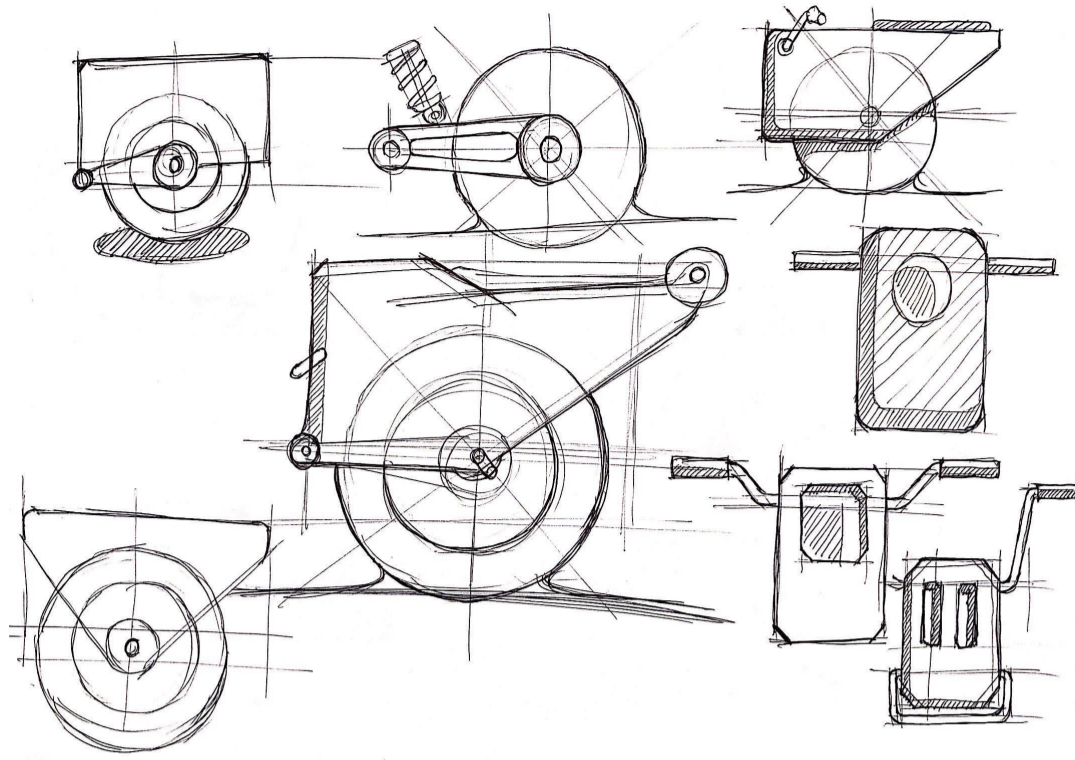

Figure 3.18 – Ideation sketch 11

Here i am using swing arm suspension. The wheel can be pushed in while storing or transporting. Here we can use chamfered edges or filleted edges depending on the look and feel we want. The filleted edged body will give a smooth look and the chamfered gives a hard or strong look. The footrest and wheel will be detached to give a right riding posture. Here we will be using mono shock

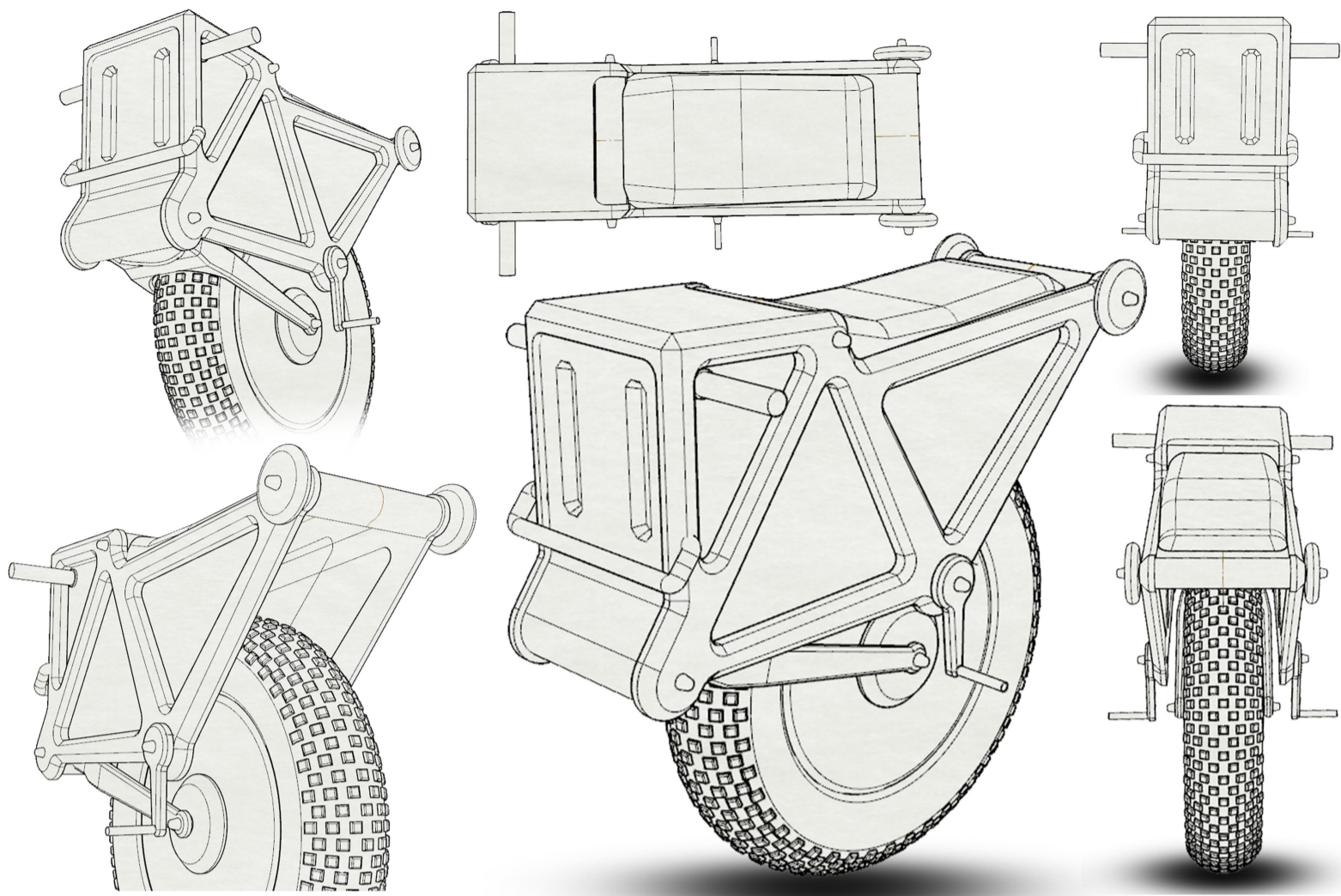

Figure 3.19 – Line drawing of the concept 1

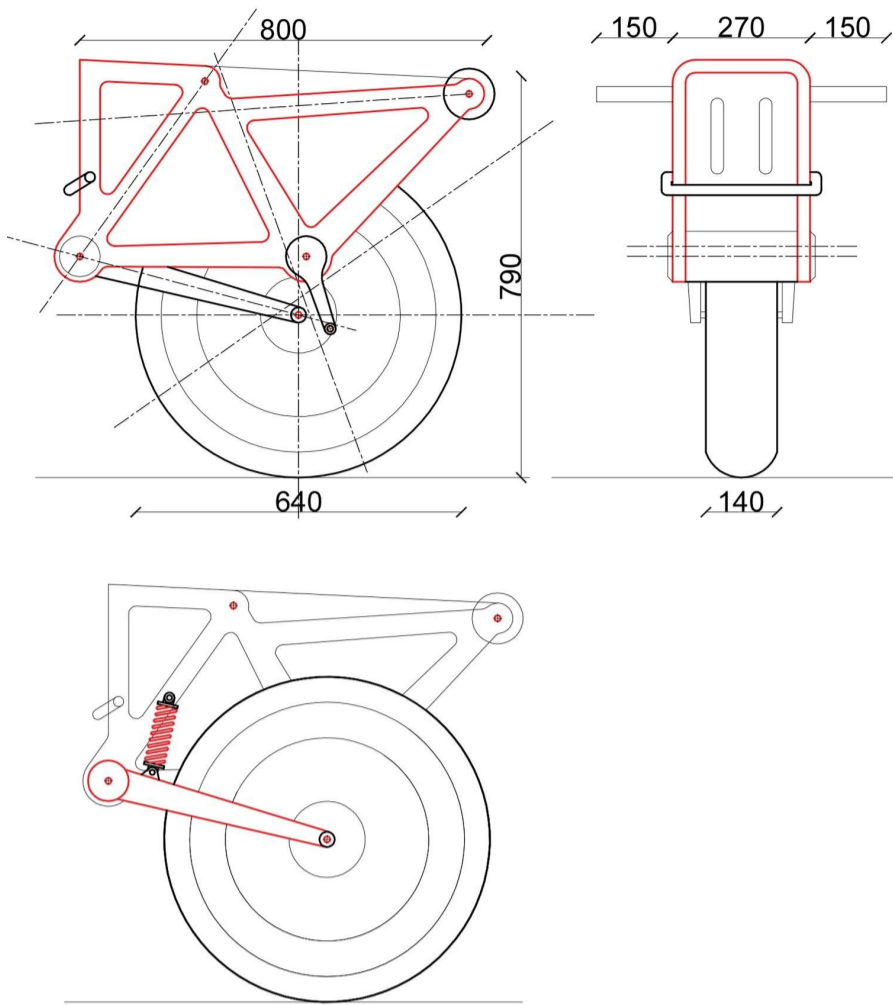

Figure 3.20 – Dimensional drawing



Figure 3.21 - 3D model



Figure 3.22 – 3D visualization of the concept

3.3.2 Concept 2

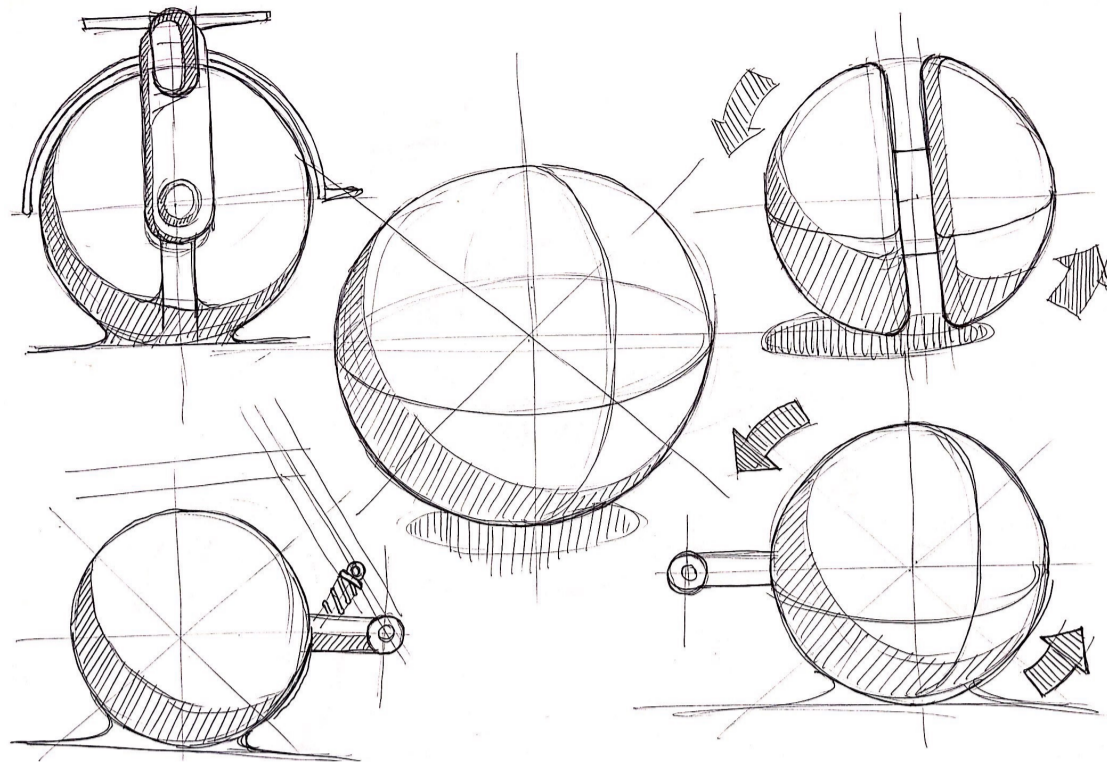

Figure 3.23 – Ideation sketch 13

Here i am using a spherical wheel to explore the disruptive movements of the vehicle. It will have two hemispherical wheel part mounted to a hub. It will have a swing arm suspension. The swing arm will be mounted to the body with another hub motor. These two hub motors can be stopped or activated depending on the movement rider wants. Here the idea is to create a unique riding experience.

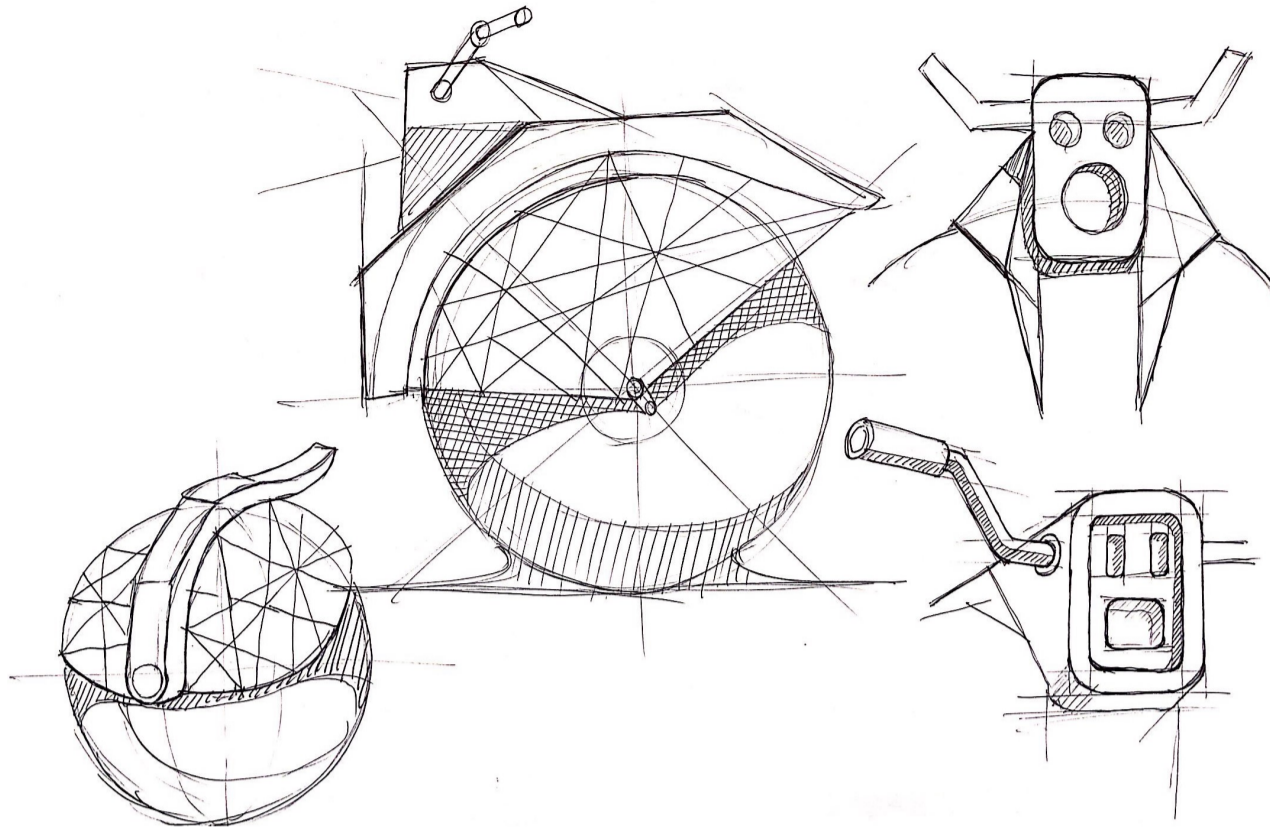

Figure 3.24 – Ideation sketch 14

Here the rider's body posture will be as riding a bull. The body is wide and bulky. The leg rest position will be wider than usual rides. The head light can be derived from the face of a bull.

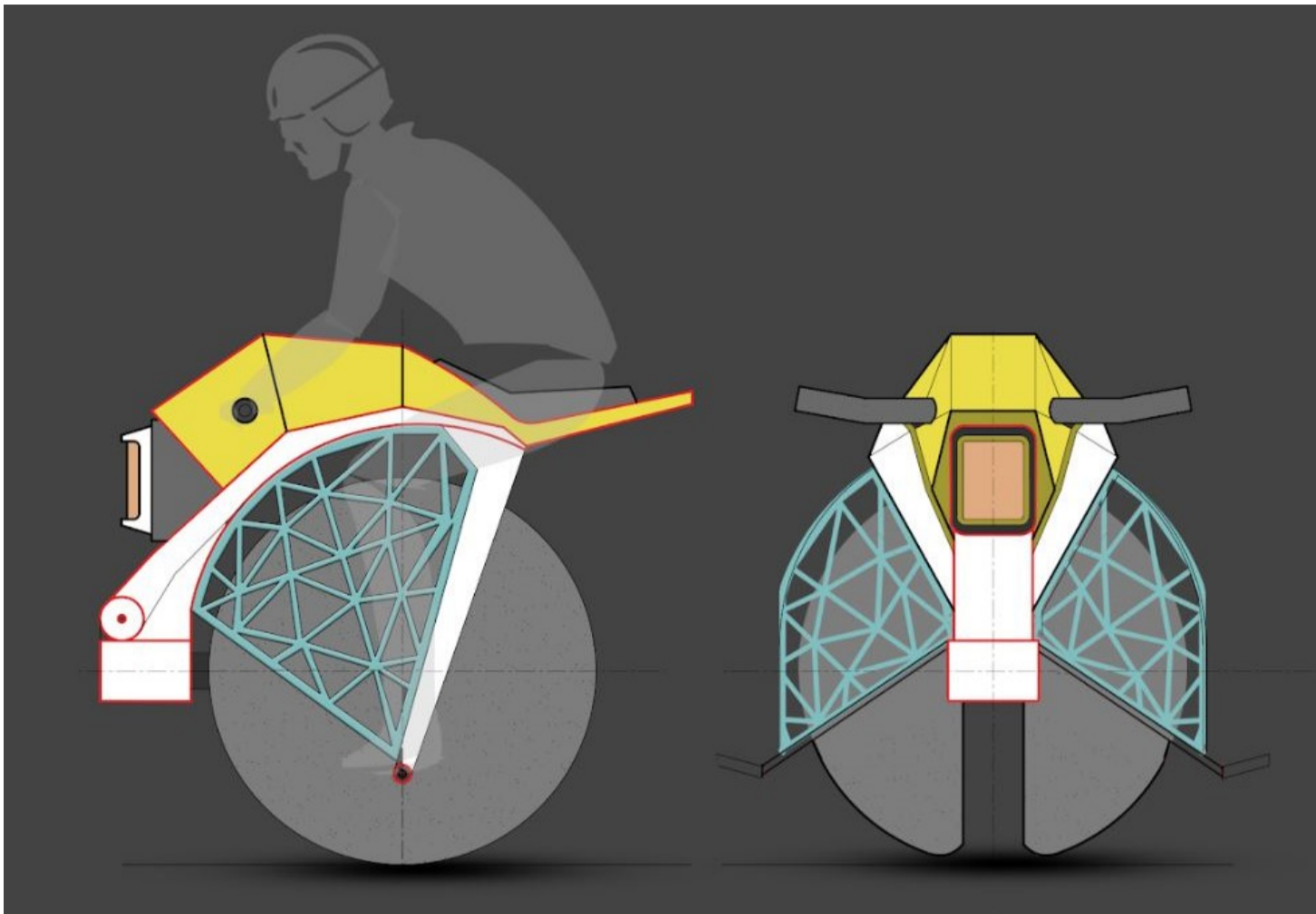

Figure 3.25 – 2D render of the concept 2

3.3.3 Concept 3

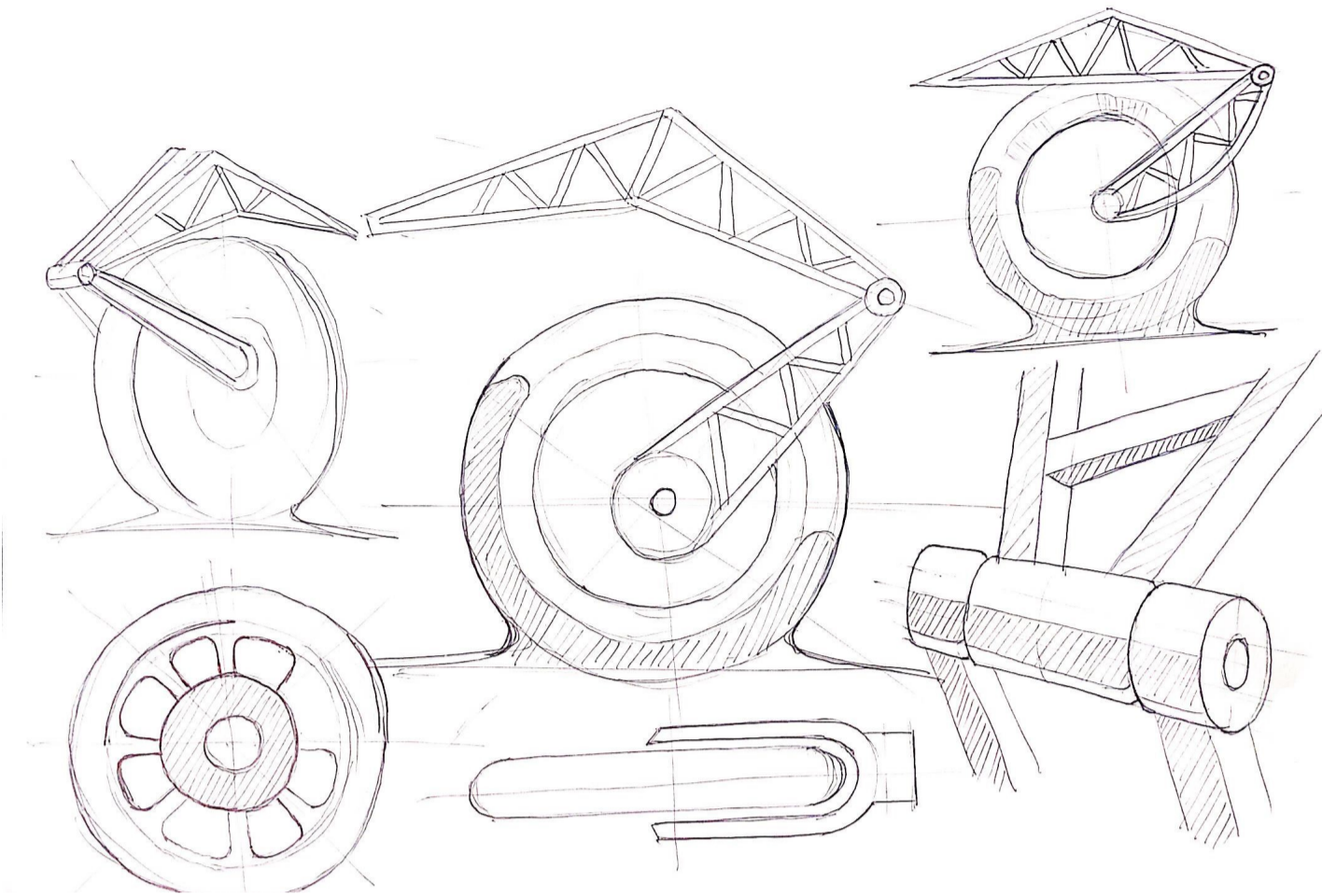

Figure 3.26 – Ideation sketch 15

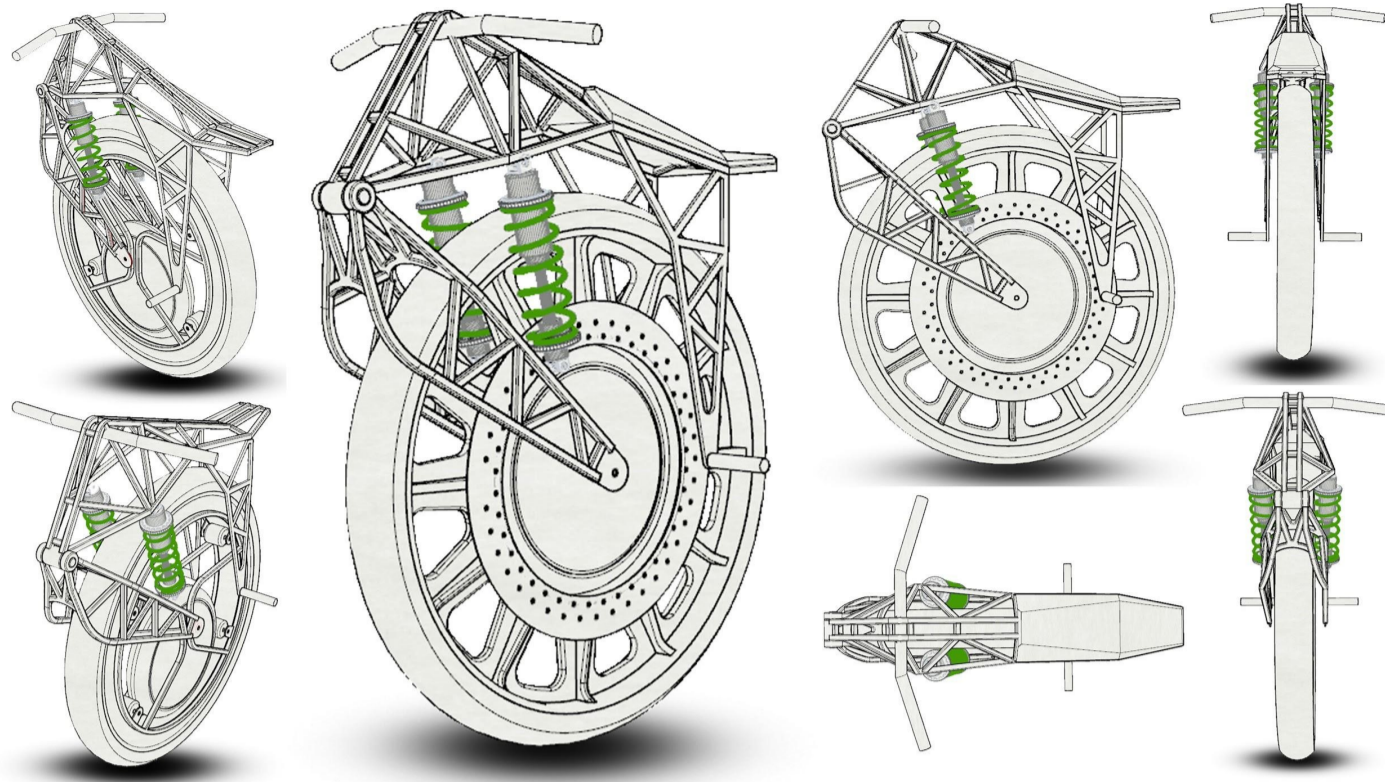

Figure 3.27 – Line drawings of the concept 3

Here the idea is to create a sleek trellis frame. The wheel battery and the processor can be fit into it easily. The trellis frame will be made out of 12mm square metal hollow section. Swing arm suspension will be used here. The swing arm will be placed 45° to horizontal plane. Here two shock absorbers are used.

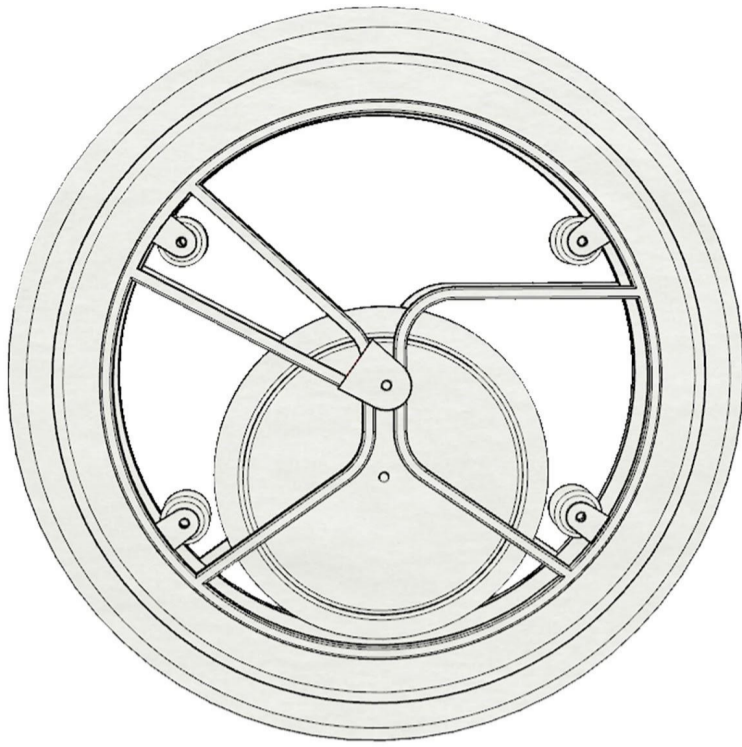

Figure 3.28 – Line drawing of hub 1

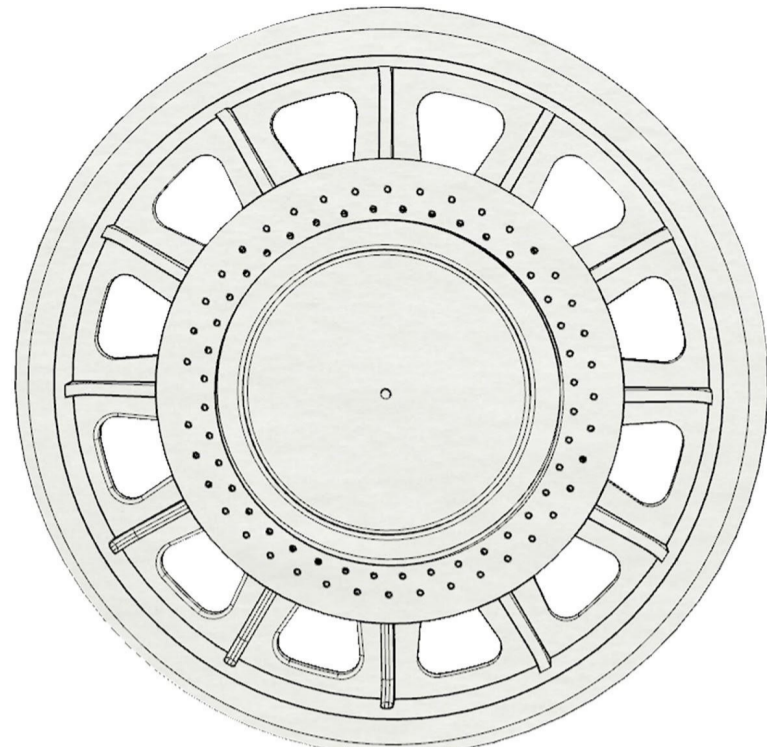

Figure 3.29 – Line drawing of hub 2

There are two types of the hub assembly proposed here. The first one Fig.-3.28 has motor mounted down, off center to the main wheel. There are rollers placed on the rim. A frame is holding motor and roller. This motor drives the wheel and rollers help the wheel to be in line as a guide. But in Fig.-3.29 the hub motor is mounted in the center. It holds the rim. The wheel has disc brake system also. It is comparatively simple.

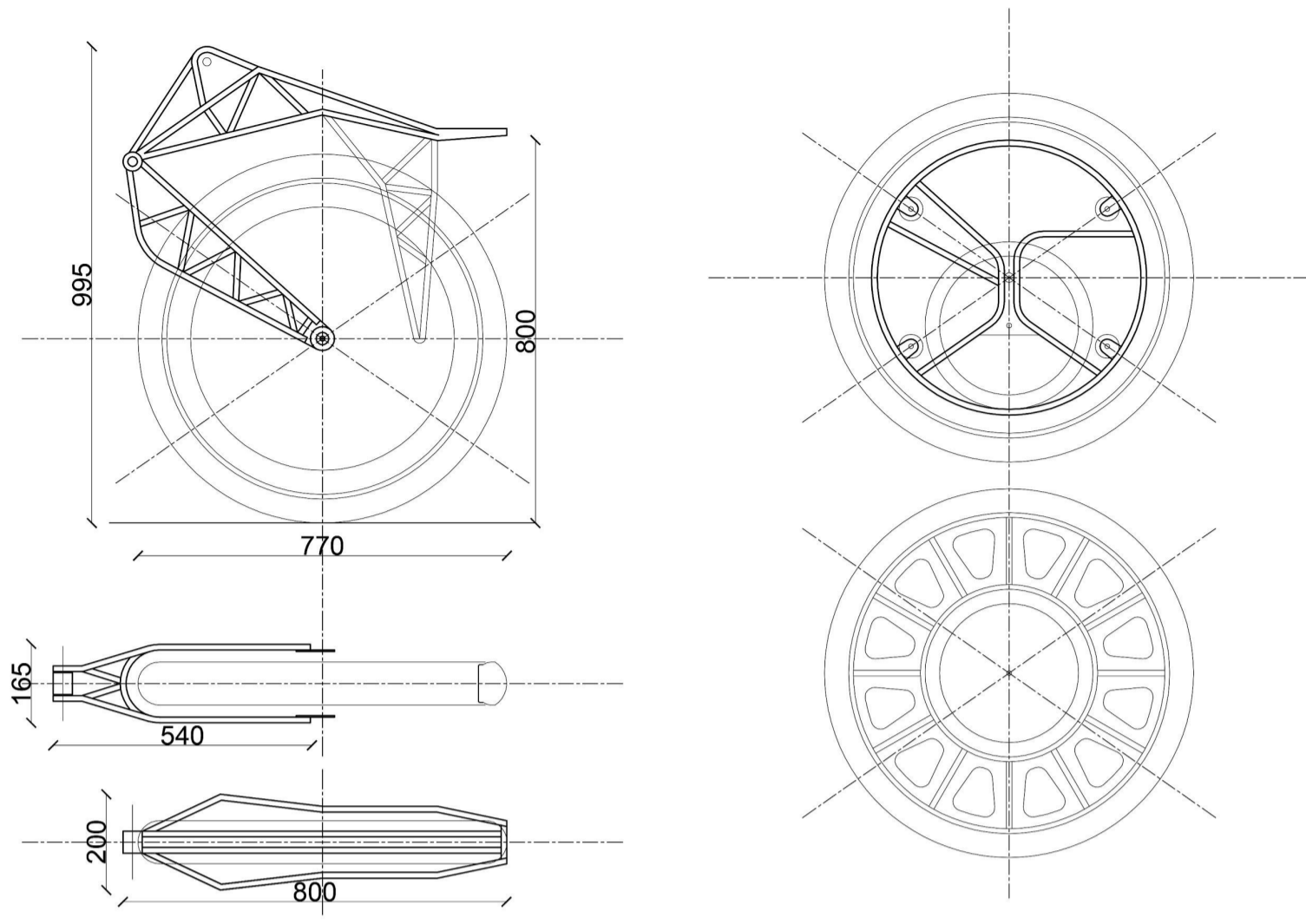

Figure 3.30 – Dimensional drawings of the concept

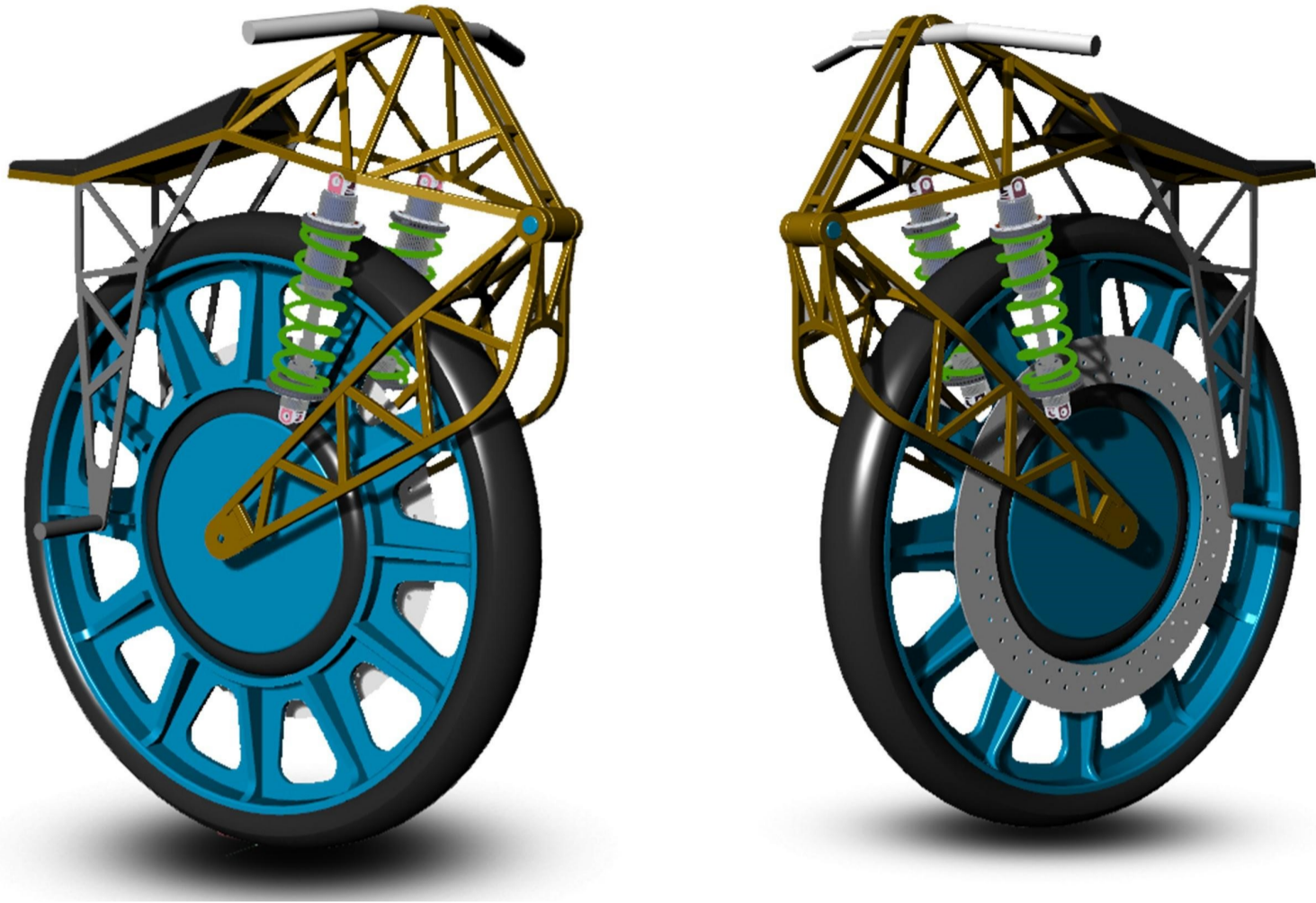

Figure 3.31 – 3D visualization of the concept
3.3.4 Concept 4

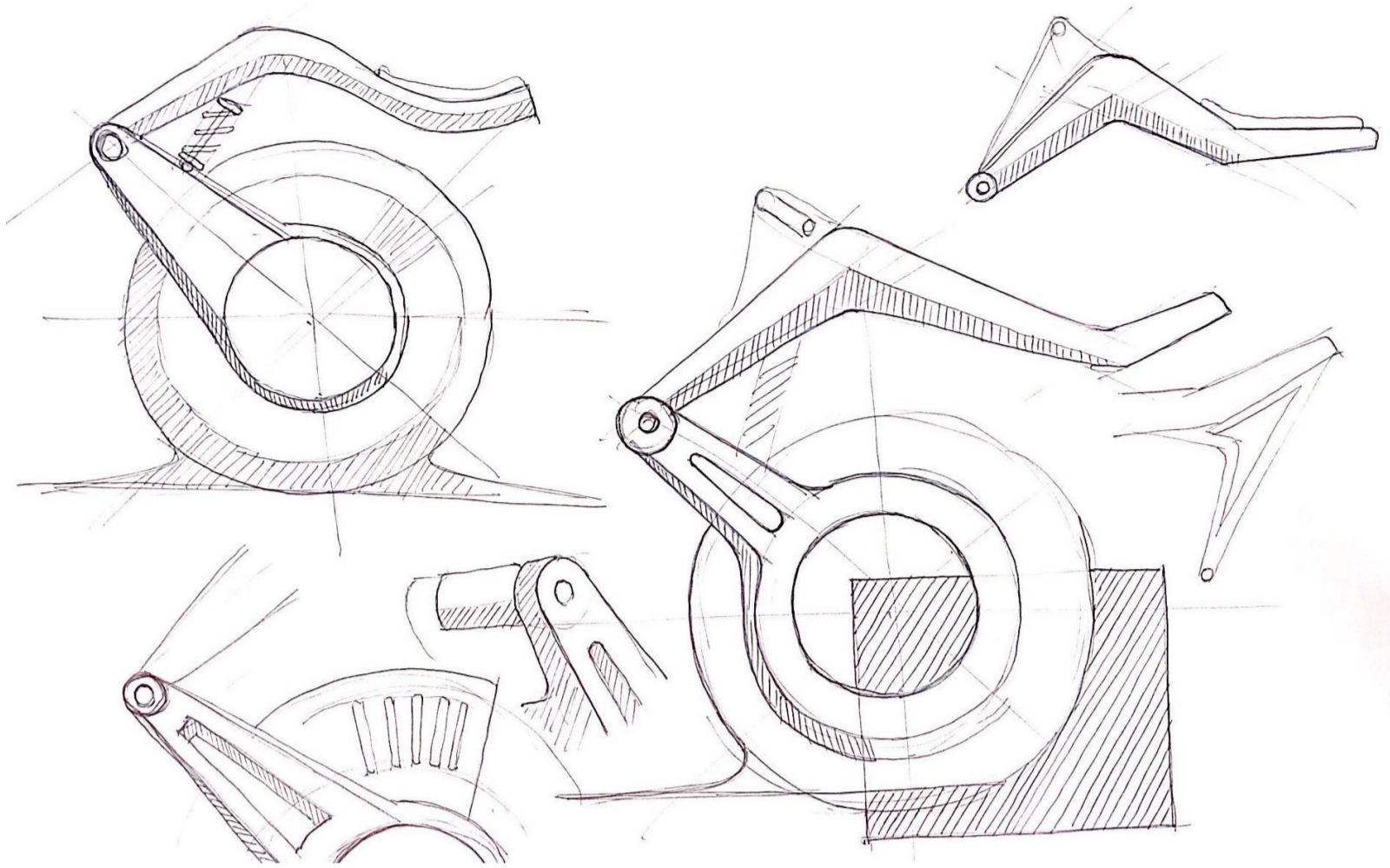

Figure 3.32 – Ideation sketch 16

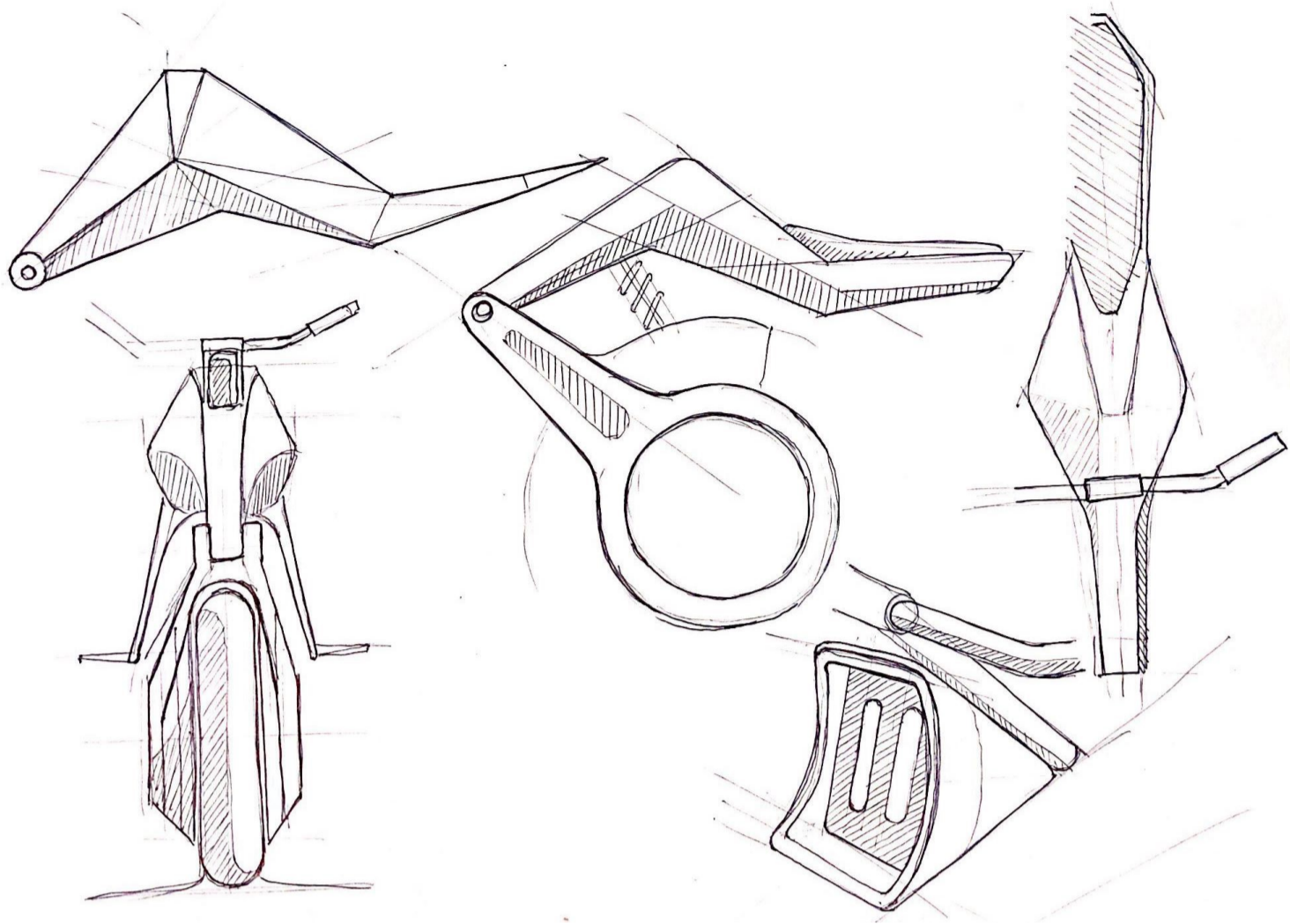

Figure 3.33 – Ideation sketch 17

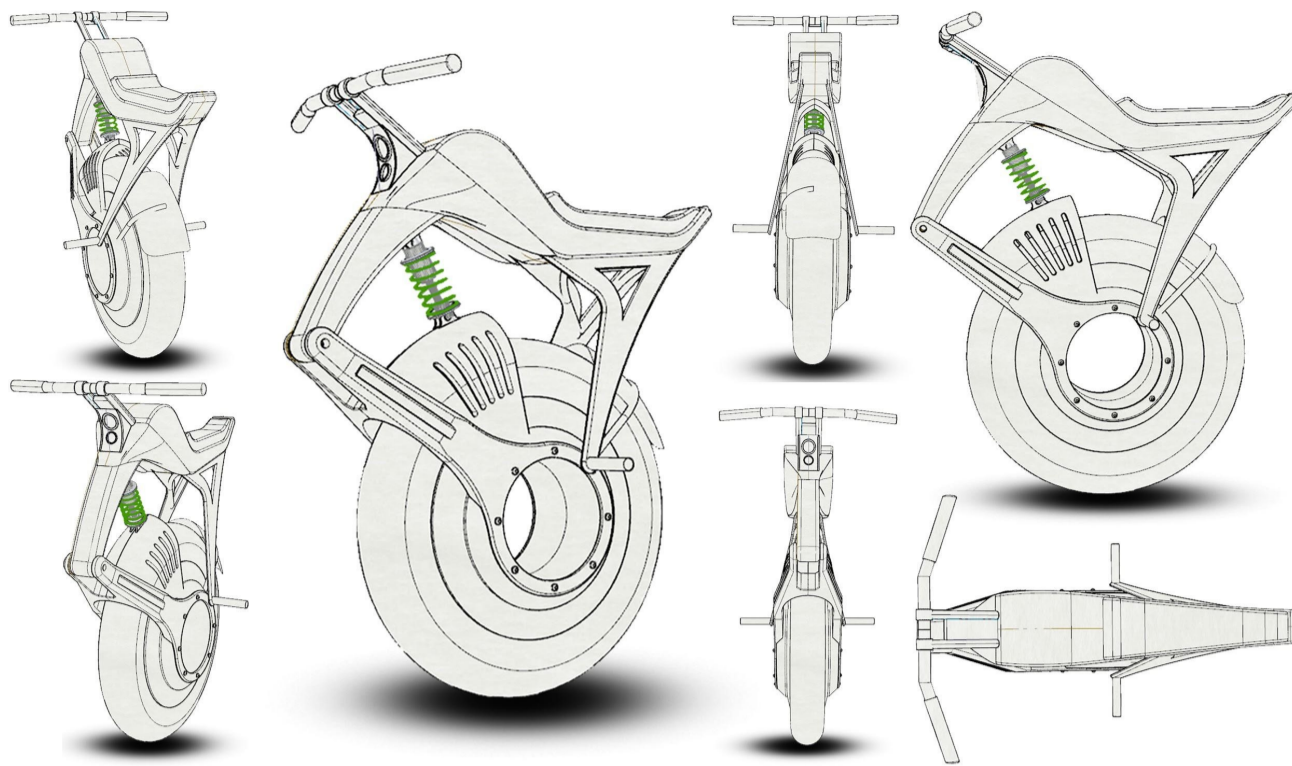

Figure 3.34 – Line drawing of the concept 4

Here the idea is to make a hubless wheel. The body is sleek, minimal to reduce the weight. The body alignment is little forward leaning to create the dynamic body. The seat, handle and footrest positioned as the forward leaning rider's triangle. The body is made sleek that the riders foot can be floored easily. The battery and processor is mounted inside the body. The swing arm suspension has mono shock with a bigger suspension travel. It helps in jumping or performing some stunt.

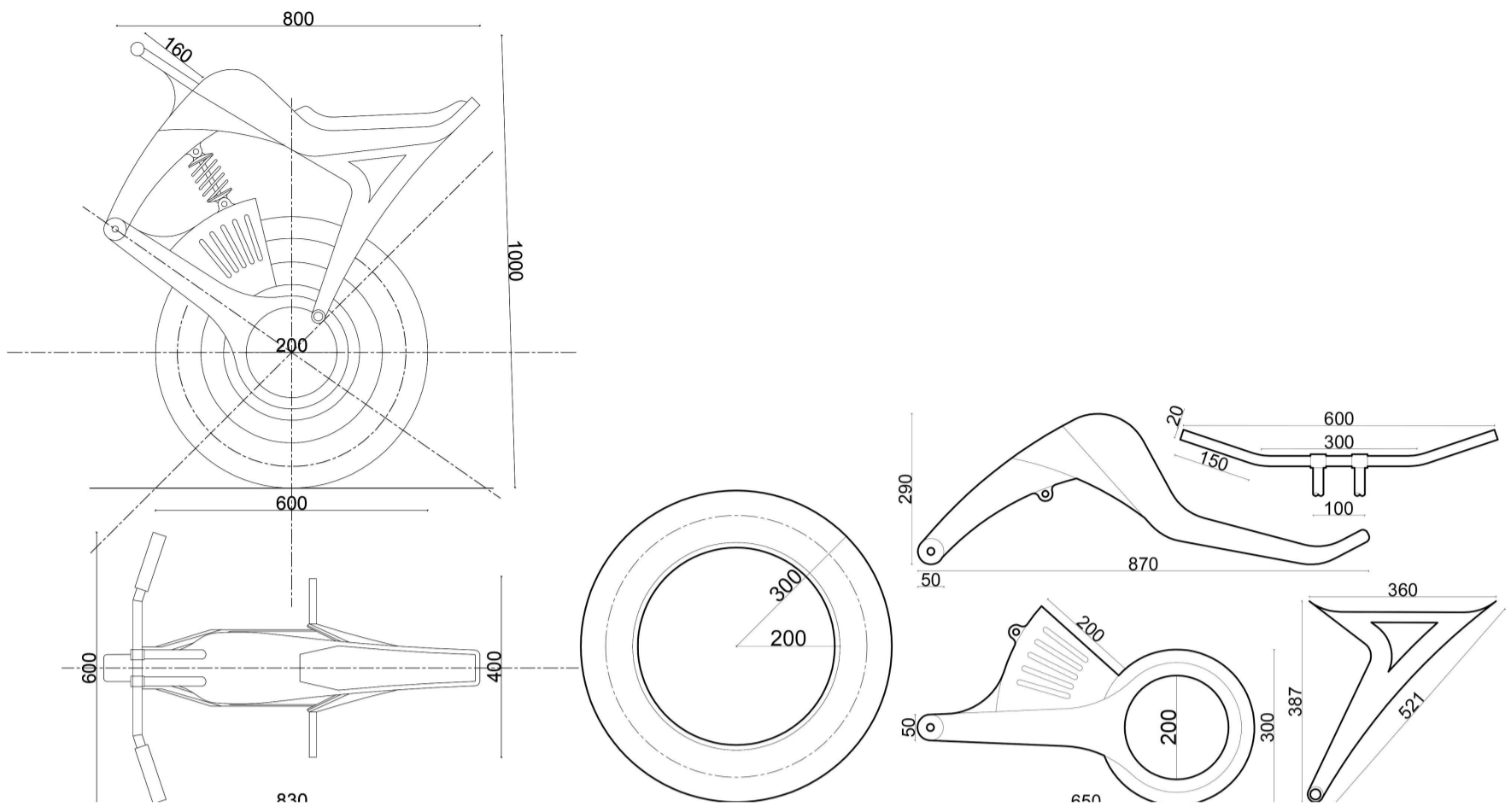

Figure 3.35 – Dimensional drawings of concept 4

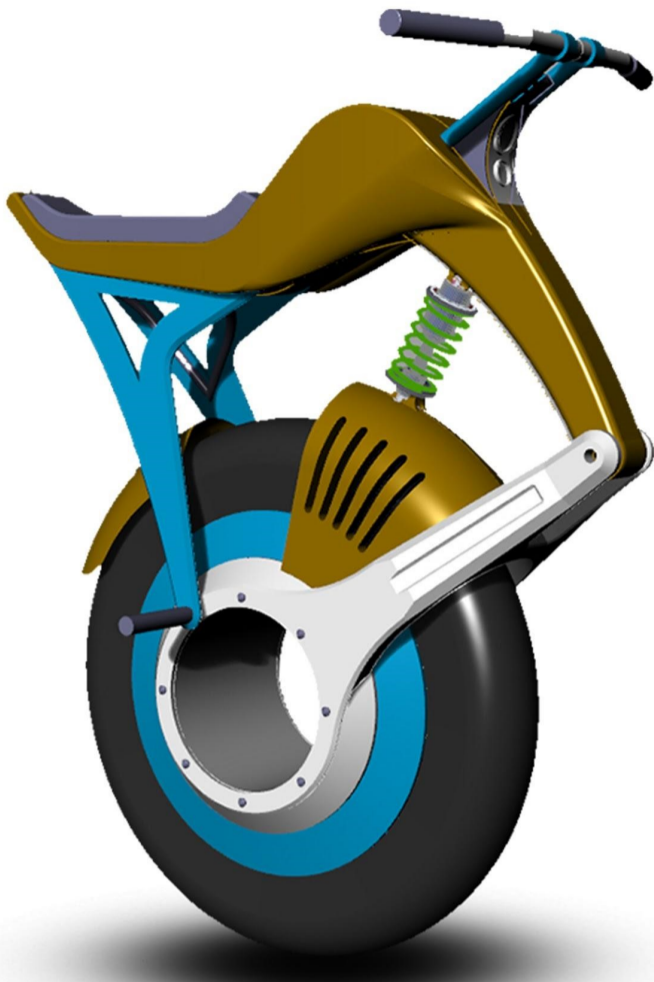

Figure 3.36 – 3D visualization of the concept 4

3.3.5 Concept 5

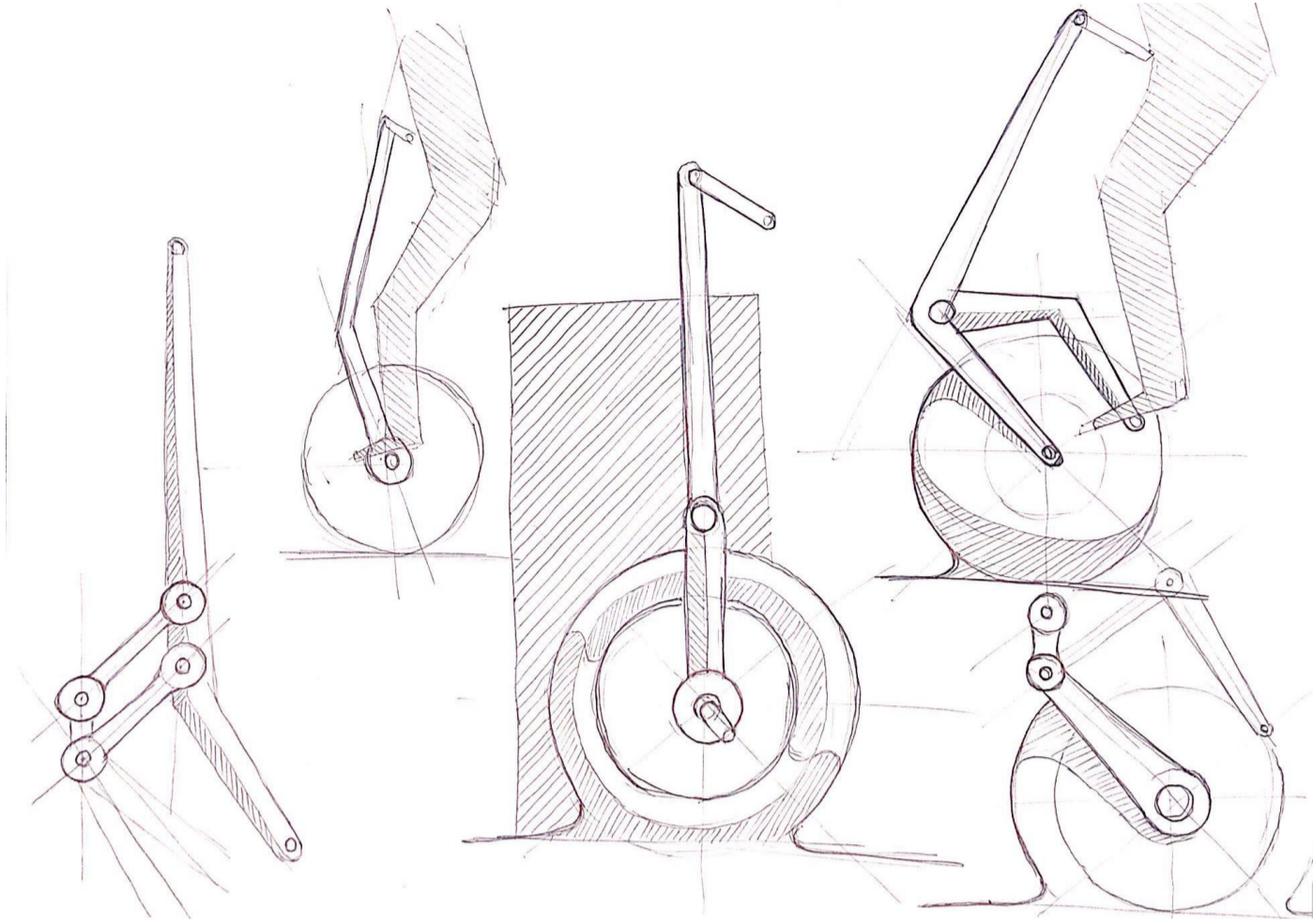

Figure 3.37 – Ideation sketch 18

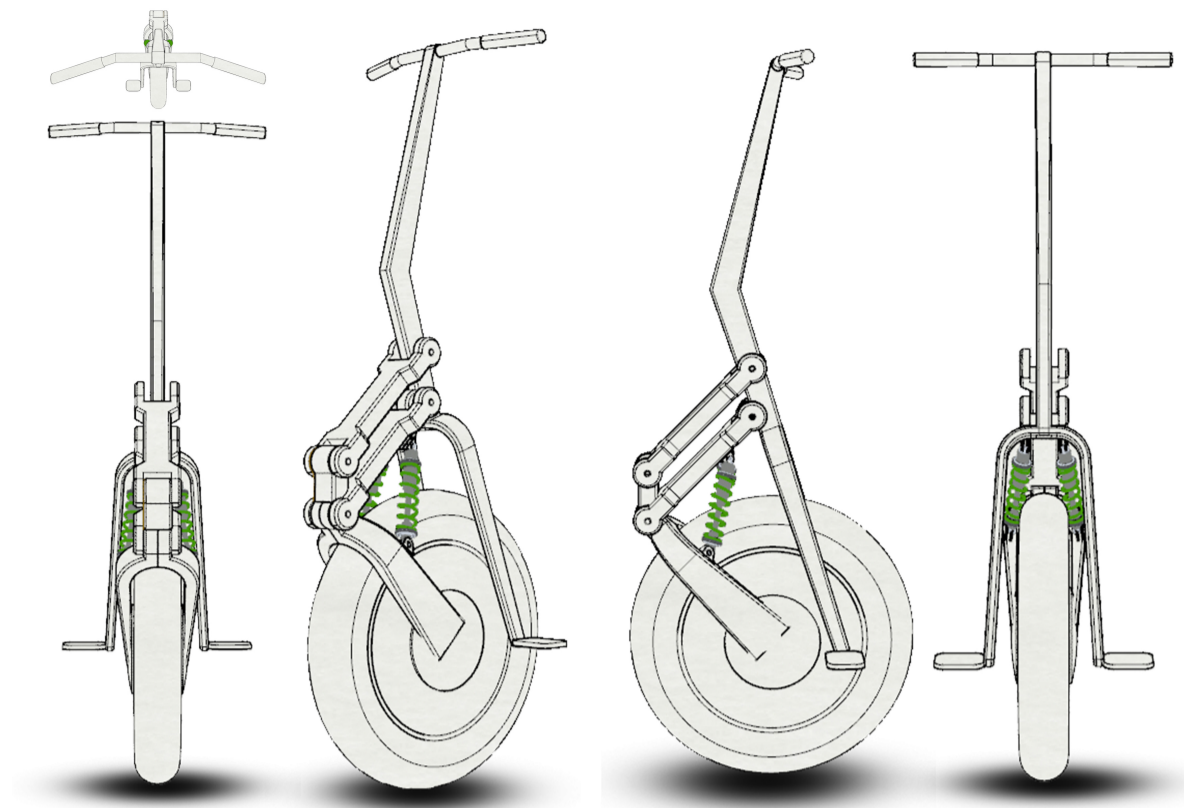

Figure 3.38 – Line drawings of the concept 5

Here the idea is to ride the vehicle with standing posture. There are two wide foot rests to stand on it. The body is connected to wheel with a swing arm suspension system. The swing arm is supported by two spring loaded shock absorber mounted on either side of the vehicle. This has minimal and sleek body. Here the rider can move forward, jump, stunt, etc.

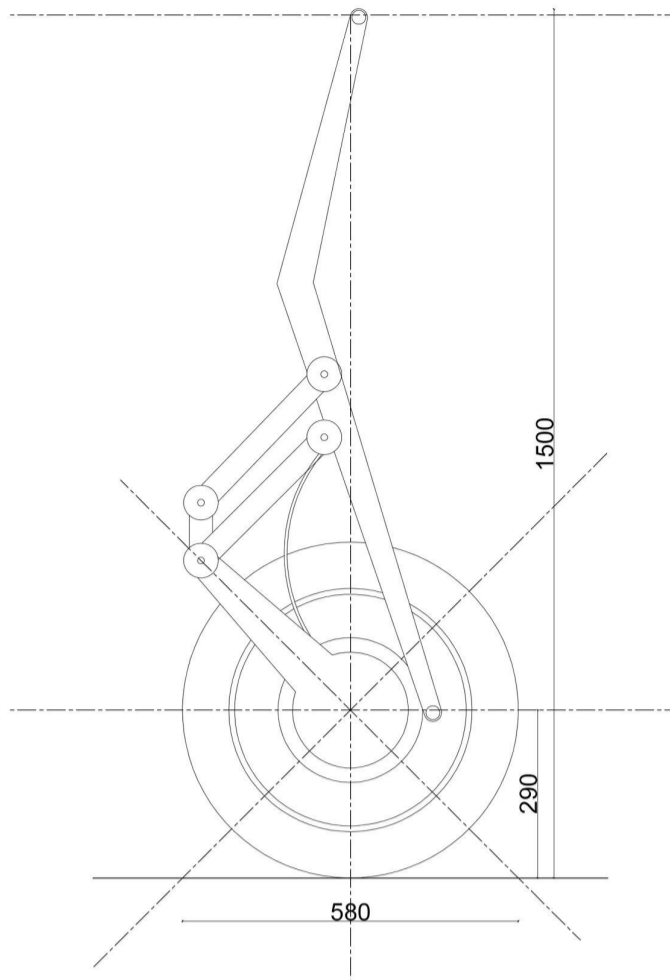

Figure 3.39 – Dimensional drawing of the concept 5



Figure 3.40 – 3D visualization of the concept 5



Figure 3.41 – 3D visualization of the concept 5

3.4 Concept evaluation

Here i did a concept evaluation based on the criteria like Driving dexterity, Comfort, Aesthetics, Complexity and Manufacturability. I showed the concepts to my friends and told them to grade the design based on above criteria from 5.

Driving dexterity: It's the ease in driving. How the body posture comes out of the design. The ease in controlling the ride on the track.

Comfort: It's the comfort during the ride.

Aesthetic: It's the styling of the vehicle. How good it communicates its time and function.

Complexity: It's the assembly of different components. More complex components used is more cost.

Manufacturability: It's the ease of making the prototype. It depends on the product, how simple and minimal the design is. More complex designs take more time and effort to make.

	Concept 1	Concept 2	Concept 3	Concept 4	Concept 5
--	-----------	-----------	-----------	-----------	-----------

Driving Dexterity	4	5	4	4	3
Comfort	3	2	3	3	2
Aesthetics	3	4	4	4	2
Cost	3	2	2	4	5
Manufacturability	3	2	2	3	4
Total Score	16	15	15	18	16

3.5 Bike specification

Motor: 48 V 3 kW

Power: 3000 watts

Speed: 30 km/hr

Torque: 45 n/m

Range: 40 km / charge

Battery: 48 V 100 AH

Overall Length x Width x Height: 800x500x1000 mm

Vehicle Weight: 35 Kilograms

Frame Type: Trellis frame

Tire Size: 100/80 R16

Suspension: Spring loaded Dual shock

3.6 Materials used

Frame – Galvanized steel

Breaking disk- Grey iron

Seat- PU Foam and leatherette

Body fairings- ABS

3.7 Mockups

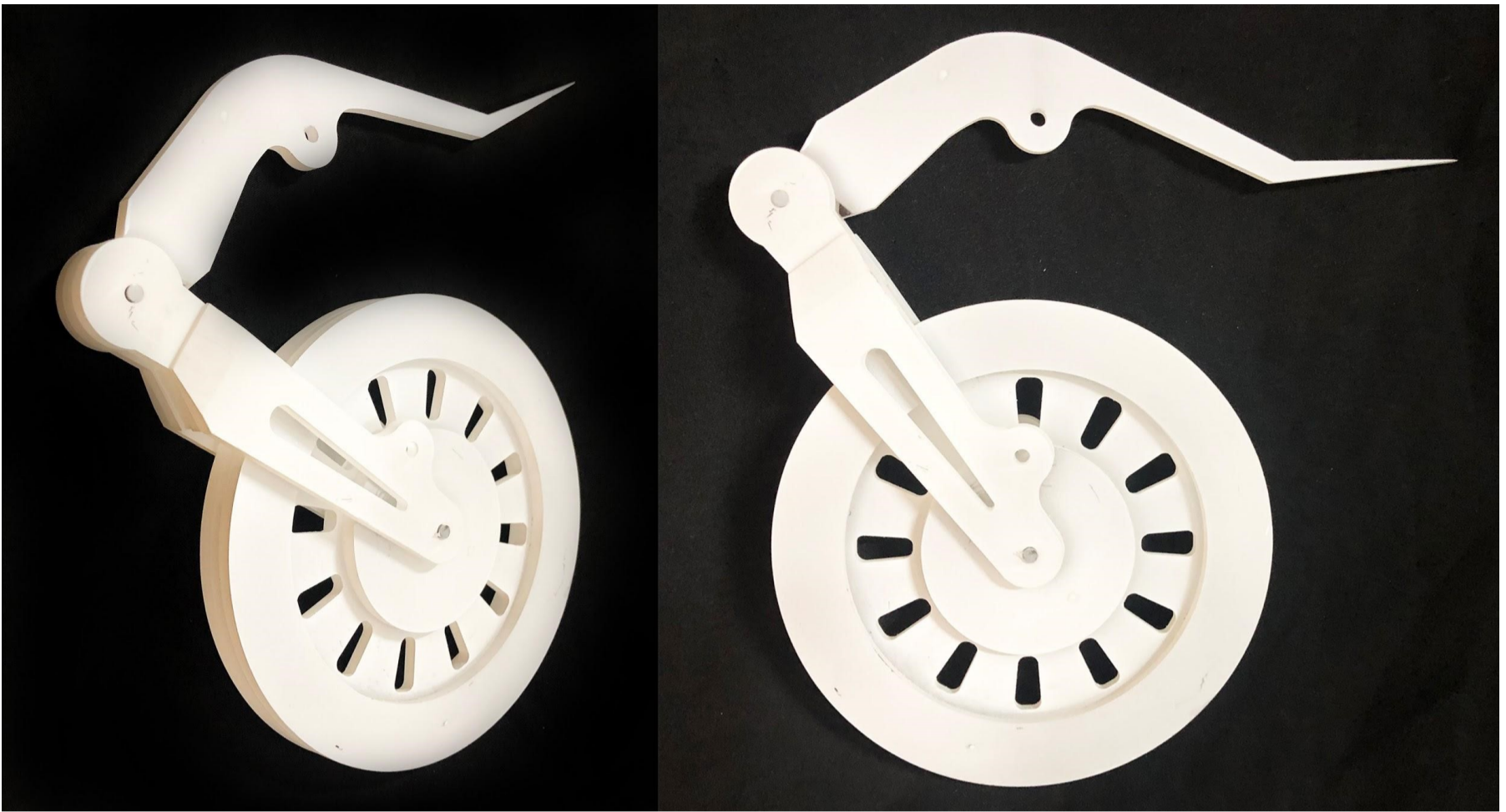

Figure 3.42 – scale model of the concept

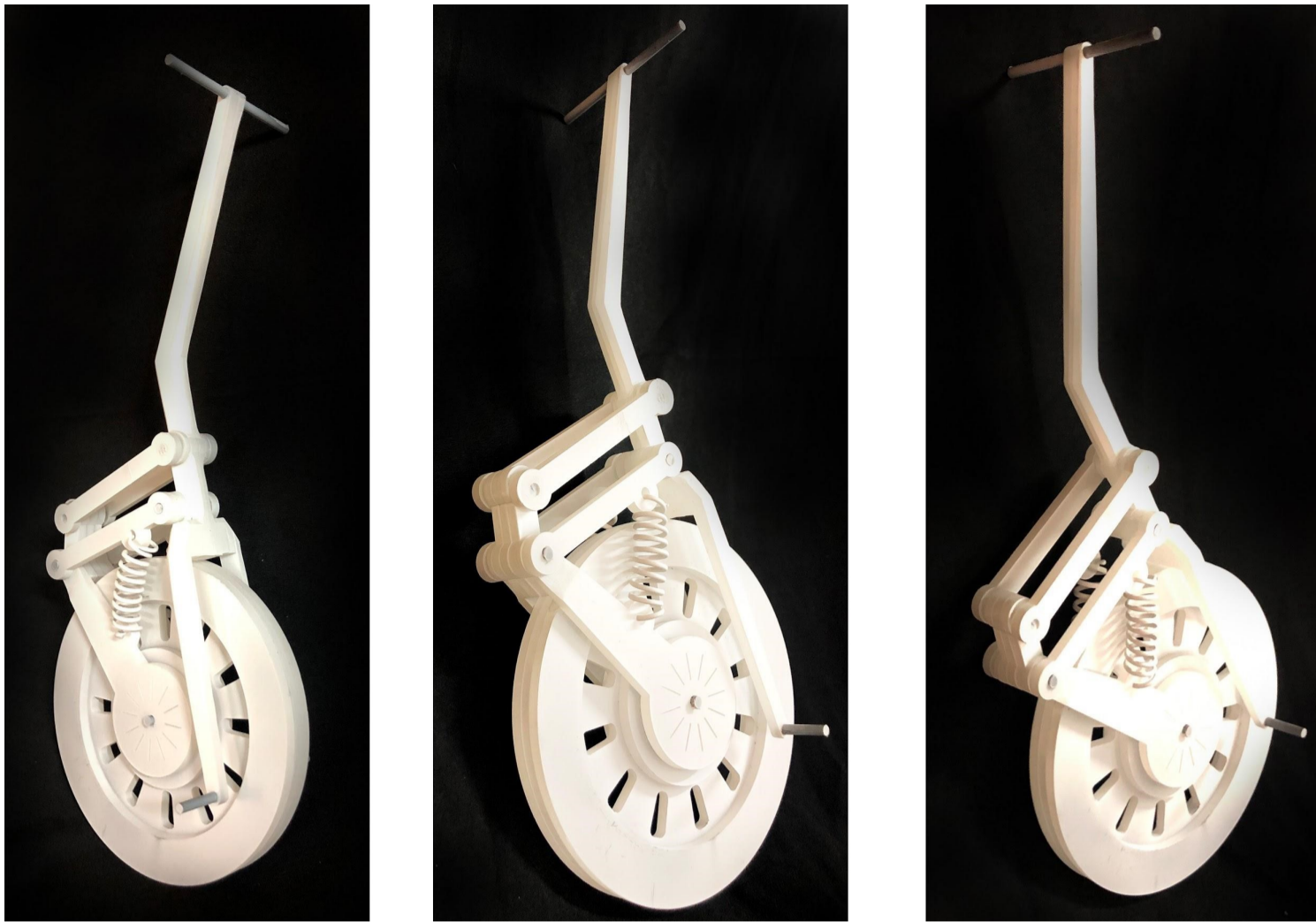

Figure 3.43 – Scale model of the concept 5



Figure 3.44 – Scale model of the concept 4

3.8 Prototyping of POC

3.8.1 POC 1

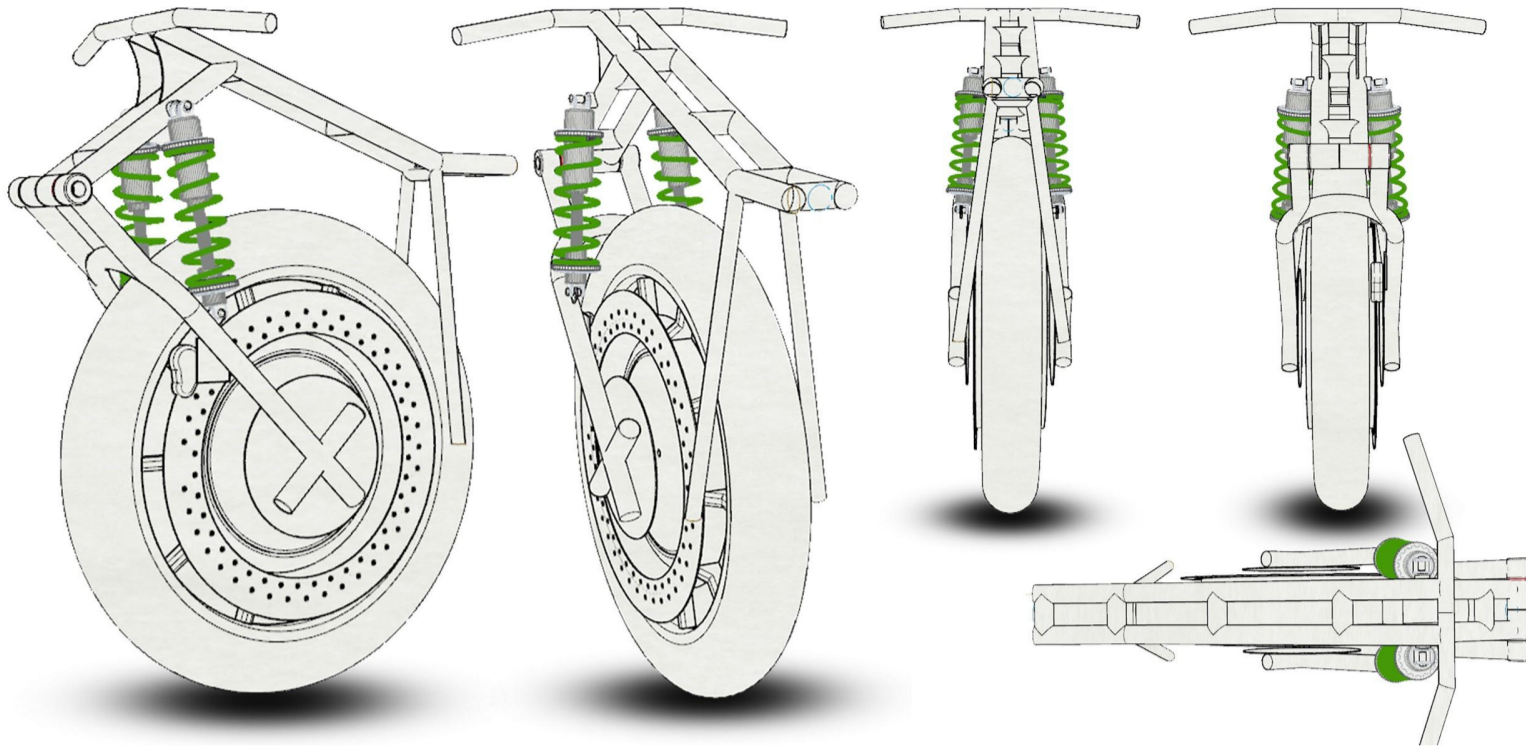

Figure 3.45 – Line drawing of the POC 1

The idea is to make the POC using 40 mm diameter GI hollow section. Swing arm 45° to horizontal plane. Swing arm is supported by simple spring loaded shock absorbers. Here I am using 675mm rim diameter. Tire is 100 mm diameter fat bike tire. It has 600mm diameter disc brake.

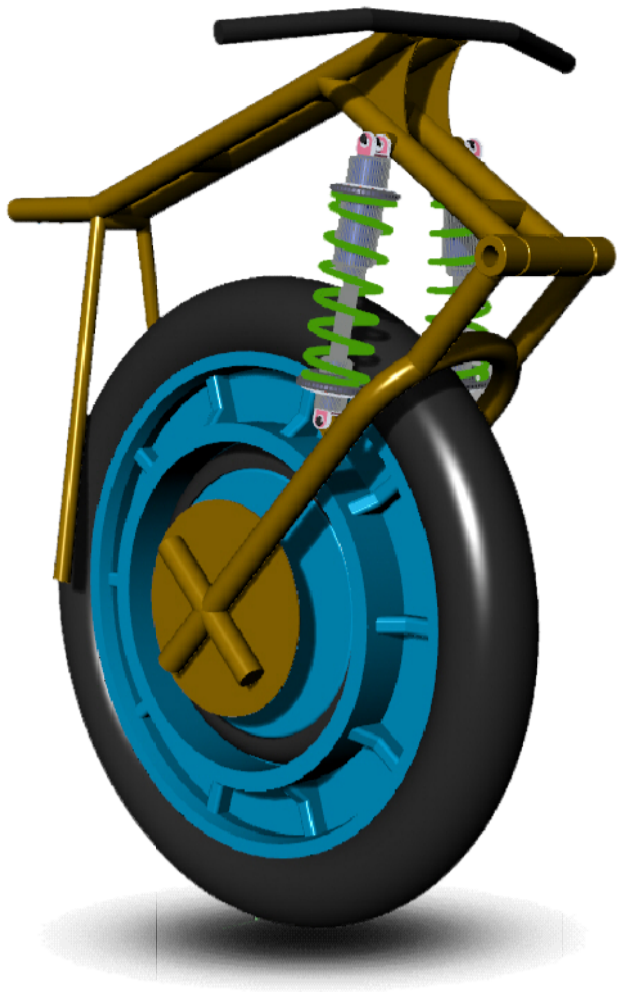

Figure 3.46 – 3D visualization of the POC 1

3.8.2 POC 2

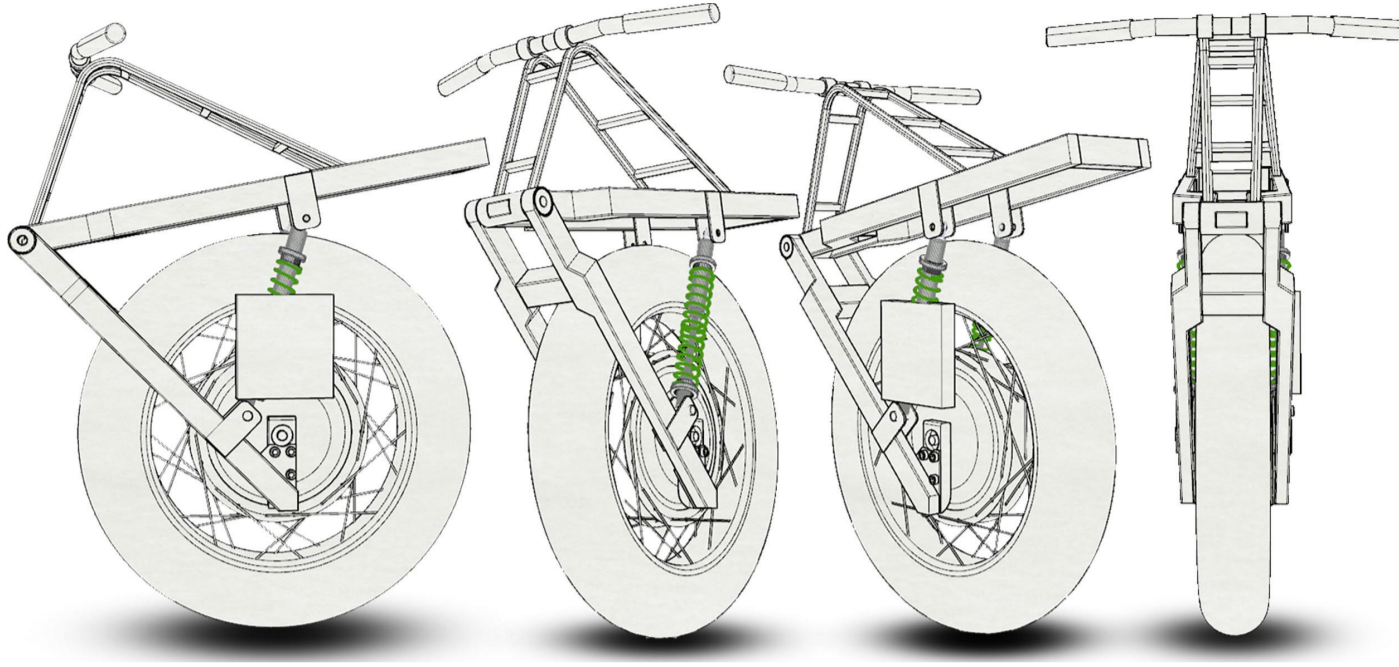

Figure 3.47 – Line drawing of the POC 2

The idea is to make the POC using 40mm X 20mm rectangular GI hollow section. Swing arm 45° to horizontal plane. Swing arm is supported by simple spring loaded shock absorbers. Here I am using 675mm rim diameter. Tire is 100 mm diameter fat bike tire. The battery and processor is mounted to the wheel on either side of the vehicle. The body is made out of two straight frames. The triangular frame on the body is made out of 12mm square hollow section. It's made to mount the handle in appropriate position as rider's triangle.

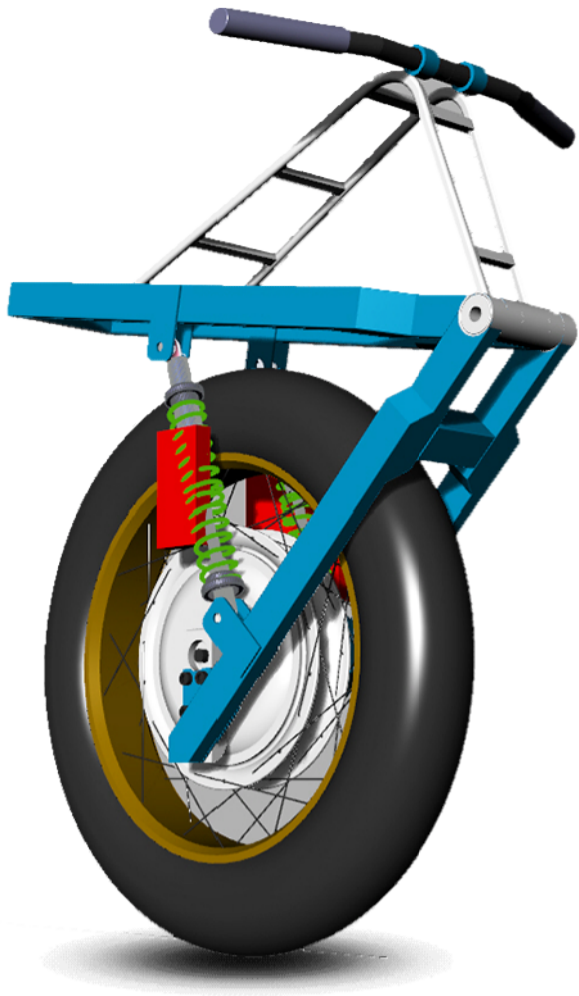

Figure 3.48 – 3D visualization of the POC 2

3.8.2 Making of working prototype

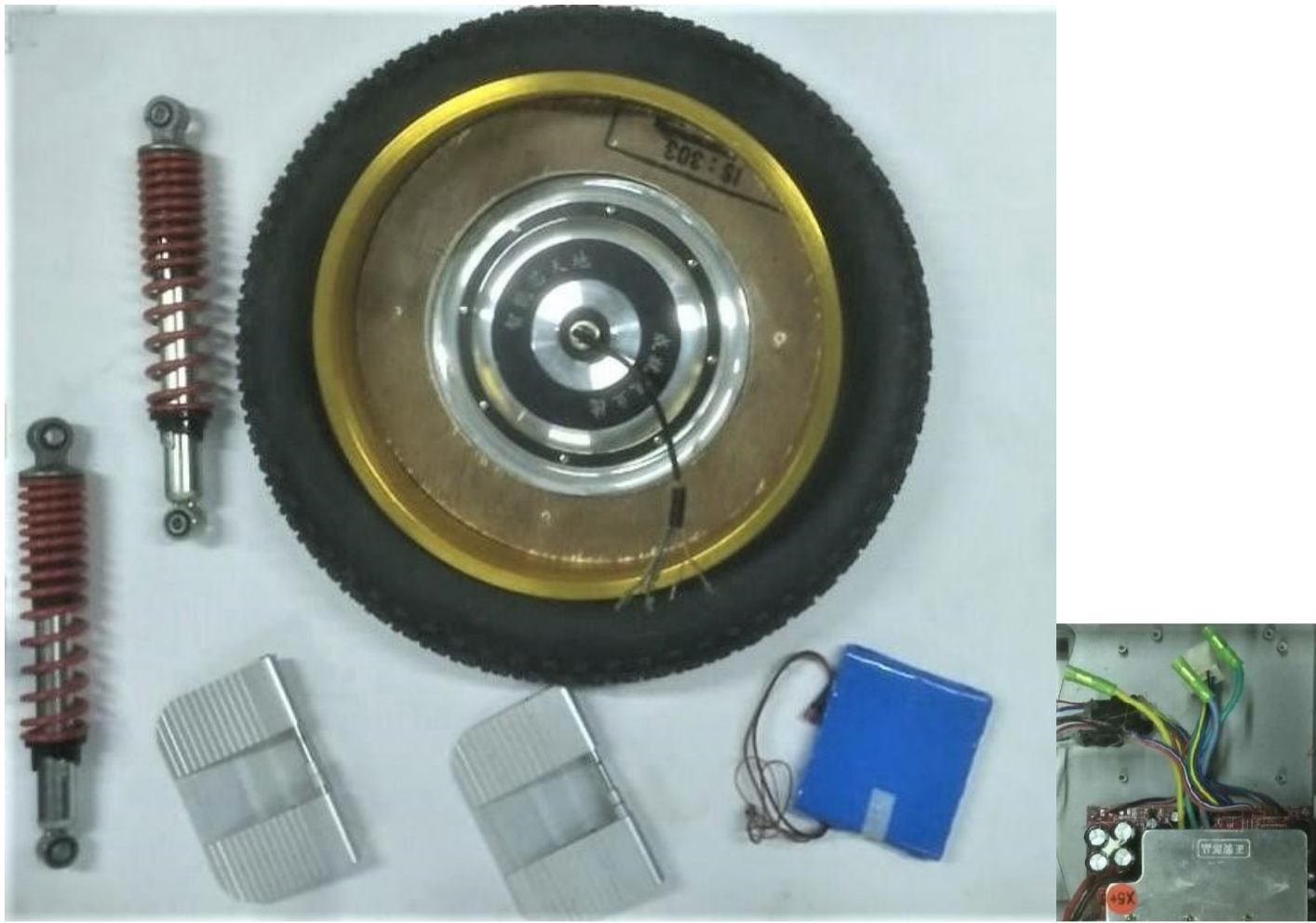

Figure 3.49 – Components used in Prototyping



Figure 3.50 – Pictures of working on the full scale working prototype



Figure 3.51 – Pictures of working on the full scale working prototype

3.8.3 Designing a sports ground

Here the design is inspired from the skateboard parks. there will be ramps and curbs. there will be uneven concrete blocks stuck into ground. there will be narrow and uneven passage between ramps and blocks like shown in Fig.- 3.48. riders will ride the vehicle between the blocks, climb on the blocks and ramps, they can jump from one block to nearby block. They can perform various stunts on the ground.



Figure 3.52 – Pictures of the scale model of the proposed sports ground

3.8.4 Business model

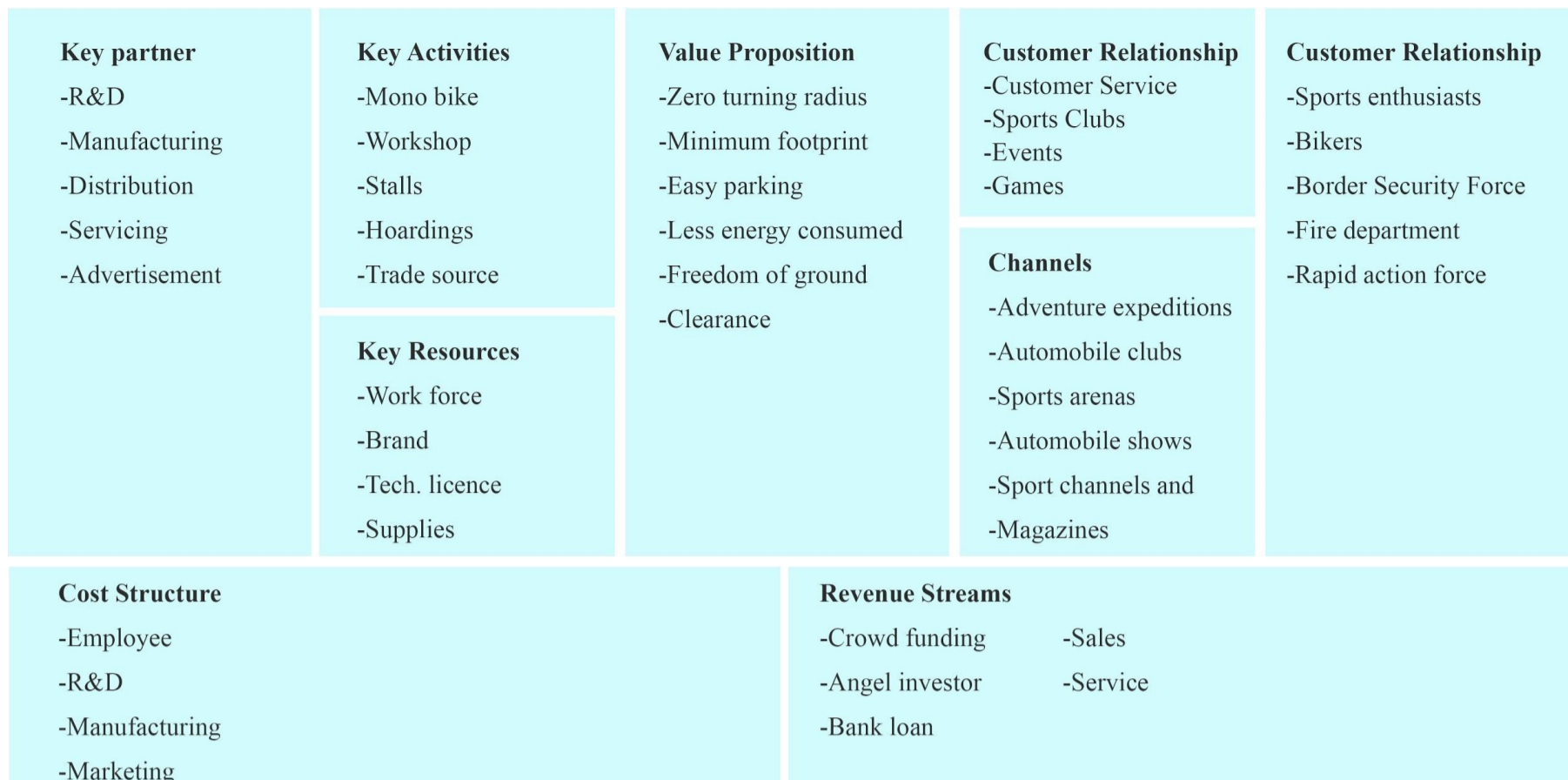

Figure 3.53 – Picture of the business model

3.8.5 Branding

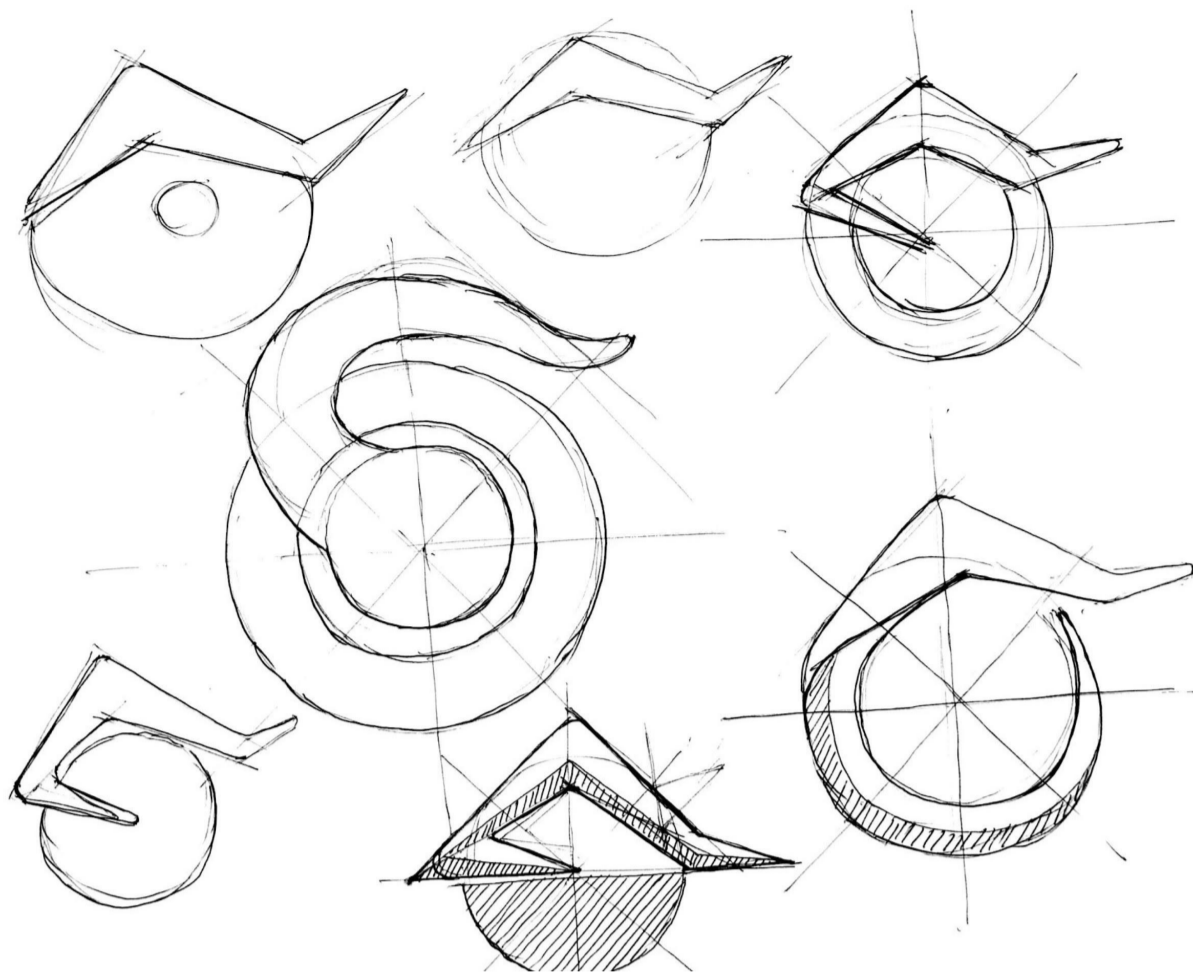

Figure 3.54 – Ideation sketch of the logo

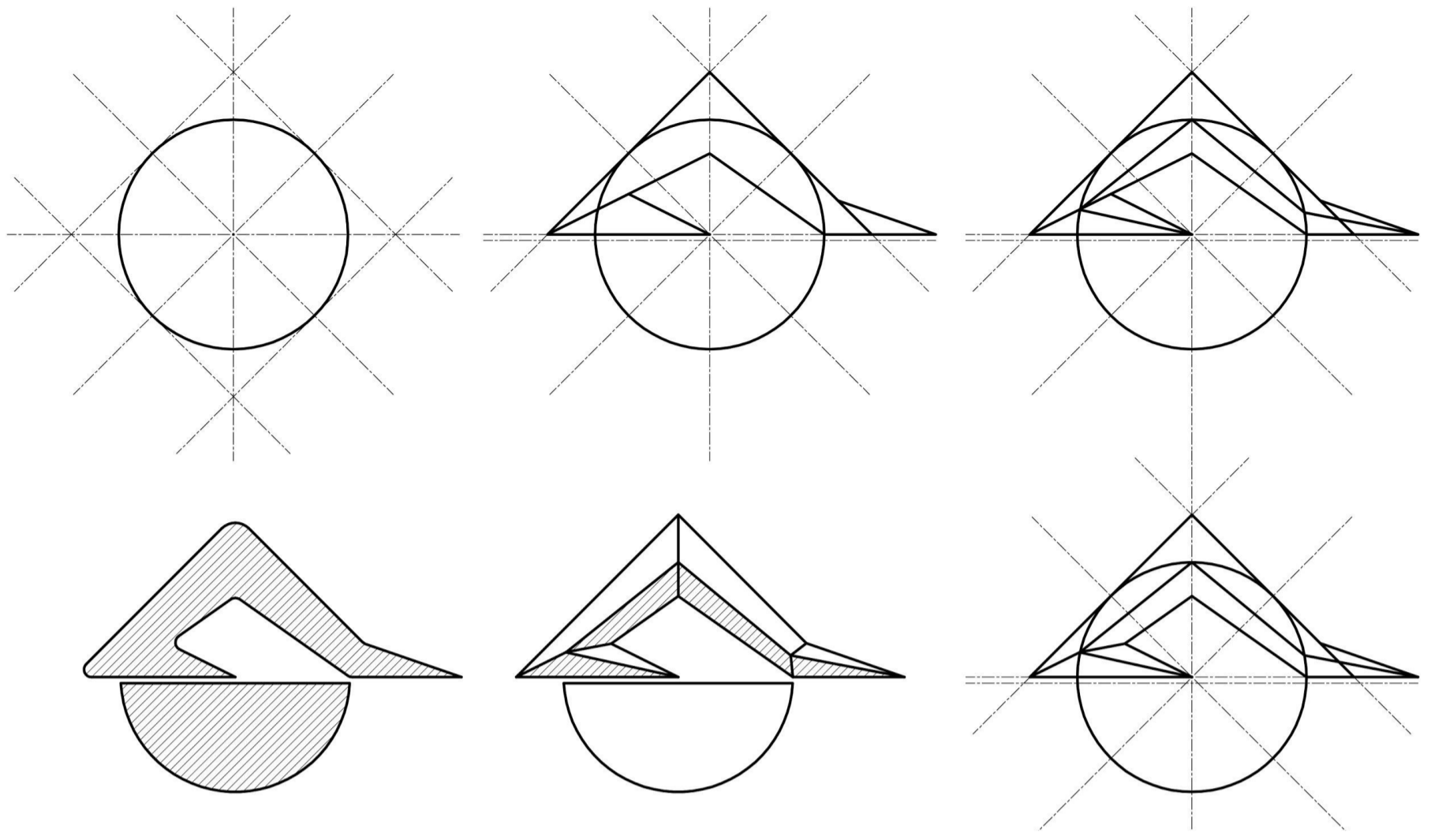

Figure 3.55 – Development of the logo

References

1. https://en.wikipedia.org/wiki/All-terrain_vehicle
2. <https://en.wikipedia.org/wiki/Tricycle>
3. <https://www.icetrikes.co/products/full-fat>
4. https://en.wikipedia.org/wiki/Types_of_motorcycles#Off-road
5. <https://www.ktm.com/en/freeride/freeride-250-f/>
6. <https://www.tvsmotor.com/blog/decoding-the-different-types-of-motorcycle-chassis/>