

AN ENTRY LEVEL ROYAL ENFIELD

Design project III (MVD.III - 28)

By

Ajithlal C M
146390005

Guide

Prof. Nishant Sharma,

Mr Jacob Thomas Davidson (iD Studio, Royal Enfield)



Industrial Design Centre
Indian Institute of Technology

2016

Acknowledgement

In acknowledgement, I would like to thank Prof. Nishant Sharma for guiding me in the project. I am very thankful for his support, patience and valuable inputs during this project.

I would also like to thank my family, my teachers and all my friends from IDC, for being a constant source of support and inspiration.

Ajithlal CM

Contents

Project brief	1
Timeline	2
1. Introduction	3
2. Abstract	4
3. Literature study	5
1. Brand study: Royal Enfield	6
2. Royal Enfield design language	11
3. Types of motorcycles	19
4. Entry level motorcycle from RE in the past	24
4. Market study	30
1. Why 250-300cc segment is important?	31
2. 250cc standard motorcycles	32
3. The competition	35
4. Market Positioning	40
5. Sales statistics and forecast	43
5. User Study	48
1. User groups	49
2. Questionnaire	50
3. User study outputs	52
6. Choosing the Engine/ Benchmarking	57
7. The Concept	59
8. Persona	60

9. Concept generation	62
1. Moodboard	63
2. Inspiration Board	64
3. The Classic	65
4. The Neo- Classic	67
5. The Modern	70
10. Concepts	75
1. The Classic	76
2. The Neo- Classic	78
3. The Modern	80
11 Concept finalizing	81
12 Final Concept	82
13 CAD Drawing	85
14 Ergonomic study	86
15 Physical model	87
16 Bibliography	90

1. Project Brief

To design an entry level motorcycle for Royal Enfield

Challenge:

Coming up with an entirely new motorcycle for RE which goes with company's DNA and its legacy.

Deliverables:

Final renders, 3d model, Physical scale model

2. Timeline

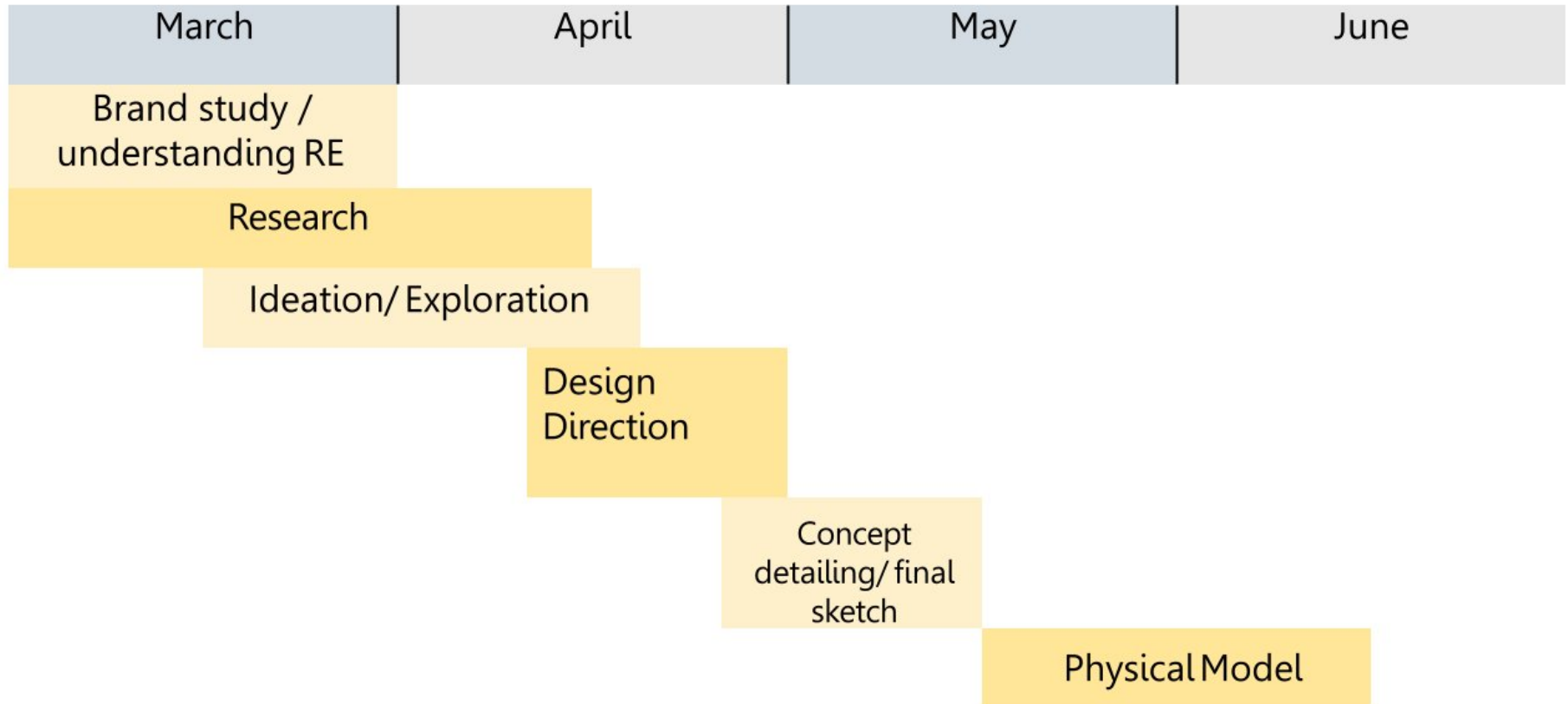

1. Introduction

Royal Enfield is motorcycle company which needs no Introduction. It is one of the oldest, if not the oldest motorcycle manufacturers in the world. After moving into India in 1955, RE has managed to make a huge loyalist following due to its old world charm and emphasize on pure motorcycling. This project is about designing an entry level motorcycle for Royal Enfield. The word 'entry level' does not mean that it is going to be a cheap commuter motorcycle. It represents accessibility more than affordability. This motorcycle is going to be the stepping stone to the Enfield world for those who are intimidated with the 'big bike' feel of Enfield's. The project will consist of studies of brand, market and the user. A scale model, and final renders would be the deliverables.

3. Literature Study

3.1 Brand Study: Royal Enfield



Oneness

Royal Enfield motorcycles bonds man, machine and terrain through unique riding experience



Timeless legacy

From 1901 to 2016, RE has been providing its riders with expert workmanship and handmadenature.

<http://royalenfield.com/ho/images/mobile/what-to-expect-2.jpg>

http://i1.wp.com/goodsparkgarage.com/wp-content/uploads/2014/04/ContinentalGT_museum.jpg



Hands - on

Users grow a special relationship with the bike through Maintaining, customizing and restoration



Inner Thump

motorcycles are created to deliver sensational joys to the riders. RE provides most authentic physical experiences a motorcycle can give.

<https://www.youtube.com/watch?v=O-JwZfLkX1U>



Fiercely Unique

Be it the styling, or the motorcycle characteristics, Royal Enfield has their own unique way of doing it. Instead of going after trends, the brand sticks to its defining values and makes motorcycles which provides pure motorcycling experience.

<https://pbs.twimg.com/media/CdmMKpdUYAAzymQ.jpg>

Royal Enfield now

Royal Enfield has become the epitome of classic motorcycling over the years. The brand's values have made them a huge fan following worldwide. In 2009, the average age of a Royal Enfield buyer was around 45 years, which has now come down to about 26 years. Royal Enfield does not boast of huge advertising budgets, rather they have systematically promoted their brand organically through in-store and customer experience and by organizing unique events around the brand. Like:

Rider mania

Rider Mania (RM) is an event hosted by Brotherhood of Bulleteers Motorcycling Consortium member clubs in India every year. It is the annual gathering of Indian Royal Enfield motorcycle owners. The event was initiated to commemorate the spirit of motorcycling. Riders and biking clubs across the country gather for the two day fest.

Himalayan Odyssey

Himalayan odyssey is a group ride of Royal Enfield motorcycles to the challenging paths to Himalaya mountains.

Way ahead for Royal Enfield

- Be the global leader in mid range motorcycles. (250 to 750cc)

Not only all of RE's current products belongs to this category, but they would like to keep on making motorcycles for this category as the world's midrange classic motorcycle segment is largely untapped. And this would keep them as a premium motorcycle brand.

- Be an iconic, aspirational yet approachable brand.

There are little or no brands which can keep up with the legendary heritage of Royal Enfield. That makes them an iconic brand. And being a lifestyle brand, they have certain aspirational value to them. Being approachable does not only mean being affordable, but being available/suitable for a wide range of audience.

3.2 Royal Enfield design language

1. Royal Enfield product lineup



1. Bullet

The bullet is the most iconic RE model. It holds the record for the longest running production model. It still retains the 50's motorcycle design cues. The name is synonymous for RE in India. It is powered by the iconic 350 / 500 cc single cylinder OHV Unit Construction Engine.



2. Classic

The Classic 500 motorcycle is a part of Royal Enfield's Retro Street series. The bike sports vintage and retro styling that distinguishes itself from the rest of the motorcycles on the road today. The Classic range is one of the highest selling motorcycles in Royal Enfield's range

Images are
Copyright © 2012 Team-BHP.com

<http://www.totalmotorcycle.com/motorcycles/2012models/2012-RoyalEnfield-Bullet500B5-EF11.jpg>

<http://www.team-bhp.com/forum/attachments/motorbikes/488587d1295951626-royal-enfield-500-classic-thread-c5-colour-option-01.jpg>



3. Thunderbird

Thunderbird is RE's cruiser model. It marked company's departure from being the makers of only the Bullet.



4. Continental GT

The Royal Enfield Continental GT is the lightest, fastest, most powerful Royal Enfield in production. It's a machine with a story, a nod to motorcycling's finest hour; a painstaking collaboration. It is also the best expression yet of a cultural phenomenon that has simply refused to fade away - the café racer.

<https://plus.google.com/103577172763263139485/posts>

http://royalenfield.com/images/data/motorcycles/slider1/continentalGT_right-side_red_600x463_motorcycle.png



5. Himalayan

Himalayan is India's first purpose built adventure motorcycle. It is a big step forward for RE in terms of design and engineering. It is powered by an all new 410 cc SOHC 4stroke engine.

3.2.2 Royal Enfield design Features



Vertical cylinders

1. Cast Iron
2. AVL Lean burn
3. Unit Construction Engine
4. LS410

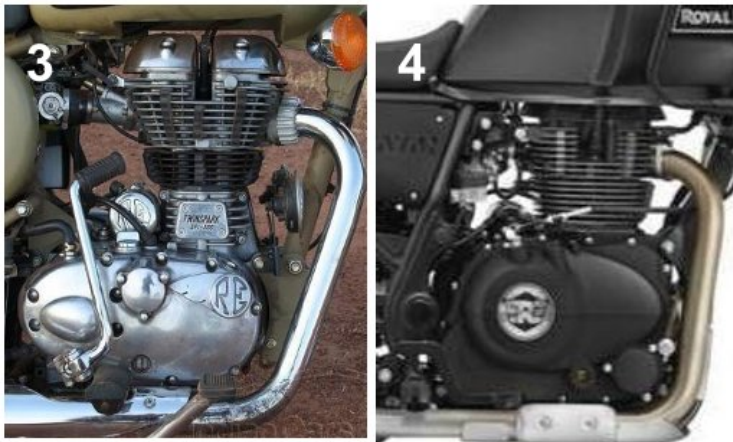

<http://www.realclassic.co.uk/enfield04101403.jpg>

<http://www.indiancarsbikes.in/wp-content/uploads/2012/01/Royal-Enfield-Desert-Storm-500cc-Single-Cylinder-UCE-Engine.jpg?3a87fd>

http://ic1.maxabout.us/autos/tw_india//N/2016/2/new-royal-enfield-himalayan-410-p.jpg



Casquette

Casquette, also known as nacelle is the result of combining the headlamp, instrument panel, key fob and the top yoke together. Most of the classic motorcycle had this feature, but Royal Enfield has a uniquely shaped one and they are still making it.



Round headlamp

<http://bikeadvice.in/wp-content/uploads/2010/11/Bullet-Electra-TwinSpark-350cc-Review-11.jpg>



Exposed frame, spoke wheels

Royal Enfield still produces motorcycles which has been in production for more than 50 years, with modern technology and components. But the way they visually treat the structural components remains same.

3.2.3 : Silhouettes



Bullet



Continental GT

3.2.4 .Proportions

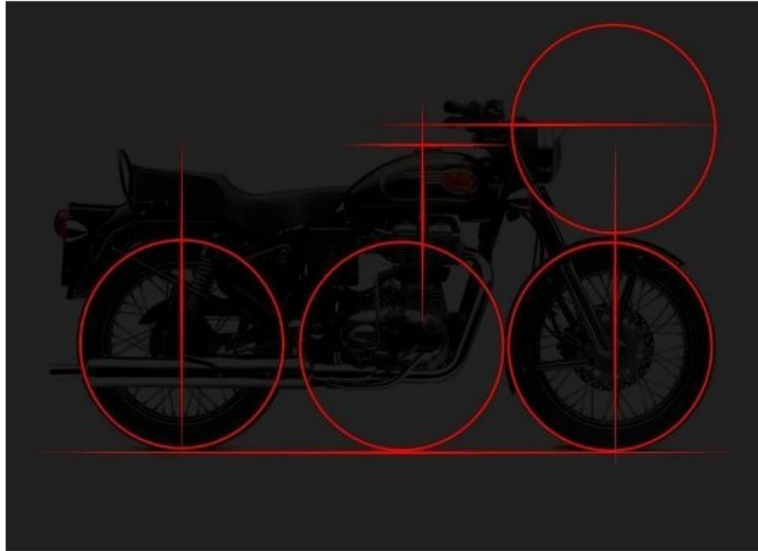

Bullet

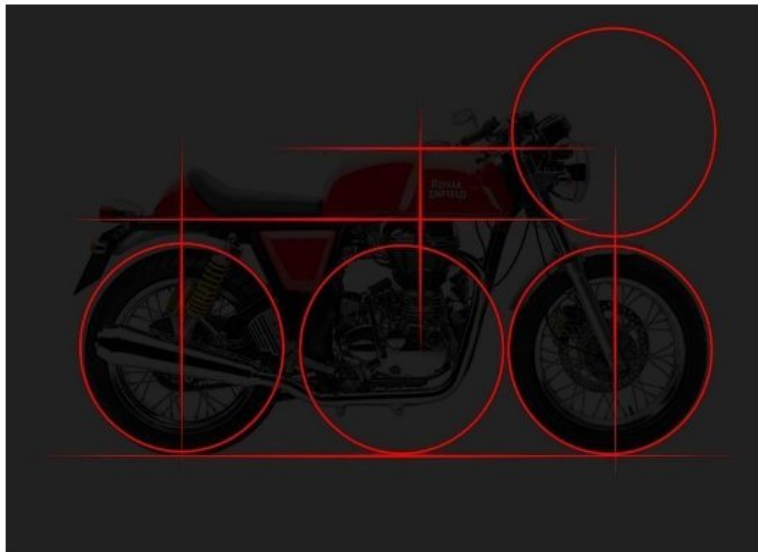

Continental GT

3.3 : Types of Motorcycles



1. Touring

A touring motorcycle is a type of motorcycle designed for long-distance touring and heavy commuting. Although any motorcycle can be used to tour with, manufacturers have brought specific models designed to address the particular needs of these riders.



2. Cruiser

The riding position on a cruiser places the feet forward and the hands up, with the spine erect or leaning back slightly. Chopper-style motorcycles are considered cruisers. Many cruising motorcycles have limited performance and turning ability due to a low-slung design.

<http://www.motorcycltouringpro.com/types-of-motorcycles/>



3. Sport

A sport bike is a motorcycle optimized for speed, acceleration, braking, and cornering on paved roads, typically at the expense of comfort and fuel economy in comparison to less specialized motorcycles. With the emphasis of a sport bike being on speed, acceleration, braking, and maneuverability



4. Standard

Standards are versatile, general purpose street motorcycles. They are recognized primarily by their upright riding position, partway between the reclining posture of the cruisers and the forward leaning sport bikes.



5. Scooters

Scooter engine sizes range smaller than motorcycles, and have all-enclosing bodywork that makes them cleaner and quieter than motorcycles, as well as having more built-in storage space. Scooters usually have smaller wheels than motorcycles.



6. Dual purpose

Dual-sports, also known as dual-purpose, are street legal machines that are also designed to enter off-road situations. Typically based on a dirt bike chassis, they have added lights, mirrors, signals, and instruments that allow them to be licensed for public roads. They are higher than other street bikes, with a high center of gravity and tall seat height, allowing good suspension travel for rough ground.



6. Enduro

An Enduro motorcycle is a motorcycle specially made for the Enduro sport, with the long travel and medium- hard suspension of a motocross bike conjoined with features such as a headlight and quiet muffler to make the bike street-legal for parts of the track. Enduro motorcycles most closely resemble Motocross motorcycles



7. Motocross

A Motocross motorcycle is a bike built specifically for the sport of Motocross



8. Trials

Trial motorcycles are distinctive in that they are extremely lightweight, lack seating (they are designed to be ridden standing up) and have suspension travel that is short, relative to a motocross or Enduro motorcycle. Motorcycle trials, also termed observed trials, is a non-speed event on specialized motorcycles

3.4 Entry level bikes from RE in the past

A study about the entry level motorcycles from Royal Enfield was required because history is an important factor which determines whether a motorcycle is RE or not. The study will help in finding an appropriate motorcycle to take inspiration from its philosophy.

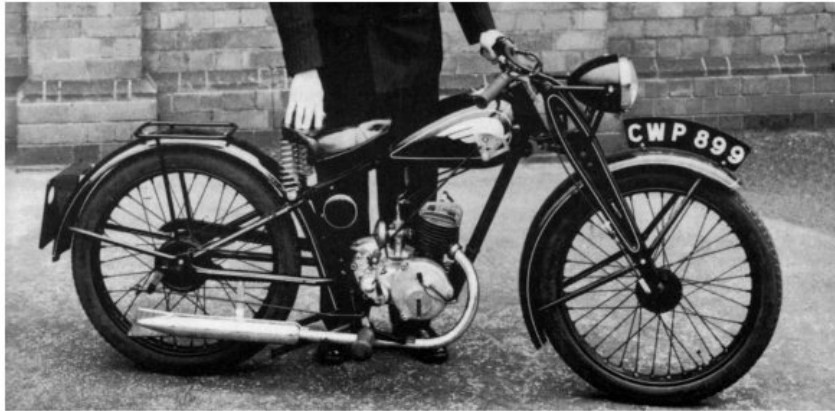

1. Model A (1930)

225cc 2 stroke single cylinder. Introduced as a lightweight, affordable commuter motorcycle.



2. Model B (1930)

225cc 4 stroke single.

https://greasengasoline.files.wordpress.com/2011/09/royal-enfield-model-re-252-7flyingflea2527_01.jpg

https://c1.staticflickr.com/3/2567/4008640309_4e93c26a00_z.jpg%3Fz%3D1



3. Flying Flea

125cc 2 stroke single on a DKW RT motorcycle. Was made for war purposes. Ultra lightweight parachute-able motorcycle.



4. Ensign (1952)

148cc 2 stroke single. Cheap to buy and cheap to run motorcycle. Ensign II and III were followed.

<http://www.welbike.net/re%2002.jpg>

<https://greasengasoline.files.wordpress.com/2012/08/royalenfieldensign150cc0013.jpg>



5. Prince (1959)

148cc 2 stroke single. Modified Ensign.



6. Mofa

In the late-1980s, Enfield India produced the 22cc, two-stroke, single cylinder Mofa for a cost-conscious market. The engine produced just 0.8 bhp



7. Crusader

Royal Enfield Crusader of 1957 was a sporty 250cc roadster, which sold in huge numbers, and was the basis for the iconic Continental GT cafe racer. It was produced from 1957 to 1965. Crusader came with tagline of 'for modern motorcycling'. It had the First Unit Construction Engine in any Royal Enfield. It had a 248cc Oversquare engine (70*64.5), where other RE's had undersquare engines conventionally. It was a compact motorcycle. (air box- battery and tools into a singlebox). In 1959, Crusader sports was launched. Crusader sports with high compression pistons (8.5:1 vs 8:1) racing cams, larger valves made 17 bhp, compared to 16 of older 350cc engine of same time. 1962- Super 5. was introduced. It had a 5 speed gearbox. Possibly the first motorcycle with 5 speed gearbox. Continental GT, fastest 250cc motorcycle of its time was built on the crusader.

The Crusade seems to be the most appropriate motorcycle to take inspiration from as it was an entry level, but premium motorcycle. While other models were about cheap commuting, Crusader was a compact, sporty, and technically advanced motorcycle. The concept is still relevant now. A more detailed study of Crusader is required.

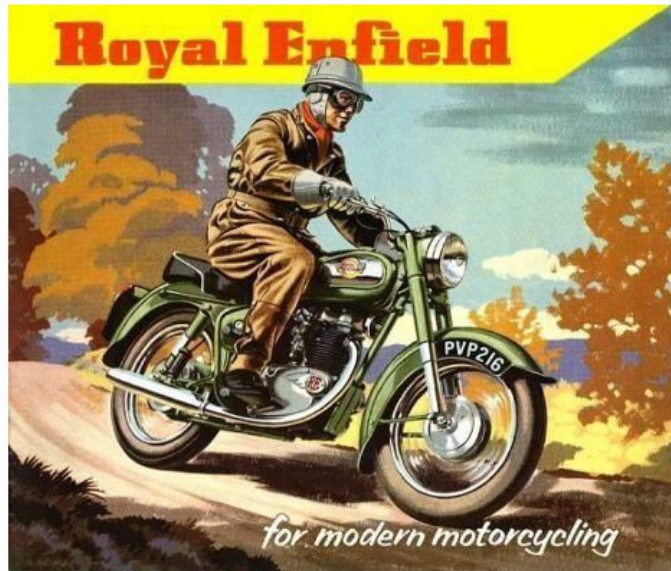

A 1957 advertisement of RE Crusader. "formodern motorcycling" was the tagline.



It was aimed at the young generation. It was a more compact motorcycle, allowing it to be a unisex model.

http://www.planetbt.com/royalenfield/pics/1957_Ad_2.jpg
http://www.royal-enfield.net/posters/Crusader_Ad.jpg

The sensational NEW
CRUSADER SUPER 5

5 SPEED GEARBOX

LEADING LINK FORKS

BRILLIANT NEW COLOUR FINISH

SLEEK SPORTING STYLE

EVEN HIGHER OUTPUT

See your Dealer for details of the economical **ROYAL ENFIELD** New Purchase Plan.

Royal Enfield

NAME _____
 ADDRESS _____
 POST CODE _____

THE ENFIELD CYCLE CO., LTD., REDDITCH, WORCESTERSHIRE

A later version of Crusader (Super 5) had a 5 speed gearbox. It is possibly the first motorcycle to have one. This version shows the sporting intention of Crusader.

4. Market study

4.1 Why 250-300cc segment is important?

As Royal Enfield needs an entry level motorcycle, a 250-300 cc is a perfect engine considering the following factors:

- Considered as entry level sports bike segment
- Best of both worlds (performance + practicality)
- Sets apart from commuter segment, providing exclusivity.
- RE wants to be the segment leader (250cc – 750cc)*
- RE wants to be a more accessible brand.

*<https://www.bikedekho.com/bike-news/royal-enfield-wishes-to-become-global-leader-in-250-650cc-motorcycles.html>
<http://royalenfield.com/re-world/news/royal-enfield-re-ignites-mid-size-motorcycling-with-the-new-continental-gt-cafe-racer/>

4.2 250cc standard motorcycles (international)



Suzuki TU 250x

The TU250 — marketed also as the TU250X, ST250 and ST250 E-Type — is a single-cylinder, air-cooled, single overhead cam (SOHC), four-stroke, chain-drive motorcycle launched by Suzuki in 1994 as a lightweight, street bike with a standard riding posture and styling resembling the Universal Japanese Motorcycle (UJM) of the 1960s and 1970s..



Honda Rebel 250

The Honda CMX250, or Rebel 250, is a 234 cc cruiser-style motorcycle made by Honda on and off since 1985. It uses the same 234 cubic centimeters straight-twin engine as the Honda Nighthawk 250 standard. The Rebel is part of the CM series of cruisers. It is commonly used in the Motorcycle Safety Foundation's certified rider-training courses.



Kawasaki BJ 250

Air-cooled, Single Cylinder, 4-stroke Displacement
249cm³



Cleveland misfit 250

American designed, Chinese made motorcycle. 249 cc
SOHC 4 stroke engine. Designed to provide the rider
with a simple and back to the basics motorcycling
experience.

<http://www.motorcyclespecs.co.za/Gallery/Kawasaki%20BJ%20250%20Estrella%2092.jpg>

<http://bikeglam.com/wp-content/uploads/2012/03/2012-Cleveland-Cyclewerks-Misfit-250-630x420.jpg>



Herald Classic 250

British designed, Chinese made motorcycle. 250cc SOHC 4stroke engine. Designed to look like 1970's triumph Bonneville.



Yamaha V Star 250

Yamaha's entry level 250cc cruise styled motorcycle. It has a 249cc air cooled 60 degree v twin engine.

<http://www.haywards.co.uk/herald-classic-250cc.html>

<http://motorcycles.axlegeeks.com/l/1548/2014-Star-V-Star-250>

4.3 The competition (Indian market)

- Benelli tnt 250 (₹ 1,68,000)
- Husqvarna Vitplien(2017)
- Kawasaki Z250 (₹ 3,11,128)
- Yamaha MT 25 (₹ 2,50,000)
- KTM Duke 200/390 (₹ 1,60,000)
- Mahindra Mojo (₹ 1,75,000)
- BMW/TVS G310 R (₹ 2,25,000)
- Honda CBR 300/ 250 (₹ 1,60,201)
- HyosungGT250R

4.3.1 Specs comparison

1. Dimensions

	KTM 390	Duke	Benelli 250	TNT	Kawasaki Z250	Yamaha MT25	Mahindra Mojo	Honda 250	CBR	BMW G310R
Length	2002mm		2080mm		2010mm	2090mm	2100mm	2032mm		1988mm
Width	873mm		810mm		750mm	745mm	800mm	720mm		896mm
Height	1274mm		1125mm		1020mm	1035mm	1165.5mm	1127mm		1227mm
Seat Height	800mm		780mm		785mm	780mm	814.5mm	780mm		785mm
Ground Clearance	170mm		160mm		145mm	160mm	173.5mm	145mm		
Wheel Base	1367±15mm		1400mm		1400mm	1380mm	1465mm	1367mm		1374mm
Kerb weight	154kg		159kg		168kg	165kg	182kg	163kg		158.5kg

2. Engine and gearbox specs

	KTMDuke 200	BenelliTNT 250	Kawasaki Z250	Yamaha MT25	Mahindra Mojo	HondaCBR 250	BMWG310R
Displacement	199cc	249cc	249cc	249cc	294.72 cc	249.6cc	313cc
Max.Power	25 Bhp@ 9500rpm	28.16 BHP @ 9800rpm	31.5 Bhp@ 11000rpm	35.5 BHP @ 12000rpm	26.82 BHP @ 8000rpm	26.15 Bhp@ 8500rpm	33.6 BHP @ 9500rpm
Max.Torque	19.2 Nm@ 7250rpm	21.61 NM@ 8000rpm	21 Nm@ 10000rpm	22.6 NM@ 10000rpm	30 Nm@ 5500rpm	22.9 Nm@ 7000rpm	28 NM@ 7500rpm
Description	1-cylinder 4-stroke engine, water-cooled	249cc, Single cylinder, 4-stroke, 4-valve, Liquid-cooled, DOHC	249cc, DOHC, 2-cylinder, 4-stroke	Liquid-cooled, four-stroke, DOHC, 4-valve	Liquid-cooled, Single Cylinder, 4-stroke, Si Engine, DOHC	Liquid cooled, 4-stroke, DOHC, 4-valve	single-cylinder 4-stroke engine
Gearbox	6 speed, claw shifted	6-speed Transmission	6-Speed, Constant Mesh Type, Return Shift	6 Speed Manual Transmission	Constant Mesh 6-speed	6-Speed, Constant mesh	Synchromesh 6-speed transmission

3. Suspension and Wheel travel

	KTMDuke 390	BenelliTNT 250	Kawasaki Z250	Yamaha MT25	Mahindra Mojo	HondaCBR 250	BMWG310R
Front suspension	43mm upside downforks	Inverted Telescopic Forks	37mm Hydraulic Telescopic Fork	Telescopic Fork 41mm	USD(upside down) telescopic forks	Telescopic Fork	Upsidedown fork , Ø41 mm
Rear suspension	Monoshock	Mono Shock Absorber	Bottom-link Uni-Trak	Suspension Monocross	mono-shock	monoshock	directly hinged monoshock
Frontwheel travel	150 mm		119 mm		143.5 mm		140mm
Rearwheel travel	150 mm		119 mm		143 mm		131mm

4. Brakes and tires

	KTMDuke 390	BenelliTNT 250	Kawasaki Z250	Yamaha MT25	Mahindra Mojo	HondaCBR 250	BMW G310R
FrontBrake	300mm disc, 4 pot caliper	385mm Petal Disc	290mm Singledisc,	Floating Single DiscØ 298mm	320mm Petal Disc Brake	296mm Disc Dia	300 mm, 4- piston
RearBrake	230mm disc, 2 pot caliper	318mm Petal Disc	220mm Singledisc	Single DiscØ 220mm	240mm Petal Disc Brake	220mm Disc Dia	240mm, single-piston
Front tyre	110/70R17	110/70R17, 54H	110/70-17	110/70- 17M/C	110/70ZR17	110/70	110/70R17
Rear tyre	150/60R17	150/60R17, 66H	140/70-17	140/70- 17M/C	150/50ZR17	140/70	150/60R17

4.4 Market positioning

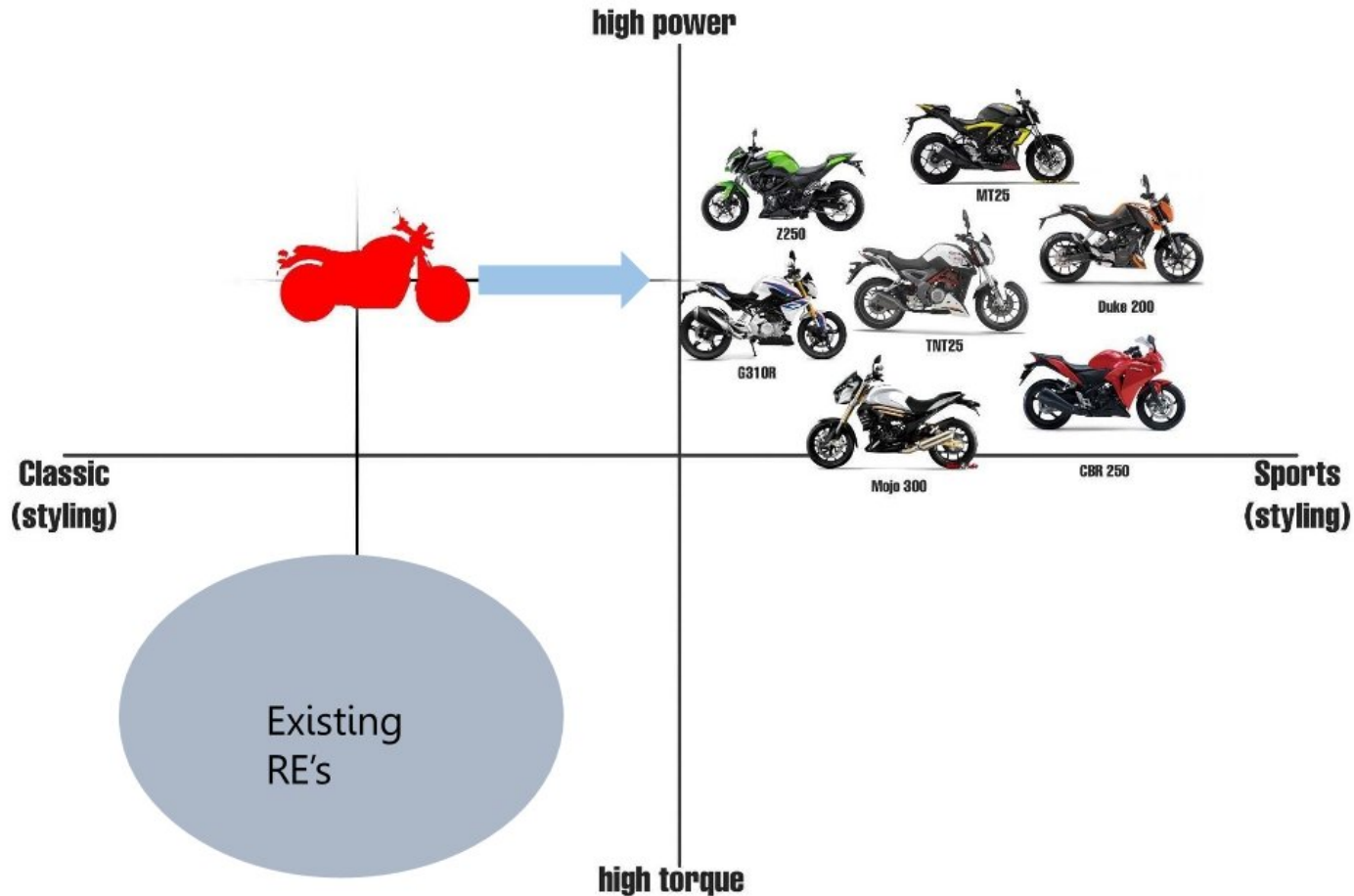

The proposed motorcycle is so positioned that it has a high power engine so that it can compete with the 250cc- 300cc competition but has a styling which makes it stand out from the crowd. The engine should retain typical RE properties.

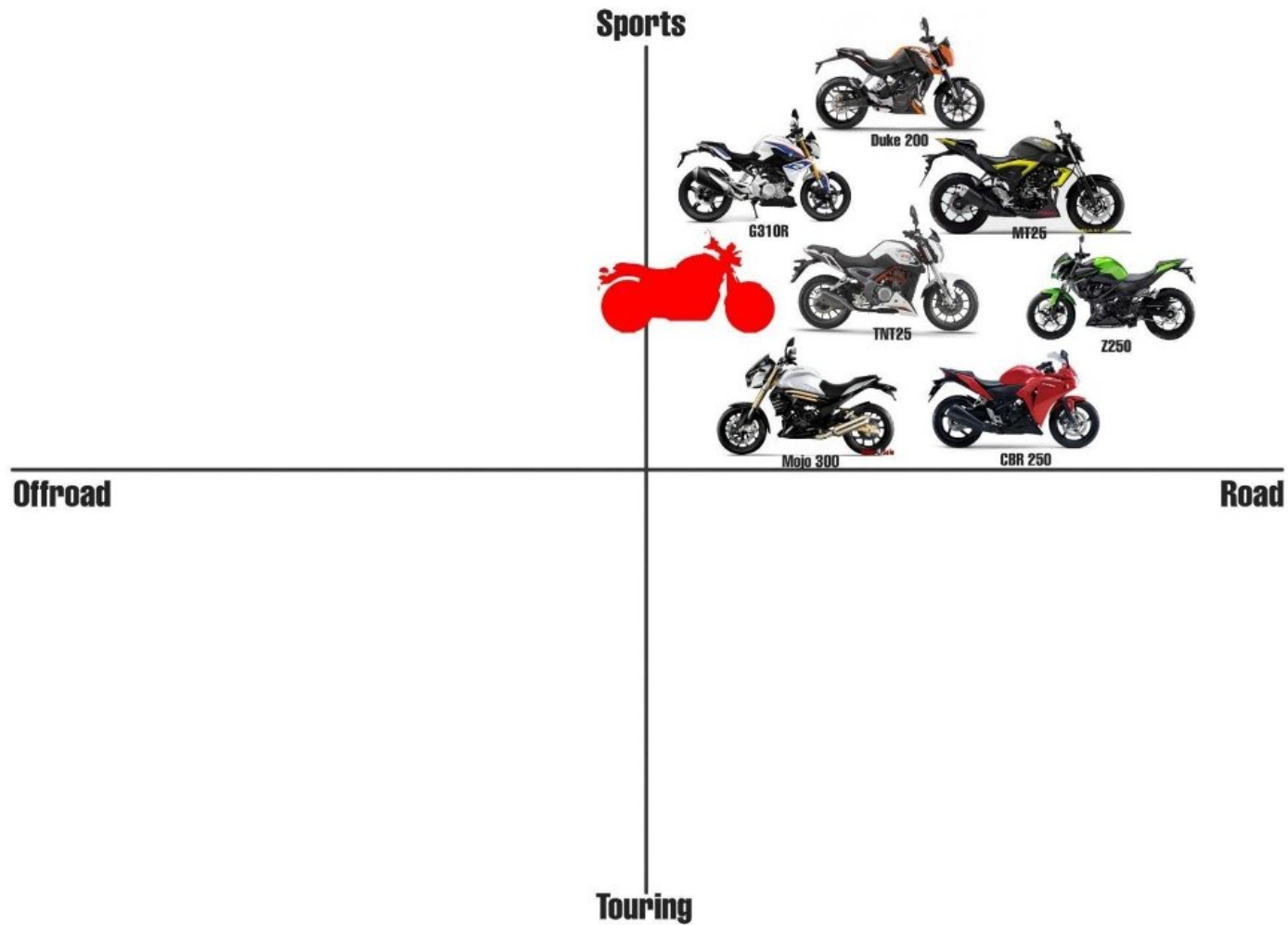

The proposed motorcycle is so positioned that it has a high power engine so that it can compete with the 250cc- 300cc competition but has a styling which makes it stand out from the crowd. The engine should retain typical RE properties.

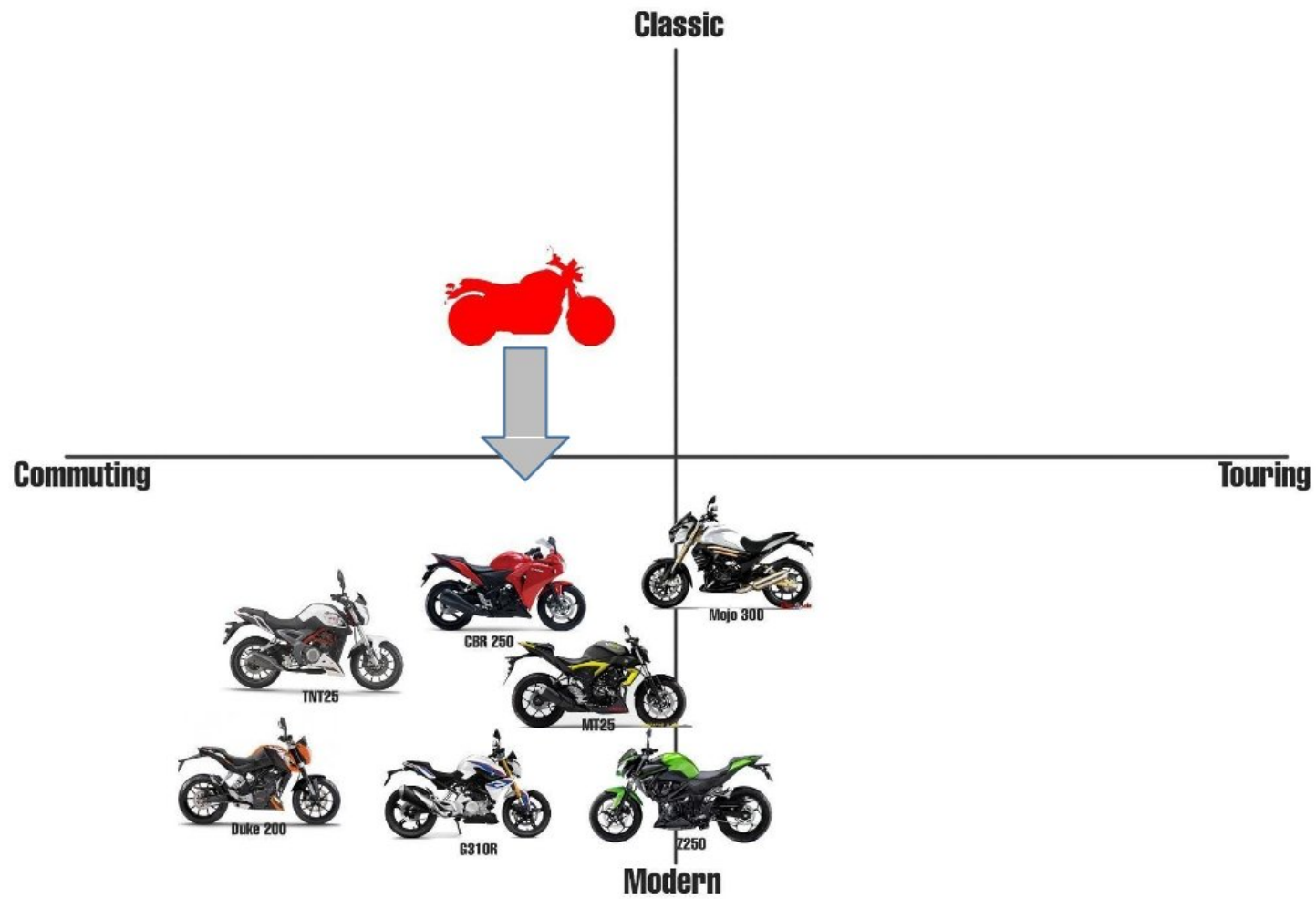

4.5 Sales statistics and forecast

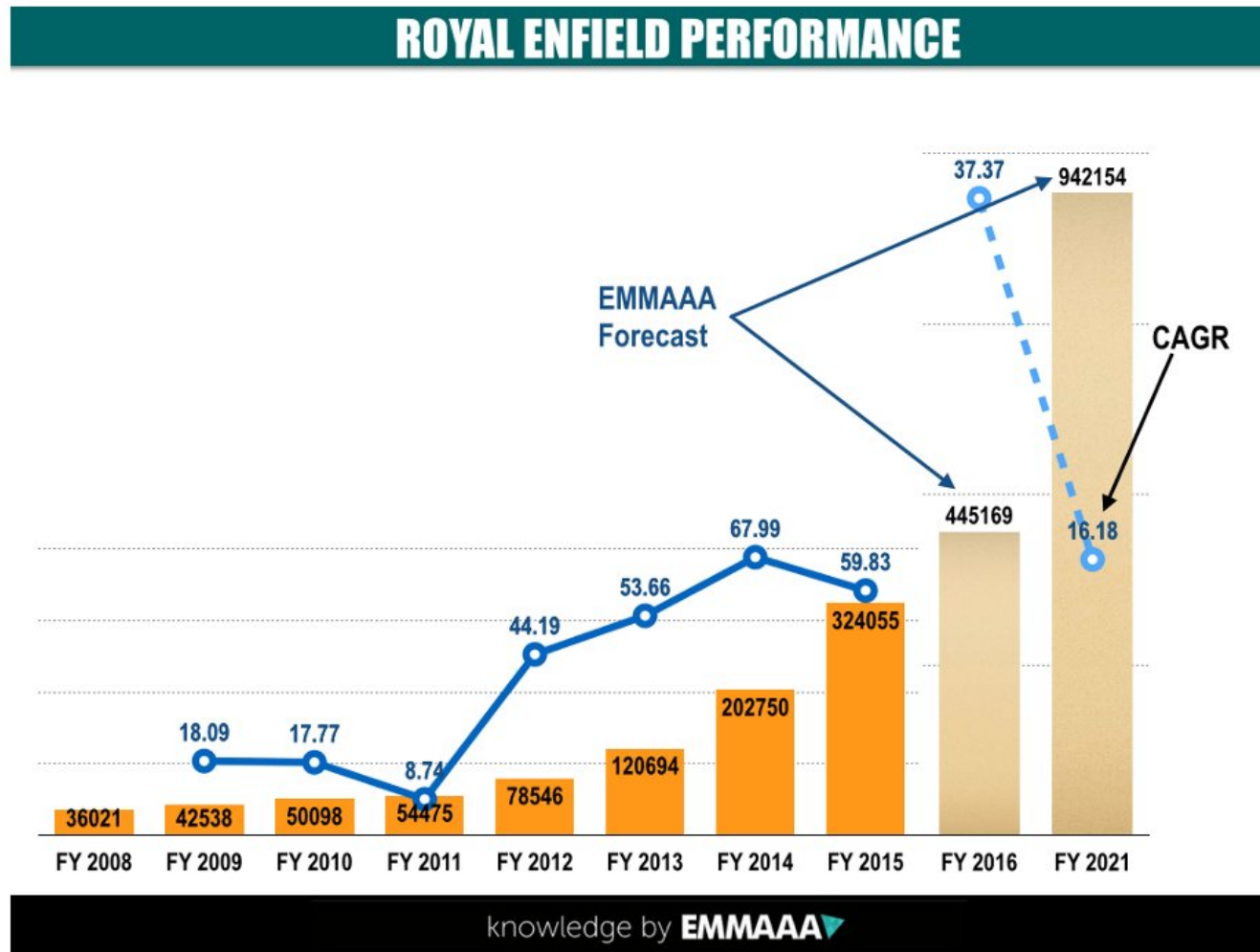

Royal Enfield's sales increasing in a rapid manner every year. It is clear that RE's product placement and systematical brand promotion have seen good results.

SALES BY ENGINE SIZE

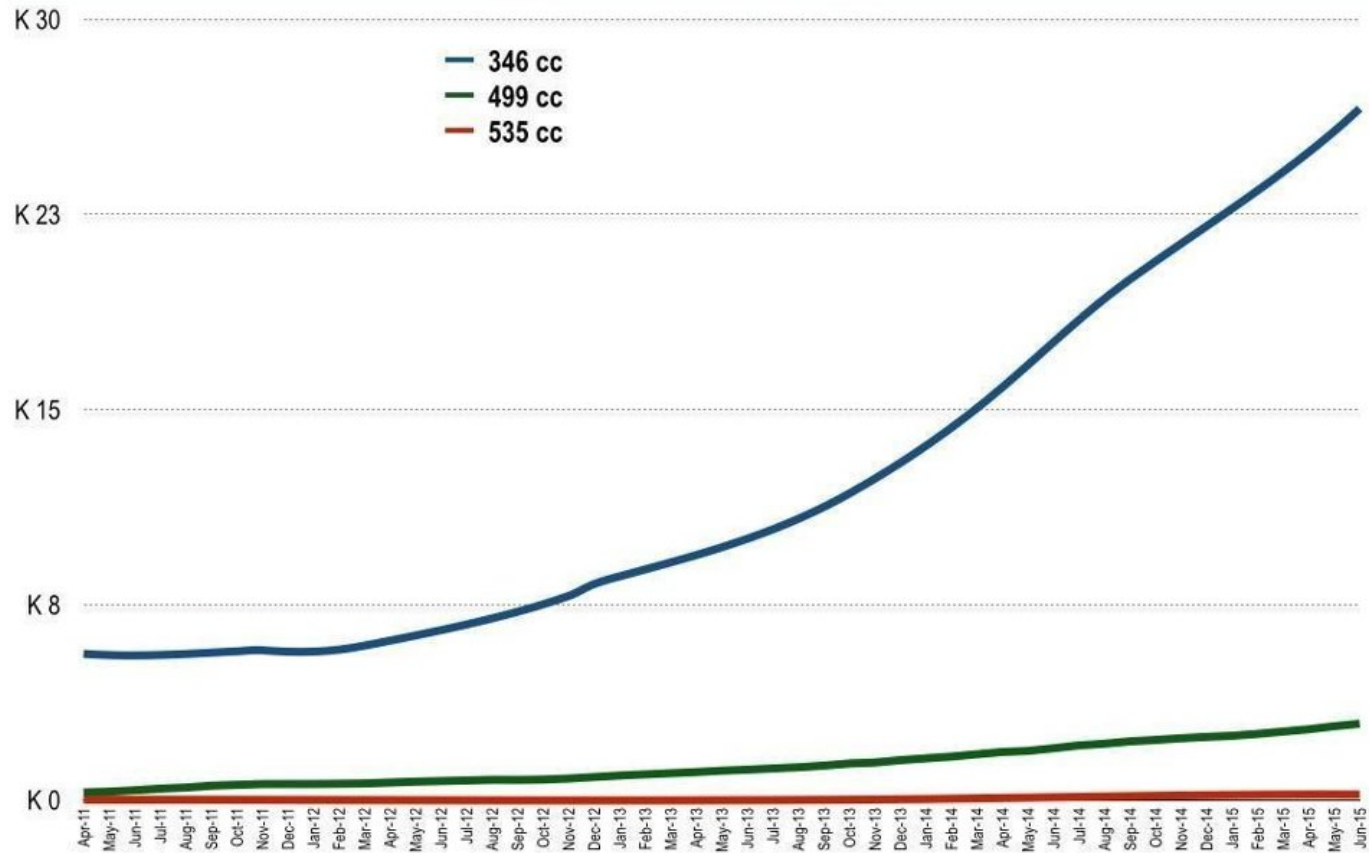

According to the sales figures, the lower capacity motorcycle sales are much higher than highercapacity ones and their sales are increasing exponentially. Introducing a lower capacity motorcycle makes so much sense here.

REML-EXPORTS

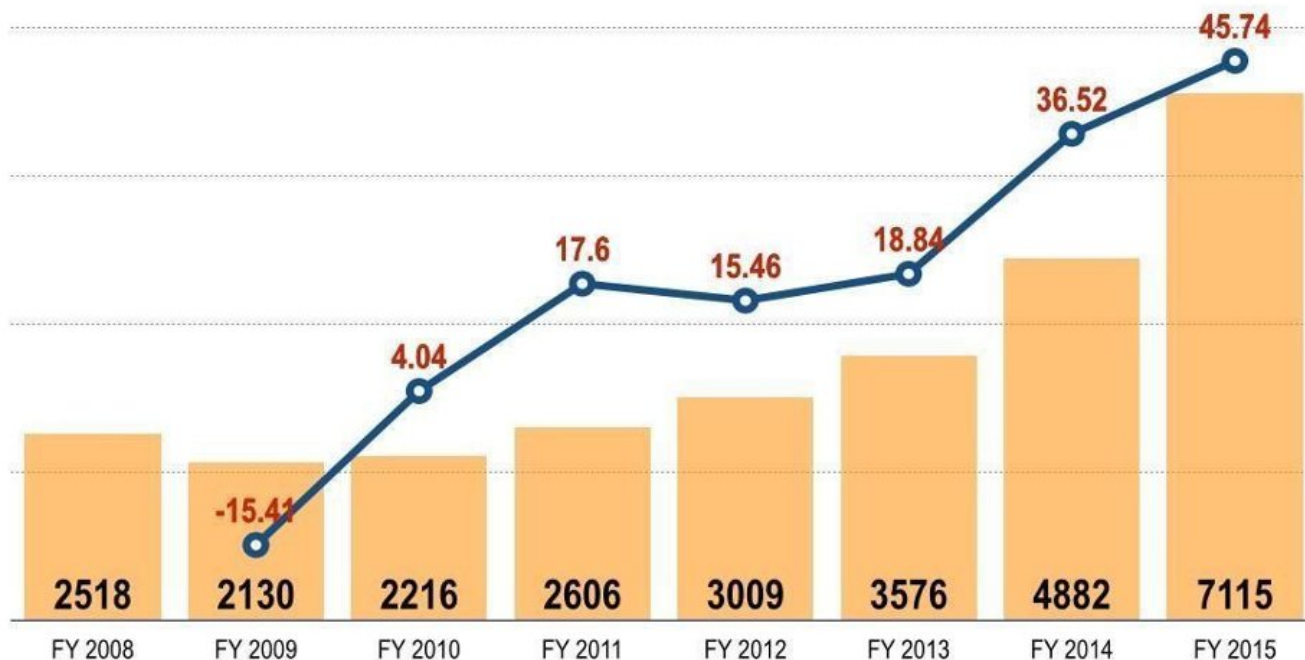

The exponentially increasing export numbers show that they are well acclaimed internationally. The new motorcycle should have international appeal also.

Top 10 Motorcycles sold in July 2015		
	Models	Units Sold
1	Hero Splendor	1,77,016
2	Hero Passion	94,291
3	Hero HF Deluxe	77,264
4	Honda CB Shine	63,695
5	Hero Glamour	61,221
6	Bajaj Pulsar	50,270
7	Bajaj CT	42,829
8	Honda Dream	27,479
9	Bajaj Discover	23,230
10	Royal Enfield Classic 350	21,719

<http://www.autocarpro.in/IMG/520/12520/top-10-bikes.jpg>

Top 10 Motorcycles in January 2016		
Sr No	Models	Units Sold
1	Hero Splendor	1,99,345
2	Hero HF Deluxe	1,07,272
3	Hero Passion	80,261
4	Honda CB Shine	76,562
5	Hero Glamour	63,009
6	Bajaj Pulsar	46,314
7	Bajaj CT	32,890
8	Bajaj Avenger	28,085
9	Royal Enfield Classic 350	27,362
10	Honda Livo	22,762

<http://www.autocarpro.in/IMG/331/17331/bikes.jpg>



Royal Enfield's overall sales have surpassed that of Harley Davidson during the year 2013. It boosts company's ambition of becoming the global leaders of mid range capacity motorcycles.

In 2009, the average age of a Royal Enfield buyer was around 45 years, which has now come down to about 26 years.*

REML has a huge global opportunity — **the affordable classic mid-size bike market** is under-penetrated across the world. Even though **Harley-Davidson** has come down the engine class with the Street 500, it being a twin and much more expensive than the **Royal Enfield** offerings means that both are essentially fighting in **different areas of the market**. Others like Triumph end up even higher and are twins as well. There are plenty of obscure Russian, Chinese, Czech and Global manufacturers but **none of them has a heritage matching Royal Enfield**.

<http://www.theautomotiveindia.com/forums/attachments/two-wheelers/160893d1422866976-monthly-sales-figures-indian-bikes-graph.jpg>

*<http://www.enfieldmotorcycles.in/2009/08/enfield-faces-no-threat-from-tatas-rs-1.html>

* <http://qz.com/348552/how-royal-enfield-won-over-the-indian-motorcyclist-and-now-looks-unstoppable/>

*http://www.exchange4media.com/marketing/royal-enfield-profits-up-by-33-compared-to-harley-davidson-in-2015_63595.html

5. User study

5.1 User groups

The Youth (20 – 30 yrs)
First premium motorcycle.
Commuting, leisure trips
Looking for performance

The Enthusiast (25-40 yrs)
Owns a higher capacity motorcycle.
Leisure trips
Brand value, Image.

A questionnaire was prepared for understanding the user preferences and expectations of a 250cc motorcycle..

5.2 Questionnaire

3/29/2016 250cc Motorcycle preferences

250cc Motorcycle preferences

To study the common preferences of potential 250cc motorcycle customers.

1. Name

.....

2. Age

.....

3. Profession

.....

.....

.....

.....

4. Which is your current motorcycle?

.....

.....

.....

.....

.....

5. Which is your favorite motorcycle/s ? and why?

.....

.....

.....

.....

.....

<https://docs.google.com/forms/d/138UD3FBOIkpdWma7uHWGP6g8tqjic1MwFvFYzPGkled#responses> 1/4

3/29/2016 250cc Motorcycle preferences

6. Which is your most used motorcycle? and why?
(answer if you have used more than one motorcycle)

.....

.....

.....

.....

.....

7. What do you use your motorcycle for?
eg: commuting, weekend rides, long trips etc

.....

.....

.....

.....

8. What do you wish to do with your motorcycle?

.....

.....

.....

.....

9. What according to you is the suitable price range of a 250cc motorcycle?
Mark only one oval.

Rs 80,000 to 1,00,000

Rs 1,00,000 to 1,20,000

Rs 1,20,000 to 1,40,000

Other:

10. Would you like to customize your motorcycle?
Mark only one oval.

Yes

No

<https://docs.google.com/forms/d/138UD3FBOIkpdWma7uHWGP6g8tqjic1MwFvFYzPGkled#responses> 2/4

11. How do you like your motorcycle ?Looks
Mark only one oval.

1	2	3	4	5	
Old school	<input type="radio"/>	<input type="radio"/>	<input type="radio"/>	<input type="radio"/>	Modern

12. Mark only one oval.

1	2	3	4	5	
Minimal	<input type="radio"/>	<input type="radio"/>	<input type="radio"/>	<input type="radio"/>	Fully faired

13. Mark only one oval.

1	2	3	4	5	
Aggressive	<input type="radio"/>	<input type="radio"/>	<input type="radio"/>	<input type="radio"/>	Friendly

14. Performance

Mark only one oval.

1	2	3	4	5	
Low end pull	<input type="radio"/>	<input type="radio"/>	<input type="radio"/>	<input type="radio"/>	Top end pull

15. Mark only one oval.

1	2	3	4	5	
Nimble	<input type="radio"/>	<input type="radio"/>	<input type="radio"/>	<input type="radio"/>	Stable

16. Mark only one oval.

1	2	3	4	5	
Light	<input type="radio"/>	<input type="radio"/>	<input type="radio"/>	<input type="radio"/>	Heavy

17. Seating

Mark only one oval.

1	2	3	4	5	
Sporty	<input type="radio"/>	<input type="radio"/>	<input type="radio"/>	<input type="radio"/>	Relaxed

18. Do you care about the brand of a motorcycle?

Mark only one oval.

Yes

No

19. Which motorcycle would you prefer to own under 250 cc ?

Mark only one oval.

- KTM Duke 200
- Benelli TNT 25
- Kawasaki Z250
- Hyosung GT 250 N
- Bajaj Pulsar AS200
- TVS Apache 200 4V
- Yamaha MT25
- Honda CBR 250

20. Would you explain your selection?

21. What are your hobbies / interests?

3. User study outputs

1. Price range selected by users

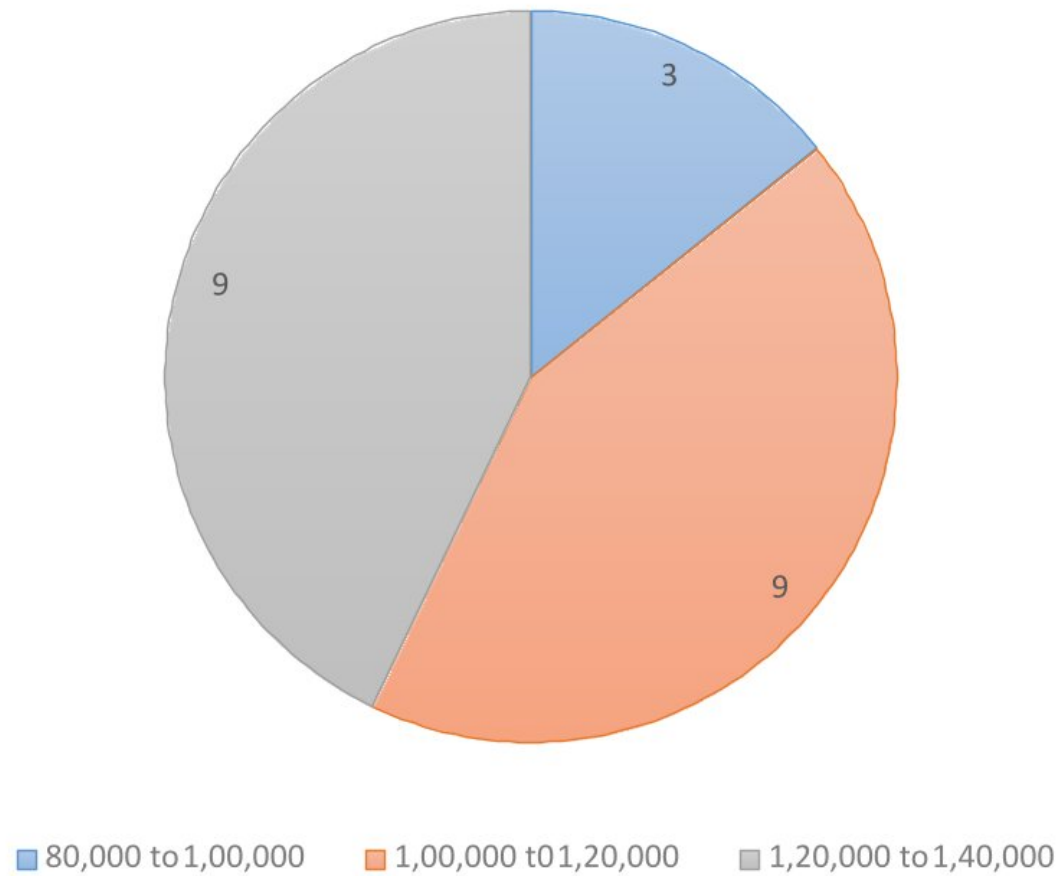

5.3.2. Looks

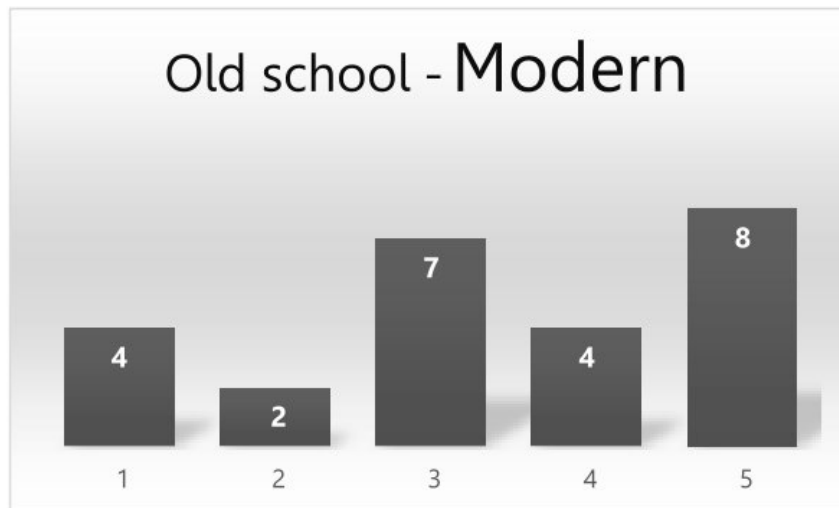
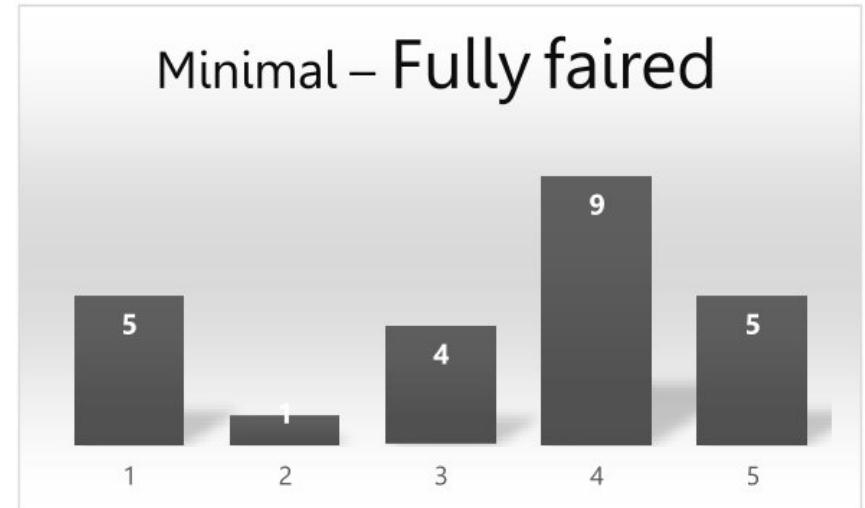
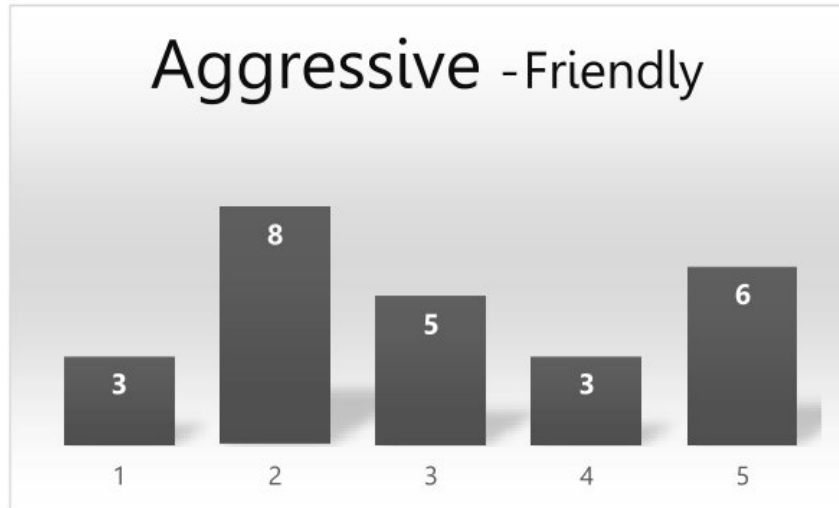

5.3.3. Performance

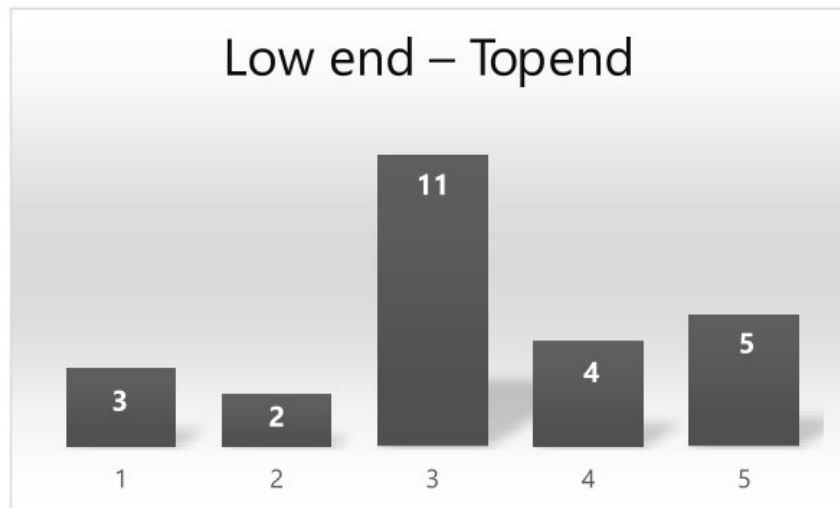
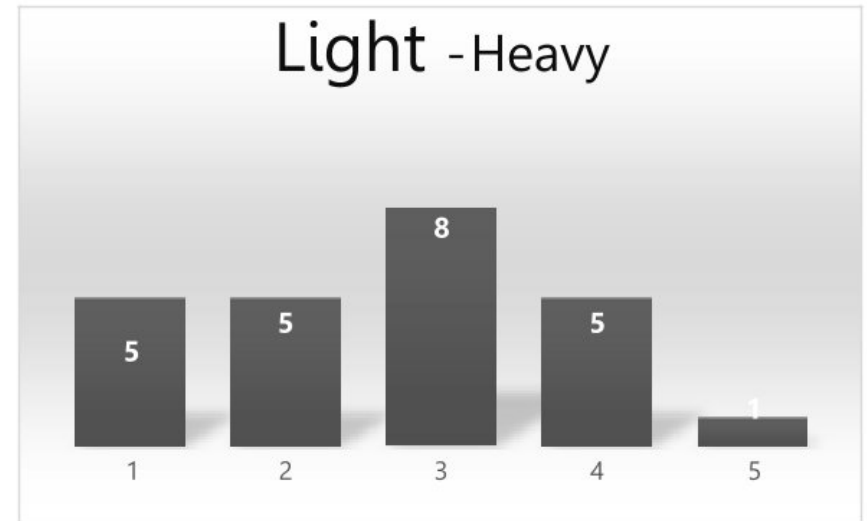
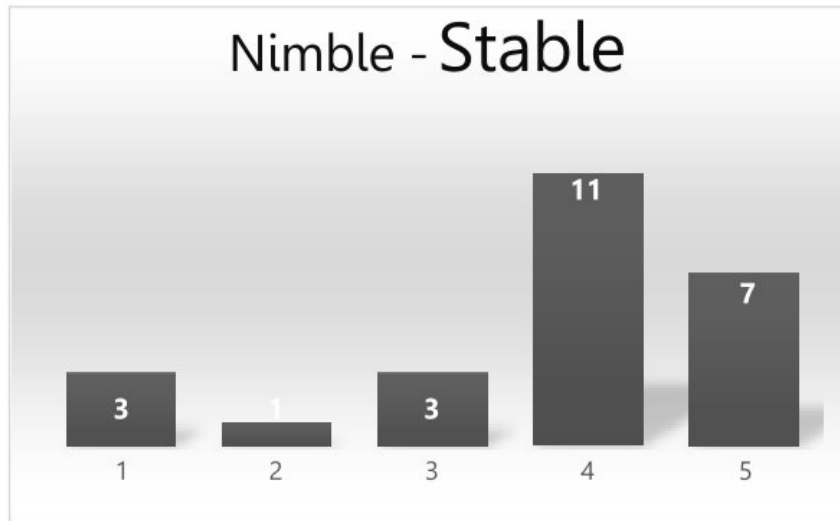

5.3.4. Seating

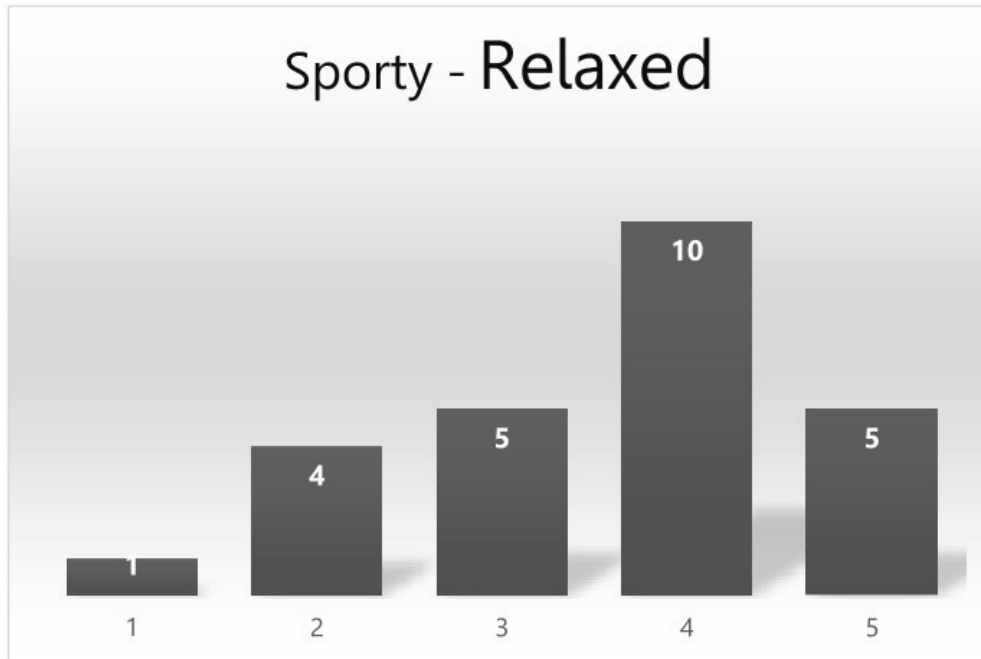

5.3.5. Favourite motorcycle (<250 cc range)

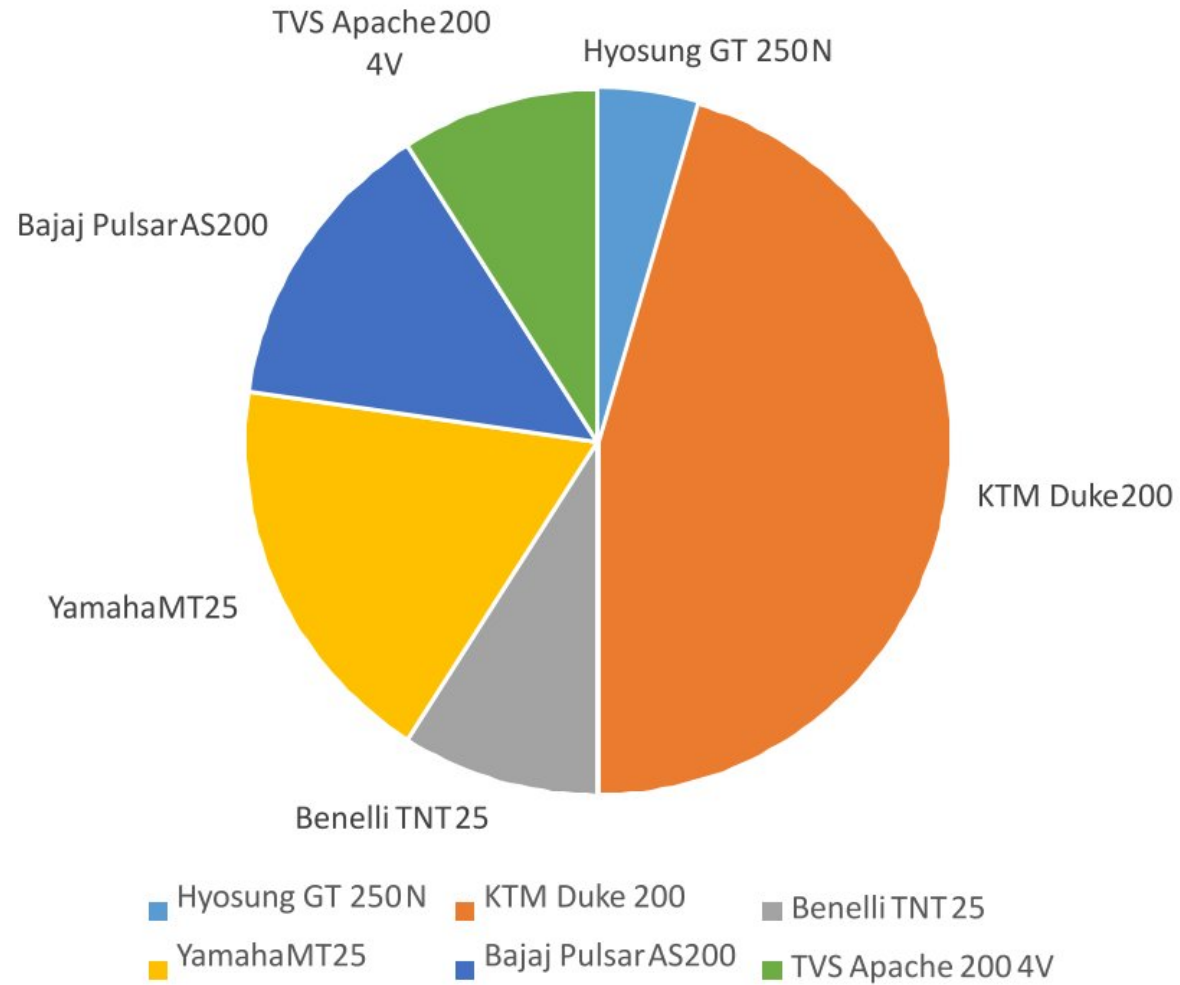

6. Choosing the engine/ benchmarking

Single cylinder 4 stroke SOHC was chosen considering RE's tradition of simplicity.

Benchmarking of similarly specced engines are done to finalize required engine output.

TVS Apache 160
150cc, SOHC, 2V,
aircooled
15.2 bhp@ 8500rpm
13.1 nm@ 4000rpm
5 spd gearbox
Rs 72,000
50 kmpl

TVS Apache 180
180cc, SOHC, 2V,
aircooled
17.3 bhp@ 8500rpm
15.5 nm@ 6500rpm
5 spd gearbox
Rs 76,544
47 kmpl

TVS Apache 200
200cc, SOHC, 4V,
oil cooled
20.2 bhp@ 8500rpm
18.1 nm@ 7000rpm
5 spd gearbox
Rs 80,000 – 1lk
na kmpl

250cc, SOHC,
oil cooled
4 valve

? bhp@ ? rpm
? nm@ ? rpm
5 spd gearbox
Rs ?
? kmpl

Expected output from the engine

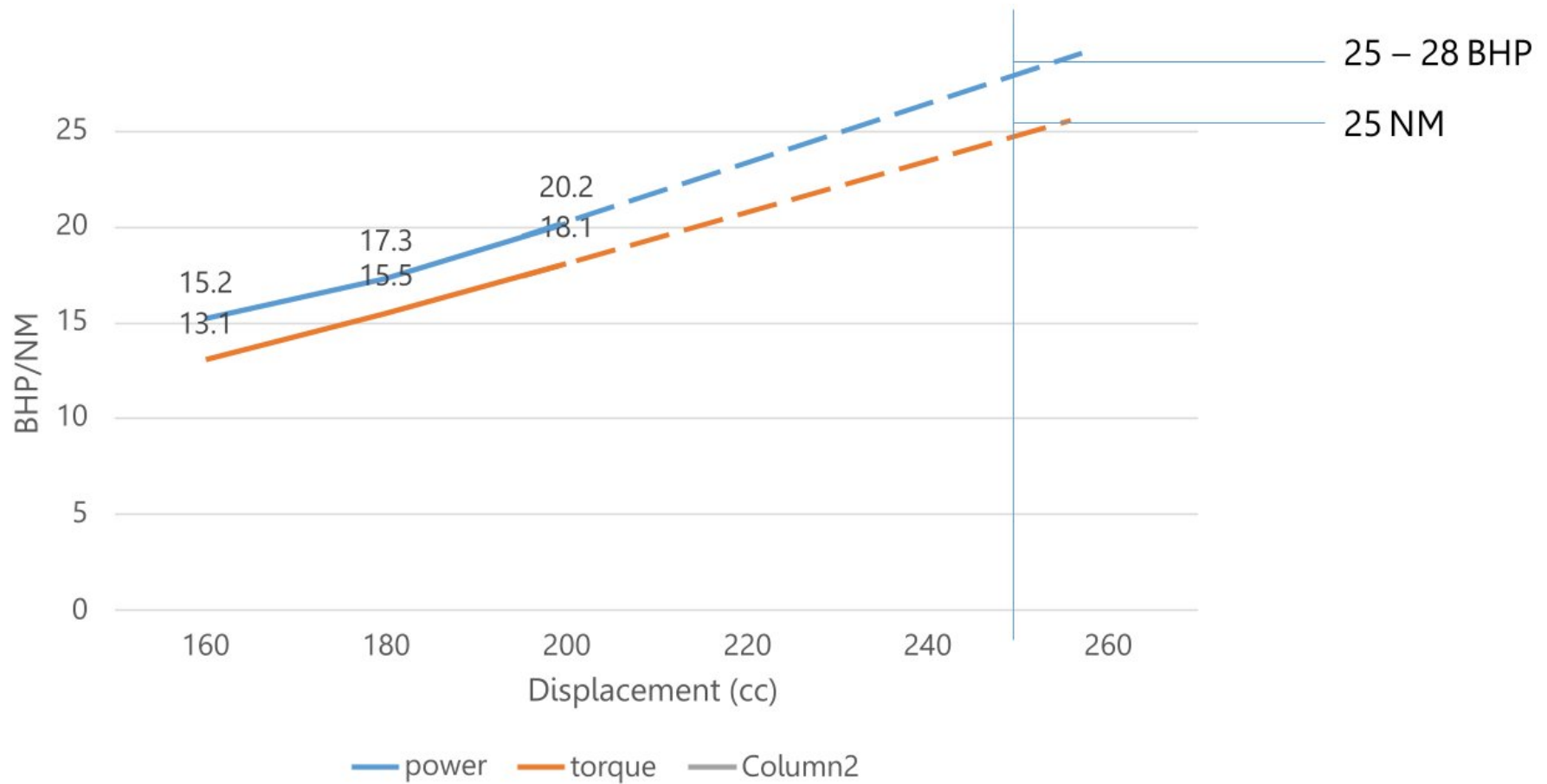

7. The concept

250 -300 cc Roadster

Price : Rs 1,00,000 to 1,20,000

Engine : 4stroke, SOHC, 4V, Oilcooled.

25-28 bhp@7500 – 8500 rpm, 22-25 nm@ 7000rpm.

Motorcycle : Lighter, smaller and nimbler than other RE's.

Moderately sporty riding position

Bring classic design cues to the crowded modern bike segment.

Should represent what RE stands for (Oneness, timelessness, simplicity and purity)

Should have a love it or hate it design. (should polarize the opinions.)

8. Persona

PERSONA
Age : 27
Independent
Own business
First premium -
motorcycle

Seeks performance

**Waiting for that
adventure**

Commuting and leisure rides

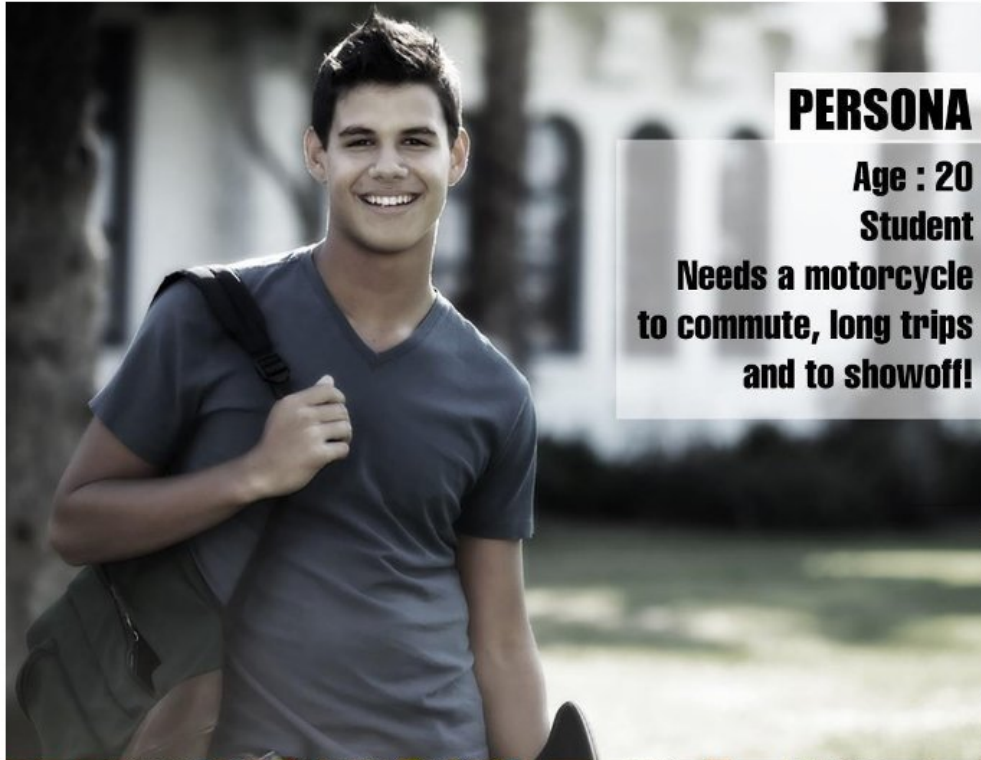

PERSONA

Age : 20
Student
Needs a motorcycle
to commute, long trips
and to showoff!



Weekdays



Commuting and leisure rides



Weekend

9. Concept Generation

- This stage contains the form ideation process.
- Wheelbase, wheel size, seat height etc. were fixed. Frame design is flexible as per the form requirements.
- Ideation was done in 3 segments – Classic, neo-classic and Modern.
- Keywords : **Compact, Powerful, Tightly packed, Light, Premium**
- One concept from each of the segments are to be finalized so that further detailing can be done.

9.1 Moodboard



9.2 Inspiration Board



Light



9.3 The Classic

In this segment, effort was put into getting right proportions and volumes of a classic motorcycle, and at the same time making it look distinctively Royal Enfield.

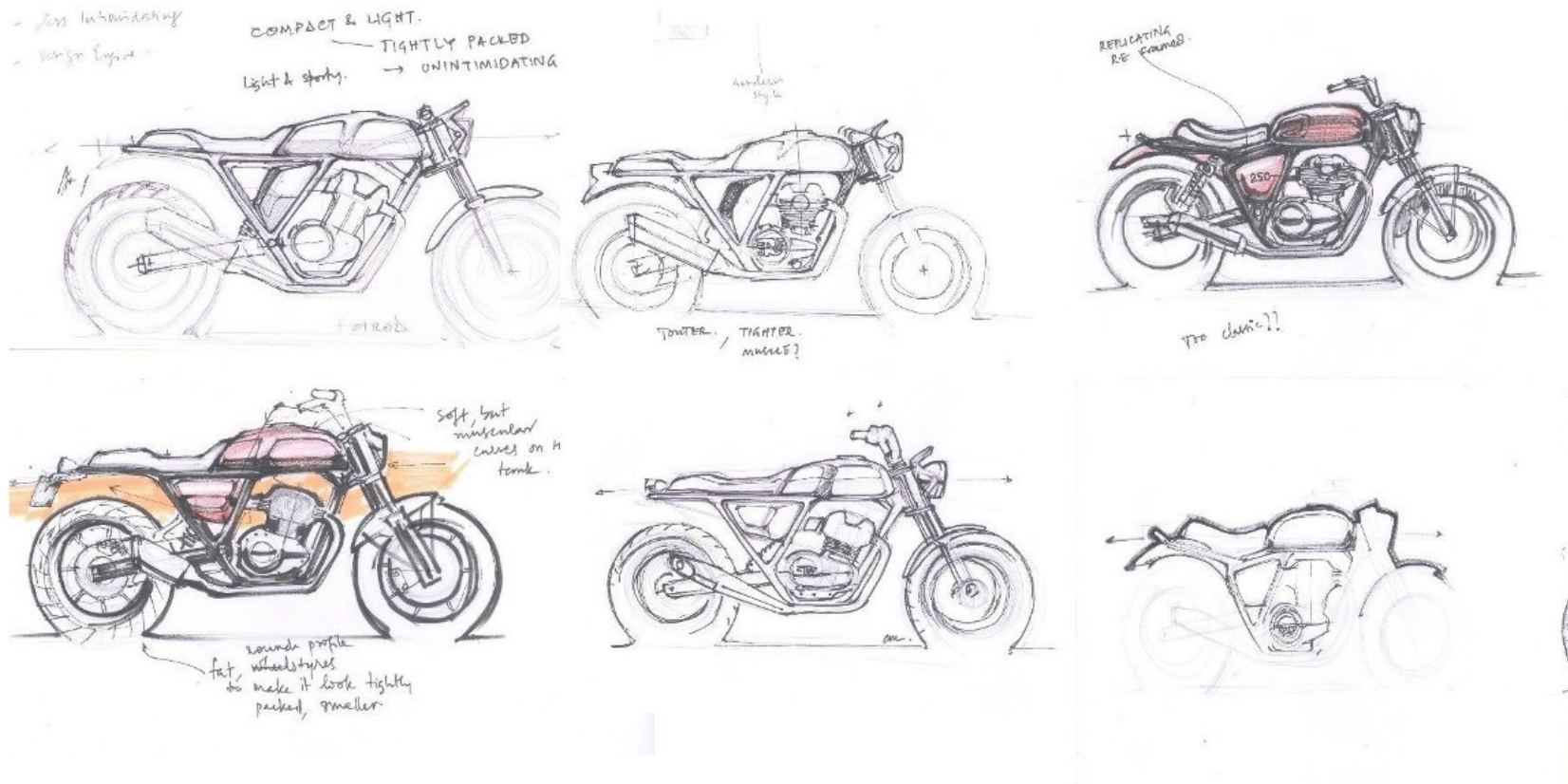

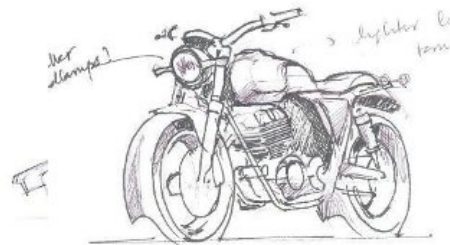

9.4 The Neo-Classic

In this segment, explorations on various proportions and frame types were done to provide a classic feel on a modern motorcycle architecture.



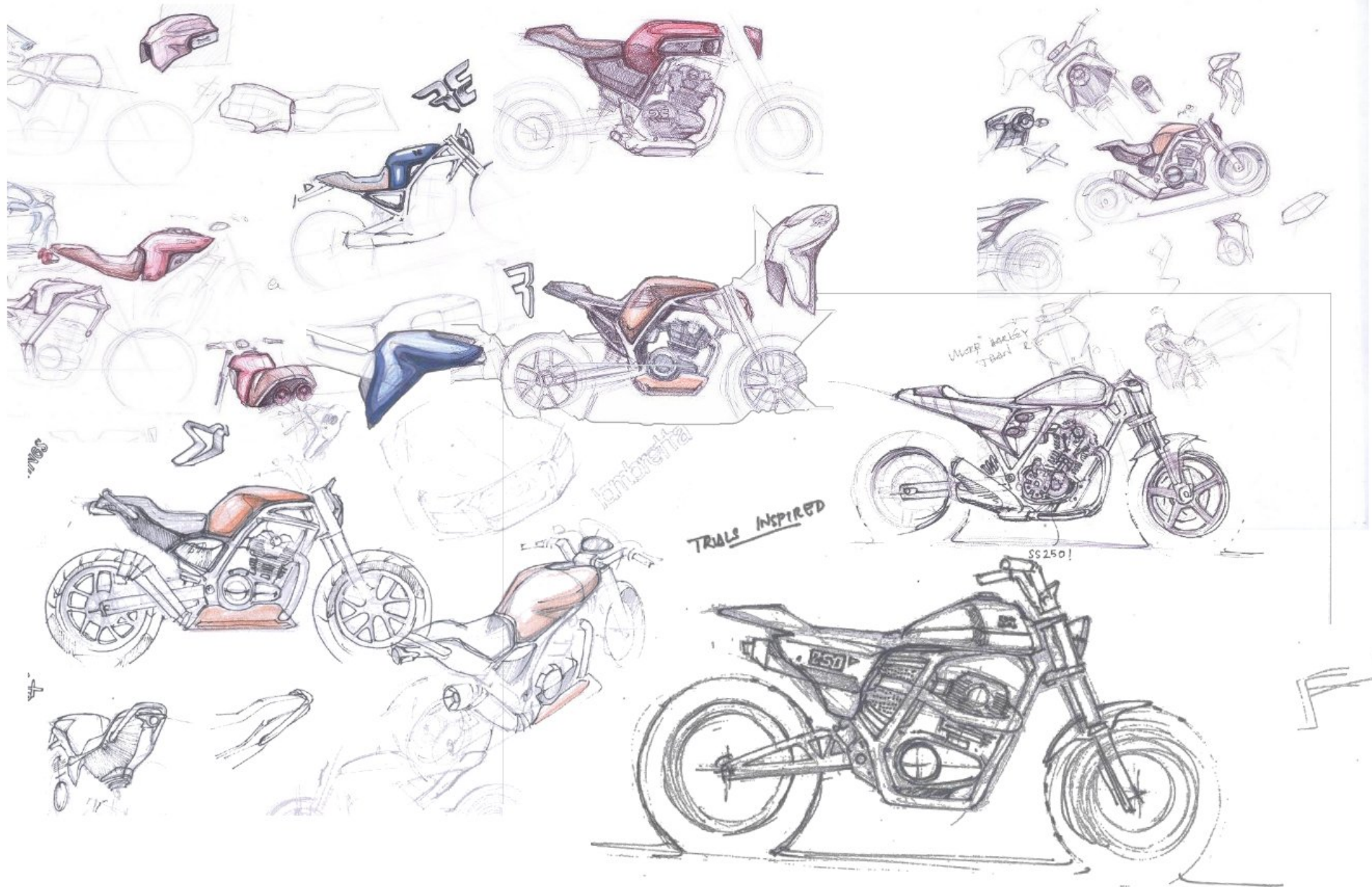

Lambretta

TRAILS INSPIRED

More Harley
Trail 250

SS250!

MAKE IT LESS OFFROADY.

$$(12 \times 25) 10 + \frac{(100 \times 0.7)}{2}$$

425
170/4
100/2
100/2
100/2

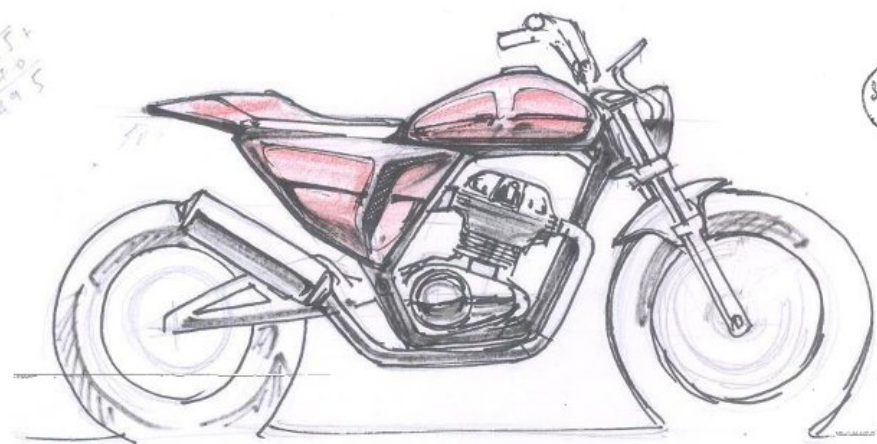

RETRO AP-1

SWEDISH
FLAG

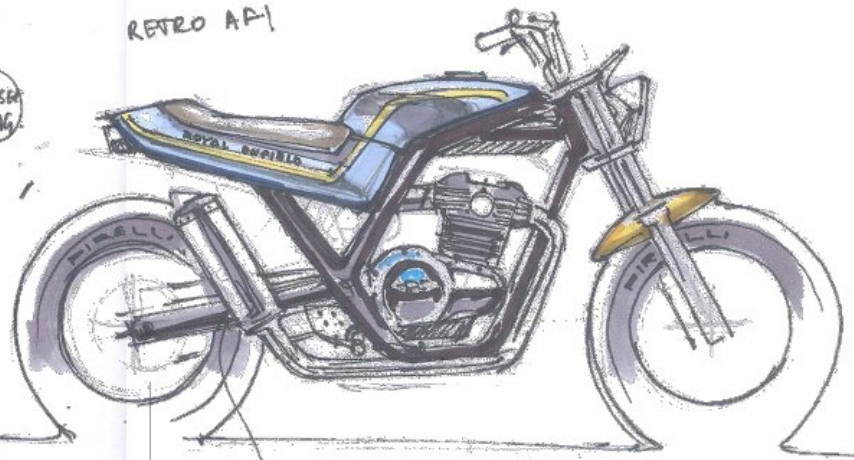

longer
handlebars.

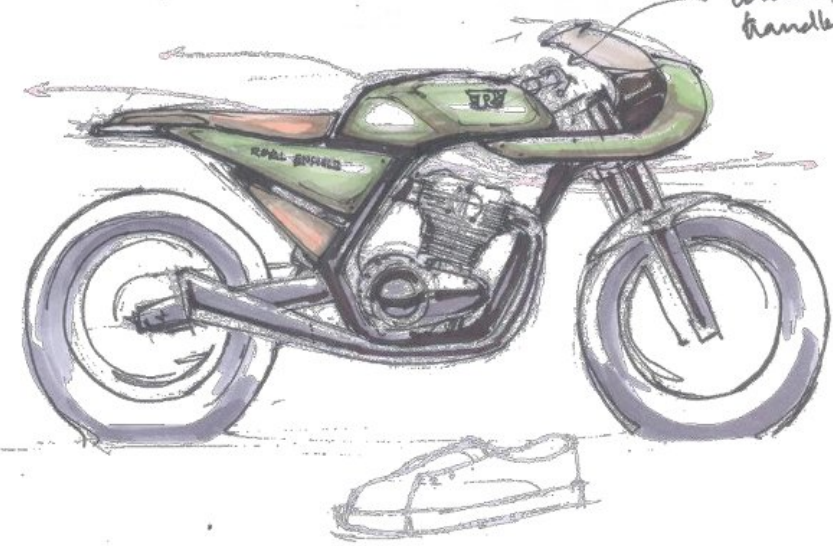

UPSWEEP
EXHAUST.

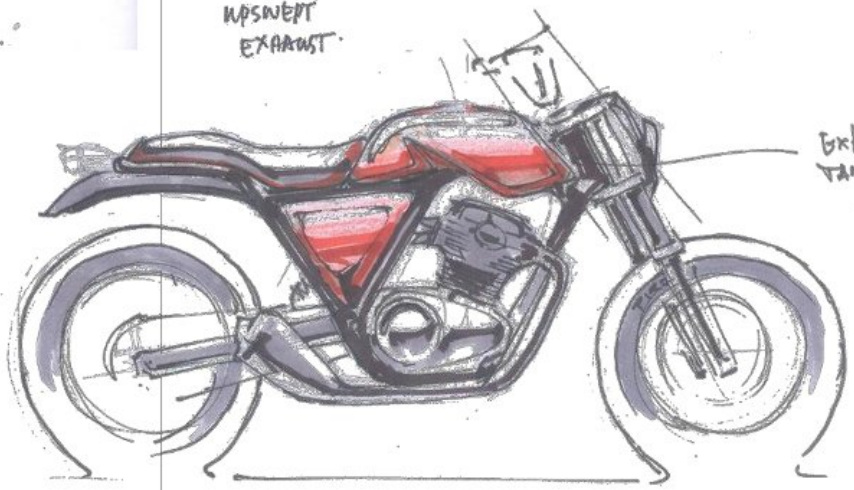

EXCLUDED
TANK
FLAPS.

9.5 The Modern

In this segment, explorations were done on modern motorcycle forms and proportions while adhering to RE,s philosophy..

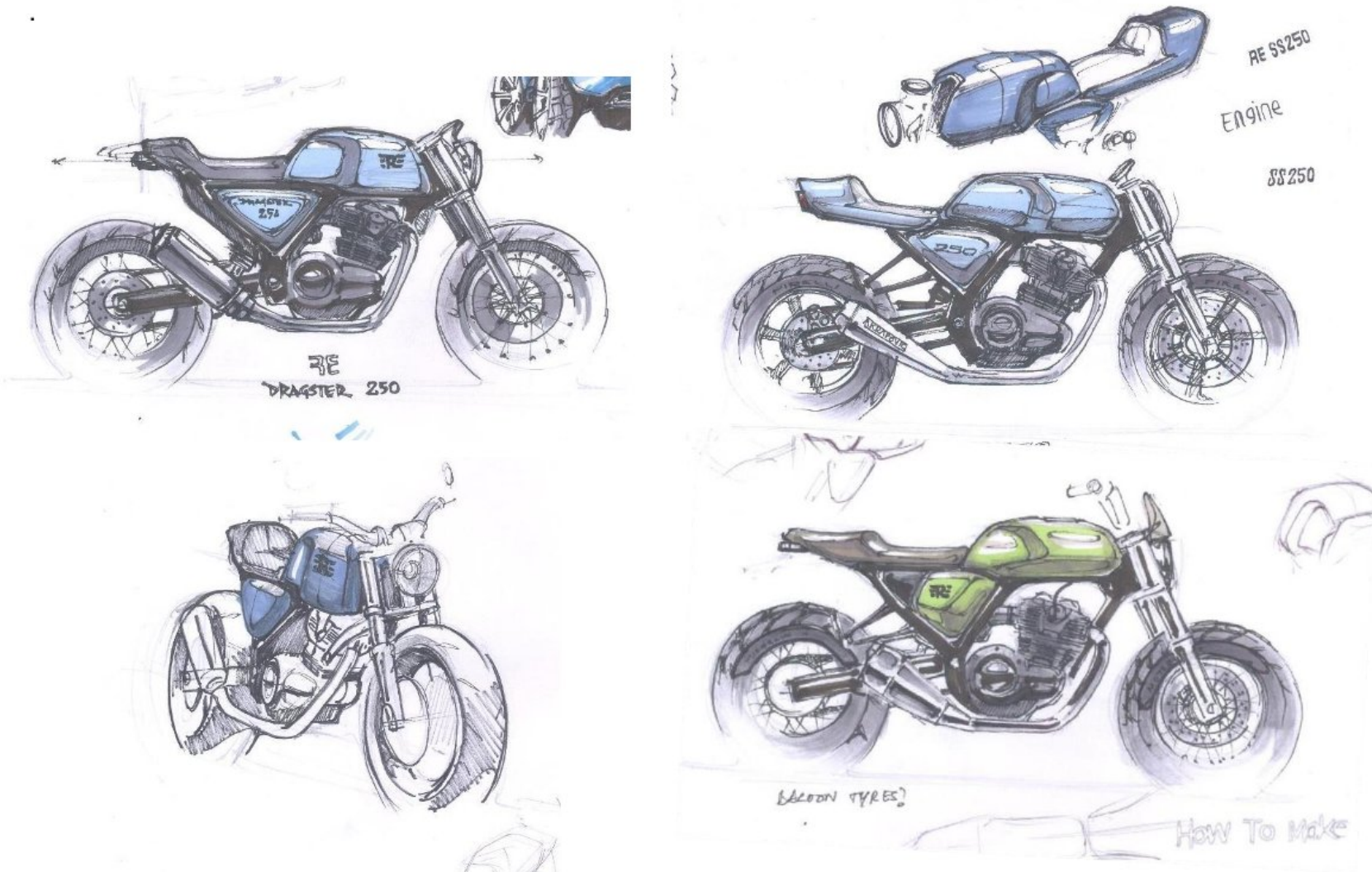

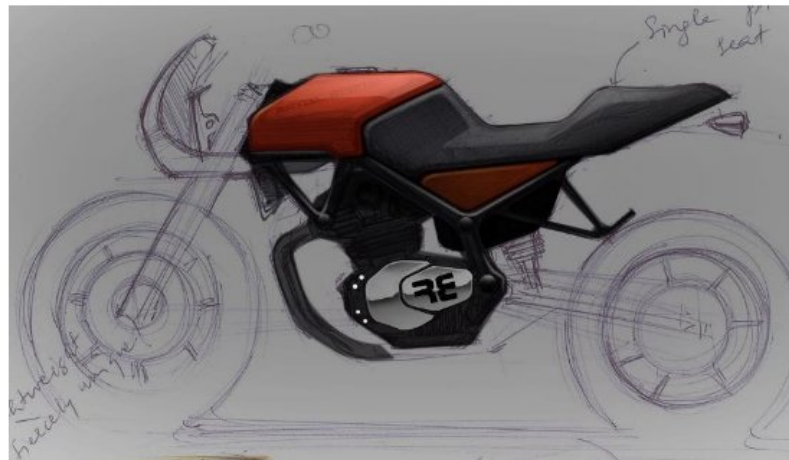

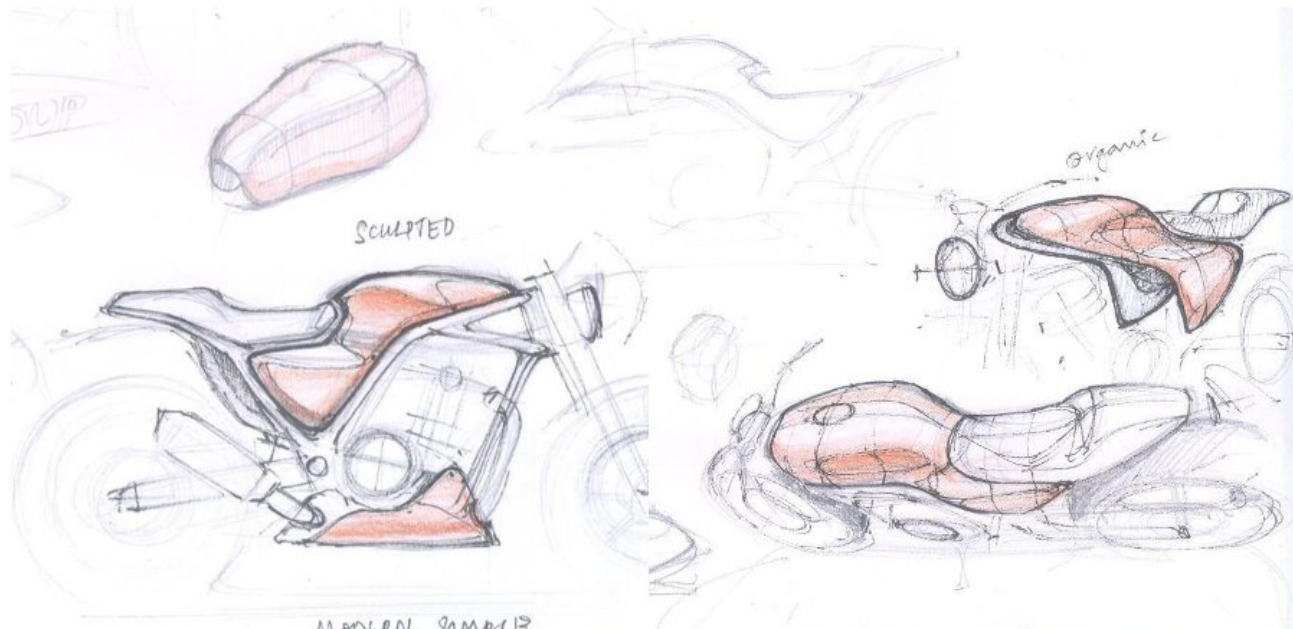

MODERN, SIMPLE,
PURE, POWERFUL, COMPACT
NEEDS EXHAUST

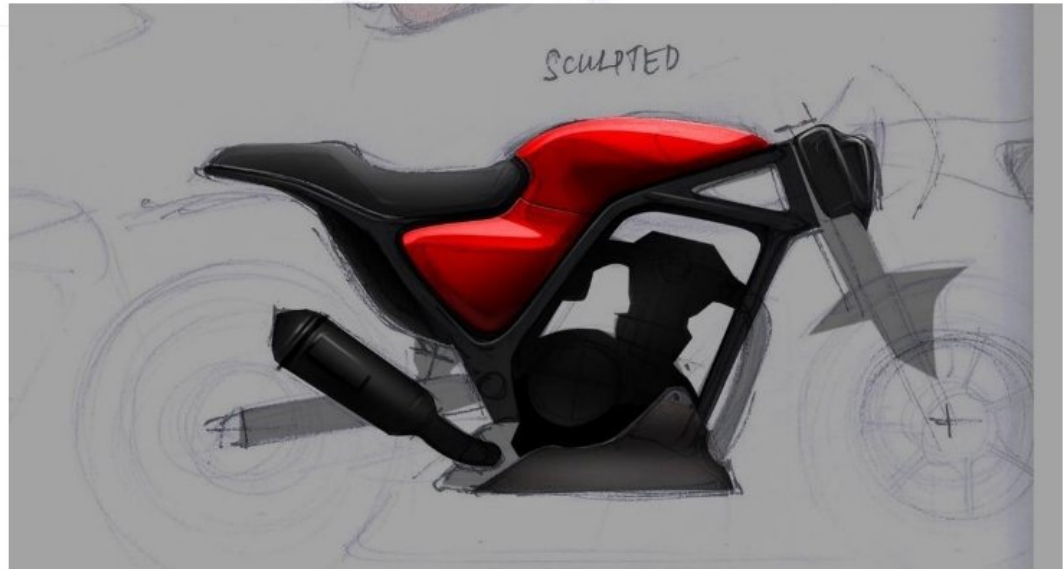



Do something different.

BOHATS

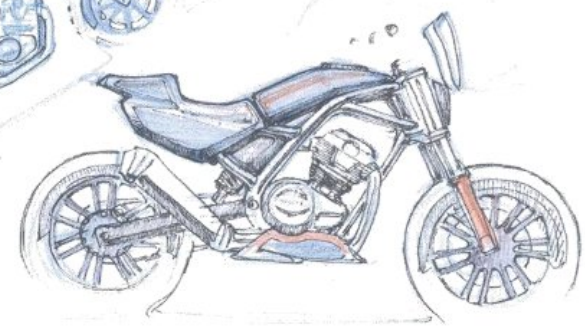
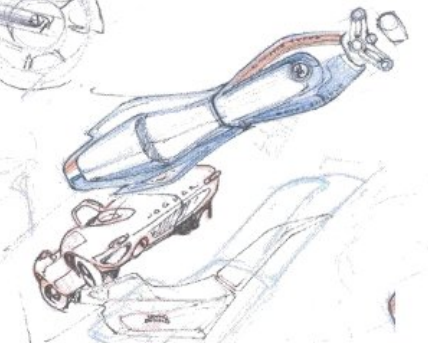
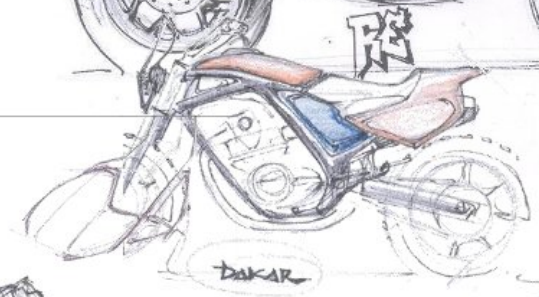



10. Concepts

One concept from each segment are selected based on the appropriateness of the direction and intent. The brand resemblance was also a concern here.

10.1 The Classic





10.2 The Neo-Classic



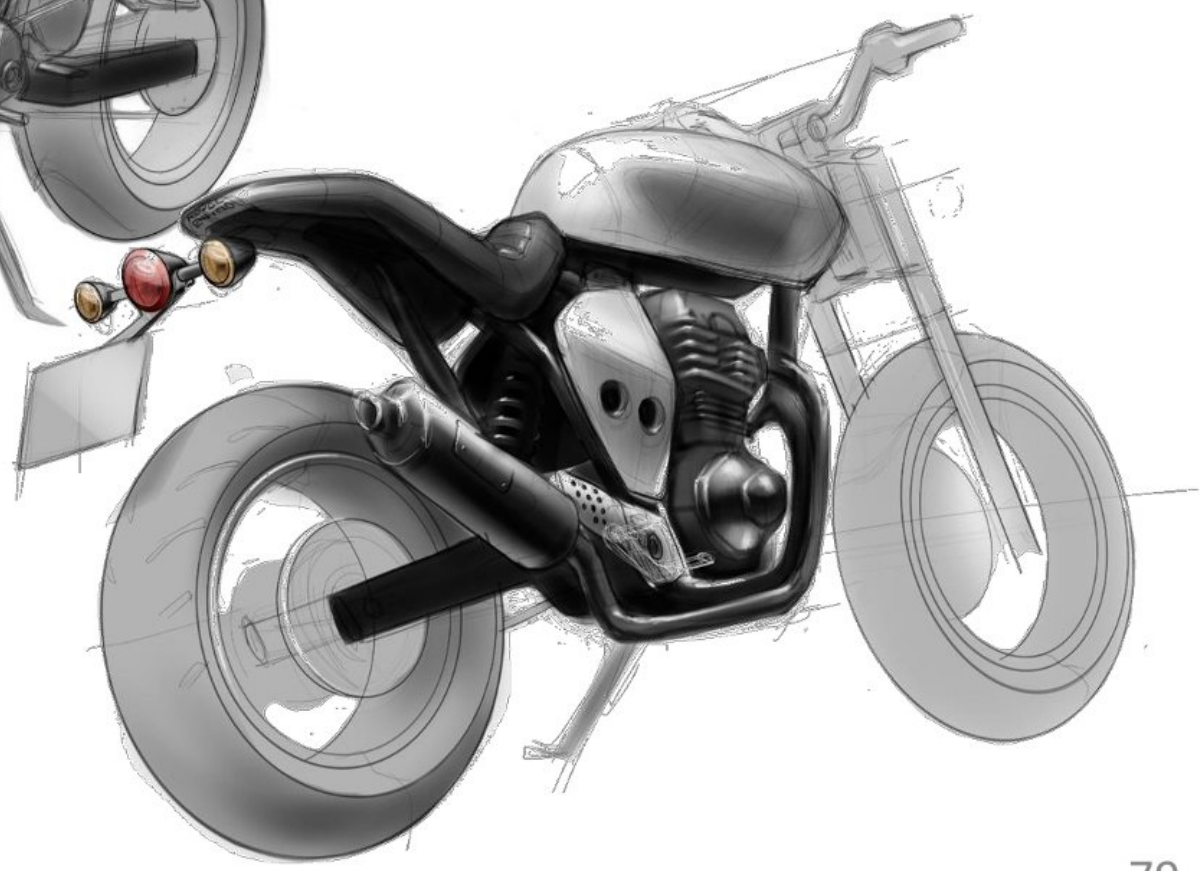

10.3 The Modern



11. Concept finalizing

Concept 1 : Even though the concept is innovative and unique, the surface treatment and volumes makes it look more like traditional Royal Enfield.

Concept 2 :

Concept 3:

12. Final renders

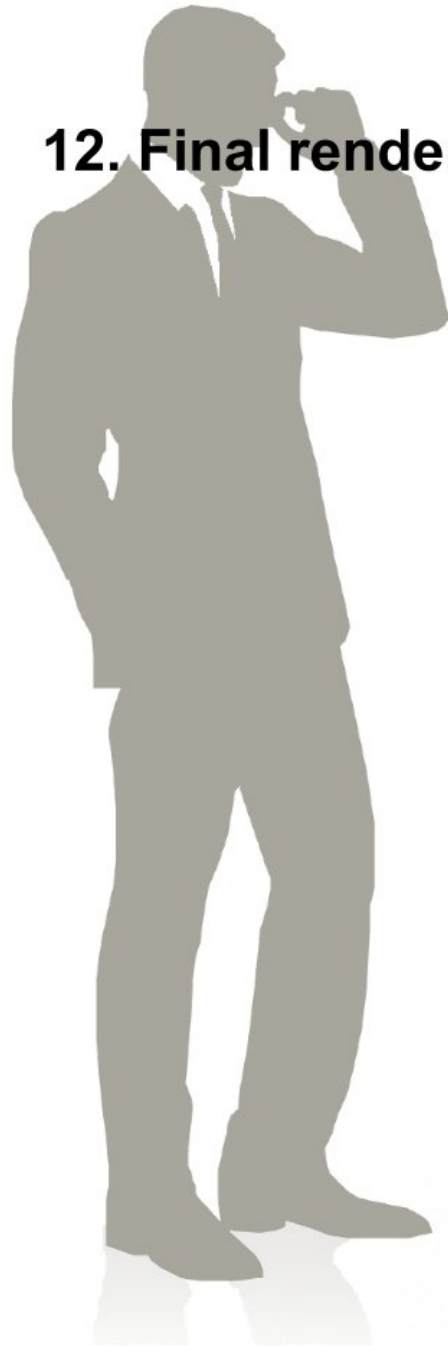





13. CAD Drawing

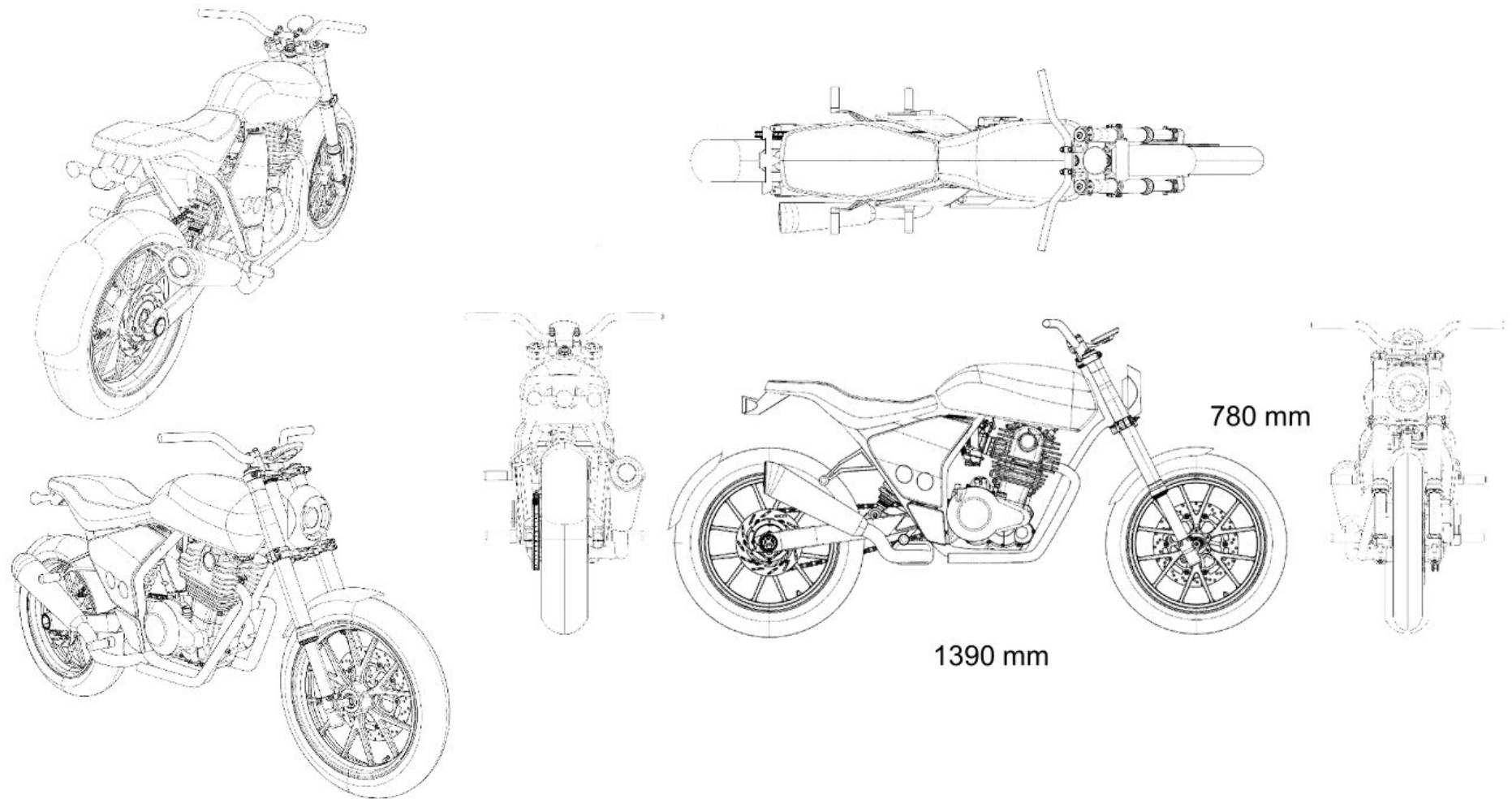

14. Ergonomics study

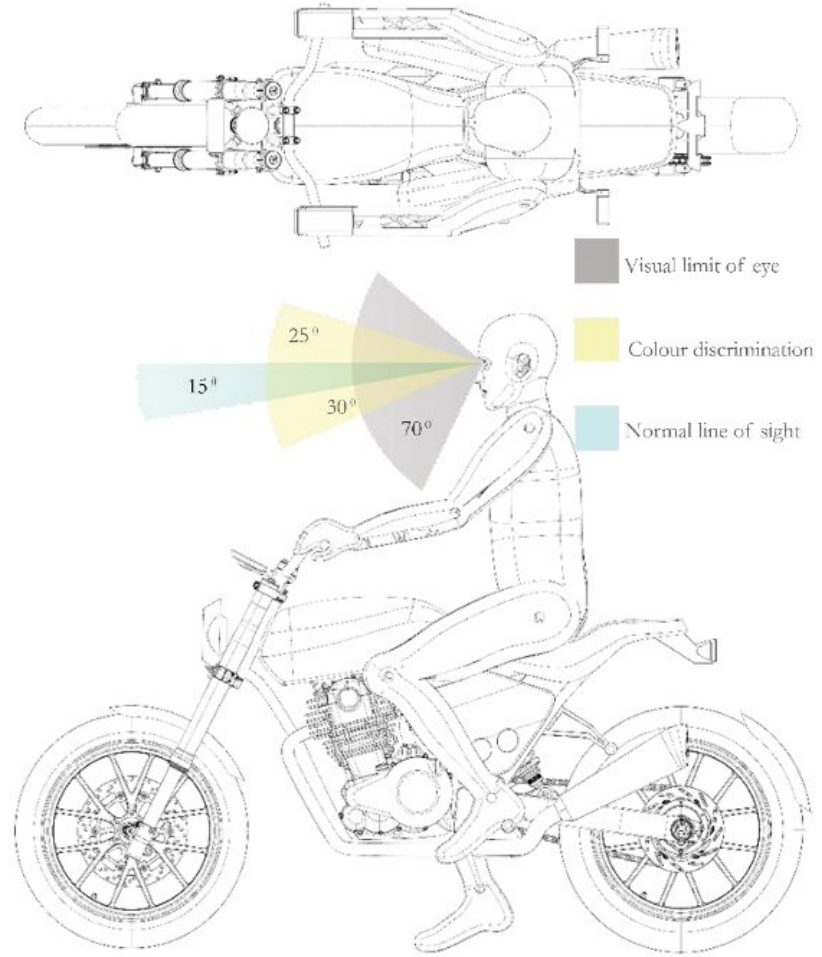

15. Scale model







16. Bibliography

Royal Enfield: The Complete Story by Mick Walker

[https://en.wikipedia.org/wiki/Royal_Enfield_\(India\)](https://en.wikipedia.org/wiki/Royal_Enfield_(India))

<http://royalenfield.com/aboutus/history/>

<http://www.autoevolution.com/moto/royal-enfield/>

<https://royalenfieldbullet.wordpress.com/about/>

<https://rideapart.com/articles/guide-to-motorcycle-categories>

https://en.wikipedia.org/wiki/Motorcycle_frame

<http://www.motorcycleexpeditions.com/history-of-royal-enfield.php>

<http://business.mapsofindia.com/automobile/two-wheelers-manufacturers/royal-enfield-motors-india.html>

<http://www.bloomsbury.com/uk/thinking-objects-contemporary-approaches-to-product-design-9782940439317/>

<http://www.fastcodesign.com/1670632/itypewriter-yes-its-an-ipad-typewriter>

<http://www.instructables.com/id/Build-Your-Own-ELECTRIC-MOTORCYCLE/>

<http://www.zeromotorcycles.com/technology/>

<http://www.goldenmotor.com/eMotorcycle/frame-emotor.htm>

<http://www.autocarindia.com/>

<http://www.topgear.com/india>

<http://www.team-bhp.com/forum/>

<http://blog.relishinteriors.com/modern-vs-contemporary-whats-the-difference/>

<http://www.houzz.com/ideabooks/1331132/list/so-your-style-is-contemporary>